

iglidur® PRT – Slewing Ring Bearing



Standard range from stock

Completely maintenance-free

Easy installation, interchangeable sliding pads

High wear resistance

For high load capacity, high stiffness

Available as stainless steel version

Wide range of accessories

iglidur® PRT

iglidur® PRT is a Slewing Ring Bearing with the proven advantages of the igus® polymer bearings. The sliding pads made from iglidur® high-performance polymers are completely free from maintenance and lubrication. All the housing components are made from anodized aluminum or stainless steel, the surfaces which mate with the iglidur® sliding pads are all hard anodized. All the fixing screws are stainless steel.

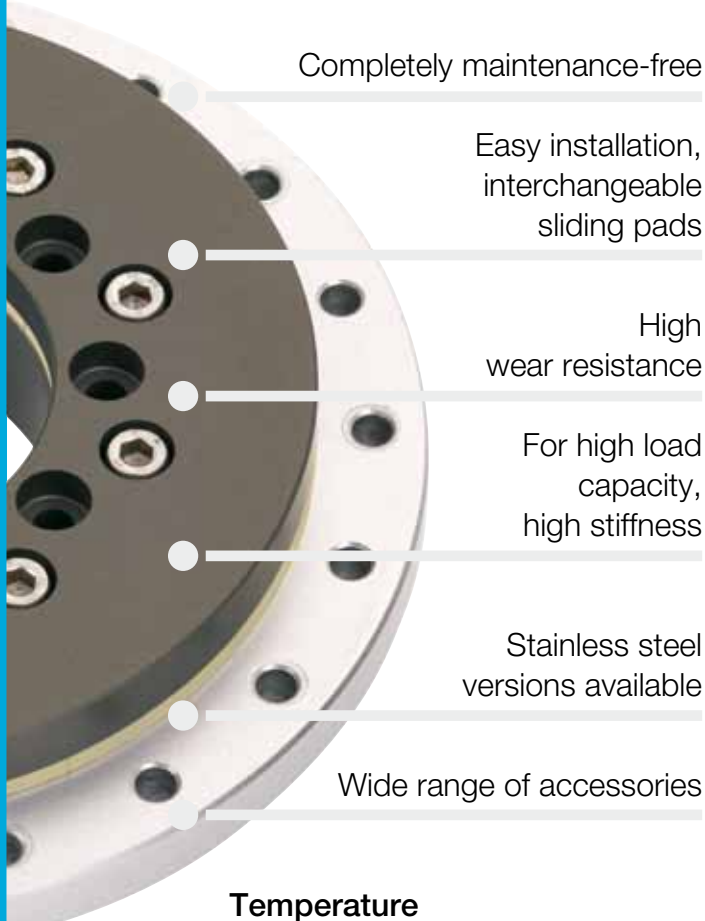

Completely maintenance-free

Easy installation,
interchangeable
sliding pads

High
wear resistance

For high load
capacity,
high stiffness

Stainless steel
versions available

Wide range of accessories

Temperature
dependant of type

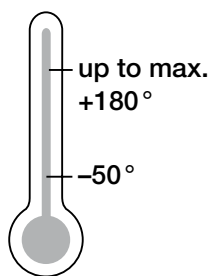

When to use it?

- When a ready-to-install fit solution is needed
- As a robust and corrosion resistant bearing unit for high loads
- For high tilting moments
- For use with different surrounding media
- When a lubrication and maintenance free Slewing Ring Bearing is needed
- For slow to medium speed



When not to use it?

- For fast rotations
- With temperatures over +180°C
- When there is not enough driving torque at high loads
- When highest precision is needed

Product range

3 types
42 dimensions
Ø 20–300 mm

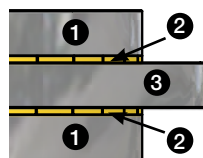

- ❶ **Type 01:**
Aluminum, hard anodized,
or Stainless steel V4A
- Type 02:**
iglidur® J4 or A180
- ❷ **Type 01:**
iglidur® J or H1
- ❸ **Type 01 and 02:**
Aluminum, anodized,
or Stainless steel V4A



iglidur® PRT | Application Examples



Typical sectors of industry and application areas

- Conveyors ● Automation
- Assembly stations ● Theatre/Stage and lighting technology ● Renewable energy etc.

Improve technology and reduce costs – 310 exciting examples for iglidur® plain bearings online

► www.igus.co.uk/iglidur-applications



Handling and conveyance system for semiconductor transport/box.



► www.igus.co.uk/movinghead



► www.igus.co.uk/welding-plant

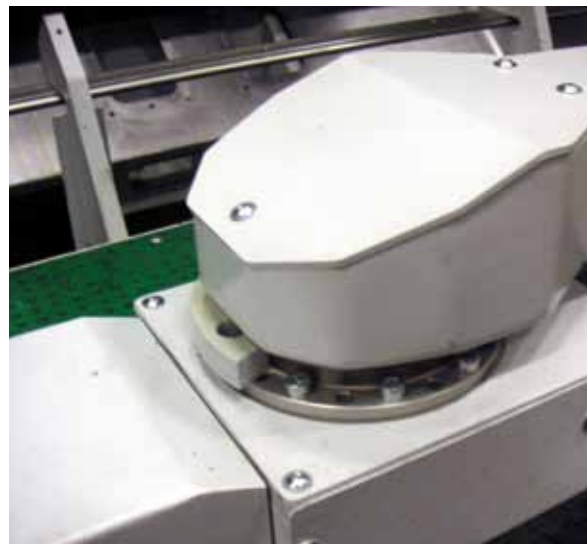

► www.igus.co.uk/cnc-machining

Slewing ring bearing

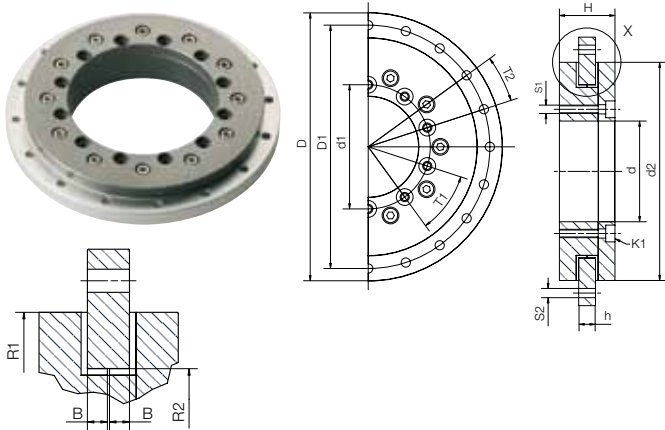

Order key

PRT-01-30-ES-H1



blank = iglidur® J
Sliding pads from iglidur® H1
Blank: Aluminium
ES: Stainless steel V4A
Inner-Ø
Type
Slewing Ring

Special properties

- Slewing ring with high stiffness
- Easy to fit
- High wear resistance
- Maintenance-free sliding pads made of iglidur® J ► [page 89](#)
- Available in aluminium or stainless steel V4A



Available in stainless steel

Dimensions [mm]

Part Number	D*	D1	d1	d	d2	H	h	T1	T2	S1	S2	K1	R1	R2	B
					±0,2							for screw			
PRT-01-30	100	91	42.5	30	82	29	10	8 x 45°	8 x 45°	M4	4.5	DIN 7984 M4	41	29	4.5
PRT-01-60	160	145	74	60	130	33	10	10 x 36°	20 x 18°	M5	5.5	DIN 912 M5	65	51.5	4.5
PRT-01-100	185	170	112	100	160	34	12	12 x 30°	16 x 22.5°	M5	5.5	DIN 912 M5	80	69	5.5
PRT-01-150	250	235	165	150	220	35	12	12 x 30°	16 x 22.5°	M5	5.5	DIN 912 M5	110	96.5	5.5
PRT-01-200	300	285	215	200	274	38	15	12 x 30°	16 x 22.5°	M6	7.0	DIN 912 M6	137	124	7.0
PRT-01-300	450	430	320	300	410	42	15	12 x 30°	16 x 22.5°	M8	9.0	DIN 7984 M8	205	186.6	7.0

* Tolerance according to DIN ISO 2768 mK

High temperature slewing ring bearing



Special properties

- Suitable up to +180°C, high chemical resistance
- For all 5 standard dimensions of style 01
- Body in aluminium or stainless steel,
- Sliding pads in iglidur® H1 ► [page 337](#)

Dimensions [mm]

Part Number	D*	D1	d1	d	d2	H	h	T1	T2	S1	S2	K1	R1	R2	B
					±0,2							for screw			
PRT-01-30-H1	100	91	42.5	30	82	29	10	8 x 45°	8 x 45°	M4	4.5	DIN 7984 M4	41	29	4.5
PRT-01-60-H1	160	145	74	60	130	33	10	10 x 36°	20 x 18°	M5	5.5	DIN 912 M5	65	51.5	4.5
PRT-01-100-H1	185	170	112	100	160	34	12	12 x 30°	16 x 22.5°	M5	5.5	DIN 912 M5	80	69	5.5
PRT-01-150-H1	250	235	165	150	220	35	12	12 x 30°	16 x 22.5°	M5	5.5	DIN 912 M5	110	96.5	5.5
PRT-01-200-H1	300	285	215	200	274	38	15	12 x 30°	16 x 22.5°	M6	7.0	DIN 912 M6	137	124	7.0
PRT-01-300-H1	450	430	320	300	410	42	15	12 x 30°	16 x 22.5°	M8	9.0	DIN 7984 M8	205	186.6	7.0

* Tolerance according to DIN ISO 2768 mK



delivery available from stock



prices price list online
www.igus.co.uk/en/prt



order part number
example PRT-01-30

iglidur® PRT | Technical Data Type 01

Properties	Unit	PRT-01-30	PRT-01-60	PRT-01-100	PRT-01-150	PRT-01-200	PRT-01-300
Weight	kg	0.4	1.1	1.3	2.2	3.2	7.6
Max. axial load, static	N	27,000	50,000	55,000	80,000	100,000	150,000
Max. axial load, dynamic	N	7,000	15,000	16,000	25,000	30,000	90,000
Max. radial load, static	N	5,000	10,000	16,000	25,000	35,000	45,000
Max. radial load, dynamic	N	1,500	3,000	5,000	8,000	10,000	27,000
Max. rotat. speed dry running	1/min	250	200	150	100	80	50
Rigidity, axial	N/μm	100	300	400	450	500	500
Rigidity, radial	N/μm	50	65	65	65	65	65
Max. perm. tilting moment	Nm	200	800	1,500	2,000	3,800	5,000

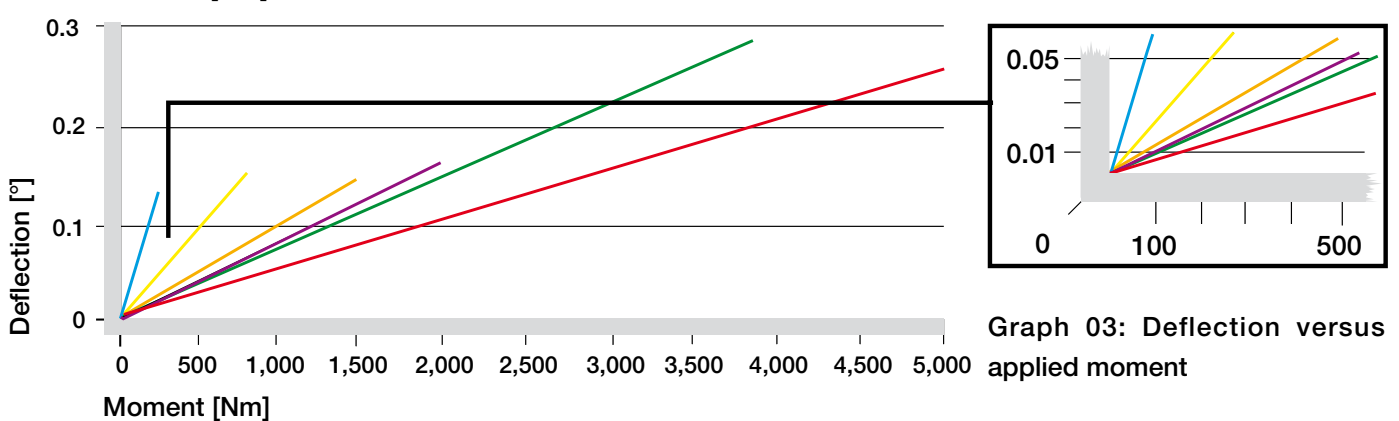
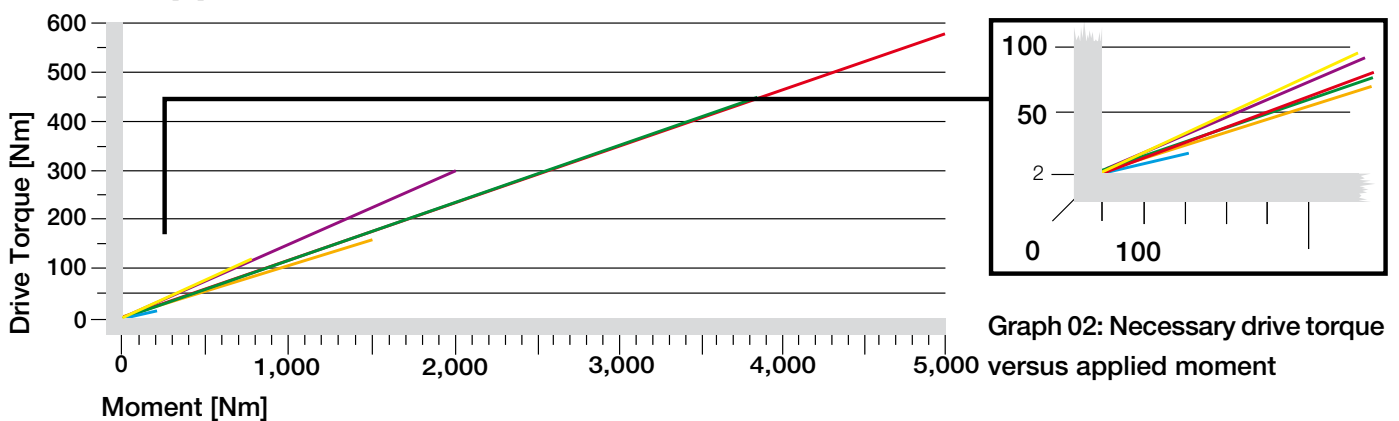
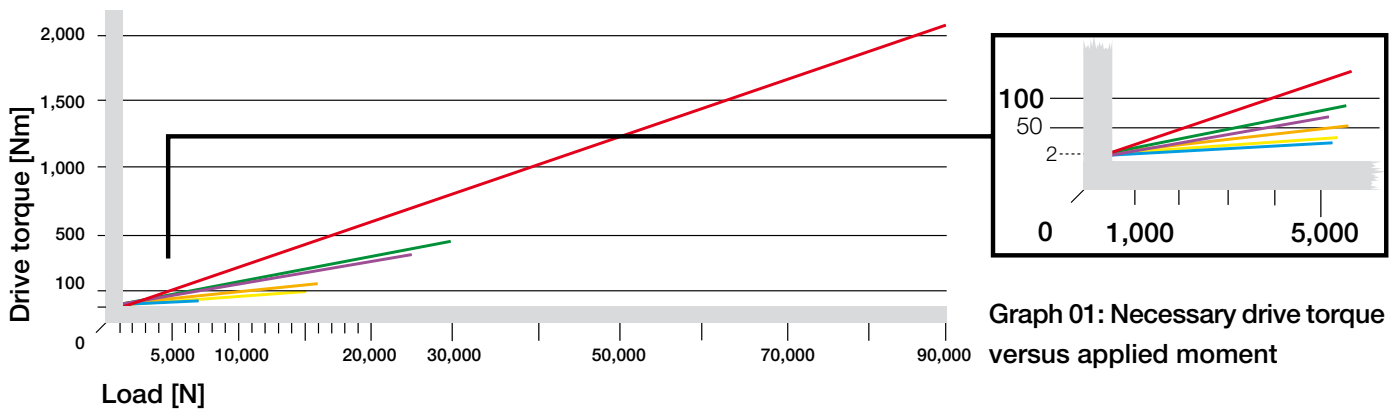

- PRT-01-30
M4, min.
8 screws
- PRT-01-60
M5, min.
10 screws
- PRT-01-100
M5, min.
12 screws
- PRT-01-150
M5, min.
12 screws
- PRT-01-200
M6, min.
12 screws
- PRT-01-300
M8, min.
12 screws

All load values assume the PRT is assembled with socket head screws (strength class 8.8) on the outside pitch circle diameter. For the assembly of the PRT the screws have to be inserted to a minimum thread depth of 2xd in every bore location in the outer ring. All data can be used for both lateral and horizontal assembly.

Slewing ring bearing with toothed outer ring

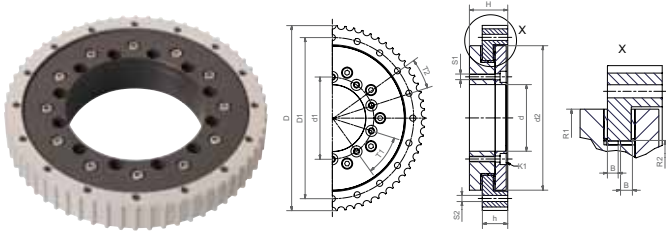

For each of the 6 sizes of the PRT-01 design version, 4 standards for toothed outer ring are available.

A classic spur gear teeth according to DIN3967 for use with a plastic gear or gear rack, and three commercially available belt profiles: T10, AT10, HTD8M. In the case of the externally toothed PRT, the inner ring is fixed and the outer ring driven.

At the same time the toothed outer ring with a special large diameter carries the gear.



Order key

PRT-01-30-TO-...



Dimensions [mm]

Part number	D1	d1	d	d2	h	T1	T2	S1	S2	K1	R1	R2	B	H
PRT-01-30-TO-...	91	42.5	30	82	21	8x45°	8x45°	M4	4,5	DIN 912 M4	41	29.0	4.5	(30.4)
PRT-01-60-TO-...	145	74.0	60	130	23	10x36°	20x18°	M5	5,5	DIN 912 M5	65	51.5	4.5	(34.5)
PRT-01-100-TO-...	170	112.0	100	160	25	12x30°	16x22,5°	M5	5,5	DIN 912 M5	80	69.0	5.5	(36.0)
PRT-01-150-TO-...	235	165.0	150	220	25	12x30°	16x22,5°	M5	5,5	DIN 912 M5	110	96.5	5.5	(37.5)
PRT-01-200-TO-...	285	215.0	200	274	30	12x30°	16x22,5°	M6	7,0	DIN 912 M6	137	124.0	7.0	(41.5)
PRT-01-300-TO-...	430	320.0	300	410	30	12x30°	16x22,5°	M8	9,0	DIN 912 M8	205	186.5	8.5	(46.5)

Spur gearing DIN3967

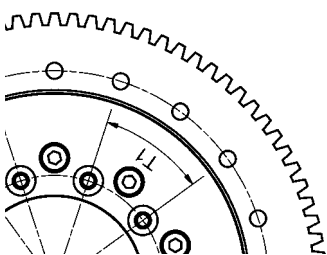

Part number	m	z	D
...-ST	2	54	(112)
...-ST	2	90	(184)
...-ST	2	96	(196)
...-ST	2	126	(256)
...-ST	2	152	(308)
...-ST	3	152	(462)

Toothed belt profile AT10

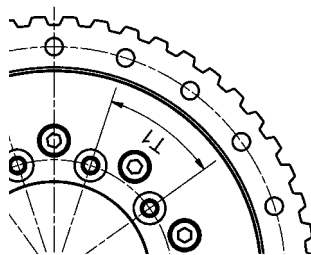

Part number	z	D
...-AT10	34	(106.4)
...-AT10	52	(163.8)
...-AT10	60	(189.2)
...-AT10	80	(252.9)
...-AT10	96	(303.9)

Toothed belt profile T10

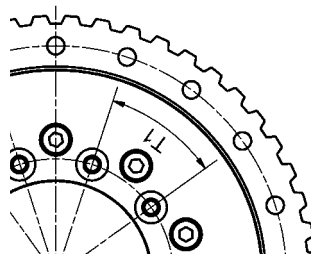

Part number	z	D
...-T10	34	(106.4)
...-T10	52	(163.8)
...-T10	60	(189.2)
...-T10	80	(252.9)
...-T10	96	(303.9)
...-T10	144	(456.7)

Toothed belt profile HTD8M

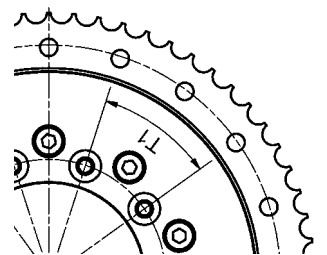

Part number	z	D
...-HTD8M	34	(105.6)
...-HTD8M	52	(166.7)
...-HTD8M	60	(189.2)
...-HTD8M	80	(253.3)
...-HTD8M	96	(304.3)
...-HTD8M	144	(457.1)



delivery available
time from stock



prices price list online
www.igus.co.uk/en/prt



order part number
example PRT-01-30-TO-...

iglidur® PRT | Product Range Type 02

Slewing ring bearing

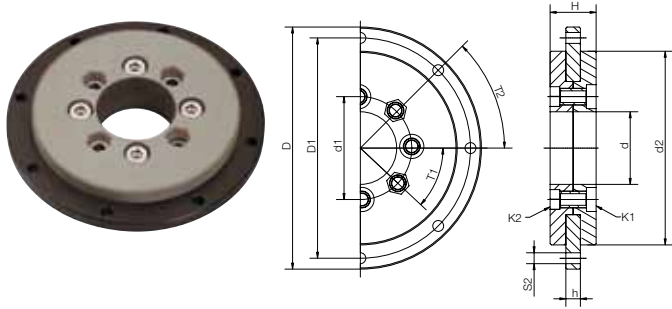

Order key

PRT-02-20-AL



AL: Aluminium
ES: Stainless steel V4A
Inner-Ø
Type
Slewing Ring

Special properties

- Slewing ring with very low weight
- Outer ring made from hard anodized Aluminium or stainless steel (V4A)
- iglidur® J4 – head rings – sliding against the outer ring without lubrication
- Low cost



Outer ring available in stainless steel as an option. Headrings made from iglidur® J4

Dimensions [mm]

Part number	D*	D1	d1	d	d2	H	h	T1	T2	S2	K1		K2	
											for screw		for screw	
PRT-02-20-AL/ES	80	70	31	20	60	16	5	6 x 60°	6 x 60°	4,5	DIN 6912-A2 M5	DIN 439-A2 M5		
PRT-02-30-AL/ES	100	91	42,5	30	80	19	6	8 x 45°	8 x 45°	4,5	DIN 7984 M5	DIN 439-A2 M5		
PRT-02-60-AL	160	145	86,0	60	130	30	10	12 x 30°	20 x 18°	5,5	DIN 931 M5X25	DIN 934 M5		

Slewing ring bearing, FDA compliant



Special properties

- For use in the food technology with headrings made from FDA-conform material iglidur® A180
- The stainless steel outer ring and the material iglidur® A180 ► **page 371** are suitable for the direct contact with food, pharmaceuticals and humidity.
- Low profile and low weight
- Ready to fit

Dimensions [mm]

Part Number	D*	D1	d1	d	d2	H	h	T1	T2	S2	K1		K2	
											for screw		for screw	
PRT-02-30-ES-A180	100	91	42,5	30	80	19	6	8 x 45	8 x 45	4,5	DIN 7984 M5	DIN 439-A2 M5		

Properties	Unit	PRT-02-20	PRT-02-30	PRT-02-60
Weight	kg	0,1	0,2	0,7
Max. axial load, stat.	N	13,000	25,000	45,000
Max. axial load, dyn.	N	4,000	7,000	12,000
Max. radial load, stat.	N	2,000	2,500	10,000
Max. radial load, dyn.	N	500	700	2,800
Max. rotat. speed dry running	1/min	250	200	120
Max. permissible tilting moment	Nm	60	100	200



delivery available
time from stock



prices price list online
www.igus.co.uk/en/prt



order part number
example PRT-02-20-AL/-ES

Slewing ring bearing in a new Low-Cost-Design

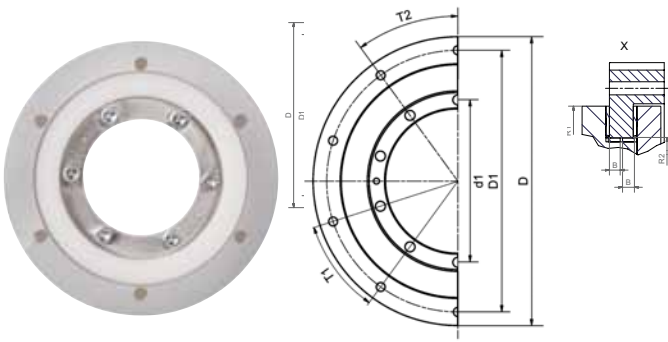

Order key

PRT-03-80

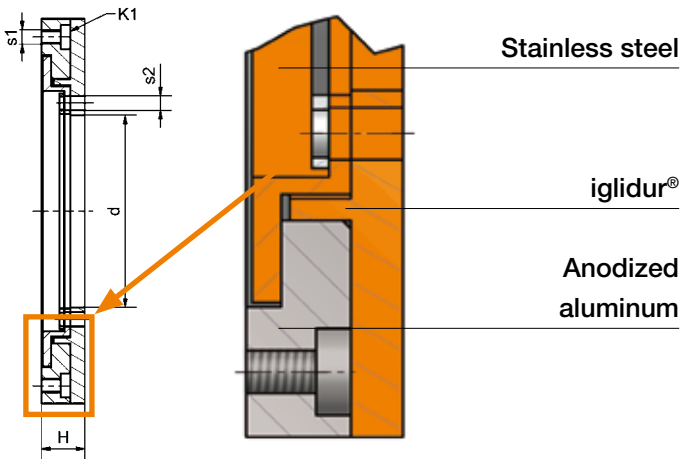
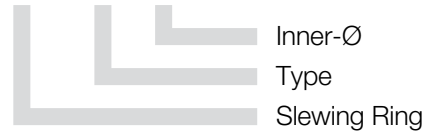

iglidur® PRT slewing ring bearings in a new economic design. Ongoing cost engineering has resulted in a new design, with a greater use of plastics.

- Maintenance- and lubrication-free
- Low priced and lightweight
- Low installation space
- Ready to fit

Properties	Unit	PRT-03-80
max. rpm	rpm	120
max. recommended static load rating axial (push direction)	N	12,000
recommended dynamic load rating axial (push direction)	N	45,000
max. recommended static load rating axial (pull direction)	N	5,000
max. recommended dynamic load rating axial (pull direction)	N	2,000
max. recommended static overturning moment	Nm	120
max. recommended static load rating radial	N	4,000
max. recommended dynamic load rating radial	N	1,000
max. temperature	°C	60

Dimensions [mm]

Part number	D	D1	d1	d	H	T1	T2	s1	s2	K1
PRT-03-80	160	145	90	80	18	10 x 36°	10 x 36°	M6	6	M5



delivery available
time from stock



prices price list online
www.igus.co.uk/en/prt



order part number
example PRT-03-80

iglidur® PRT | Product Range Accessories

Hand clamp

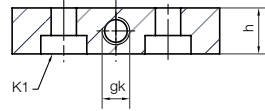
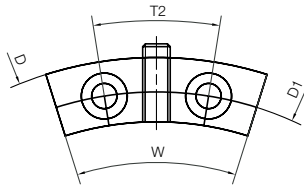

Graph 04: PRT with fitted manual clamp

- With 1 Nm screw torque, a holding torque up to 10 Nm is possible
- Easy to screw onto outer ring

Dimensions [mm]

Part number	D	D1	T2	K1	h	gk	W
PRT-HK-60	160	145	20 x 18°	DIN 7984 M5	10	M6	35°
PRT-HK-100*	205	185	16 x 22.5°	DIN 7984 M5	12	M6	40°
PRT-HK-200*	320	300	16 x 22.5°	DIN 7984 M6	15	M6	40°

* Only available with large outer rings

Slewing ring bearing with large outer ring

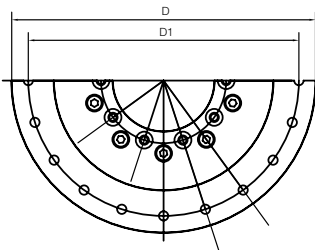

Dimensions [mm]

Part number	D	D1
PRT-01-100-M-ARG*	205	185
PRT-01-100-M-ARGG*	205	185
PRT-01-100-M-ARGS*	205	185
PRT-01-200-M-ARG*	320	300
PRT-01-200-M-ARGG*	320	300
PRT-01-200-M-ARGS*	320	300

* Ending: -G standard, -GG thread- or -GS counterbore

Other dimensions such as Standard type PRT-01 ► page 548

 **delivery time** available from stock

 **prices** price list online www.igus.co.uk/en/prt

 **order example** part number PRT-HK-60
PRT-01-100-M-ARG

Drive pin

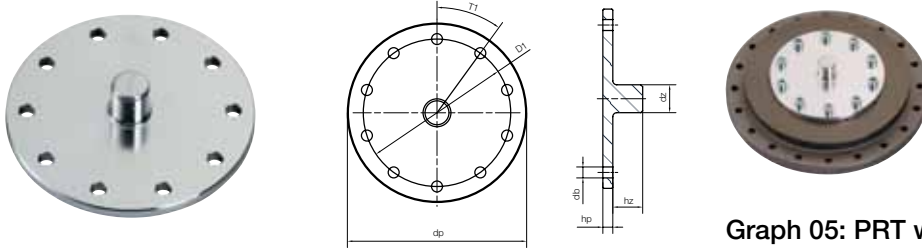

Graph 05: PRT with assembled drive pin

Dimensions [mm]

Part number	dp	hp	dz	hz	D1	T1	db
PRT-AZ-30	55	5	10	15	42.5	8 x 45°	4.5
PRT-AZ-60	90	5	14	15	74	10 x 36°	5.5

Spacing rings made from anodized aluminum

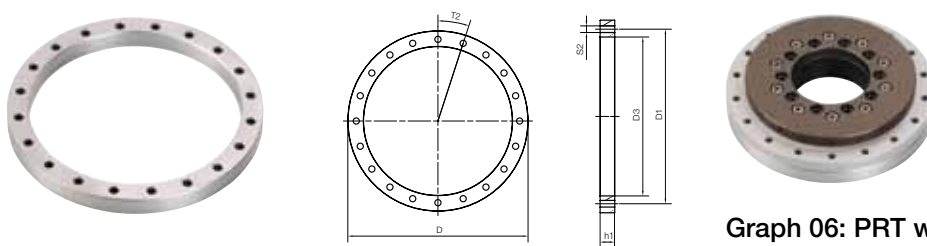

Graph 06: PRT with assembled spacing ring

Dimensions [mm]

Part number	D	D1	T2	S2	D3	h1
PRT-01-30-DR	100	91	8 x 45°	4.5	84	11
PRT-01-60-DR	160	145	20 x 18°	5.5	132	13
PRT-01-100-DR	185	170	16 x 22,5°	5.5	162	13
PRT-01-150-DR	250	235	16 x 22.5°	5.5	222	13
PRT-01-200-DR	300	285	16 x 22.5°	7.0	276	13

Spacing rings made from polymer

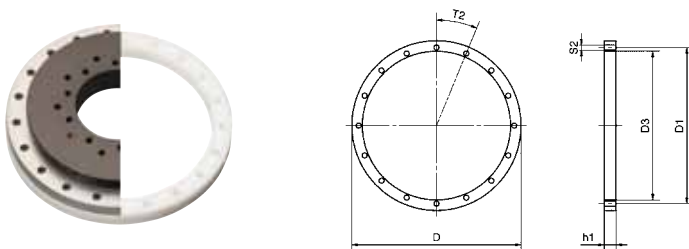

Dimensions [mm]

Part number	D	D1	T2	S2	D3	h1
PRT-01-30-DR-POM	100	91	8 x 45°	4.5	84	11
PRT-01-60-DR-POM	160	145	20 x 18°	5.5	132	13
PRT-01-100-DR-POM	185	170	16 x 22.5°	5.5	162	13



delivery
time

available
from stock



prices

price list online
www.igus.co.uk/en/prt



order
example

part number
PRT-AZ-30

PRT-01-03-DR

PRT-01-03-DR-POM