

MEDWAY®

CLEVISES

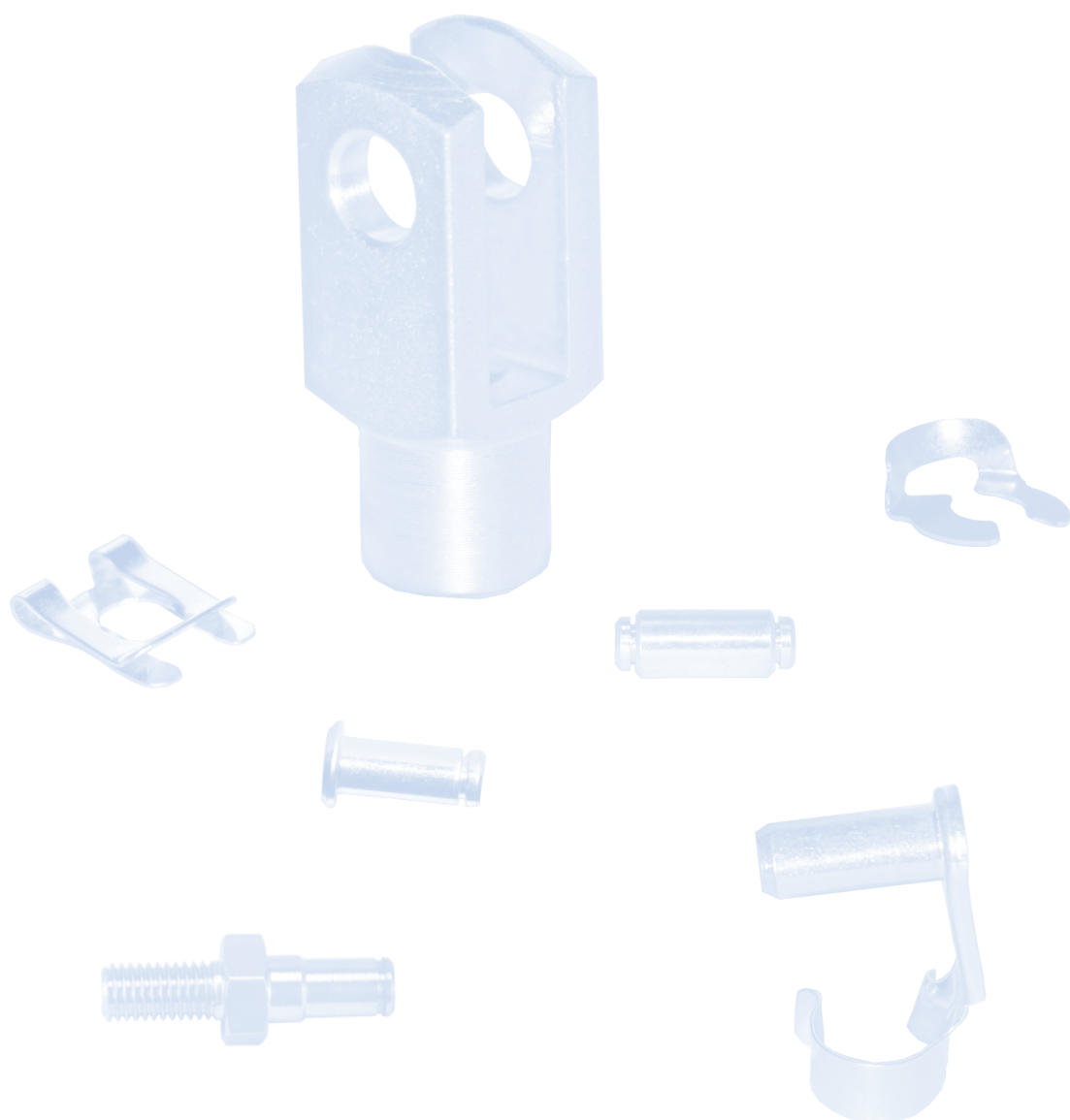

MEDWAY (UK) LIMITED

M.P.T. HOUSE BRUNSWICK ROAD COBBS WOOD INDUSTRIAL ESTATE ASHFORD KENT TN23 1EL U.K.
☎ +44 (0) 1233 663340 ☎ +44 (0) 1233 664440 ✉ sales@medway-uk.com 🌐 www.medway-uk.com

G - SERIES | GM - GI - GMSS

PAGE 1

Description

G - Series is our standard range of metric and imperial clevises also known as "Yoke" & "Fork" ends, in addition to our catalogue range we have produced over 2,000 special clevises to suit individual customer applications, therefore please enquire for any item not shown. Imperial sizes are easily identified by a groove on the tail. Stainless steel clevis assemblies are also available.

Metric sizes up to GML16 are used with ESM folding spring pins on page 4 or with NBM clevis pins on page 5. GM18 - GM30 are used with DEM clevis pins on page 6, size GM20 may also be used with ESM20 on page 4. Imperial sizes up to GIL625 are used with ESI folding spring pins on page 4 or with NBI clevis pins on page 5. GI750 - GI1000 are used with DEI clevis pins on page 6.

Materials

Clevis: Steel 230M07PB Zinc plated white & blue passivate (silver/clear) & Stainless steel 303C

Features

Metric & imperial thread & bore sizes
Standard & long series
Course & fine threads
No maintenance

Temperature Range

-40°C to +170°C

Possible Applications

Light to heavy industrial/mechanical applications
Construction equipment
Agricultural equipment
Industrial equipment

Specification

ELV & RoHS compliant



ES - SERIES | ESM - ESI

PAGE 4

Description

ES - Series is our standard range of metric and imperial folding spring pins for use with GM & GI Clevis joints, they are easily pre-assembled or removed by hand without the need for any tools.

ESM folding spring pins for use with GM series metric clevis joints.

ESI folding spring pins for use with GI series imperial clevis joints.

Materials

Pin: Steel 230M07PB Zinc plated white & blue passivate (silver/clear)

Spring: CS70 carbon steel, hardened and tempered & Zinc plated white & blue (Silver/clear) passivate

Features

Metric & imperial sizes
Standard & long series
No maintenance

Temperature Range

-40°C to +170°C

Possible Applications

Light - heavy industrial/mechanical applications
Construction equipment
Agricultural equipment
Industrial equipment

Specification

ELV & RoHS compliant



NB - SERIES | NBM - NBI

PAGE 5

Description

NBM - NBI series is our standard range of metric and imperial clevis pins for use with GM & GI Clevis joints.

NBM clevis pins for use with GM series metric clevis joints.

NBI clevis pins for use with GI series imperial clevis joints.

Materials

Pin: Steel 230M07PB Zinc plated white & blue passivate (silver/clear)

Features

Metric & imperial sizes
Standard & long series
No maintenance

Temperature Range

-40°C to +170°C

Possible Applications

Light to heavy industrial/mechanical applications
Construction equipment
Agricultural equipment
Industrial equipment

Specification

ELV & RoHS compliant



DE - SERIES | DEM - DEI

PAGE 6

Description

DEM - DEI series is our standard range of metric and imperial clevis pins for use with GM & GI Clevis joints.
DEM clevis pins are designed for use with GM18 - GM30 clevis Joints
DEI clevis pins are designed for use with GI750 - GI1000 clevis joints

Materials

Pin: Steel 230M07PB Zinc plated white & blue passivate (silver/clear)

Features

Metric & imperial sizes
Standard & long series
No maintenance

Possible Applications

Light to heavy industrial/mechanical applications
Construction equipment
Agricultural equipment
Industrial equipment

Temperature Range

-40°C to +170°C

Specification

ELV & RoHS compliant



AP - SERIES | AP - APL

PAGE 7

Description

AP-Series adaptor pins allow for an additional thread to be present once a clevis joint has been assembled, therefore making attachments possible.

Material Specifications

Pin: Steel 230M07PB Zinc plated white & blue passivate (silver/clear)

Features

Metric & imperial thread sizes
Safety features
Extended wear life
No maintenance

Possible Applications

Light to medium industrial/mechanical applications
Construction Equipment
Agricultural Equipment
Recreational vehicles

Temperature Range

-40°C to +170°C

Specification

ELV & RoHS compliant



SL - SERIES | SLM - SLI

PAGE 8

Description

SL - Series is our standard range of metric and imperial safety clips for use with GM & GI Clevis joints, they are easily pre-assembled or removed by hand without the need for any tools.

SLM safety clips are designed for use with NBM clevis pins.

SLI safety clips are designed for use with NBI clevis pins.

SLM16 is also compatible with DEM20 - DEM30.

SLM16 is also compatible with DEI750 - DEI1000.

Materials

Clip: CS70 carbon steel hardened and tempered & Zinc plated white & blue (Silver /clear) passivate

Features

Metric & imperial sizes
Safety lip prevents accidental removal
Assembly rattle is eliminated by the fastener holding the clevis pin under tension

Possible Applications

Light to heavy industrial/mechanical applications
Construction equipment
Agricultural equipment
Industrial equipment

Temperature Range

-40°C to +170°C

Specification

ELV & RoHS compliant



Description

KL - Series is our range of metric safety clips for use with GM Clevis joints, they are easily pre-assembled or removed by hand without the need for any tools, KLM retaining clips are designed as an alternative option to SLM safety clips.

KLM safety clips are designed for use with NBM clevis pins.

Materials

Clip: CS70 carbon steel hardened and tempered & Zinc plated white & blue (Silver /clear) passivate

Features

Metric sizes

Dished design ensures clip is under constant tension to minimise rattle

Temperature Range

-40°C to +170°C

Possible Applications

Light to heavy industrial/mechanical apps

Agricultural equipment

Industrial equipment

Construction equipment

Specification

ELV & RoHS compliant



NOTES |

All Metric clevis components are based on DIN 71752 and all imperial clevis components are based on DIN 71802.

40% of our total production is purpose made to suit individual customer requirements, therefore please do not hesitate to contact us for any item not shown or if you have a specific application, our engineering team are available to help you.

All of the above catalogue clevis components are ELV & RoHS compliant, all clevises, pins and clips are Zinc plated with white & blue passivate (Silver/Clear) specification suffix "F39" unless otherwise stated to give a surface protection of 96 hours salt spray, other plating options are available but may not be ELV & RoHS compliant, please refer to our "Plating Options" section for full details and availability.

Every care has been taken to ensure the accuracy of the information contained in the following pages of this publication. No liability can be accepted for any loss or damage whether direct or indirect or consequential arising out of the use of the information contained herein. The stated load rating and design options are provided as an indication only and customers should test the suitability of all products to their own satisfaction, applications vary immensely therefore samples are available for this purpose.

GM - SERIES STEEL CLEVIS JOINTS

Materials

Clevis: 230M07PB, Zinc plated white & blue passivate (silver/clear).

Specification

ELV & RoHS Compliant.

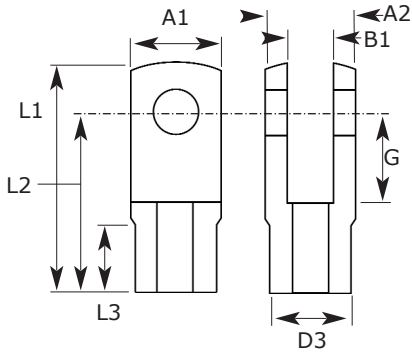

METRIC

PART NO. RIGHT HAND	PART NO. LEFT HAND	BORE SIZE*	THREAD	G	A1	A2	B1	D3	L1	L2	L3
GM4	GM4LH	4	M4X0.70	8	8	8	4	8	21	16	6.0
GML4	GML4LH	4	M4X0.70	16	8	8	4	8	29	24	6.0
GM5	GM5LH	5	M5X0.80	10	10	10	5	9	26	20	7.5
GML5	GML5LH	5	M5X0.80	20	10	10	5	9	36	30	7.5
GM6	GM6LH	6	M6X1.00	12	12	12	6	10	31	24	9.0
GML6	GML6LH	6	M6X1.00	24	12	12	6	10	43	36	9.0
GM8	GM8LH	8	M8X1.25	16	16	16	8	14	42	32	12.0
GM8C	GM8LHC	8	M8X1.00	16	16	16	8	14	42	32	12.0
GML8	GML8LH	8	M8X1.25	32	16	16	8	14	58	48	12.0
GML8C	GML8LHC	8	M8X1.00	32	16	16	8	14	58	48	12.0
GM10	GM10LH	10	M10X1.50	20	20	20	10	18	52	40	15.0
GM10C	GM10LHC	10	M10X1.25	20	20	20	10	18	52	40	15.0
GML10	GML10LH	10	M10X1.50	40	20	20	10	18	72	60	15.0
GML10C	GML10LHC	10	M10X1.25	40	20	20	10	18	72	60	15.0
GM12	GM12LH	12	M12X1.75	24	24	24	12	20	62	48	18.0
GM12C	GM12LHC	12	M12X1.25	24	24	24	12	20	62	48	18.0
GML12	GML12LH	12	M12X1.75	48	24	24	12	20	86	72	18.0
GML12C	GML12LHC	12	M12X1.25	48	24	24	12	20	86	72	18.0
GM14	GM14LH	14	M14X2.00	28	27	27	14	24	72	56	22.5
GM14C	GM14LHC	14	M14X1.50	28	27	27	14	24	72	56	22.5
GML14	GML14LH	14	M14X2.00	56	27	27	14	24	101	86	22.5
GML14C	GML14LHC	14	M14X1.50	56	27	27	14	24	101	86	22.5
GM16	GM16LH	16	M16X2.00	32	32	32	16	26	83	64	24.0
GM16C	GM16LHC	16	M16X1.50	32	32	32	16	26	83	64	24.0
GML16	GML16LH	16	M16X2.00	64	32	32	16	26	115	96	24.0
GML16C	GML16LHC	16	M16X1.50	64	32	32	16	26	115	96	24.0
GM18	GM18LH	18	M18X2.50	36	36	36	18	30	94	72	27.0
GM18C	GM18LHC	18	M18X1.50	36	36	36	18	30	94	72	27.0
GM20	GM20LH	20	M20X2.50	40	40	40	20	34	105	80	30.0
GM20C	GM20LHC	20	M20X1.50	40	40	40	20	34	105	80	30.0
GM25	GM25LH	25	M24X3.00	50	50	50	25	42	132	100	36.0
GM25C	GM25LHC	25	M24X2.00	50	50	50	25	42	132	100	36.0
GM28	GM28LH	28	M27X3.00	56	55	55	28	48	148	112	40.0
GM28C	GM28LHC	28	M27X2.00	56	55	55	28	48	148	112	40.0
GM30	GM30LH	30	M30X3.50	60	60	60	30	52	160	120	42.0
GM30C	GM30LHC	30	M30X2.00	60	60	60	30	52	160	120	42.0

Note: *Cross hole tolerance: +0.06 -0.00 mm

GI - SERIES STEEL CLEVIS JOINTS

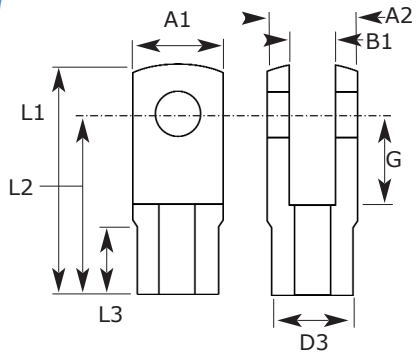

Materials

Clevis: 230M07PB, Zinc plated white & blue passivate (silver/clear).

Specification

ELV & RoHS Compliant.



IMPERIAL

PART NO. RIGHT HAND	PART NO. LEFT HAND	BORE SIZE*	THREAD	G	A1	A2	B1	D3	L1	L2	L3
GI187	GI187LH	3/16	10-32 UNF	0.394	0.375	0.375	0.1875	0.354	1.024	0.788	0.295
GIL187	GIL187LH	3/16	10-32 UNF	0.787	0.375	0.375	0.1875	0.354	1.417	1.181	0.295
GI250	GI250LH	1/4	1/4 UNF	0.472	0.500	0.500	0.2500	0.394	1.220	0.944	0.354
GIL250	GIL250LH	1/4	1/4 UNF	0.945	0.500	0.500	0.2500	0.394	1.693	1.417	0.354
GI312	GI312LH	5/16	5/16 UNF	0.630	0.630	0.630	0.3125	0.551	1.654	1.260	0.472
GIL312	GIL312LH	5/16	5/16 UNF	1.260	0.630	0.630	0.3125	0.551	2.283	1.890	0.472
GI375	GI375LH	3/8	3/8 UNF	0.787	0.750	0.750	0.3750	0.708	2.047	1.574	0.591
GIL375	GIL375LH	3/8	3/8 UNF	1.575	0.750	0.750	0.3750	0.708	2.834	2.362	0.591
GI500	GI500LH	1/2	1/2 UNF	1.102	1.000	1.000	0.5000	0.945	2.834	2.204	0.886
GIL500	GIL500LH	1/2	1/2 UNF	2.205	1.000	1.000	0.5000	0.945	3.976	3.346	0.886
GI625	GI625LH	5/8	5/8 UNF	1.260	1.250	1.250	0.6250	1.024	3.268	2.520	0.945
GIL625	GIL625LH	5/8	5/8 UNF	2.520	1.250	1.250	0.6250	1.024	4.528	3.780	0.945
GI750	GI750LH	3/4	3/4 UNF	1.575	1.575	1.575	0.7500	1.339	4.134	3.150	1.181
GI1000	GI1000LH	1	1 UNF	1.969	1.970	1.970	1.0000	1.654	5.197	3.938	1.417

Note: *Cross hole tolerance: +0.06 -0.00 mm.

Stainless steel materials such as 304, 314 & 316 are also available to order, please enquire for further information.

GM-SS ASSEMBLY SERIES STAINLESS STEEL CLEVIS JOINTS

Materials

Clevis: Stainless Steel 303L.

Clevis Pin: Stainless Steel 303L.

Washer: Stainless Steel 303L.

Split Pin: Stainless Steel 303L.

Specification

ELV & RoHS Compliant.

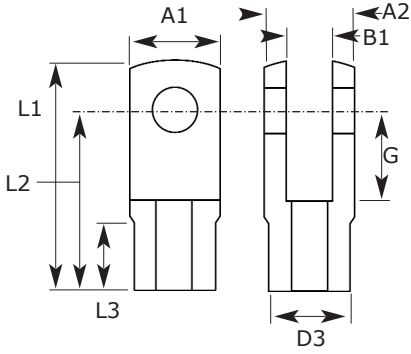

METRIC

PART NO. RIGHT HAND	PART NO. LEFT HAND	BORE SIZE*	THREAD	G	A1	A2	B1	D3	L1	L2	L3
GM4SS-ASSY	GM4LHSS-ASSY	4	M4X0.70	8	8	8	4	8	21	16	6.0
GML4SS-ASSY	GML4LHSS-ASSY	4	M4X0.70	16	8	8	4	8	29	24	6.0
GM5SS-ASSY	GM5LHSS-ASSY	5	M5X0.80	10	10	10	5	9	26	20	7.5
GML5SS-ASSY	GML5LHSS-ASSY	5	M5X0.80	20	10	10	5	9	36	30	7.5
GM6SS-ASSY	GM6LHSS-ASSY	6	M6X1.00	12	12	12	6	10	31	24	9.0
GML6SS-ASSY	GML6LHSS-ASSY	6	M6X1.00	24	12	12	6	10	43	36	9.0
GM8SS-ASSY	GM8LHSS-ASSY	8	M8X1.25	16	16	16	8	14	42	32	12.0
GM8CSS-ASSY	GM8LHCSS-ASSY	8	M8X1.00	16	16	16	8	14	42	32	12.0
GML8SS-ASSY	GML8LHSS-ASSY	8	M8X1.25	32	16	16	8	14	58	48	12.0
GML8CSS-ASSY	GML8LHCSS-ASSY	8	M8X1.00	32	16	16	8	14	58	48	12.0
GM10SS-ASSY	GM10LHSS-ASSY	10	M10X1.50	20	20	20	10	18	52	40	15.0
GM10CSS-ASSY	GM10LHCSS-ASSY	10	M10X1.25	20	20	20	10	18	52	40	15.0
GML10SS-ASSY	GML10LHSS-ASSY	10	M10X1.50	40	20	20	10	18	72	60	15.0
GML10CSS-ASSY	GML10LHCSS-ASSY	10	M10X1.25	40	20	20	10	18	72	60	15.0
GM12SS-ASSY	GM12LHSS-ASSY	12	M12X1.75	24	24	24	12	20	62	48	18.0
GM12CSS-ASSY	GM12LHCSS-ASSY	12	M12X1.25	24	24	24	12	20	62	48	18.0
GML12SS-ASSY	GML12LHSS-ASSY	12	M12X1.75	48	24	24	12	20	86	72	18.0
GML12CSS-ASSY	GML12LHCSS-ASSY	12	M12X1.25	48	24	24	12	20	86	72	18.0
GM14SS-ASSY	GM14LHSS-ASSY	14	M14X2.00	28	27	27	14	24	72	56	22.5
GM14CSS-ASSY	GM14LHCSS-ASSY	14	M14X1.50	28	27	27	14	24	72	56	22.5
GML14SS-ASSY	GML14LHSS-ASSY	14	M14X2.00	56	27	27	14	24	101	86	22.5
GML14CSS-ASSY	GML14LHCSS-ASSY	14	M14X1.50	56	27	27	14	24	101	86	22.5
GM16SS-ASSY	GM16LHSS-ASSY	16	M16X2.00	32	32	32	16	26	83	64	24.0
GM16CSS-ASSY	GM16LHCSS-ASSY	16	M16X1.50	32	32	32	16	26	83	64	24.0
GML16SS-ASSY	GML16LHSS-ASSY	16	M16X2.00	64	32	32	16	26	115	96	24.0
GML16CSS-ASSY	GML16LHCSS-ASSY	16	M16X1.50	64	32	32	16	26	115	96	24.0
GM18SS-ASSY	GM18LHSS-ASSY	18	M18X2.50	36	36	36	18	30	94	72	27.0
GM18CSS-ASSY	GM18LHCSS-ASSY	18	M18X1.50	36	36	36	18	30	94	72	27.0
GM20SS-ASSY	GM20LHSS-ASSY	20	M20X2.50	40	40	40	20	34	105	80	30.0
GM20CSS-ASSY	GM20LHCSS-ASSY	20	M20X1.50	40	40	40	20	34	105	80	30.0
GM25SS-ASSY	GM25LHSS-ASSY	25	M24X3.00	50	50	50	25	42	132	100	36.0
GM25CSS-ASSY	GM25LHCSS-ASSY	25	M24X2.00	50	50	50	25	42	132	100	36.0
GM28SS-ASSY	GM28LHSS-ASSY	28	M27X3.00	56	55	55	28	48	148	112	40.0
GM28CSS-ASSY	GM28LHCSS-ASSY	28	M27X2.00	56	55	55	28	48	148	112	40.0
GM30SS-ASSY	GM30LHSS-ASSY	30	M30X3.50	60	60	60	30	52	160	120	42.0
GM30CSS-ASSY	GM30LHCSS-ASSY	30	M30X2.00	60	60	60	30	52	160	120	42.0

Note: *Cross hole tolerance: +0.06 -0.00 mm. Stainless steel materials such as 304, 314 & 316 are also available to order, please enquire for further information.

ESM - SERIES FOLDING SPRING PINS CLEVIS JOINTS

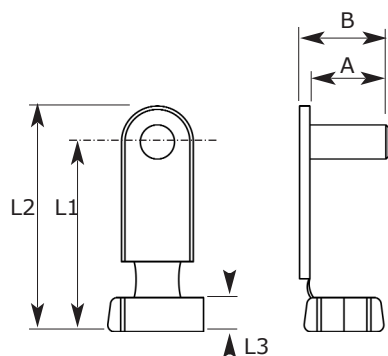

Materials

Pins: 230M07PB, hardened & Zinc plated white & blue passivate (silver/clear).

Spring: C60, Zinc plated white & blue passivate (silver/clear).

Specification

ELV & RoHS Compliant.



METRIC

PART NO.	PIN SIZE	A	B	L1	L2	L3
ESM4	4	9.5	11.0	15.0	18.5	4.5
ESM5	5	12.0	13.5	19.0	23.0	5.5
ESML5	5	12.0	13.5	29.0	33.0	5.5
ESM6	6	14.0	16.0	23.0	28.0	6.5
ESML6	6	14.0	16.0	35.0	40.0	6.5
ESM8	8	19.0	21.5	30.0	36.5	8.0
ESML8	8	19.0	21.5	46.0	52.0	8.0
ESM10	10	23.0	26.0	38.0	45.0	10.0
ESML10	10	23.0	26.0	58.0	65.0	10.0
ESM12	12	28.0	31.0	45.0	53.0	12.0
ESML12	12	28.0	31.0	69.0	78.0	12.0
ESM14	14	29.4	34.0	52.0	62.0	14.0
ESML14	14	29.4	34.0	82.0	91.0	14.0
ESM16	16	36.0	39.0	62.0	73.5	16.0
ESML16	16	36.0	39.0	92.0	103.0	16.0
ESM20	20	44.0	49.0	71.0	88.0	16.0

IMPERIAL

ESI - SERIES FOLDING SPRING PINS CLEVIS JOINTS

PART NO.	PIN SIZE	A	B	L1	L2	L3
ESI187	3/16	0.430	0.490	0.900	0.750	0.220
ESIL187	3/16	0.430	0.490	1.300	1.140	0.220
ESI250	1/4	0.560	0.640	1.100	0.900	0.250
ESIL250	1/4	0.560	0.640	1.570	1.380	0.250
ESI312	5/16	0.700	0.790	1.430	1.180	0.310
ESIL312	5/16	0.700	0.790	2.050	1.810	0.310
ESI375	3/8	0.830	0.950	1.770	1.500	0.390
ESIL375	3/8	0.830	0.950	2.560	2.280	0.390
ESI500	1/2	1.090	1.210	2.440	2.050	0.550
ESIL500	1/2	1.090	1.210	3.580	3.230	0.550
ESI625	5/8	1.350	1.470	2.890	2.440	0.630
ESIL625	5/8	1.350	1.470	4.050	3.620	0.630

NBM - SERIES STEEL CLEVIS PINS

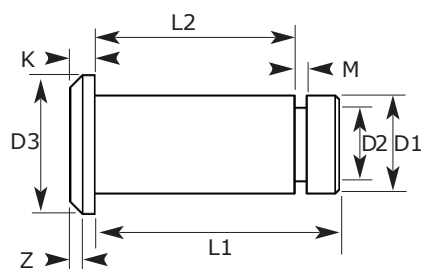

Materials

Pin: 230M07PB, Zinc plated white & blue passivate (silver/clear).

Specification

ELV & RoHS Compliant.



METRIC

PART NO.	PIN SIZE D1	D2	D3	K	M	Z	L1	L2
NBM4	4	3.2	6	1.5	0.74	0.75	10.35	8.25
NBM5	5	4.1	8	1.0	0.84	0.50	12.85	10.25
NBM6	6	5.1	9	1.5	0.84	0.75	15.35	12.25
NBM8	8	6.1	12	2.0	1.04	1.00	19.85	16.25
NBM10	10	8.2	14	2.5	1.15	1.25	24.85	20.25
NBM12	12	9.2	16	3.0	1.25	1.25	29.35	24.25
NBM14	14	10.2	18	3.0	1.35	1.25	32.85	27.25
NBM16	16	12.2	20	3.5	1.45	1.50	38.35	32.25

NBI - SERIES STEEL CLEVIS PINS

IMPERIAL

PART NO.	PIN SIZE D1	D2	D3	K	M	Z	L1	L2
NBI187	3/16	0.140	0.250	0.050	0.028	0.030	0.480	0.385
NBI250	1/4	0.193	0.343	0.062	0.034	0.030	0.625	0.510
NBI312	5/16	0.240	0.437	0.078	0.041	0.040	0.770	0.635
NBI375	3/8	0.301	0.500	0.090	0.045	0.050	0.932	0.760
NBI500	1/2	0.388	0.625	0.110	0.054	0.060	1.223	1.010
NBI625	5/8	0.480	0.781	0.120	0.057	0.060	1.491	1.260

DEM - SERIES STEEL CLEVIS PINS

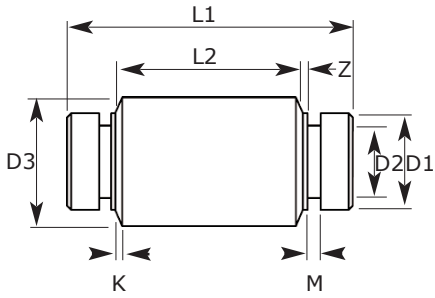

Materials

Pin: 230M07PB, Zinc plated white & blue passivate (silver/clear).

Specification

ELV & RoHS Compliant.

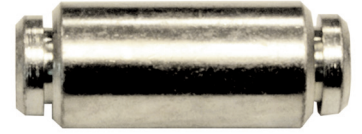

METRIC

PART NO.	D1	D2	PIN SIZE D3	K	M	Z	L1	L2	OTHER ITEMS REQUIRED
DEM20	15.87	12.2	20	1.5	1.35	NO SHOULDER	52.22	40.50	2 X SLM16 (ONLY)
DEM25	15.87	12.2	25	1.5	1.35	2.08	66.38	50.50	2 X SLM16+ 2 X M7105
DEM30	15.87	12.2	30	1.5	1.35	3.75	79.72	60.50	2 X SLM16 + 2 X M7107

DEI - SERIES STEEL CLEVIS PINS

IMPERIAL

PART NO.	D1	D2	PIN SIZE D3	K	M	Z	L1	L2	OTHER ITEMS REQUIRED
DEI750	0.625	0.480	0.75	0.04	0.053	NO SHOULDER	2.066	1.594	2 X SLM16 (ONLY)
DEI1000	0.625	0.480	1.00	0.06	0.053	0.082	2.624	1.988	2 X SLM16 + 2 X M7105

ADAPTOR PIN - SERIES

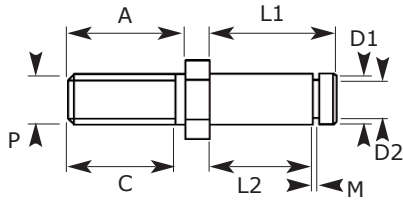

Materials

Stud: Hardened 230M07PB, Zinc plated white & blue passivate (silver / clear).

Specification

ELV & RoHS Compliant.



METRIC

PART NO. RIGHT HAND	THREAD	D1	D2	M	A/F	A	C	L1	L2
AP-M05	M5/0.80	5.0	4.1	0.84	8.0	10.2	8.2	10.75	8.25
APL-M05	M5/0.80	5.0	4.1	0.84	8.0	10.2	8.2	12.85	10.25
AP-M06	M6/1.00	6.0	5.1	0.84	10.0	12.5	10.5	12.25	9.25
APL-M06	M6/1.00	6.0	5.1	0.84	10.0	12.5	10.5	15.35	12.25
AP-M08	M8/1.25	8.0	6.1	1.04	13.0	16.5	14.5	15.75	12.25
APL-M08	M8/1.25	8.0	6.1	1.04	13.0	16.5	14.5	19.85	16.25
AP-M10	M10/1.50	10.0	8.2	1.15	16.0	20.0	18.0	18.75	14.25
APL-M10	M10/1.50	10.0	8.2	1.15	16.0	20.0	18.0	24.85	20.25
AP-M12	M12/1.75	12.0	9.2	1.25	18.0	20.0	18.0	21.25	16.25
APL-M12	M12/1.75	12.0	9.2	1.25	18.0	20.0	18.0	29.35	24.25

IMPERIAL

PART NO. RIGHT HAND	THREAD	D1	D2	M	A/F	A	C	L1	L2
AP-03	10-32 UNF	3/16	0.140	0.028	0.315	0.402	0.323	0.417	0.322
APL-03	10-32 UNF	3/16	0.140	0.028	0.315	0.402	0.323	0.480	0.385
AP-04	1/4 UNF	1/4	0.193	0.034	0.394	0.492	0.413	0.479	0.364
APL-04	1/4 UNF	1/4	0.193	0.034	0.394	0.492	0.413	0.625	0.510
AP-05	5/16 UNF	5/16	0.240	0.041	0.512	0.650	0.570	0.619	0.484
APL-05	5/16 UNF	5/16	0.240	0.041	0.512	0.650	0.570	0.770	0.635
AP-06	3/8 UNF	3/8	0.301	0.045	0.630	0.787	0.709	0.733	0.561
APL-06	3/8 UNF	3/8	0.301	0.045	0.630	0.787	0.709	0.932	0.760
AP-08	1/2 UNF	1/2	0.388	0.054	0.708	0.787	0.709	0.853	0.640
APL-08	1/2 UNF	1/2	0.388	0.054	0.708	0.787	0.709	1.223	1.010

SLM - SERIES SPRING STEEL SAFETY CLIP

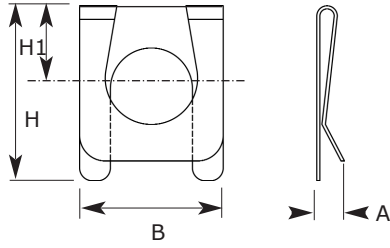

Materials

Safety clip: Spring steel, Zinc plated white & blue passivate (silver/clear), Hardened and annealed to 1450 to 1600 N/mm² tensile strength.

Specification

ELV & RoHS Compliant.



METRIC

PART NO.	PIN SIZE	B	H	H1	A	THICKNESS	MAX AXIAL THRUST (n)
SLM4	4	7.0	7.50	4.0	2.2	0.30	1,000
SLM5	5	9.0	11.00	4.5	2.3	0.35	1,300
SLM6	6	11.0	14.25	6.0	3.3	0.40	1,500
SLM8	8	14.0	17.25	8.0	3.5	0.45	3,600
SLM10	10	18.0	21.75	10.3	4.6	0.50	6,400
SLM12	12	22.0	25.50	12.0	4.6	0.50	9,600
SLM14	14	25.1	30.10	13.5	5.8	0.60	11,320
SLM16	16	28.0	34.00	16.0	5.8	0.60	13,500

SLI - SERIES SPRING STEEL SAFETY CLIP

IMPERIAL

PART NO.	PIN SIZE	B	H	H1	A	THICKNESS	MAX AXIAL THRUST (n)
SLI187	3/16	0.355	0.429	0.195	0.084	0.0135	1,300
SLI250	1/4	0.437	0.562	0.245	0.130	0.0150	1,500
SLI312	5/16	0.551	0.679	0.315	0.138	0.0170	3,600
SLI375	3/8	0.710	0.844	0.385	0.211	0.0190	6,400
SLI500	1/2	1.000	1.200	0.520	0.263	0.0230	9,600
SLI625	5/8	1.102	1.338	0.630	0.228	0.0230	13,500

KLM - SERIES SPRING STEEL SAFETY CLIP

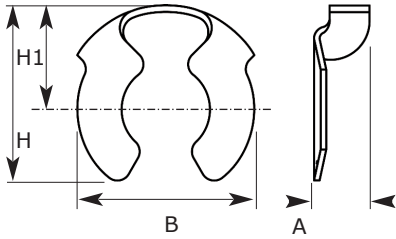

Materials

Safety clip: Spring steel, Zinc plated white & blue passivate (silver/clear), Hardened and annealed to 1450 to 1600 N/mm² tensile strength.

Specification

ELV & RoHS Compliant.

Notes

Dimensions may vary slightly in line with DIN Standards.



METRIC

PART NO.	PIN SIZE	B	H	H1	A	THICKNESS	MAX AXIAL THRUST (n)
KLM4	4	6.8	7.0	4.3	2.6	0.30	1,500
KLM5	5	7.7	8.4	5.2	2.8	0.40	3,000
KLM6	6	10.6	11.7	6.8	3.5	0.40	4,850
KLM8	8	11.5	11.8	7.4	4.0	0.45	5,500
KLM10	10	15.5	15.9	9.5	5.0	0.50	9,500
KLM12	12	17.2	18.5	11.5	6.0	0.50	10,700
KLM14	14	19.7	20.0	11.9	6.7	0.60	12,700
KLM16	16	23.2	24.5	14.6	7.0	0.60	14,000
KLM24	24	34.0	34.0	18.5	9.0	0.60	15,000