

PIC[®] DESIGN

Catalog 45

The Inch & Metric
Source

Precision Mechanical
Components

Motion/Positioning
Products

Gear Products



Interactive Catalog On-Line Ordering
www.pic-design.com
CAD Files

Over 50 Years
Service - Quality - Integrity



Call
800-243-6125

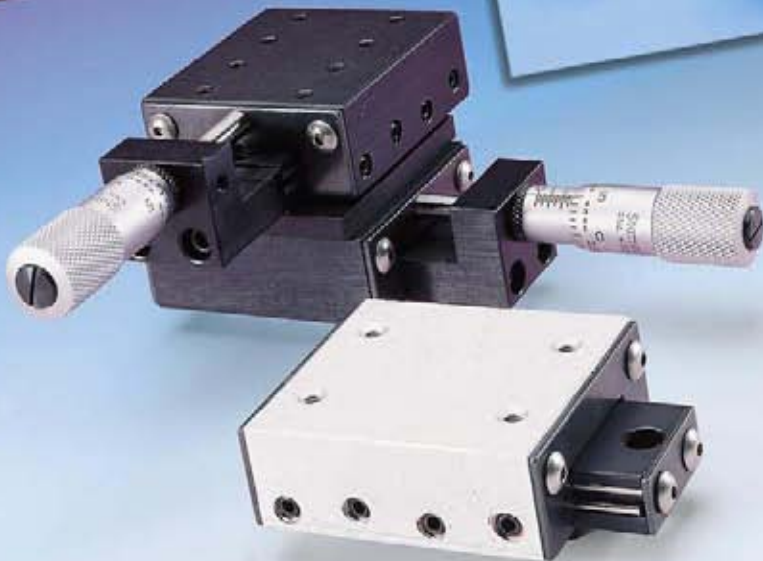

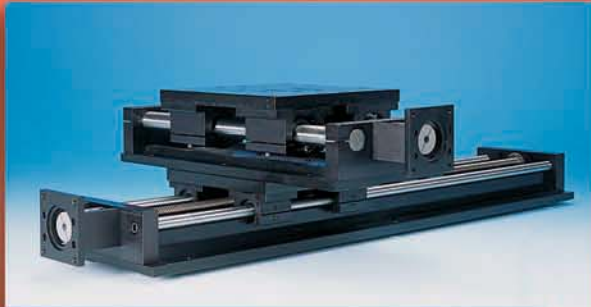

“Twin Track” Linear Motion System

They're part of the family of PIC Linear Motion Systems. All systems come fully assembled. Ten configurations are available along with an easy-to-use guide — all detailed in Section 1 of this catalog.



Positioning Tables Available The Way You Need Them

Without breaking the bank, get features hard to find elsewhere. Travel lengths to 12 inches with a lead screw that suits your application. Configure them into X, X-Y, X-Y-Z systems with manual or motor-ready operation.



Inch/Metric Universal Lateral Shaft Couplers

These new lateral shaft couplers are part of a large and growing family of couplings. Choose from 16 styles to satisfy most applications. Refer to our Coupling Selection Guide in Section 7. You'll see how easy it is to select the proper coupler.



Belt Field Splicing Kit Is Easy To Use Two New Pitch Sizes Added To Belt Line

Now easily splice No-Slip, No-Slide belts using this simple kit. It comes with complete instructions. It's the perfect choice for those doing field repairs and prototyping.

Also checkout our expanded product line of belts now including two new pitches — 24DP and .25". All PIC belts and pulleys are available on Autodesk's PartSpec. Use PartSpec and find out how easy it is to calculate belt center distances.



PIC-STIX Framing Elements Make Support Construction Easy

The PIC-STIX line just doubled in size with the addition of our new line of light-weight miniature extrusions. It's now easier than ever to construct structural assemblies using simple hand tools. Why pay for customized constructions when you can do it yourself.

***“Twin Track”
Linear Motion
System***

Not only does “Twin Track” represent a significant price breakthrough, but it also offers users a host of design features not previously available in a single system. Twin Track is designated as System 10 and is fully described in Section 1 of this catalog. System 10 is available pre-assembled with many options to choose from.

A one-piece plate and rail support assures parallelism and ease of set-up. Misalignment is

eliminated because independent supports are no longer employed. Although standardized, System 10 provides enhanced versatility because it is available in a choice of 10 travel lengths and 13 different lead screws. Motor mounts conform to either NEMA 23 or 34. A hand crank version is also offered.

Self-aligning recirculating ball bearings or economical engineered plastic bearings further add to the versatility of System 10.

***Positioning
Tables With
Extended Travel
Lengths***

PIC delivers again on its promise of providing economically priced positioning tables without sacrificing quality. (See Section 1 of this catalog.) Straight line accuracy is .0007 inches per inch of travel. Repeatability and lead accuracy are .0004 inches and .003 inches per foot, respectively. Best of all, travel lengths now range from 2 to 12 inches.

Combine these positioning tables to form X-Y systems. Add a bracket and you can configure an X-Y-Z system. Get them with or without motor mounts and with a broad range of lead screw options. And now with a load handling capability of over 100 pounds, they're more versatile than ever.

***Universal Lateral
Shaft Couplers
Now Feature
Inch/Metric
Models***

The PIC family of universal lateral couplings now feature 27 bore combinations, providing flexible coupling of inch-to-inch, metric-to-metric, and inch-to-metric shafts. See Section 7 for complete product details.

PIC universal lateral couplings compensate for both lateral and angular misalignments of .050 inch and 10°, respectively. Delrin constructed bodies

provide effective electrical insulation. Hubs are fabricated in nickel plated zinc for corrosion resistance.

PIC universal lateral couplings are competitively priced, compactly designed to save space, and require no maintenance or lubrication.

***Finished Belt
Fabrication Is
Easy With New
Splicing Kit***

PIC Design has always been the acknowledged leader in the design and fabrication of high performance positioning belts and pulleys, described in Section 5 of this catalog. To complement our line of No-Slip and No-Slide belts, we now offer a new series of Belt Field Splicing Kits. Belts can now be assembled in the field from bulk stock. This capability is particularly useful for those engaged in prototyping operations or repair.

The kit consists of a ratcheting plier, belt positioning fixture, knife, stripper/cutter, and a supply of ferrules. The fixture assures that the belt pitch will be accurate over the splice area. The ratcheting plier-die set combination assures a consistently crimped ferrule.

To add flexibility, other belt configurations can be crimped by simply purchasing the appropriate positioning fixture and a supply of ferrules.

***PIC-STIX
Modular Framing
Elements***

The PIC-STIX family of structural construction components has been doubled in size by the addition of new light-weight miniature extrusion and associated hardware. See Section 9 of this catalog for the whole story and find out how easy it is to construct a wide range of structures using simple hand tools. T-slots in the extruded members easily accept T-bolts and T-nuts for fastening.

PIC can ship the extrusions pre-cut to your size or in bulk lengths. We'll even ship complete kits or finished assemblies. PIC-STIX are the ideal way to quickly construct machine supports, platforms for linear motion systems, safety guards, and robotic systems.

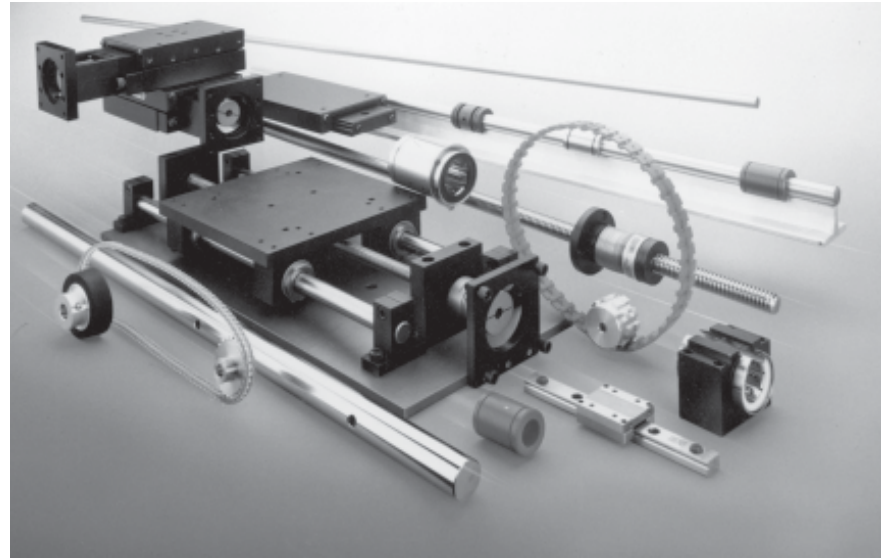

MOTION / POSITIONING PRODUCTS

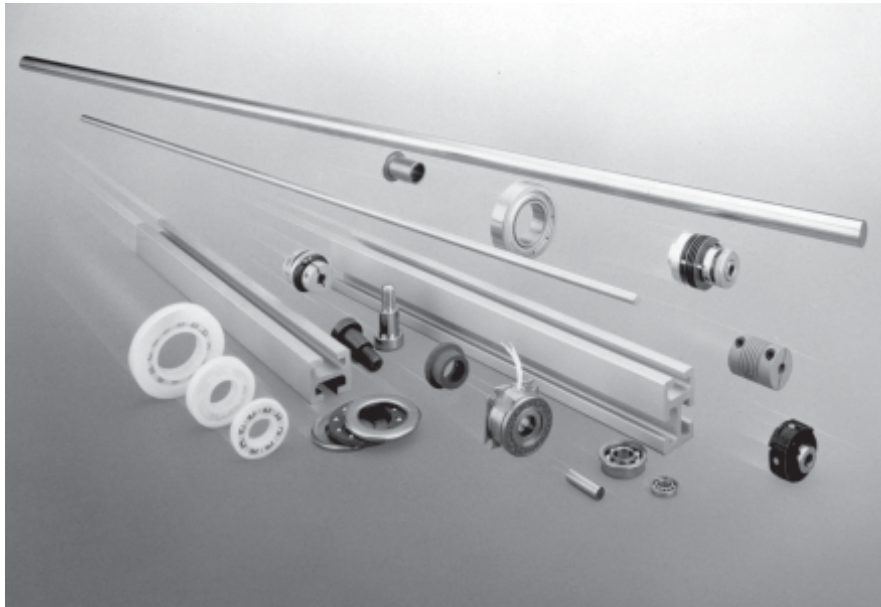

PRECISION MECHANICAL COMPONENTS

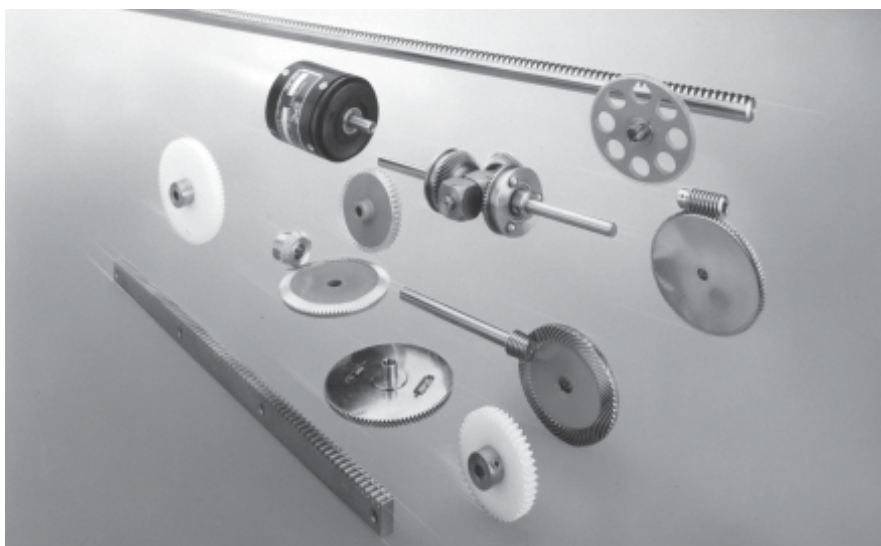

GEAR PRODUCTS

TABLE OF CONTENTS

SECTION

LINEAR MOTION SYSTEMS	Design Guide Pre-Assembled/Assembled System & Sub-System Positioning Stages	Carrage Top Mount Adapters	1
LINEAR SLIDES AND INTERMITTENT MOTION	Slides Geneva Mechanisms	Ball Slides Positioners Recirculating Slide Guides Crossed Roller Slides	2
LEAD SCREW	Precision PS & Acme Style Bearing Housing Blocks	Screws Power Nuts Anti-Backlash Nuts and Accessories	3
LINEAR MOTION COMPONENTS	Shafting Shaft Supports Linear Bearings Precision Rubber Rollers	Precision ground steel dies Hubs Hangers Recirculating Ball Flanged Plastic Ceramic Housings-Pulley Blocks	4
BELTS AND PULLEYS	Positioning Timing Round Chain	No-Slip No-Slide Tapered pulleys	5
BEARINGS	Ball Sleeve Thrust Shafting	Extended Life Balls Tapered O.D. Extra Thin ABEC 7, 8 & 9 Plain & Flanged Non-Corrosive Spherical Sealed Bronze Non-Metallic Teflon Bearings and Washers Precision Ground Hardened Threaded	6
CLUTCHES, BRAKES AND COUPLINGS	Brakes Clutches Couplings	Power Off Power On Spring & Magnetic Elastic Slip Adjustable Roller Slip Belts Zero Adjustable Flexible Universal Lateral Multi-Jaw Miniature Clutch Water Spring Universal Slowed Frictional-Zero Backlash 1:1 Bolt Reducers	7
PRECISION HARDWARE	Fasteners & Washers Accessories Pins Springs	Stainless Steel & Machine Screws Ball Bead Spring Plain Lock and Conical Washers Metric Metric Chalk Handles Die's Head Cranks Kicks Standoffs Dowel Taper Springs Spring Grooved Collar Compression Extension Experimental	8
MODULAR FRAMING ELEMENTS-STRUCTURAL EXTRUSIONS	Extrusions Mounting Hardware Accessories	1X1, 1X2, 2X2 Miniature, 1X1, 1X1.5, 1.5X1.5, 1.5X3,3X3 Standard, Brackets, Fasteners, Handles, Casters, Hinges etc.	9
EDUCATIONAL KITS AND PRECISION TOOLS		Precision Mechanical Component Kits, Socket Head Key Set	10
SPEED REDUCERS AND GEAR HEADS	Speed Reducers Gear Boxes	Gear Heads Sawtooth Worm & Wheel Planetary Miter and Bevel	11
GEARS	Spur Specialty Racks	Stainless Steel Aluminum Delrin Plastic Hubs Anti-Backlash Helical Worm Miter & Bevel Spiral Cluster Differentials Pinion Shafts Barks Precision Bevel gear Round	12
TECHNICAL SECTION		Gear Technology and Formulas Backlash and Strength Calculations AGMA and MIL Specifications Engineering Data	13
ALPHABETICAL INDEX			14

CATALOG SERIES INDEX

If a Part Number is known, this index will assist in identifying and locating the part in the Catalog.

CATALOG SERIES	DESCRIPTION	SECTION PAGE	CATALOG SERIES	DESCRIPTION	SECTION PAGE	CATALOG SERIES	DESCRIPTION	SECTION PAGE
A1 to A8	Shafts, Precision Ground	6-22 to 6-23	D40 to D50	Pins-Dowel-Interference Fit	8-14	K2-1 to K2-14	Hubs-Gear & Dial-Split Type	12-67
A9	Rod, Threaded	6-21	D6-1 to -6	Washers-Wave Spring	6-14	K2-50 to K2-52A	Hubs-5/16 to 1/2 Bores Split Type	12-68
A10	Shafting - Hardended	4-3 & 6-25	D6-20 to -27	Washers-Belleville Spring	8-8	KE	Kits-Educational	10-1 & 10-2
A10-D	Shafting - Hardened Predrilled	4-4	DJ & DQ	Worm & Wheel Assemblies	11-4	L1, L4, L5, L6	Clamps-Hub,Standard & Miniature	6-19 & 6-20
A10L	Shafting - Hardened	4-3 & 6-25	DU	Helical Gear Assemblies	11-5	L2, L3	Cleats-Motor Mount	8-12 & 8-13
A10-X-SR	Shaft and Support Rails Assemblies	4-5	E1 to E19	Bearings-Ball, Precision	6-4 & 6-5	LMB	Flange-Lead Screw	3-13
A11	Shafting - 303 S.S.	4-3 & 6-25	E1 to E4	Bearings-Extended Inner Race	6-3	LS3- to LS10	Linear Systems	1-5 to 1-11
A11-X-SR	Shafting and Support Rail Assemblies	4-5	E5	Bearings-Extra Thin	6-3	M1 to M5	Dials-Disc & Drum; Index	8-22 to 8-24
A12	Shafting 440C S.S.	4-3, 4-8 & 6-25	E8	Bearings-Tapered O.D.	6-3	MA10	Shafting - Hardened	4-3 & 6-25
A12-D	Shafting - 404C S.S. Pre drilled	4-4	EC	Roller Clutches	7-7	MA10-D	Shafting Hardened - Predrilled	4-4
A12-X-SR	Shaft and Support Rail Assemblies	4-5	EF	Handles-Chassis	8-20 & 8-21	MA10-X-SR	Shaft and Support Rail Assemblies	4-5
AA	Bearing Housings	6-14	EG	Spacer Post-Threaded	8-13	MA11	Shafting 303 S.S.	4-3 & 6-25
AB	Gears-Spur, Non-Metallic	12-31 to 12-34	EG-375 to 625B	Non-Corrosive Ball Bearing	6-10	MA11-X-SR	Shaft and Support Rail Assemblies	4-5
AC,AD	Gears-Helical	12-45	EJ,EK	Gears-Spiral	12-52	MA12	Shafting 440C S.S.	4-3 & 6-25
ACS	Shafting for Instrument Linear Bearings	4-8	EL	Chain-Miniature Pitch	5-41	MA12-X-SR	Shaft and Support Rail Assemblies	4-5
AE5 to AE18	Pulleys-Grooved	5-38 to 5-40	EL25	Chain-.250 Pitch	5-41	MBF & MBS	Non-Metallic Bearings	6-9
AF2 to AF6	Round Belt	5-38 to 5-40	EM	Sprockets-Chain	5-42	MBG1 to MBG8	Bearings-Ball,Precision (Extra Small and Standard)	6-5
AG	Racks-Precision	12-29 & 12-30	EM25	Sprockets-Chain	5-41	MBG9 to MBG10	Bearings-Bronze, Oil Impregnated	6-7
AH,AJ	Washers-Thrust	6-11	EPS-A	Timing Belts-.080 Pitch	5-26	MBG10 - MBG40	Bearings - Ball ISO Normal	6-5
AK,AL	Balls-Steel, Nylon	6-18	EPS-C	Timing Belts-.0816 Pitch	5-28	MBL1	Balls-Precision, Hardened	6-18
AM	Bearings-Bronze,Precision	6-11	EPS-D	Timing Belts-1/5 Pitch	5-30	MBLA	Linear Bearings Ceramic Coated Adjustable	4-12
ANR1	ACME Power Nuts	3-10	EPS-F	Timing Belts-3mm	5-34	MBLC	Linear Bearings Ceramic Coated Closed	4-12
ANR2	ACME Anti-Backlash Nuts	3-11	EPS-G	Timing Belts-5mm	5-36	MBLO	Linear Bearings Ceramic Coated Open	4-12
ANR3	Acme Adjustable Compliant Nut	3-12	EPS-J	Timing Belts-3/8 Pitch	5-33	MBW1	Washers-Belleville Spring	8-8
AP-3	Mounting Plate-Bearing	6-14	ES	Gear Boxes-Servo	11-4	MCH2 to MCH4	Clutches-Slip,Continuous, Adjustable, Intermittent	7-4 & 7-6
ARS	ACME Lead Screws	3-9	ES-250 to 1000	Non-Corrosive Ball Bearing	6-10	MCS1	Screws-Captive, Slotted Head	8-9
AU	Shaft Extensions	6-21	ET	Thrust Bearings	6-11	MCU1 & MCU2	Couplings-Bellows	7-9
AW,AX	Dial Sets-Disc & Drum	8-22 & 8-23	EU	Geneva Mechanisms	11-7 & 11-8	MCU3 & MCU4	Couplings-Zero Adjustable	7-9
AY,AZ	Springs-Compression Extension	8-19	EV	Intermittent Motion Assembly	11-6	MCU5 & MCU6	Couplings-Sleeve	7-12
B1,B2	Spacers,Shim-Laminated Brass	6-18	F1,F2,F3	Spacer Posts-Square	8-13	MCU7 & MCU8	Couplings-Flexible	7-10
B3	Spacers,Shim-Outer Race	6-16	F4 to F9	Gears-Pinion Shafts	12-28	MCU9 & MCU10	Couplings-Oldham	7-11
B4 to B15	Spacers,Shim-Precision	6-17	F8BS	No-Slide Belts-40DP	5-20	MCU13 & MCU14	Couplings-Multi Jaw	7-11
B10,B11	Bearings,Bronze-Oil Impregnated	6-6	F8P	No-Slide Pulleys-40DP	5-20	MCU15	Couplings-Wafer Spring	7-8
B14,B15	Bearings, Sleeve-Teflon	6-10	F20B	No-Slide Belts-1/5" Pitch	5-21	MCU17 - MCU19	Couplings-Slip, Continuous, One Way Adjustable	7-5 & 7-6
BA	Miter & Bevel Gear Boxes	11-5	F20P	No-Slide Pulleys-1/5" Pitch	5-21	MCU20	Couplings- Sleeve	7-12
BB	Breadboard Components	8-25	F20T	No-Slip Belts-Triple Core 20DP	5-14	MDP1 to MDP20	Pins-Dowel, Precision	8-15
BC	Universal Joints	7-15	F24	No-Slip Belts-24DP	5-10	MEG & MES	Non-Corrosive Ball Bearing	6-10
BE-1 to BE-3	Set Screw-Slotted Head	8-7	F24G	No-Slip Sprockets-24DP	5-11	MF8	No-Slide Pulley-40DP Metric Bores	5-20
BE-16,-66,-67	Springs-Anti-Backlash	8-21	F25CS	No-Slip Belts-1/4CP	5-18	MF20G	No-Slip Sprocket-20DP Metric Bores	5-15
BFC	Ball Screw Mounting Flanges	3-16 - 3-20	F25G	No-Slip Sprockets-1/4CP	5-19	MF20P	No-Slide Pulley-1/5" Pitch Metric Bores	5-21
BN	Ball Screw Nuts	3-16 - 3-20	F32CS	"No Slip" Belts-32DP-Twin Core	5-8	MF24G	No-Slip Sprockets-24DP Metric Bores	5-11
BNW	Ball Screw Wipers	3-16 - 3-20	F32G,F32J	"No Slip" Pulleys-32DP-Twin Core	5-9	MF25G	No-Slip Sprockets-1/4"CP Metric Bores	5-19
BF, BS	Non-Metallic Bearings	6-8	F37B	No-Slide Belts-3/8 Pitch	5-22	MF32	No-Slip Sprockets-32DP Metric Bores	5-9
BG	Knobs	8-25	F37P	No-Slide Pulleys-3/8 Pitch	5-22	MF37P	No-Slide Pulley-3/8 Pitch Metric Bores	5-22
BH	Hubs,Gear,Cluster	12-68	FA,FS	"No Slip" Belts-32DP	5-6	MFMG	No-Slip Sprockets 20DP	5-17
BLC,BLO	Bearings Linear Ceramic Coated	4-12	FA,FD	"No Slip" Pulleys-32DP	5-7	MFRG	No-Slip Sprockets .1475	5-13
BP,BQ,BU	Blanks-Gear,Pin Hub,Hubless	12-53	FER	Ferulles-No-Slide Belts	5-5	MGB3	Gear Boxes-Servomechanisms	11-6
BS	Ball Screws	3-16 - 3-20	FL	Flange,Lead Screw	3-13	MGP1 to MGP4	Pulleys-Geared, "No-Slip"	5-7
C1	Collars-Precision	6-18	FLA,FLS	"No Slip" Belts-20DP	5-14	MHS1 to MHS12	Gears-Spur,Hubless	12-54 to 12-66
C2-15	Set Screws-Slotted Head	8-7	FLG,FLH	"No Slip" Pulleys-20DP	5-15	MHU1 to MHU5	Hubs-Gear	12-68
CN,CO	Gears-Cluster	12-35	FMA,FMS	"No Slip" Belts-20DP-Twin Core	5-16	MHU6 to MHU9	Hubs-Gear & Dial	12-67
CR	Keys-Woodruff	8-24	FMG,FMH	"No Slip" Sprockets-20DP	5-17	MMS1 to MMS4	Sprockets	5-42
CS-1 to -36	"No Mar" Set Screws	8-6	FRA,FRS	"No Slip" Belts-.1475CP-Twin Core	5-12	MPA	Linear Bearing Recirculating Ball - Adjustable	4-9
CS-40 to -50	Socket Head Keys & Sets	10-3	FRG,FRH	Sprockets-.1475CP	5-13			
CS-51 to -67	"Silver Grip" Set Screws	8-5	F-SK	Splice Kit	5-5			
CS-85 to -99	Brass Tip Set Screws	8-7	G,N,R	Kits-Breadboard-1/4 Shaft	10-3			
D1	Couplings-Sleeve	7-12	G1 to G83	Gears-Spur,Pin Hub Index	12-4			
D2 to D14	Pins-Dowel-Slip Fit	8-14	H1 to H60	Gears-Spur,Split Hub Index	12-4			
D15 to D22	Pins-Dowel, Hardened-Press Fit	8-16	J1 to J28	Gears-Spur, Hubless Index	12-4			
D25 to D32	Pins-Dowel, Hardened-Press Fit	8-16	K1-1 to K1-14	Hubs-Gear & Dial-Pin Type	12-67			
D33	Washers-Curved	8-9	K1-50 to K1-52A	Hubs - 5/16 to 1/2 Bore - Pin Type	12-68			

CATALOG SERIES INDEX

If a Part Number is known, this index will assist in identifying and locating the part in the Catalog.

CATALOG SERIES	DESCRIPTION	SECTION PAGE	CATALOG SERIES	DESCRIPTION	SECTION PAGE	CATALOG SERIES	DESCRIPTION	SECTION PAGE
MPFL & MPFLO	Metric Linear Bearing-Self-Aligning	4-10	PLA	Linear Bearings Engineered Plastic - Adjustable	4-11	32HT	Spur Gears 32 pitch	12-10
MPL	Linear Bearing Recirculating Ball - Closed	4-9	PLC	Linear Bearings Engineered Plastic - Closed	4-11	TE	Belt Tensioner	5-3
MPL-XRF	Linear Bearing Flanged - Round	4-7	PLO	Linear Bearings Engineered Plastic - Open	4-11	T14	Coupling & Slip Clutch	7-6
MPL-XSF	Linear Bearing Flanged - Square	4-7	PLS	Linear Bearings Instrument Series	4-8	T15	Coupling-Wafer Spring	7-8
MPLA	Linear Bearings Engineered Plastic - Adjustable	4-11	PL-XRF	Linear Bearing Flanged - Round	4-7	T16	Coupling-Universal Lateral	7-10
MPLC	Linear Bearings Engineered Plastic - Closed	4-11	PL-XSF	Linear Bearing Flanged - Square	4-7	T17	Clutch-Continuous Slip	7-4
MPL0	Linear Bearings Engineered Plastic - Open	4-11	PNB1 to PNB6	Rails	2-9	T18	Coupling-Continuous Slip	7-5
MPO	Linear Bearings Recirculating Ball - Shaft Support Rails	4-9	PNBT-A	Aluminum Crossed Roller Slides	2-6	T21-T24	Coupling-Flexible "K" Type	7-14
MPSR	Shaft Support Rails	4-4	PNBT	Steel Crossed Roller Slides	2-7	T22	Coupling-Flexible-Zero Backlash	7-13
MPSR-X-PD	Shaft Support Rails Predrilled	4-5	PRB	Crossed Roller Slides	2-8	T25	Slip Clutch - Adjustable	7-5
MR	Bore Reducers, Inch to Metric	7-14	PS	Lead Screws (PS Style)	3-5	U1 to U4	Speed Reducers- Sizes 10,11,18	11-1 & 11-2
MRR1 & MRR2	Rings-Retaining,Internal& External	8-11	PSR	Shaft Support Rails	4-4	U7,U8	Gear Heads-Sizes 11,18	11-3
MRR3	Rings-Retaining,Plain ("E Ring")	8-11	PSR-X-PD	Shaft Support Rails - Predrilled	4-5	W3	Hand Cranks	8-25
MS10	Universal Bearing Housing	3-14	PTO-A	Timing Belt Pulleys-.080 Pitch	5-26 & 5-27	Y9	Screws-Captive	8-9
MSA	Housing/Pillow Block-Linear Bearing - Adjustable	4-14	PTO-C	Timing Belt Pulleys-.0816 Pitch	5-28 & 5-29	Y11	Set Screws-Socket Head	8-7
MSB1 & MSB3	Screws-Shoulder, Slotted Head	8-2	PTO-D	Timing Belt Pulleys-1/5 Pitch	5-30 to 5-32	Z1 to Z5	Retaining Rings	8-10 & 8-11
MSB2 & MSB4	Screws-Shoulder, Socket Head	8-3	PTO-F	Timing Belt Pulleys-3mm	5-34 & 5-35	2040 to 2065	Studs-DbL Threaded	6-21
MSB7 & MSB8	Screws - Shoulder, Phillips Head	8-4	PTO-G	Timing Belt Pulleys-5mm	5-36 & 5-37	2100 to 2106	Studs-Threaded, Swivel	8-18
MSC	Housing/Pillow Block-Linear Bearing - Closed	4-14	PTO-J	Timing Belt Pulleys-3/8 Pitch	5-33	3140 to 3145	Nuts-Knurled,Swivel	8-18
MSC1	Collars-Set Screw	6-18	PV	Lead Screw - Antbacklash Nut	3-8	3150 to 3156	Washers-Precision	8-9
MSG3 to MSG34	Gears-Spur,Pin Hub	12-54 to 12-66	PZ	Lead Screw - Antbacklash Nut	3-6	3160 to 3176	Washers-Swivel	8-18
MSG35 - MSG50	Gears-Spur,Split Hub	12-54 to 12-66	Q1 to Q12	Gears-Worm & Worm Wheel	12-46 to 12-48	4010 to 4094	Screws-Thumb,Knurled	8-17
MSH1 to MSH7	Shafting-Ground,Precut & Long Lengths	6-24	Q13 to Q20	Gears-Worm Wheel- Anti-Backlash	12-47 to 12-49	4310 to 4465	Screws-Shoulder 303 S.S.	8-2 & 8-4
MSHA	Metric Shaft Support Blocks/Hangers	4-6	R	Bore Reducers, Inch to Inch	7-14	4510 to 4665	Screws-Shoulder 416 S.S.	8-2 & 8-4
MSO	Housing/Pillow Block-Linear Bearing - Open	4-14	R3	Clutch-Slip Assembly	7-6	4710 to 4854	Screws-Shoulder, Phillips Head	8-4
MSP1 to MSP6	Spacers-Shaft, Shim	6-16 & 6-17	R1,R2,R5,R6	Hangers-Shaft	6-15			
MSR1	Reducers-Speed Miniature	11-1	RD	Rubber Covered Drive Rollers	4-15			
MSR2 & MSR3	Reducers-Speed Miniature	11-2	RS	Rubber Cover Idler Rollers	4-15			
MSS2	Set Screws-"No Mar",Socket Type	8-6	RW1 to RW4	Shaft Mounted Clutches	7-4			
MSS3	Set Screws-"Silver Grip",Socket Type	8-5	RX1 to RX4	Flange Mounted-Power On Brakes	7-3			
MSS4	Set Screws-Cup Point,Socket Type	8-7	RY5 to RY8	Flange Mounted-Power Off Brakes	7-3			
MPFL	Metric Linear Bearing-Self Aligning	4-10	S1,S3,S4	Hangers-Component Mounting	6-26			
MT	Coupling-Flexible Zero Backlash	7-13	S5,S8	Mounting Accessories-Linear Bearings	4-13			
MTN1	Nuts,Thumb,Knurled	8-18	S7	Hangers-Shaft	4-6			
MTS1	Screws-Thumb,Knurled	8-18	S10 & S12	Bearing Housing	3-14			
MUJ1	Universal Lateral	7-10	SCA	Accessories — Handles, Hinges, Door Latch, Roller, Slide Track, Panel Gasket	9-9 to 9-11			
MUJ2 to MUJ4	Universal Joints	7-15	SCB	Angle Brackets	9-5			
N1 to N3	Gears-Miter & Bevel	12-50 to 12-51	SCB	Corner - Braces	9-7			
N1-AB to N3-AB	Gears-Miter-Anti-Backlash	12-51	SCB1	Panel Mounting Angle	9-6			
N4,N5	Couplings-Multi-Jaw	7-11	SCE	Leveling Plates, Casters	9-10			
P1-21 to P1-27B	Cam Follower - Ball or Bronze	6-13	SCH	Fastening Hardware	9-7 to 9-9			
P2 to P70	Gears-Spur,Anti-Backlash	12-36 to 12-44	SCX	Corner - Brackets	9-6			
P101 to P2201	Positioners with Micrometers	2-12	SEB	Extrusions				
PA,PL,PO	Linear Bearings-Closed, Adjustable, Open	4-9	SEB	Ball Slide Guide	2-10			
PB	Ball Slides	2-4	SHA	Shaft Support Blocks/Hangers	4-6			
PBC	Ball Slide Table (Positioning Stage)	1-13	SP	Shim Pack	3-4			
PBE	Economy Ball Slides	2-5	SX	Aluminum Extrusions	9-3 & 9-4			
PE3 to PE16	Rod Ends	6-12	T1	Couplings-Bellows	7-9			
PE12	Spherical Bearings	6-13	T7,T8	Couplings-Oldham,Miniature	7-11			
PFL	Linear Bearings-Self Aligning	4-10	T9,T10	Couplings-Zero Adjustable	7-9			
PFLO	Linear Bearings - Recirculating	4-10	T11,T12	Coupling-Flexible	7-10			
PK	Lead Screw - Antbacklash Nut	3-7	T13E	Coupling 'Spider'	7-7			
			16T	Spur Gears 16 pitch	12-5			
			24T	Spur Gears 24 pitch	12-8			
			32T	Spur Gears 32 pitch	12-11			

PIC DESIGN WORLDWIDE SALES

PIC DESIGN maintains a Worldwide network of Sales Representatives, Agents and Authorized Distributors who stand ready to assist you in your application of standard catalog products or to help you with your modified or special build to print designs. Contact us for the sales help nearest to you or visit our website for the complete listing.

Phone 203-758-8272
800-243-6125
Fax 203-758-8271
Email info@pic-design.com
Website www.pic-design.com



AUTHORIZED PIC DESIGN DISTRIBUTORS

Don't be misled by companies that say they can provide you with PIC precision components. Unfortunately, there are firms that will take your order and substitute parts of questionable origin. Here at PIC Design, we feel that in the over 50 years we've been in business, many design engineers and the companies they work for have gained confidence in PIC. They know PIC as the original company to provide precision mechanical components of the highest quality. When they specify PIC Design, they expect and deserve to get products supplied by PIC Design. For the name of the authorized distributor near you, contact us.

TERMS AND CONDITIONS

Payment Terms:

U.S.A. — Net 30 days. Shipment F.O.B. Middlebury, Connecticut. All shipments are insured.

Worldwide — Terms vary from region to region. Check with the local PIC representative for your area.

Prices:

To secure current prices in the quantities you require, contact PIC Design or your nearest PIC representative. All of our standard catalog products have price and delivery information available in the e-commerce section of our website at www.pic-design.com. In addition, orders can be placed using major credit cards or with prior arrangements — open account.

Technical Information:

The technical information in this catalog supersedes all previous catalog information and is subject to change without notice. PIC Design maintains a complete up to date catalog on our website at www.pic-design.com. Beyond PDF pages of this catalog we have an interactive version with design aids and wizards to help the design process. We also have a complete library of 3D/2D CAD drawings of every PIC component in all the standard formats.

Credit:

Until satisfactory credit has been established we reserve the right to ship C.O.D.

Minimum Order:

PIC minimum order billing is \$50.00

Method of Shipping:

PIC Design has daily scheduled UPS (all methods) and FedEx (small packages) pick up. However, we have on call almost all other carriers.

Shortages:

Claims for shortages must be made within 10 days of receipt of material.

Returns and Exchanges:

Request for returns of standard PIC catalog products must be submitted for approval within 15 days of receipt by customer. An authorized return number must be secured from PIC prior to return of material. All unauthorized returns will be shipped back to the customer at customer's expense.

PIC will inspect authorized return material and, if accepted, will advise customer of charges for handling, inspection and restocking.

No returns will be authorized or credit allowed for used or non-standard items, modified catalog items or catalog items made to customer order in production runs.

Cancellations:

In-process orders, which are terminated by the customer prior to delivery, are subject to cancellation charges at the discretion of PIC.

Telephone, FAX:

Many of our customers use the telephone and FAX to speed their orders on the way. We provide full service to accept such orders; however, errors in transmission are the customer's responsibility. All confirming formal orders must be marked "CONFIRMING" or the cost incurred in duplicate shipments will be the customer's responsibility.

Note:

For detailed terms and conditions, please contact PIC Design or review them on our website at www.pic-design.com.

Precision Industrial Components, LLC
86 Benson Road, P.O. Box 1004
Middlebury, CT 06762-1004

Telephone: (800) 243-6125
(203) 758-8272

FAX: (203) 758-8271.

E-Mail: info@pic-design.com

Hours: 8:00 am to 5:00 pm Eastern Time.

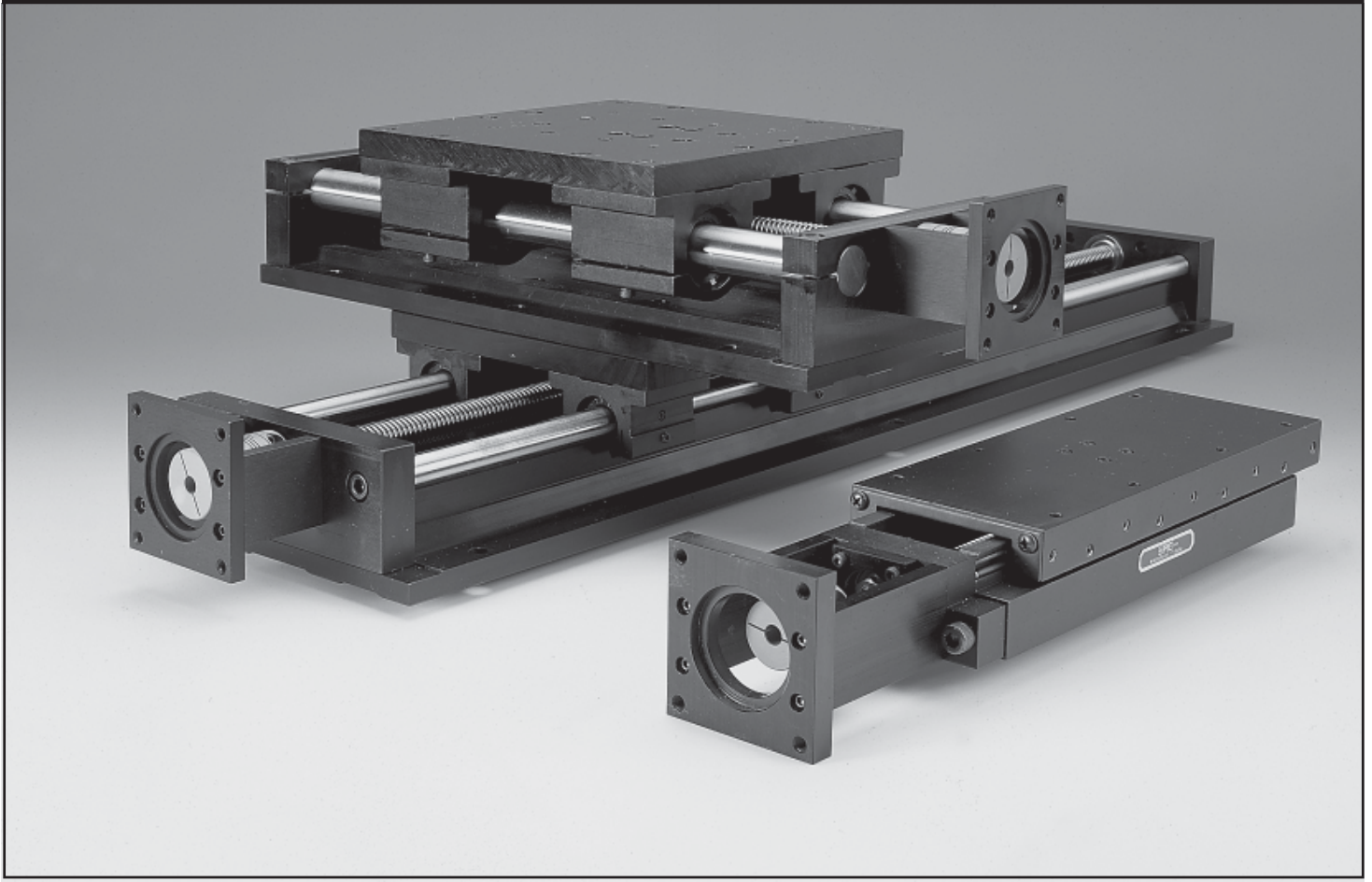

PIC now offers a comprehensive line of linear motion systems.

Single sourcing eliminates the need for extensive, expensive component and system design and time consuming searches through different manufacturers' catalogs for all required designs and sizes.

The first few pages offer a guide to linear motion calculations, for determining effective loads, life of linear bearings, and shaft deflections. These pages are not meant to replace the thinking of an engineer but rather to assist.

System 3 is made up of our standard components found in section 4 of this catalog. This popular configuration is made up of two linear bearings mounted in housings, with a shaft and shaft support rail.

System 9 is available with or without bellows covers. This is a modular pre-assembled precision product, with 4 linear bearings mounted in housings with two parallel shafts mounted to a base plate, with a table top, lead screw and coupling. The key to this unit is standard one-size shafting, which allows for quick delivery at a discounted price. System 9 is ideal for vertical applications. The optional protective Bellows Cover is made of polyurethane coated nylon. These covers protect the shafting and lead screw from damage-causing debris.

System 10 is available with or without bellows covers. It is similar to system 9, but the shafts are fully supported by a one piece integral rail. As with system 9 the one size shafting allows for quick delivery at a discounted price. System 10 is ideal for applications that require greater travel.

Positioning Stages: PIC's industrial grade tables provide solutions for indexing where the strict requirements of scientific stages are not needed. Mounting holes in top and base are located to easily allow two stages to be configured as an X-Y positioner. Ready to hook up to your standard NEMA 23 motor.

LINEAR MOTION SYSTEMS

STEP 1

CALCULATION OF SYSTEM LOADING AND BEARING SELECTION

LOAD CALCULATION

The main factors involved in the selection of bearing material and size are the load on a single bearing and the total travel life required. The load on a single bearing varies with the position of the center of gravity on the table top or carriage. To calculate the load on a single bearing:

1. For system 3, use load calculation diagram 1 for vertical applications, and load calculation diagram 2 for horizontal applications.
2. For other frequently used system configurations, use load calculation diagram 3 for horizontal axis, load calculation diagram 4 for vertical axis, and load calculation diagram 5 for vertical lateral axes.

LOAD CALCULATION DIAGRAMS

DIAGRAM 1

$$P_1 = P_2 = \frac{t_1}{t_0} W$$

DIAGRAM 2

$$P_1 = \frac{t_2}{t_1 + t_2} W$$

$$P_2 = \frac{t_1}{t_1 + t_2} W$$

DIAGRAM 3

$$P_1 = \frac{1}{4} W + \frac{X}{2X} W + \frac{H}{2Y} W$$

$$P_2 = \frac{1}{4} W + \frac{X}{2X} W - \frac{H}{2Y} W$$

$$P_3 = \frac{1}{4} W + \frac{X}{2X} W + \frac{H}{2Y} W$$

$$P_4 = \frac{1}{4} W + \frac{X}{2X} W - \frac{H}{2Y} W$$

DIAGRAM 4

$$P_1 = P_2 = P_3 = P_4 = \frac{t}{2X} W$$

$$P_{1s} = P_{2s} = P_{3s} = P_{4s} = \frac{H}{2X} W$$

DIAGRAM 5

$$P_1 = P_2 = P_3 = P_4 = \frac{t}{2Y} W$$

$$P_{1s} = P_{2s} = \frac{1}{4} W - \frac{X}{2X} W$$

$$P_{3s} = P_{4s} = \frac{1}{4} W + \frac{X}{2X} W$$

P = FORCE ON BEARINGS
W = WEIGHT ON SYSTEM



BEARING SELECTION

Two types of bearings, self-aligning recirculating ball bearings and engineered plastic bearings, are available from PIC for use in linear motion systems. Both types are available in inch or metric sizes, and closed or open styles.

SELF-ALIGNING BEARINGS

The formulas and tables listed below will enable the designer to select the proper self-aligning bearings to meet the required life.

Basic Dynamic Load Rating and Life Expectancy

The basic dynamic load rating of a self-aligning bearing is the load which allows a rating life of 2,000,000 inches or 50,000 meters of travel, without change in magnitude or direction. The rating life of a bearing for a particular application can be calculated from the following equations:

For inch calculations,

$$L = \left[\frac{f_h}{f_w} \cdot \frac{C}{P} \right]^3 \cdot 2 \cdot 10^6$$

For metric calculations,

$$L(\text{km}) = \left[\frac{f_h}{f_w} \cdot \frac{C}{P} \right]^3 \cdot 50$$

With:

L = rating life in inches for inch calculations, in kilometers for metric calculations

f_h = hardness factor (1.0); shafts are 60-65 HRC

f_w = load coefficient (refer to table 1)

C = basic design load rating in pounds for inch calculations, in Newtons for metric calculations (refer to table 2 or 3)

P = force in pounds for inch calculations, force in Newtons for metric calculations, determined from load calculation diagrams 1 through 5, as applicable

Rating life in hours can be calculated from the travel distance per unit of time, as follows:

$$L_h = \frac{L}{2 \cdot L_s \cdot n_1 \cdot 60}$$

With:

L_h = rating life in hours

L_s = stroke length in inches for inch calculations, in meters for metric calculations

n_1 = rating in cycles per minute

To calculate the basic dynamic load rating, use the following formulas:

For distances in inches,

$$C = \sqrt[3]{\frac{L}{2 \cdot 10^6}} \cdot \frac{f_w}{f_h} \cdot P$$

For distances in kilometers,

$$C = \sqrt[3]{\frac{L}{1 \cdot 50}} \cdot \frac{f_w}{f_h} \cdot P$$

Example of Calculations using standard PIC components

Expected Life: 20,000 hours

Number Of Bearings: 4

Weight On Carriage: 175 lb

Stroke Distance: 24 inches

Traveling Speed: 1000 in. / min

Cycle: 2 x 24 inches

Shaft: A10L series

From the life expectancy in hours formula, the life expectancy in traveling distance is:

$$L_h = \frac{L}{2 \cdot L_s \cdot n_1 \cdot 60}$$

$$L = L_h \cdot 2 \cdot L_s \cdot n_1 \cdot 60$$

$$L = 20,000 \cdot 2 \cdot 24 \cdot \frac{1000}{2 \cdot 24} \cdot 60$$

$$L = 1.20 \times 10^9 \text{ inches}$$

From the dynamic load rating formula:

$$C = \sqrt[3]{\frac{L}{2 \cdot 10^6}} \cdot \frac{f_w}{f_h} \cdot P$$

$$C = \sqrt[3]{\frac{1.2 \cdot 10^9}{2 \cdot 10^6}} \cdot \frac{1.5}{1.0} \cdot \frac{175}{4}$$

$$C = 553 \text{ lb}$$

The assumption is that the 175 pound load is distributed evenly between bearings; therefore, using diagram 3 with 1-inch with 1-inch diameter bearings having a load capacity of 850 pounds is selected.

Table 1. Load Coefficient

Operating Conditions	f_w
Operation at low speed (50 ft/min or 15 m/min or less) without impulsive shock from outside	1 - 1.5
Operation at intermediate speed (200 ft/min or 60 m/min or less) without impulsive shock	1.5 - 2.0
Operation at high speed (over 200 ft/min or 60 m/min) with impulsive shock from outside	2.0 - 3.5

Table 2. C Dynamic Load Rating of Inch Bearings

Shaft Diameter (inch)	Rating (lb)	PIC Part No.	
		Closed	Open
1/4	60	PFL-4	—
3/8	95	PFL-6	—
1/2	230	PFL-8	PFL0-8
5/8	400	PFL-10	PFL0-10
3/4	470	PFL-12	PFL0-12
1	850	PFL-16	PFL0-16
1 1/4	1230	PFL-20	PFL0-20
1 1/2	1480	PFL-24	PFL0-24

Table 3. C Dynamic Load Rating of Metric Bearings

Shaft Diameter (mm)	Rating (Newtons)	PIC Part No.
CLOSED TYPE		
12	650	MPFL-12
16	800	MPFL-16
20	1500	MPFL-20
25	2500	MPFL-25
30	3200	MPFL-30
40	5550	MPFL-40
OPEN TYPE		
12	750	MPFL0-12
16	920	MPFL0-16
20	1560	MPFL0-20
25	2600	MPFL0-25
30	3330	MPFL0-30
40	5740	MPFL0-40

ENGINEERED PLASTIC LINEAR BEARINGS

PIC self-lubricating plastic bearings are maintenance free, run quietly, are not subject to catastrophic failure, do not gall or brinell the mating shaft, and can run on "soft" non-corrosive 303 stainless steel shafting. These bearings are also capable of operation in hostile environments and are interchangeable with PIC self-aligning, recirculating bearings.

Bearing PV Rating

The performance capabilities of engineered plastic linear bearings are defined by the PV rating of the bearings, where P is the pressure in pounds per square inch on the projected bearing area, and V is the velocity in feet per minute of the wear surface. Maximum PV for continuous operation is 7500 PSI/FPM. To calculate PV for a particular application, divide the total load in pounds on the bearing by the effective area in square inches, and multiply by the average bearing velocity in feet per minute.

Example of Calculation:

Number Of Bearings: 4

Weight On Carriage: 175 lb

Load Per Bearing: $175/4 = 43.75 \text{ lb}$

Traveling Speed: 1000 in./min or 83.33 ft/min

Bearing Selected: PLC-16 (1 in. = ID, 2.25 in. long = L)

$$P = \frac{\text{Load (lb.)}}{\text{ID} \cdot L} = \frac{43.75}{1 \cdot 2.25} = 19.44 \text{ PSI}$$

$$PV = 19.44 \cdot 83.33 = 1620 \text{ PSI/FPM}$$

LINEAR MOTION SYSTEMS



DETERMINATION OF SHAFT DEFLECTION

Once the appropriate bearing has been selected to fulfill the load requirements of the application, the shaft deflection must be determined. Dimensions and tolerances of PIC shafts are listed in table 4. The required shaft diameter is dictated by the ID of the selected bearing, and the deflection can be determined from table 5 or 6 for inch or metric systems, respectively.

Table 4. Shaft Diameters and Tolerances

Diameter (inch)	PIC Series	Tolerance (inch)
1/4	A10L-4	0.2495 / 0.2490
3/8	A10L-6	0.3745 / 0.3740
1/2	A10L-8	0.4995 / 0.4990
5/8	A10L-10	0.6245 / 0.6240
3/4	A10L-12	0.7495 / 0.7490
1	A10L-16	0.9995 / 0.9990
1 1/4	A10L-20	1.2495 / 1.2490
1 1/2	A10L-24	1.4994 / 1.4989

Table 5. Shaft Deflection Table (Inch Systems). Deflection Per Pound At Center Of Fixed Supporting Shaft.

Shaft Diameter (inches)	Length Of Unsupported Section (inches)												
	4	6	8	10	12	16	20	24	30	36	42	48	72
1/4	5.85 x 10 ⁻⁵	1.98 x 10 ⁻⁴	4.68 x 10 ⁻⁴	9.15 x 10 ⁻⁴	1.58 x 10 ⁻³	3.75 x 10 ⁻³	7.32 x 10 ⁻³	1.26 x 10 ⁻²	2.5 x 10 ⁻²				
3/8	1.20 x 10 ⁻⁵	4.05 x 10 ⁻⁵	9.63 x 10 ⁻⁵	1.79 x 10 ⁻⁴	3.25 x 10 ⁻⁴	7.68 x 10 ⁻⁴	1.43 x 10 ⁻³	2.60 x 10 ⁻³	4.83 x 10 ⁻³	8.33 x 10 ⁻³	1.32 x 10 ⁻²	1.98 x 10 ⁻²	
1/2	3.63 x 10 ⁻⁶	1.23 x 10 ⁻⁵	2.90 x 10 ⁻⁵	5.68 x 10 ⁻⁵	9.83 x 10 ⁻⁵	2.33 x 10 ⁻⁴	4.50 x 10 ⁻⁴	7.85 x 10 ⁻⁴	1.53 x 10 ⁻³	2.65 x 10 ⁻³	4.20 x 10 ⁻³	6.28 x 10 ⁻³	2.12 x 10 ⁻²
3/4	7.15 x 10 ⁻⁷	2.42 x 10 ⁻⁶	5.73 x 10 ⁻⁶	1.12 x 10 ⁻⁵	1.94 x 10 ⁻⁵	4.58 x 10 ⁻⁵	8.95 x 10 ⁻⁵	1.55 x 10 ⁻⁴	3.02 x 10 ⁻⁴	5.23 x 10 ⁻⁴	8.30 x 10 ⁻⁴	1.24 x 10 ⁻³	4.18 x 10 ⁻³
1	2.25 x 10 ⁻⁷	7.70 x 10 ⁻⁷	1.76 x 10 ⁻⁶	3.55 x 10 ⁻⁶	6.15 x 10 ⁻⁶	1.46 x 10 ⁻⁵	2.85 x 10 ⁻⁵	4.93 x 10 ⁻⁵	9.63 x 10 ⁻⁵	1.66 x 10 ⁻⁴	2.63 x 10 ⁻⁴	3.93 x 10 ⁻⁴	1.33 x 10 ⁻³
1 1/4	9.30 x 10 ⁻⁸	3.13 x 10 ⁻⁷	7.45 x 10 ⁻⁷	1.45 x 10 ⁻⁶	2.50 x 10 ⁻⁶	5.95 x 10 ⁻⁶	1.16 x 10 ⁻⁵	2.01 x 10 ⁻⁵	3.93 x 10 ⁻⁵	6.78 x 10 ⁻⁵	1.08 x 10 ⁻⁴	1.61 x 10 ⁻⁴	5.43 x 10 ⁻⁴
1 1/2	4.48 x 10 ⁻⁸	1.51 x 10 ⁻⁷	3.58 x 10 ⁻⁷	7.00 x 10 ⁻⁷	1.21 x 10 ⁻⁶	2.88 x 10 ⁻⁶	5.60 x 10 ⁻⁶	9.68 x 10 ⁻⁶	1.89 x 10 ⁻⁵	3.28 x 10 ⁻⁵	5.18 x 10 ⁻⁵	7.75 x 10 ⁻⁵	2.58 x 10 ⁻⁴
2	1.42 x 10 ⁻⁸	4.78 x 10 ⁻⁸	1.13 x 10 ⁻⁷	2.21 x 10 ⁻⁷	3.83 x 10 ⁻⁷	9.05 x 10 ⁻⁷	1.77 x 10 ⁻⁶	3.05 x 10 ⁻⁶	5.98 x 10 ⁻⁶	1.03 x 10 ⁻⁵	1.64 x 10 ⁻⁵	2.45 x 10 ⁻⁵	8.25 x 10 ⁻⁵

Note:

Deflections listed above are based on system being fixed at both ends, with load in center of span.

Using the formula:

$$\text{Deflection} = \frac{W_s L^3}{192EI}$$

W_s = Load on shaft

L = Length

E = Modulus of elasticity

I = Moment of inertia of cross section

Example:

Shaft: 1/4 in. diameter

Load: 8 pounds

Length: 10 inches

Multiplier

(From Table 5): 9.15 x 10⁻⁴ inches/pound

$$\text{Deflection} = \frac{9.15 \times 10^{-4} \text{ inches}}{\text{pound}} \times 8 \text{ pounds} = .0073 \text{ inches}$$

Note:

If deflection is greater than 1/2° suggest using shaft supports and open bearings

Table 6. Shaft Deflection Table (Metric Systems). Deflection Per kgf At Center Of Fixed Supporting Shaft.

Shaft Diameter (mm)	Length Of Unsupported Section (mm)							
	125	250	500	750	1000	1250	1500	2000
12	4.75 x 10 ⁻⁴	3.80 x 10 ⁻³	3.04 x 10 ⁻²	1.02 x 10 ⁻¹	2.4 x 10 ⁻¹	4.75 x 10 ⁻¹	8.21 x 10 ⁻¹	1.95
16	1.50 x 10 ⁻⁴	1.20 x 10 ⁻³	9.62 x 10 ⁻³	3.25 x 10 ⁻²	7.7 x 10 ⁻²	1.50 x 10 ⁻¹	2.59 x 10 ⁻¹	6.16 x 10 ⁻¹
20	6.15 x 10 ⁻⁵	4.92 x 10 ⁻⁴	3.94 x 10 ⁻³	1.33 x 10 ⁻²	3.15 x 10 ⁻²	6.15 x 10 ⁻²	1.06 x 10 ⁻¹	2.52 x 10 ⁻¹
25	2.52 x 10 ⁻⁵	2.02 x 10 ⁻⁴	1.62 x 10 ⁻³	5.45 x 10 ⁻³	1.29 x 10 ⁻²	2.52 x 10 ⁻²	4.36 x 10 ⁻²	1.03 x 10 ⁻¹
30	1.21 x 10 ⁻⁵	9.72 x 10 ⁻⁵	7.78 x 10 ⁻⁴	2.63 x 10 ⁻³	6.23 x 10 ⁻³	1.21 x 10 ⁻²	2.10 x 10 ⁻²	4.98 x 10 ⁻²
40	3.84 x 10 ⁻⁶	3.07 x 10 ⁻⁵	2.45 x 10 ⁻⁴	8.30 x 10 ⁻⁴	1.96 x 10 ⁻³	3.84 x 10 ⁻³	6.64 x 10 ⁻³	1.57 x 10 ⁻²

Note:

Deflections listed above are based on system being fixed at both ends, with load in center of span.

Using the formula:

$$\text{Deflection} = \frac{W_s L^3}{192EI}$$

W_s = Load on shaft

L = Length

E = Modulus of elasticity

I = Moment of inertia of cross section

Example:

Shaft: 20 mm diameter

Load: 25 kgf

Length: 1000 mm

Multiplier

(From Table 6): 3.15 x 10⁻² mm/kg

$$\text{Deflection} = \frac{3.15 \times 10^{-2} \text{ mm}}{\text{kgf}} \times 25 \text{ kgf} = 0.7875 \text{ mm}$$

$$\text{Shaft Load} = \frac{\text{Total Load}}{\text{Number of Shafts}}$$

LINEAR MOTION SYSTEMS

USES STANDARD PIC COMPONENTS

User Assembled †

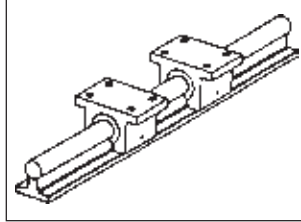

SYSTEM 3

COMPONENT SELECTION SYSTEMS 3 / INCH & METRIC

Bill of Material — Systems 3 / Inch

Shaft Dia. (in)	Bearing			Bearing Housing		Shafting			Shaft Support Rail	
	Type	Part No.	QTY	Part No.	QTY	Type	Part No.	Part No.	QTY *	
1/2	Self-Aligning	PFLO-8	2	S5-13S	2	1060 Steel	A10-8D-**	PSR-8-PD	1	
	Engr. Plastic	PLO-8	2	S5-13		303 Stainless	A11-8D-**			
5/8	Self-Aligning	PFLO-10	2	S5-14S	2	1060 Steel	A10-10D-**	PSR-10-PD	1	
	Engr. Plastic	PLO-10	2	S5-14		303 Stainless	A11-10D-**			
3/4	Self-Aligning	PFLO-12	2	S5-15S	2	1060 Steel	A10-12D-**	PSR-12-PD	1	
	Engr. Plastic	PLO-12	2	S5-15		303 Stainless	A11-12D-**			
1	Self-Aligning	PFLO-16	2	S5-16S	2	1060 Steel	A10-16D-**	PSR-16-PD	1	
	Engr. Plastic	PLO-16	2	S5-16		303 Stainless	A11-16D-**			
1 1/4	Self-Aligning	PFLO-20	2	S5-17S	2	1060 Steel	A10-20D-**	PSR-20-PD	1	
	Engr. Plastic	PLO-20	2	S5-17		303 Stainless	A11-20D-**			
1 1/2	Self-Aligning	PFLO-24	2	S5-18S	2	1060 Steel	A10-24D-**	PSR-24-PD	1	
	Engr. Plastic	PLO-24	2	S5-18		303 Stainless	A11-24D-**			

Bill of Material — Systems 3 / Metric

Shaft Dia. (mm)	Bearing			Bearing Housing		Shafting			Shaft Support Rail	
	Type	Part No.	QTY	Part No.	QTY	Type	Part No.	QTY	Part No.	QTY *
12	Self-Aligning	MPFLO-12	2	MSO-12	2	1060 Steel	MA10-12D-**	1	MPSR-12-PD	1
	Engr. Plastic	MPLO-12	2			303 Stainless	MA11-12D-**			
16	Self-Aligning	MPFLO-16	2	MSO-16	2	1060 Steel	MA10-16D-**	1	MPSR-16-PD	1
	Engr. Plastic	MPLO-16	2			303 Stainless	MA11-16D-**			
20	Self-Aligning	MPFLO-20	2	MSO-20	2	1060 Steel	MA10-20D-**	1	MPSR-20-PD	1
	Engr. Plastic	MPLO-20	2			303 Stainless	MA11-20D-**			
25	Self-Aligning	MPFLO-25	2	MSO-25	2	1060 Steel	MA10-25D-**	1	MPSR-25-PD	1
	Engr. Plastic	MPLO-25	2			303 Stainless	MA11-25D-**			
30	Self-Aligning	MPFLO-30	2	MSO-30	2	1060 Steel	MA10-30D-**	1	MPSR-30-PD	1
	Engr. Plastic	MPLO-30	2			303 Stainless	MA11-30D-**			
40	Self-Aligning	MPFLO-40	2	MSO-40	2	1060 Steel	MA10-40D-**	1	MPSR-40-PD	1
	Engr. Plastic	MPLO-40	2			303 Stainless	MA11-40D-**			

Example

System 3 Bill of Material Example:

System 3, 48 inches long, with self-aligning recirculating bearings would consist of the following:

- 2 PFLO-8 bearings
- 2 S5-13S bearing housings
- 1 A10-8D-48 shaft
- 2 PSR-8-PD shaft support rails

Example — System 3:

48" long, 1/2" shaft with self-aligning recirculating bearings.

Part Number = LS38-48

NOTE: * Quantity of support rail depends on shaft length: each support rail is 24 inches (610 mm) long.

** Length of shaft in inches for inch systems.
Length of shaft in millimeters for metric systems.

† Can be ordered pre-assembled by PIC

TECHNICAL SECTION

System 9 — Economical and Quick Delivery

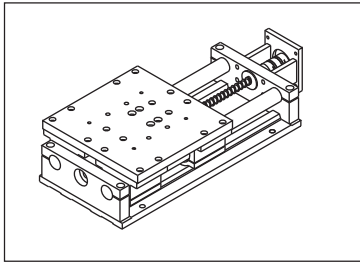

SYSTEM 9

PIC Design has developed a modular pre-assembled precision product. This unit is ideal for vertical applications. It is made with $\frac{3}{4}$ inch suspended shafting with a $\frac{1}{2}$ inch diameter lead screw.

Specifications

- Flatness (No Load):** $\pm .0002$ in./in.
Straightness: $\pm .0002$ in./in.
Repeatability: $\pm .0005$ in.
Positional Accuracy: ± 0.0006 in./in.
Coef. of Friction: .01 recirculating ball linear bearings
 .2 for engineered plastic linear bearings
Break Away Torque Typ.: 10 to 25 inch-ounces
Weight: System 9 with 4 inches of travel = 11.6 pounds
 For longer travels add 0.5 pounds per inch of travel
 (carriage assembly 3.5 pounds)
Material:
 - Aluminum base, carriage and pillow blocks
 - Stainless steel lead screw with engineered plastic nut
 - C1060 hardened & ground shafting & self-aligning recirculating linear ball bearings or 303 stainless steel shafting & engineered plastic bearings
 - Stainless steel radial bearings ABEC 7
 - 17-4 Stainless steel zero backlash coupling
 NEMA 23 for $\frac{1}{4}$ " motor shaft
 NEMA 34 for $\frac{3}{8}$ " motor shaft**Finish:** Aluminum; black anodize

Maximum Loads — Load Centered On Carriage Top (pounds)

Recirculating Ball Linear Bearings

Travel (Inches)	20	16	12	8	4
Loads Static & Dynamic*	190	220	270	350	480

Engineered Plastic Linear Bearings

Travel (Inches)	20	16	12	8	4
Loads Static	190	220	270	350	480
Loads Dynamic**	360	360	360	360	360

Deflection — Load Centered On Carriage Top

Travel (Inches)	20	16	12	8	4
Deflection (Inch/100 lb.)	.013	.008	.005	<.001	<.001

Maximum Moments — Ft. - lbs.

Recirculating Ball Linear Bearing

	Static	Dynamic*
Roll Axis	300	80
Pitch Axis	350	100
Yaw Axis	350	100

Engineered Plastic Linear Bearing

Travel	20	16	12	8	4
Roll Axis Static	110	130	160	200	270
Roll Axis Dynamic	50	50	50	50	50
Pitch Axis Static	480	480	480	480	480
Pitch Axis Dynamic	60	60	60	60	60
Yaw Axis Static	480	480	480	480	480
Yaw Axis Dynamic	60	60	60	60	60

Notes

* Dynamic loads for recirculating ball linear bearings are based on 50 Million inches of life.

** Dynamic loads for engineered plastic linear bearings are based on PV = 16,000 with a V = 100 FPM.

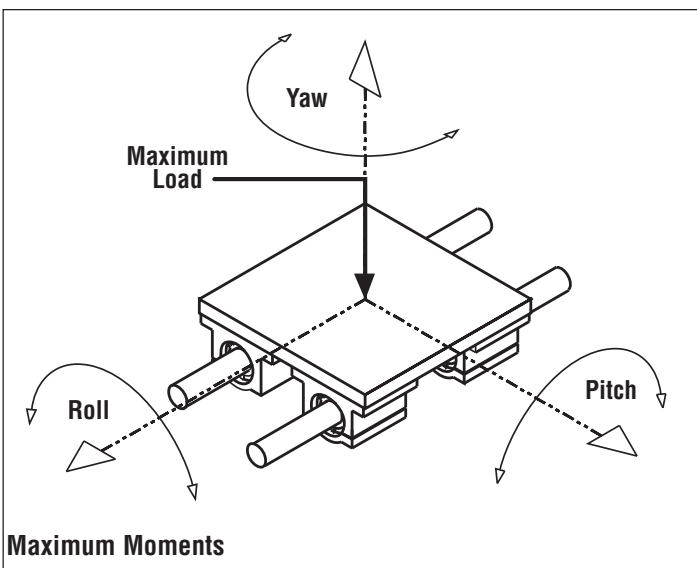

LINEAR MOTION SYSTEMS

System 9 Ordering Code

System Ordering Code

System 9 ordering code is as follows:

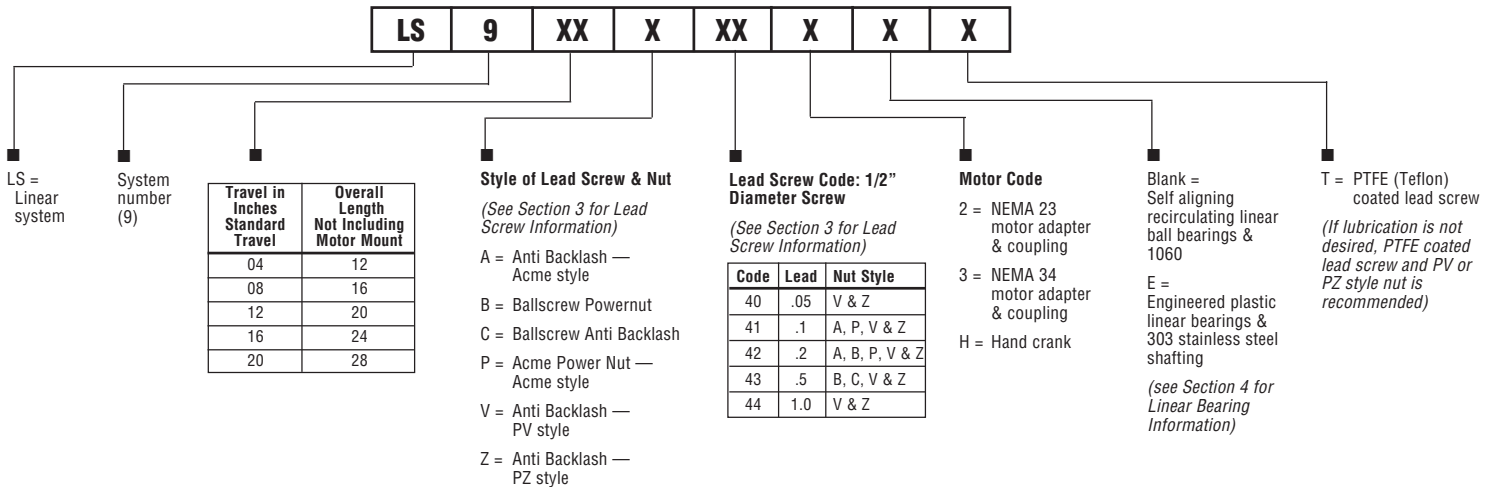

Model LS904 Thru LS920

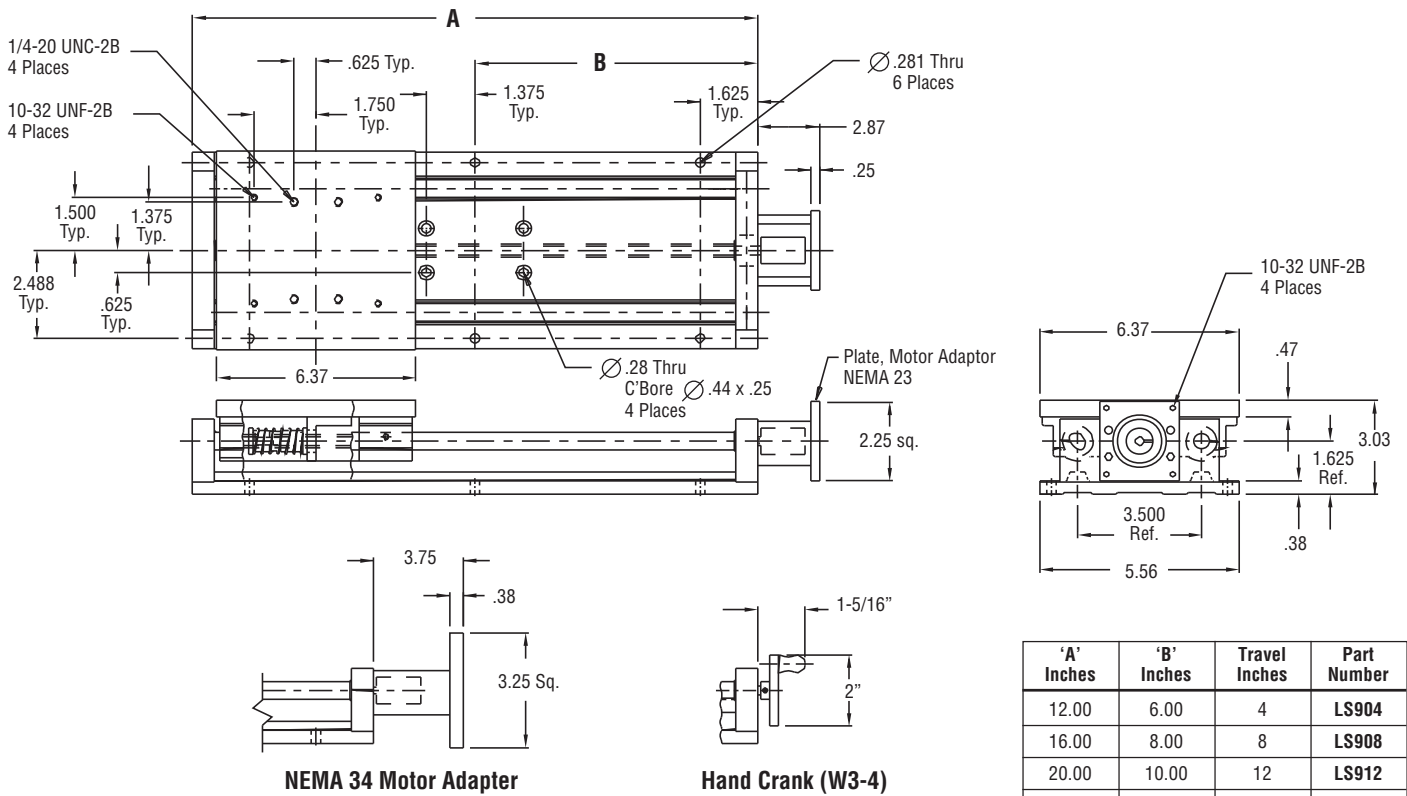

(Shown with NEMA 23 motor adaptor plate. Options: NEMA 34 motor adaptor plate or hand crank)

TECHNICAL SECTION

System 10 — Economical, Quick Delivery & Accuracy

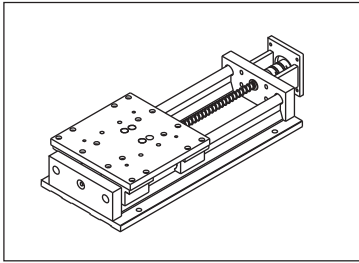

SYSTEM 10

PIC Design has incorporated rail supports in an integral base plate and rail support system. Standardizing on 1/2" diameter shafting and lead screw allows for lower production costs and ease of stocking of the components which transfers to lower prices and quicker deliveries. Travels over 17 inches incorporates two standard base plates without jeopardizing the integrity of the system.

Specifications

- Flatness:** ± .0002 in/in
- Straightness:** ± .0002 in/in
- Positional Repeatability:** ± .0005 in.
- Positional Accuracy:** ± .0006 in/in
- Coefficient of Friction:** .01 recirculating ball linear bearing
.20 for engineered plastic linear bearing
- Break Away Torque Typical:** 10 to 25 inch-ounces
- Weight:** System 10 with 5 inches of travel: 8.1 pounds.
For longer travels add 0.4 pounds per inch of travel.
(Carriage assembly 2.4 pounds)
- Material:**
- Aluminum base, carriage and pillow blocks
 - 303 stainless steel lead screw with engineered plastic nut
 - C1060 hardened & ground shafting & self-aligning recirculating linear ball bearings or 303 stainless steel Shafting & engineered plastic bearings
 - Stainless steel radial bearings ABEC 7
 - 17-4 Stainless steel zero backlash coupling NEMA 23 for 1/4" motor shaft
NEMA 34 for 3/8" motor shaft
- Finish:** Aluminum black anodize
- Loads Maximum:**
- Loads centered on carriage
 - Static 700 pounds
 - Dynamic 300 pounds for recirculating ball (50 million inches of life)
 - Dynamic 240 pounds for engineered plastic (PV = 10,000, V = 100 Fpm)

Maximum Moments

	Recirculating Ball Ft-Lb.	Engineered Plastic Ft-Lb.
Roll Axis — Static	44	44
Dynamic	15	12
Pitch Axis — Static	52	52
Dynamic	17	14
Yaw Axis — Static	110	110
Dynamic	28	22

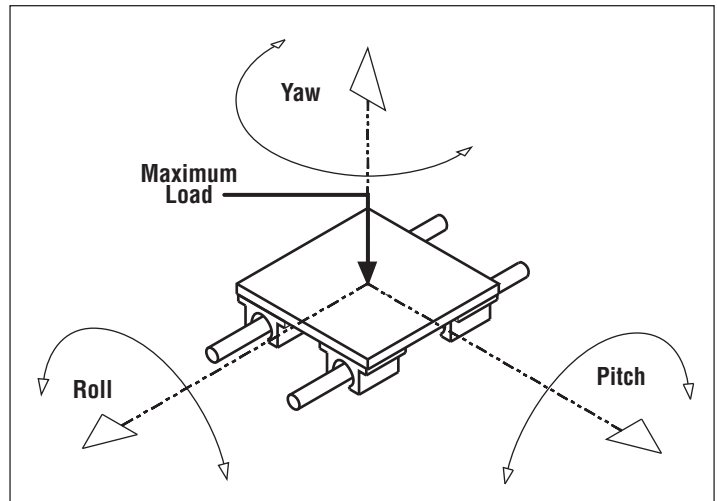

Life With Recirculating Ball Linear Bearings $L = [C/F]^3 (B)$

- L = Normal travel life
- C = Rated dynamic load capacity of carriage
- F = User applied load
- B = 50 million inches of travel

Example: User is using recirculating ball bearing and has a 200 pound load center on carriage top. How many inches of travel can he expect?

$$L = (300/200)^3(50 \text{ million}) = 168 \text{ million inches or about 2660 miles.}$$

Velocity = rpm x lead of lead screw

Example: Determine the velocity of a system with a motor running at 1750 rpm if a lead screw with a one-inch lead is used.

$$\text{Velocity} = 1750 \text{ rpm} \times 1 \text{ inch lead} = 1750 \text{ inches per minute or } 146 \text{ feet per minute.}$$

High lead screw rpm and/or low lead screw leads may require lubrication of the lead screw.

LINEAR MOTION SYSTEMS

System 10 Ordering Code

System Ordering Code

System 10 ordering code is as follows:

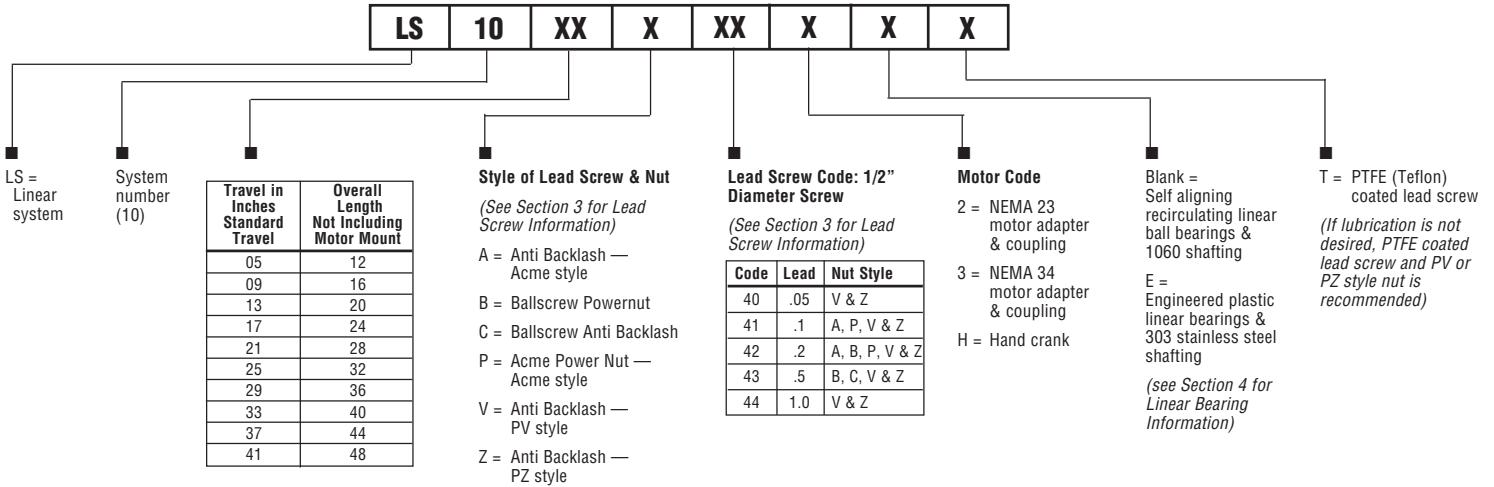

Model LS1021 Thru LS1041 - Two Piece Construction

A Inches	B Inches	C Inches	D Inches	E Inches	F	Travel Inches	Part Number
*28.00	11.98	15.98	6.00	8.00	12	21	LS1021
32.00	15.98	15.98	8.00	8.00	12	25	LS1025
36.00	15.98	19.98	8.00	10.00	12	29	LS1029
40.00	19.98	19.98	10.00	10.00	12	33	LS1033
44.00	19.98	23.98	10.00	12.00	12	37	LS1037
48.00	23.98	23.98	12.00	12.00	12	41	LS1041

Model LS1005 Thru LS1017 - One Piece Construction

A Inches	D Inches	F	Travel Inches	Part Number
12.00	6.00	6	5	LS1005
16.00	8.00	6	9	LS1009
20.00	10.00	6	13	LS1013
24.00	12.00	6	17	LS1017

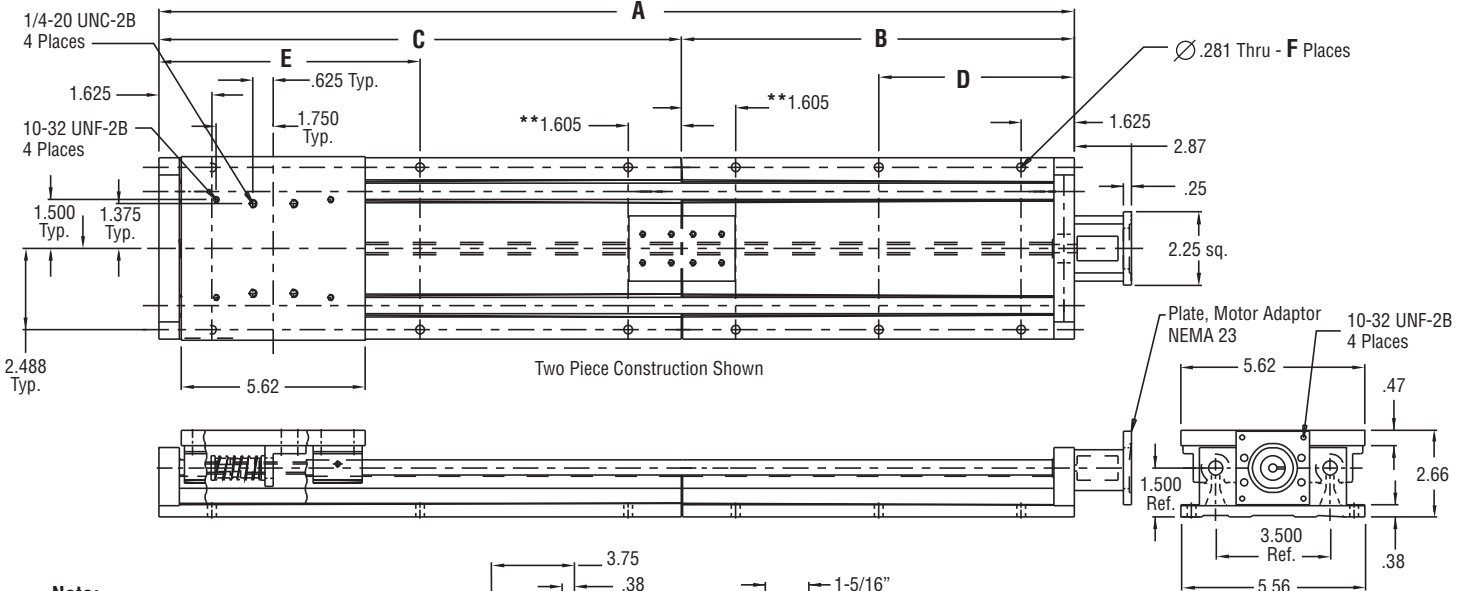

Note:

- * Can be shipped as one piece construction
- ** Used for two piece construction or one piece 21" travel only

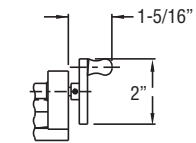
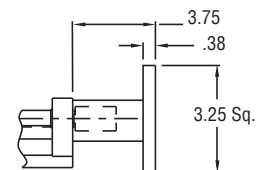

(Shown with NEMA 23 motor adapter plate. Options: NEMA 34 motor adapter plate or hand crank)

LINEAR MOTION SYSTEMS WITH INTEGRAL BELLOWS

Systems 9B and 10B

Systems 9 and 10 are available with a Protective Bellows Cover made of polyurethane-coated nylon. These units have the same load carrying ability as the standard Systems 9 and 10 but are protected from damage-causing debris. The cover is resistant to oil and will operate over a temperature range from — 65° to 250°F.

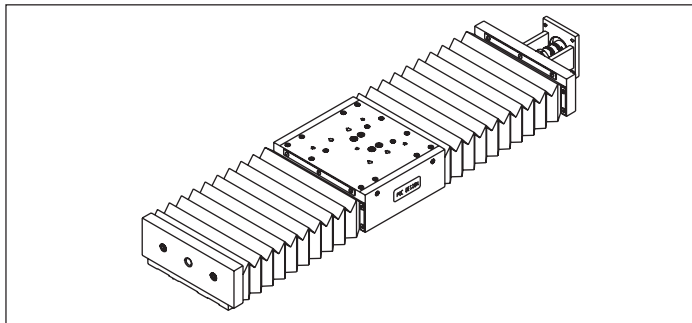
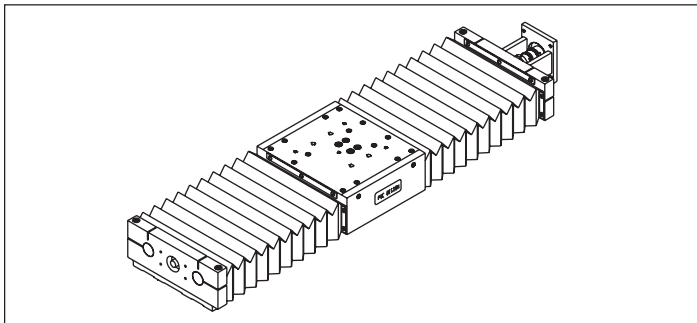

System 9B

System 9B is ideal for vertical applications. It is made with 3/4 inch and end suspended shafting and a 1/2 inch diameter lead screw.

System 10B

System 10B incorporates rail supports that are integral to the base plate and rail.

Specifications

Same as systems without Bellows Covers.

System Ordering Code — System 9B ordering code is as follows:

LS 9 B XX X XX X X X

LS = Linear system

System number (9)

B = Bellows Cover

Code	Travel In Inches	Overall Length Not Including Motor Mount
04	2.86	12
08	6.10	16
12	8.96	20
16	12.20	24
20	15.44	28

Style of Lead Screw & Nut

- A = Anti Backlash — Acme style
- B = Ballscrew Powernut
- C = Ballscrew Anti Backlash Acme style
- P = Acme Power Nut — Acme style
- V = Anti Backlash — PV style
- Z = Anti Backlash — PZ style

Lead Screw Code: 1/2" Diameter Screw

Code	Lead	Nut Style
40	.05	V & Z
41	.1	A, P, V & Z
42	.2	A, B, P, V & Z
43	.5	B, C, V & Z
44	1.0	V & Z

Motor Code

- 2 = NEMA 23 motor adaptor & coupling
- 3 = NEMA 34 motor adaptor & coupling
- H = Hand crank

Blank = Self aligning recirculating linear ball bearings & 1060 shafting

E = Engineered plastic linear bearings & 303 stainless steel shafting

T = PTFE (Teflon) coated lead screw

(If lubrication is not desired, PTFE coated lead screw and PV or PZ style nut is recommended)

Model LS9B04 Thru LS9B20

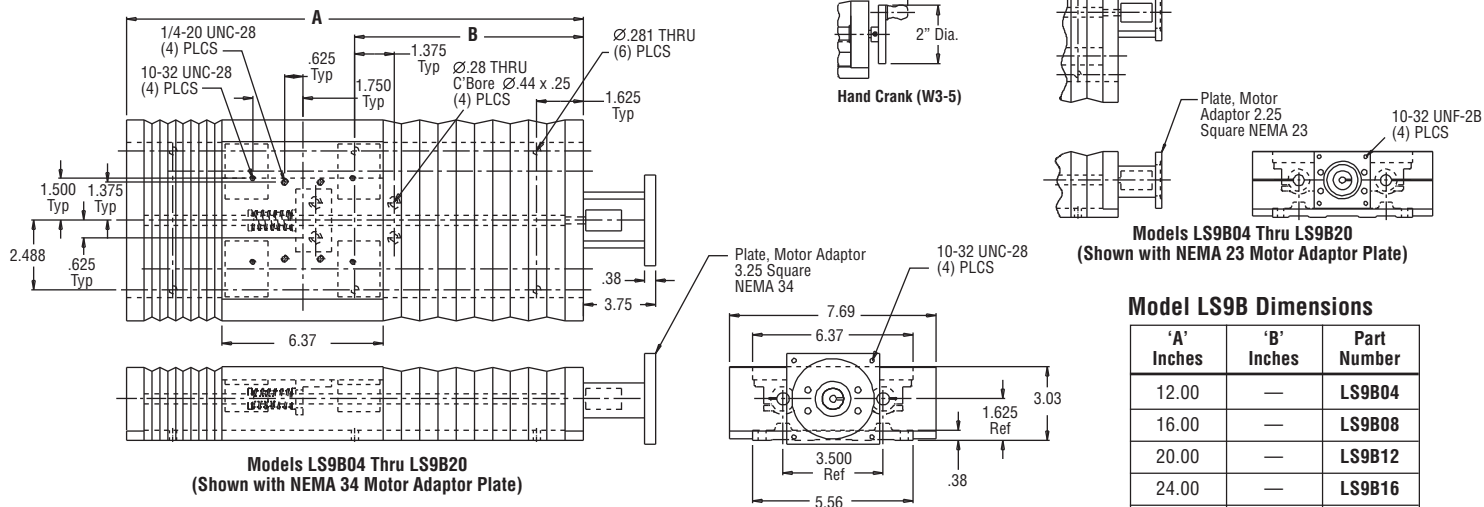

LINEAR MOTION SYSTEMS WITH INTEGRAL BELLOWS

Systems 9B and 10B

System Ordering Code — System 10B ordering code is as follows:

LS	10	B	XX	X	XX	X	X	X
-----------	-----------	----------	-----------	----------	-----------	----------	----------	----------

LS = Linear system

System number (10)

B = Bellows Cover

Code	Travel In Inches	Overall Length Not Including Motor Mount
05	3.48	12
09	6.34	16
13	9.20	20
17	12.06	24
21	14.92	28
25	17.78	32
29	20.64	36
33	23.88	40
37	26.74	44
41	29.60	48

Style of Lead Screw & Nut

A = Anti Backlash — Acme style

B = Ball Screw Power Nut

C = Ball Screw Anti Backlash Nut

P = Acme Power Nut — Acme style

V = Anti Backlash — PV style

Z = Anti Backlash — PZ style

Lead Screw Code: 1/2" Diameter Screw

Code	Lead	Nut Style
40	.05	V & Z
41	.1	A, P, V & Z
42	.2	A, B, P, V & Z
43	.5	B, C, V & Z
44	1.0	V & Z

Motor Code

2 = NEMA 23 motor adaptor & coupling

3 = NEMA 34 motor adaptor & coupling

H = Hand crank

Blank = Self aligning recirculating linear ball bearings & 1060 Shafting

E = Engineered plastic linear bearings & 303 stainless steel shafting

T = PTFE (Teflon) coated lead screw
(If lubrication is not desired, PTFE coated lead screw and PV or PZ style nut is recommended)

Model LS10B05 Thru LS10B41

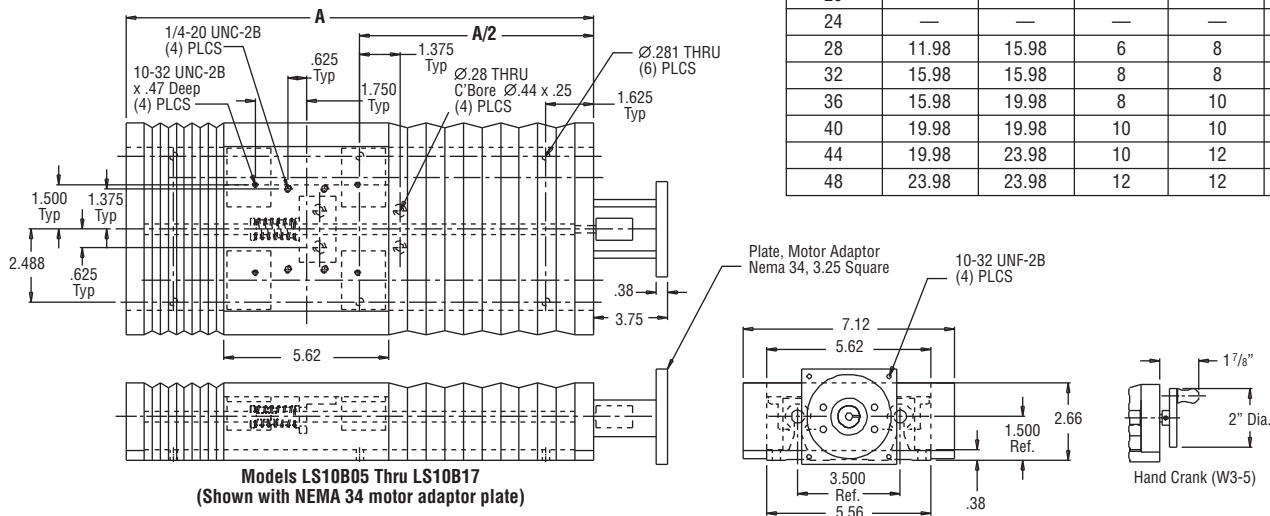

Model LS10B Dimensions

A Inches	B Inches	C Inches	D Inches	E Inches	Part Number
12	—	—	—	—	LS10B05
16	—	—	—	—	LS10B09
20	—	—	—	—	LS10B13
24	—	—	—	—	LS10B17
28	11.98	15.98	6	8	LS10B21
32	15.98	19.98	8	8	LS10B25
36	15.98	19.98	8	10	LS10B29
40	19.98	19.98	10	10	LS10B33
44	19.98	23.98	10	12	LS10B37
48	23.98	23.98	12	12	LS10B41

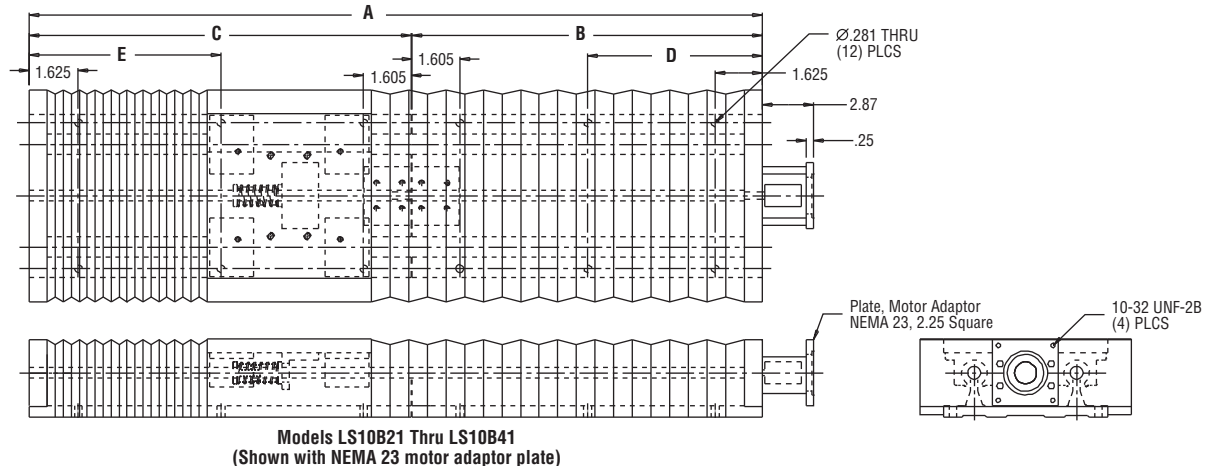

POSITIONING STAGES

Ball or Crossed Roller

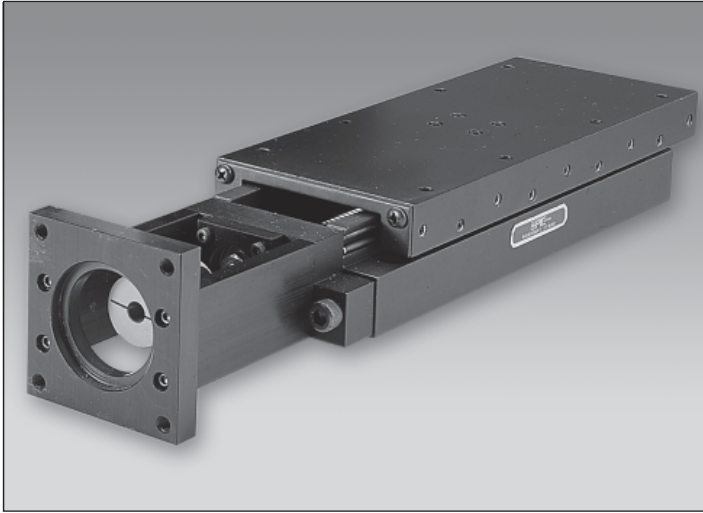

PIC's industrial grade stages (tables) provide solutions for indexing where the strict requirements of scientific stages are not needed. Mounting holes in top and base are located to easily allow two stages to be configured as an X-Y positioner. For optional Z bracket configuration, consult factory.

- Ball or Crossed Roller
- Acme or Ball Screw
- NEMA 23 Motor Mount or Hand Crank
- X, XY or XYZ Style

Maximum Loads —

Load centered on carriage top, carriage centered on base (lbs.)

Loads (lbs.)	Travel (in.)					
	2	4	6	8	10	12
Ball Slide	30	40	50	60	80	100
Crossed Roller	240	312	408	672	744	840

Load centered on carriage top, carriage at full travel position (lbs.)

Loads (lbs.)	Travel (in.)					
	2	4	6	8	10	12
Ball Slide	20	20	20	20	30	40
Crossed Roller	153	138	147	309	318	324

Maximum Moments —

Load centered on carriage top (lbs.-in.)

Ball Slide	Travel (in.)					
	2	4	6	8	10	12
Roll Axis, X	30	41	51	61	82	102
Pitch Axis, Y	20	33	47	62	91	121
Yaw Axis, Z	10	16	23	31	45	60
Crossed Roller	2	4	6	8	10	12
Roll Axis, X	246	320	418	689	763	861
Pitch Axis, Y	126	184	262	479	538	617
Yaw Axis, Z	63	92	131	239	269	308

Specifications

Flatness (no load):	±.0002 in/in
Straightness:	±.0002 in/in
Repeatability:	Within .0004 inches
Positional Accuracy:	±.0006 in/in
Break-a-way Torque:	10 to 15 oz-in* *ACME Anti-backlash Nut

Material

Carriage and Base:	Black, Anodized Aluminum
Rolling Elements:	Hardened Steel

Lead Screw and Nut:

Acme	303 Stainless Steel Screw
Acetal	Teflon & Silicon filled nut
Ball	17-4PH Stainless Steel Rc 40 screw and nut

Optional Configurations

For manual applications the tables are supplied without motor mount and coupling — just substitute “M” for “C” in the part number. Manual units will be fitted with a hand crank.

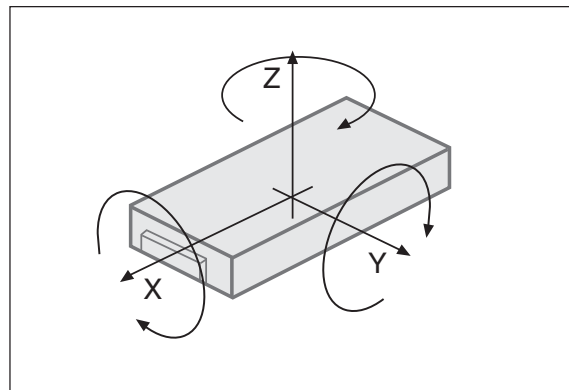

POSITIONING STAGES

Ball or Crossed Roller

Ordering Code

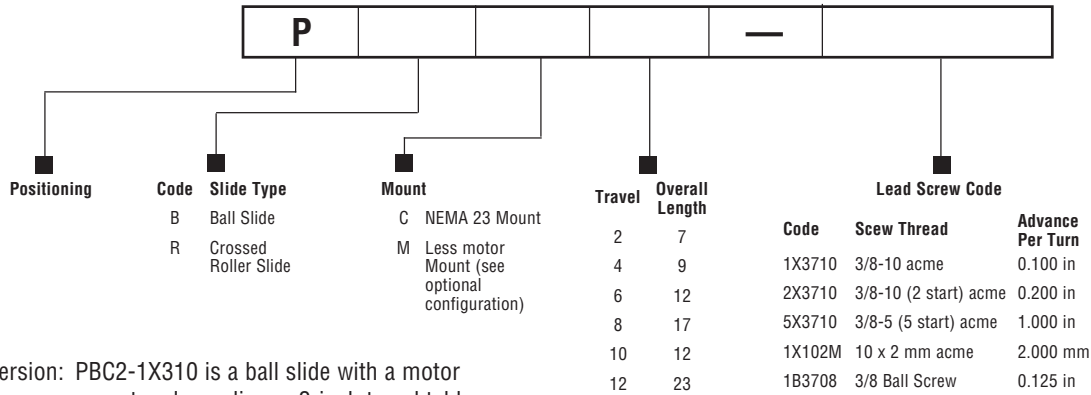

Example

Standard Version: PBC2-1X310 is a ball slide with a motor mount and coupling, a 2-inch travel table, and a .1-inch lead.

Optional Version: PBMA2-1X310 is the same table and lead less the motor mount and coupling, but includes hand crank

Outline Dimensions

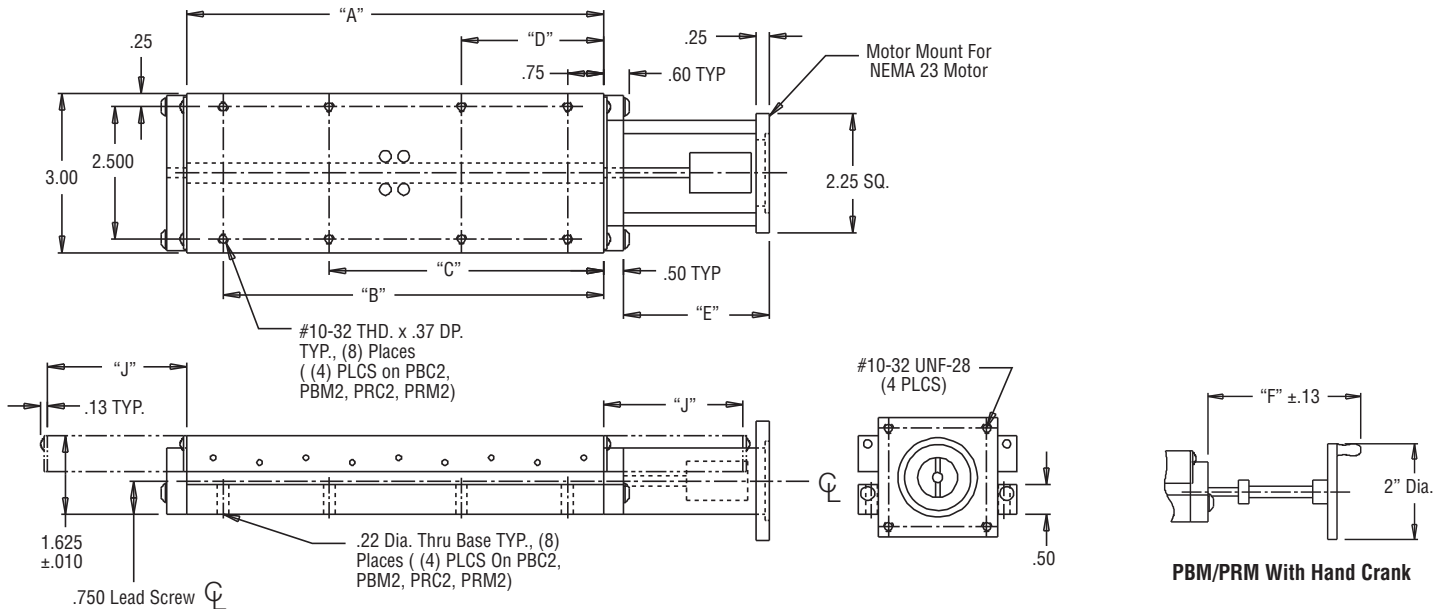

A	B	C	D	E	F	G	H	I	J	Part Number
4.00	N/A	3.25	0.75	2.00	2.75	0.75	3.25	N/A	1.00	PB 2 / PR 2
6.00	5.25	4.25	1.75	2.00	2.75	1.75	4.25	5.25	2.00	PB 4 / PR 4
8.00	7.25	5.25	2.75	3.00	3.75	2.75	5.25	7.25	3.00	PB 6 / PR 6
12.00	11.25	7.25	4.75	4.00	4.75	3.75	8.25	11.25	4.00	PB 8 / PR 8
14.00	13.25	8.25	5.75	5.00	5.75	4.75	9.25	13.25	5.00	PB 10 / PR 10
16.00	15.25	9.25	6.75	6.00	6.75	5.75	10.25	13.25	6.00	PB 12 / PR 12

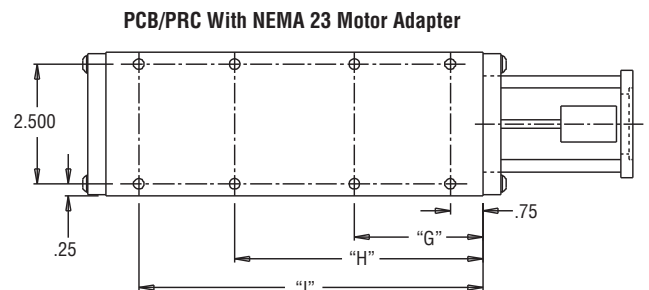

ROTARY TABLE

Ratios 45:1, 90:1, 180:1



Features

- PIC's Rotary Tables provide smooth precise rotational positioning.
- No Lube required.
- Can be mounted in any plane.
- Hand Crank or NEMA 17 motor mount.
- Will mount to PIC's line of Systems 9, 10 and PBX & PRX
- Positioning Stages.

Material

Body: Black Anodized Aluminum
 Worm: 303 Stainless Steel
 Gear: 2024 Aluminum
 Bearings: Stainless Steel ABEC 7 + Thrust
 Shafting : 303 Stainless Steel

Specifications

NEW PRODUCT!

Specifications are being finalized. See our website (or call factory) for product details, price and delivery.

www.pic-design.com

Ratio*	Motor Mount** Part Number	Hand Crank Part Number
45:1	RT4-45-M	RT4-45-H
90:1	RT4-90-M	RT4-90-H
180:1	RT4-180-M	RT4-180-H

* For special ratios consult factory
 ** Use of NEMA 17 motor eliminates hand crank

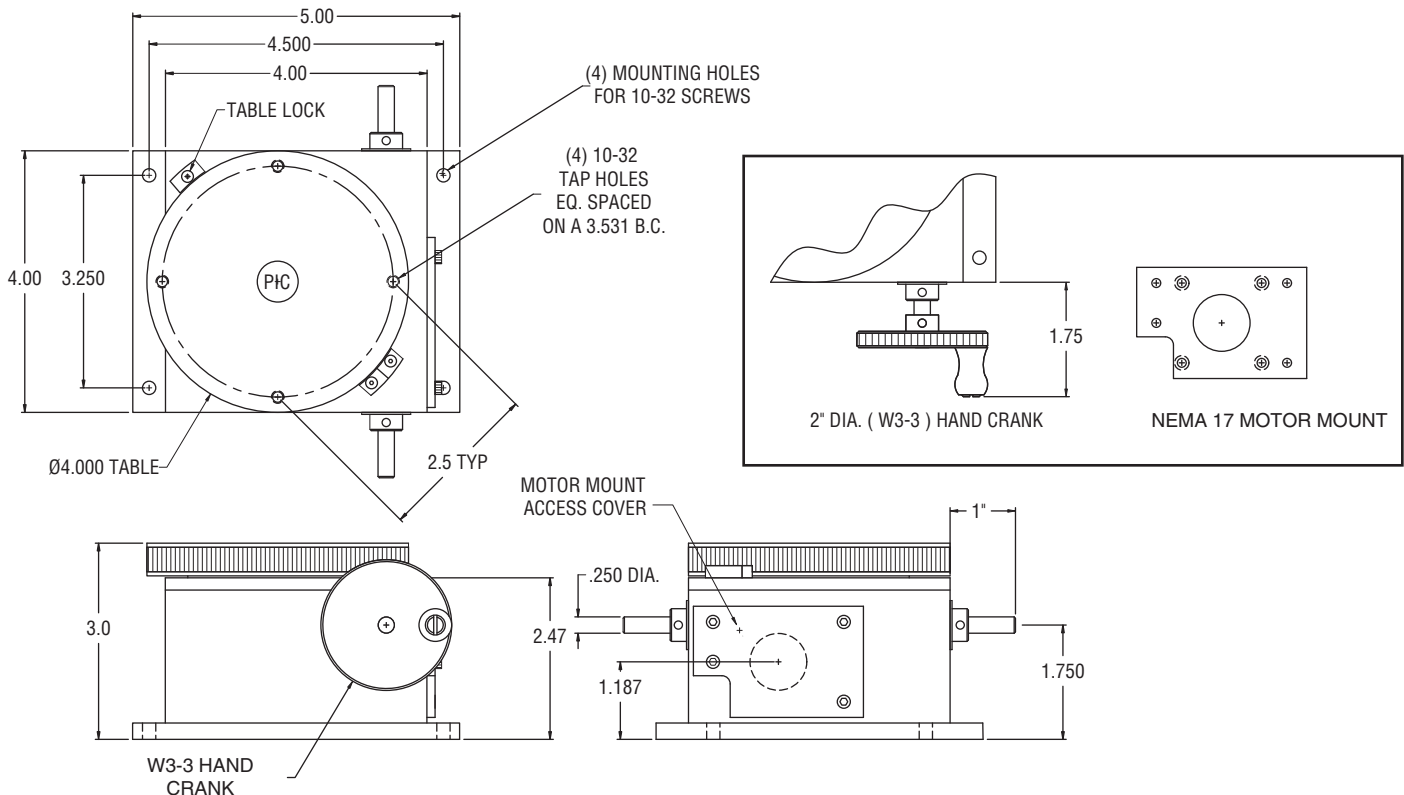

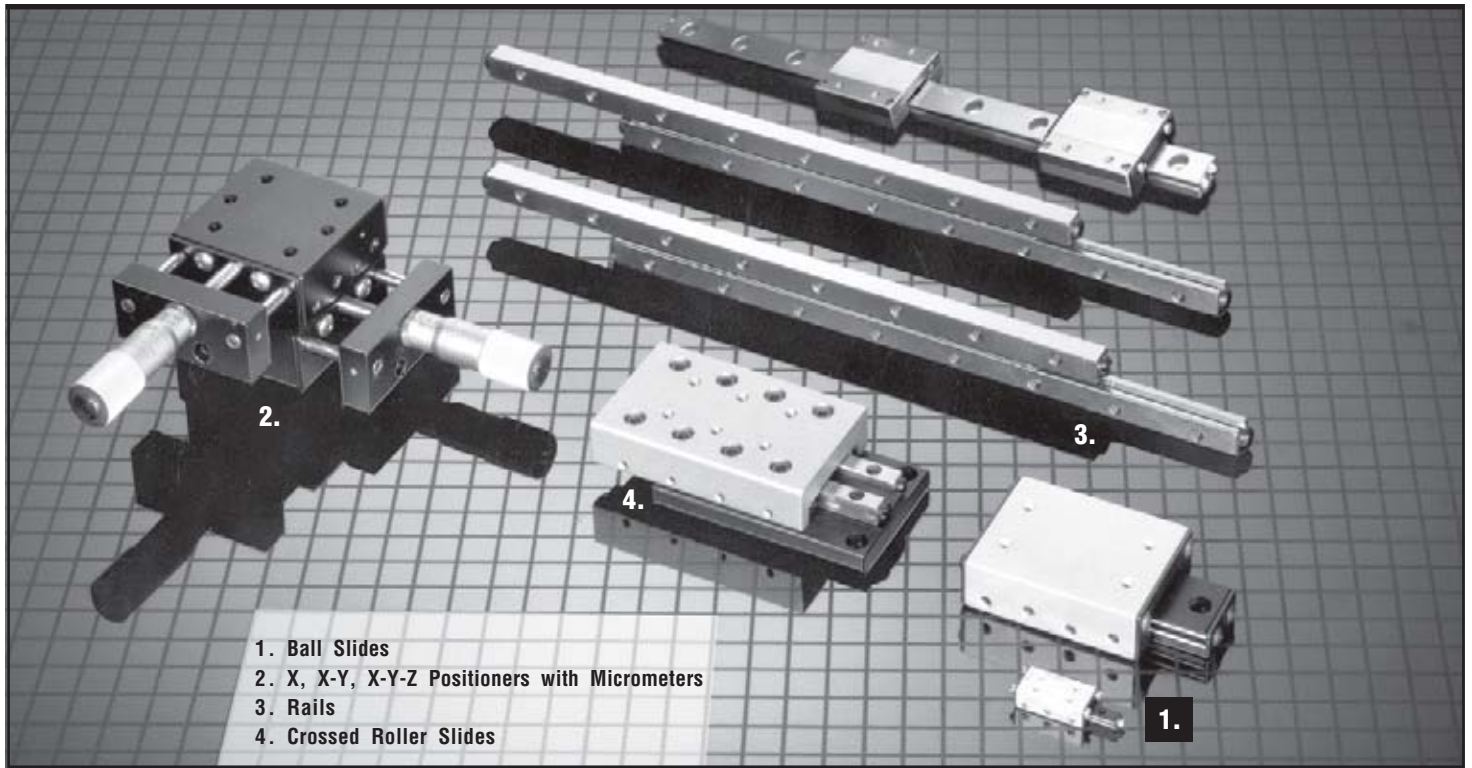

1. Ball Slides
 2. X, X-Y, X-Y-Z Positioners with Micrometers
 3. Rails
 4. Crossed Roller Slides

PIC Design has added several new linear slide products to its line of precision Ball Slides. For higher load carrying capability and higher accuracy, a line of crossed roller rails and slides has been added. The Ball Slide line has been expanded to include additional sizes and PIC now offers a line of X, XY and XYZ Positioners with micrometers.

PIC Linear Slides — a brief overview.

BALL SLIDES

Precision Ball Slides assemblies are used as guides and supports in various applications providing low friction and high accuracy for precise, linear, uniform movement. The wide range of sizes and load carrying capabilities enables the designer or engineer to select the appropriate ball slide for the particular application. Ball slides are used in many applications, such as assembly fixtures, packaging machinery, medical and optical instruments, computer disk drives and printers, copiers and other precision equipment.

The slides low friction is due to the hardened stainless steel balls rolling between ground hardened rods, providing low starting and rolling friction for moving light and heavy loads. The high accuracy is attributed to the aluminum bodies having flat,

smooth top and bottom surfaces. Riding parallel to the line of motion, they provide straight line accuracy to .0005" per inch of travel. The assembled units are preloaded to prevent side play and backlash and to ensure positional repeatability to .0002" to maintain precise, uniform, linear movement.

POSITIONERS WITH MICROMETERS

The positioners are supplied assembled and feature low friction, high accuracy and repeatability as do the ball slides. PIC positioners are supplied for multi-axis applications: "X", "XY" and "XYZ" configurations. Spring loaded micrometer drives allow precise repeatable adjustments with low friction and zero backlash. (Micrometers available in inch or metric units). The product line includes the subminiature series which contains the smallest commercially available positioner and the standard series which is ideal for most gaging and positioning applications, such as measuring instruments and optical assemblies.

RAILS

Rails, also referred to as Crossed Roller Linear Bearings Sets, are compact precision bearings that can support and guide high loads with high accuracy and repeatability, low friction and low starting force. Each bearing consists of a pair of hardened steel ways containing 90° vee grooves and a row of alternately crossed cylindrical rollers. The

hardened steel rollers are captive in a brass cage for easy handling and assembly and permanent alignment. These ways are installed face to face with the rollers between the vee grooves, so that the user can mount in any direction or orientation to fulfill the application without adding a whole slide to the system. Rails are sold in sets consisting of two bearings (4 way bars, 2 roller cages and end stops).

CROSSED ROLLER SLIDES

The crossed roller slides incorporate the rails to provide precise linear motion with low friction at a higher load carrying capability than ball slides. The crossed roller slides are available in either a steel or aluminum body. The steel crossed roller slides offer a high support stiffness for the load, thus resulting in a straight line accuracy of .00008" over 4 inches of length and .00012" over 12.5" of length. The aluminum crossed roller slides offer low cost and lightweight body that may be necessary in weight sensitive applications. The straight line accuracy of the aluminum slide is .0001" per inch of travel.

The steel or the aluminum crossed roller slides are available in a variety of sizes for applications including precision instruments, office and communications equipment, surface and tool grinders, assembly fixtures and other applications which require precise, uniform linear motion.

TECHNICAL SECTION

PIC Design has included a straight line accuracy table to select the type of linear slide that will meet the accuracy required by the particular application. Straight line accuracy is the amount of deflection over the center line of the carriage and parallel to the line of motion. Also included are the maximum travel and maximum load capacity of each series of Ball Slides, X-XY-XYZ positioners with micrometer, aluminum and steel crossed roller slides.

STRAIGHT LINE ACCURACY TABLE

ACCURACY	TYPE
.0005 in/in	Ball Slides
.0005 in/in	Positioners
.00008 in/in	Steel Crossed Roller Slides
.0001 in/in	Aluminum Crossed Roller Slides

BALL SLIDES

SERIES	FEATURES	FEATURES	
		Travel	Load
PB04	Smallest commercially available ball slides. Long life and high accuracy for computer disk drives, printers, plotters, and copiers.	0.5" -15"	1.5 lb
PB05	Same accuracy as larger slides. Ideal for compact instruments.	0.5" -50"	4-18 lb.
PB08	Compact profile for restricted spaces, yet high load capacity.	0.5" -50"	8-18 lb.
PB1	Popular series meets many needs with moderate travel requirements. Wider profile for good load support.	0.5" -30"	10-18 lb
PB12	Heavier balls and ways provide high load capacity and long travel for controls, other medium duty applications.	0.75" -80"	15-40 lb
PB15	Larger slides for heavy loads with no sacrifice in life, accuracy, and repeatability.	1.0" -80"	15-55 lb
PB2	Rugged slides for high loads, very short overall lengths.	1.0" -80"	20-90 lb
PB3	Widest profile for longest travel, highest capacity.	1.00" -120"	35-205 lb

X, XY, XYZ POSITIONERS WITH MICROMETERS

SERIES	FEATURES	FEATURES	
		Micrometer	Load
100-200	Subminiature ball slides only .36" high with miniature micrometer drives for restricted space applications.	.350"	4 lb
300	Heavy duty subminiature series. Standard and low profile XYZ models.	.350"	12 lb
400, 450, 500	Popular standard series meets majority of gaging and positioning needs. Low profile XYZ model included.	.350", .10" 13mm, 25mm	20-42 lb
1200-2200	Standard duty series with oversize table area. Standard and low profile XYZ models.	.10"	30 lb

ALUMINUM CROSSED ROLLER SLIDES

SERIES	FEATURES	FEATURES	
		Max. Travel in (mm)	Max. Load lb (kg)
P4BT1000A	The same 1.5mm roller used in the P4BT1000 series is utilized, but is a lighter weight and lower cost outside of the extended travel.	3 (76)	198 (90)
P4BT2000A	The 2mm crossed roller rail set with a larger profile than the 1000A series.	3 (76)	125 (90)
P4BT3000A	The 3mm roller has the same travel as the P4BT2000A, but more than twice the load carrying capability.	3 (76)	477 (216)
P4BT4000A	The 4mm set of crossed roller rails offers 25% more travel with 25% more load carrying capability than the P4BT3000A series.	4 (102)	723 (328)

STEEL CROSSED ROLLER SLIDES

SERIES	FEATURES	FEATURES	
		Max. Travel in (mm)	Max. Load lb (kg)
P4BT1000	The smallest slide of the line utilizing a set of the 1.5mm crossed roller rails.	1.760 (32)	5.7 (26)
P4BT2000	A series with 25% more width of carriage with a most 10X the load carrying capacity of the P4BT1000 series.	1.969 (50)	209 (95)
P4BT3000	The 3mm crossed roller rail set profile with same straight line accuracy as the smaller series.	3.543 (90)	687 (312)
P4BT4000	The 4mm roller slide maintains the high straight line accuracy with a high load carrying capability.	4.134 (105)	1034 (470)
P4BT6000	The 6mm roller slide is capable of carrying heavy loads over 10" of travel.	10.43 (265)	3223 (1462)

Typical coefficient of friction is .003

When designing a system that requires the use of linear motion, the straight line accuracy, as well as the repeatability, stiffness and the cost of the linear slide should be looked at. PIC has included a brief but informative description of the types of linear slides included, so that the proper linear slide will be selected for a particular application.

Ball Slides generally are used in reciprocating applications requiring 1/2" or less of travel and loads below 200 lbs. They are comparable in accuracy to linear ball bushings and offer less complexity and less cost than ball bushings within the same travel range. The Ball Slides are capable of high speed and long life with no lubrication and are not affected by common industrial contaminants.

The Positioners with micrometers are used in applications which are static or the motion is intermittent, with repeatability being most significant. The positioners can be located in the X, XY or X-Y-Z axes with little modification needed.

The crossed roller slide performs the same function as ball slides, but are capable of higher accuracy and loads. The crossed roller slide may be pre loaded more heavily than a ball slide and still maintain low friction. The steel crossed roller slide will be 4 times as stiff or 1/3 the axial play and have 10 times the load capacity of a similar size ball slide. The aluminum crossed roller slide utilizes the same rails as the steel crossed rollers, but are lighter in weight, therefore sacrificing stiffness and accuracy, but are more economical.

The crossed roller slides reduce the installation complexity if they can be accommodated into the system. The rails are used for applications that require the high accuracy of the crossed rollers with the mounting and carriage bases being a part of the application.

BALL AND CROSSED ROLLER SLIDES AND POSITIONERS

Load Ratings and Life Estimates

The rated load capacity on slides may be a mass load on a horizontal slide, or a force load normal to the mounting surface in any position. The rated load must be centered and distributed over the slide, and the base must be fully supported on a flat mounting surface so that the slide does not act as a beam subject to concentrated or distributed bending forces. Loads supported by protruding arms reduce accuracy and load capacity by acting as levers or ratio arms, and should be avoided even when load forces are small. When used at the rated load capacity and moderate speeds, a life of 10 million inches of travel can be expected. The expected life at one half the rated load is 100 million inches.

Friction and Lubrication

The coefficient of friction is lower for linear bearings than for rotary bearings, where the peripheral track is shorter on the inner race than on the outer race, causing the ball or roller to skid on one or the other. The balls or rollers run exactly equal distances on the pair of tracks in linear bearings, permitting the balls or rollers to run without friction, wear, or skidding at any preload. The typical coefficient of friction for ball slides is .003.

The slides are lightly lubricated during assembly, and are self-cleaning in normal service. Additional lubrication is required for speeds above 1800 inches/min., and is advisable at lower speeds where high loads are applied in continuous duty applications.

Mounting and Accuracy

The mounting surfaces of the slides are machined flat and smooth, and parallel to each other and the line of motion. They must be mounted on smooth, flat supports that will not deflect under load. Especially with long slides of small cross section, binding may be caused by distortion of the bottom member when mounted on

Maximum Operating Temperature: 100°C(212°F)

irregular surfaces. If so, round shims or spacers may be placed over the mounting screws to raise the slide above the surface asperities. Bedding in epoxy resin is also recommended.

Modifying Length of Travel for Rails

For a given length of bearing way, since there is no slip at any load, both length of travel and load capacity depend on the number of rollers and their pitch. The number of rollers supplied with each standard bearing set provides a travel distance of approximately 60% of the way length.

In some cases (e.g., when mounting space is restricted) it may be practical to increase travel at the expense of load capacity by removing one or more rollers instead of selecting a longer bearing. Since travel extends symmetrically around the mean position, the travel increase is twice the pitch for each roller removed. Similarly, the load capacity for the set is reduced by twice the load capacity per roller

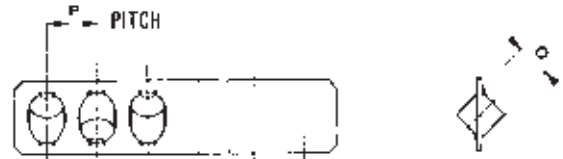

Roller Diameter (D) in (mm)	Roller Distance (P) in (mm)	Increase of Travel for Each Roller Cut-Off in (mm)	Roller Load Carrying Capacity Per Roller lbs (kg)
059 (1.5)	098 (2.5)	197 (5)	8.8 (4)
079 (2)	158 (4)	316 (8)	13.2 (6)
118 (3)	197 (5)	394 (10)	22.0 (10)
158 (4)	275 (7)	550 (14)	44.0 (20)
236 (6)	334 (8.5)	668 (17)	88.0 (40)

Mounting The Rail Sets

In mounting of the rail sets, the maximum deviation from parallelism between the two surfaces should not exceed the value listed in the chart below according to the length of rail. The mounting and bearing surfaces must be smooth and flat and accurately parallel, coplanar or perpendicular respectively to achieve maximum accuracy of the rail set.

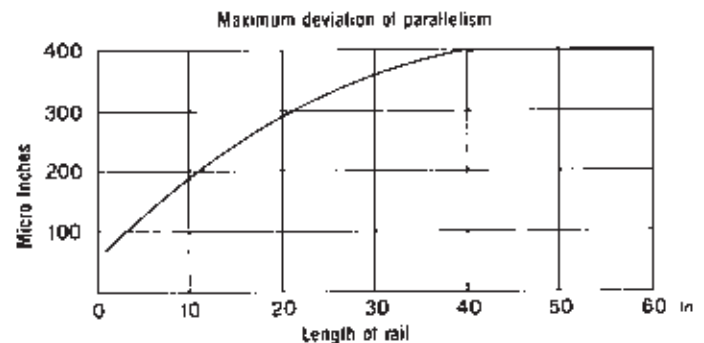

BALL SLIDES

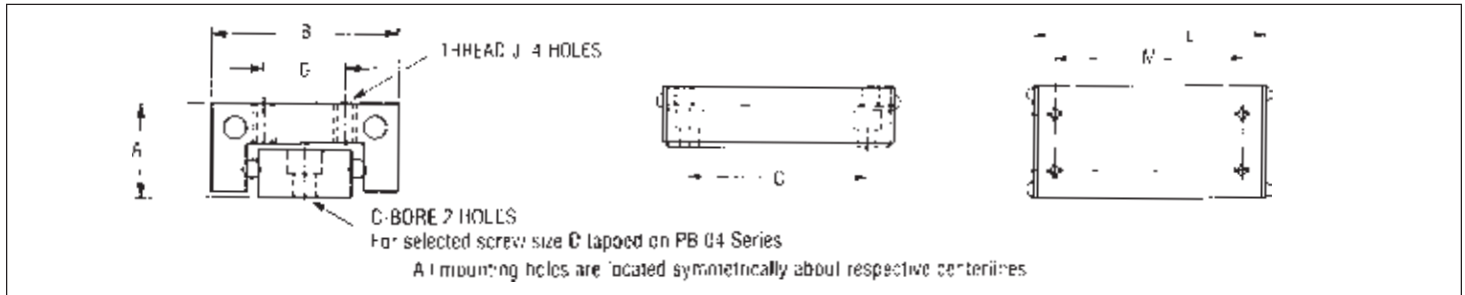

Specifications

Straight line accuracy: .0005/inch of travel

Repeatability: .0002

Material: Aluminum Base and Carriage

Finish: Clear/Black Anodize - AT PIC Option

* Min travel, centered around mean position
Typical overtravel 0.06" each direction

Total Travel*	Length L	Height A	Width B	Carriage Hole Spacing		Hole Spacing C	J	D	Load Capacity (lbs.)	Part Number
				M	G					
50	75	22	38	375	156	375	2.56	2.56	1.0	PB04-05
1.00	1.25	23	38	375	156	375	2.56	2.56	1.5	PB04-10
1.50	1.75	23	38	1.375	156	375	2.56	2.56	1.5	PB04-15
50	1.06	32	56	625	218	750	2.56	2.56	4	PB05-05
1.00	2.06	32	56	1.625	218	1.375	2.56	2.56	6	PB05-10
2.00	3.06	32	56	2.625	218	2.375	2.56	2.56	12	PB05-20
3.00	4.06	32	56	3.625	218	3.375	2.56	2.56	14	PB05-30
4.00	5.06	32	56	4.625	218	4.375	2.56	2.56	16	PB05-40
5.00	6.06	32	56	5.625	218	5.375	2.56	2.56	18	PB05-50
50	1.06	40	75	625	375	750	4.40	4.40	6	PB08-05
1.00	2.06	40	75	1.625	375	1.375	4.40	4.40	10	PB08-10
2.00	3.06	40	75	2.625	375	2.375	4.40	4.40	12	PB08-20
3.00	4.06	40	75	3.625	375	3.375	4.40	4.40	14	PB08-30
4.00	5.06	40	75	4.625	375	4.375	4.40	4.40	16	PB08-40
5.00	6.06	40	75	5.625	375	5.375	4.40	4.40	18	PB08-50
50	1.56	50	1.00	1.250	437	1.750	6.32	4.40	10	PB1-05
1.00	2.56	50	1.00	2.250	437	2.750	6.32	4.40	12	PB1-10
1.50	3.06	50	1.00	3.250	437	3.750	6.32	4.40	13	PB1-15
2.00	3.56	50	1.00	4.250	437	4.750	6.32	4.40	15	PB1-20
3.00	4.56	50	1.00	5.250	437	5.750	6.32	4.40	18	PB1-30
75	1.56	53	1.06	1.250	437	1.125	6.32	6.32	15	PB12-08
1.50	2.56	53	1.06	2.250	437	2.125	6.32	6.32	18	PB12-15
2.00	3.56	53	1.06	3.250	437	3.125	6.32	6.32	20	PB12-20
3.00	4.56	53	1.06	4.000	437	3.250	6.32	6.32	25	PB12-30
4.00	6.00	53	1.06	5.500	437	4.000	6.32	6.32	30	PB12-40
6.00	8.00	53	1.06	7.500	437	5.000	6.32	6.32	35	PB12-60
6.00	10.00	53	1.06	9.500	437	7.000	6.32	6.32	40	PB12-80
1.00	2.00	62	1.50	1.375	625	1.500	6.32	6.32	15	PB15-10
2.00	3.00	62	1.50	2.375	625	2.500	6.32	6.32	20	PB15-20
3.00	4.00	62	1.50	3.375	625	3.500	6.32	6.32	25	PB15-30
4.00	6.00	62	1.50	5.375	625	4.000	6.32	6.32	35	PB15-40
6.00	8.00	62	1.50	7.375	625	5.000	6.32	6.32	45	PB15-60
8.00	10.00	62	1.50	9.375	625	7.000	6.32	6.32	55	PB15-80
1.00	2.00	75	1.75	1.375	875	1.875	6.32	6.32	20	PB2-10
1.50	2.75	75	1.75	2.125	875	2.250	6.32	6.32	30	PB2-15
2.00	3.25	75	1.75	2.625	875	2.750	6.32	6.32	42	PB2-20
3.00	4.00	75	1.75	3.375	875	3.500	6.32	6.32	52	PB2-30
4.00	6.00	75	1.75	5.375	875	4.000	6.32	6.32	60	PB2-40
6.00	8.00	75	1.75	7.375	875	5.000	6.32	6.32	75	PB2-60
8.00	10.00	75	1.75	9.375	875	7.000	6.32	6.32	90	PB2-80
1.00	2.62	1.00	2.52	2.125	1.250	2.125	10.32	10.32	30	PB3-10
1.50	2.62	1.00	2.52	1.625	1.250	1.875	10.32	10.32	35	PB3-15
2.00	4.00	1.00	2.52	3.000	1.250	3.275	10.32	10.32	62	PB3-20
3.00	5.00	1.00	2.52	4.000	1.250	4.375	10.32	10.32	88	PB3-30
4.00	6.00	1.00	2.52	5.000	1.250	5.375	10.32	10.32	118	PB3-40
5.00	6.00	1.00	2.52	7.000	1.250	7.375	10.32	10.32	135	PB3-50
6.00	9.00	1.00	2.52	3.000 h ₂ o	1.250	7.000	10.32	10.32	150	PB3-60
9.00	12.00	1.00	2.52	3.000 h ₂ o	1.250	10.000	10.32	10.32	165	PB3-80
12.00	15.00	1.00	2.52	3.000 h ₂ o	1.250	13.000	10.32	10.32	205	PB3-120

ECONOMY BALL SLIDES

For Linear Motion Applications

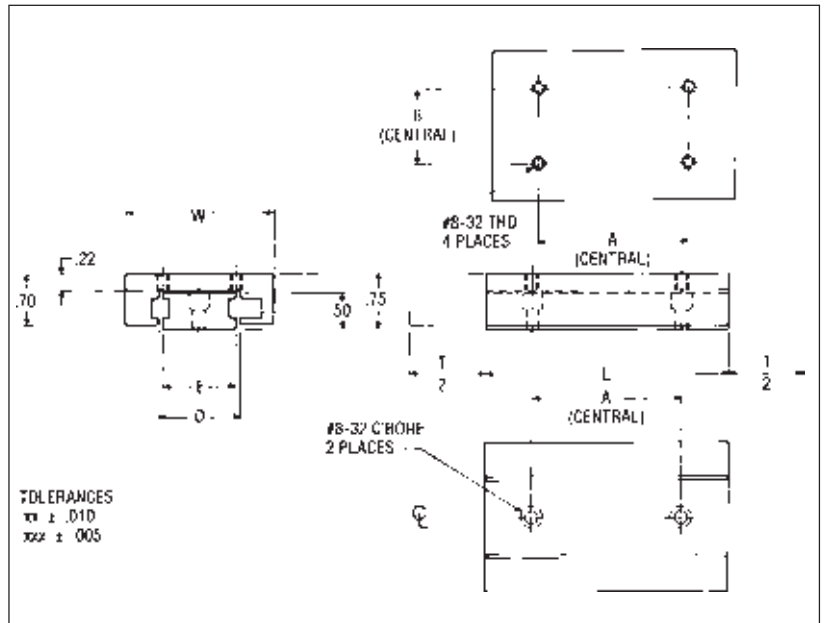

Material: Aluminum Base and Carriage

Finish: Black Anodize

Specifications

Straight line accuracy: .001" / inch of travel
 Repeatability: .001

PIC's economy Ball Slides, with their unique conforming pre-loaded mechanism, provide economic solutions to linear motion applications where extreme accuracy is not required. These cost-effective slides provide the repeatability needed for most automation and robotic applications, without the need for expensive four-digit accuracy of conventional slides.

This unique PIC slide utilizes conventional, hardened rod raceways and balls, combined with a proprietary elastomer gib for even and continuous linear bearing preload. The conforming elastomeric bearing preload tends to negate the limited shock load separation of conventional linear ball slides with no degradation in reliability and at an economical cost.

Travel (In.)	W	L	A	B	D	E	Load Capacity (lbs)	Part No.
1.0		2.00	1.000				20	PBE-122
2.0	2.00	3.00	2.000	1.000	1.10	1.00	30	PBE-223
3.0		4.00	3.000				40	PBE-324
2.0		4.00	3.000				30	PBE-234
3.0		5.00	4.000				40	PBE-335
4.0	3.00	6.00	5.000	2.000	2.10	2.00	50	PBE-436
5.0		7.00	6.000				60	PBE-537
6.0		8.00	7.000				70	PBE-638

ALUMINUM CROSSED ROLLER SLIDES

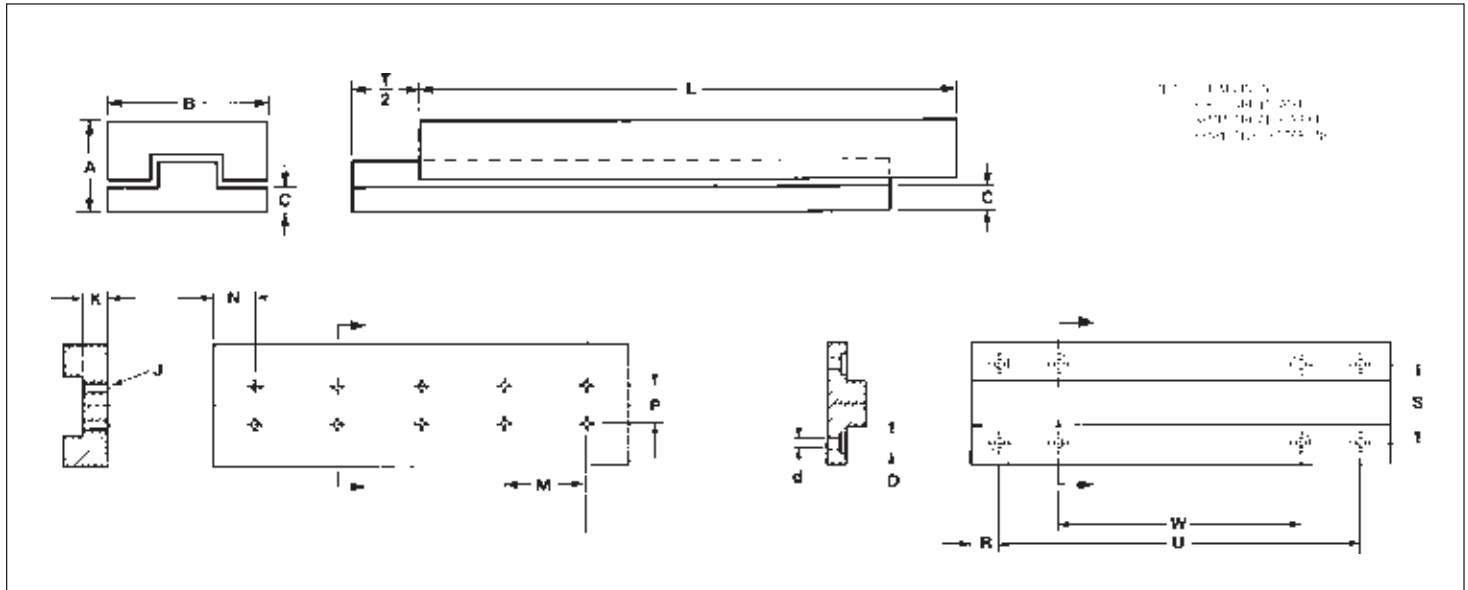

Specifications

Straight line accuracy: .0061 inch of travel

Material: Aluminum Base and Carriage

Hardened Steel Rails and Rollers

Finish: Carriage — Gold Anodize Base — Black Anodize

Travel Length and Load Selection

Dimension in Inches (mm)		Carriage Mounting Holes (Threaded)			Base Mounting Holes (Counterbored)			Load Capacity		Part No.
Travel T	Length L	No. Holes	No. Spaces	Spacing M	No. Holes	Spacing U	Spacing W	LBF	Kgf	
1.00	1.969 (50)	4	1	59.1 (15)	4	1.575 (40)	-	96	(44)	PNBT-1050A
1.50	2.559 (65)	6	2	59.1 (15)	4	2.165 (55)	-	114	(52)	PNBT-1065A
2.00	3.150 (80)	8	3	59.1 (15)	8	2.756 (70)	1.575 (40)	145	(66)	PNBT-1080A
2.50	3.740 (95)	10	4	59.1 (15)	8	3.346 (85)	2.165 (55)	162	(74)	PNBT-1095A
3.00	4.921 (125)	14	6	59.1 (15)	8	4.528 (115)	3.346 (85)	198	(90)	PNBT-1125A
1.00	1.969 (50)	4	1	59.1 (15)	4	1.575 (40)	-	96	(44)	PNBT-2050A
1.50	2.559 (65)	6	2	59.1 (15)	4	2.165 (55)	-	114	(52)	PNBT-2065A
2.00	3.150 (80)	8	3	59.1 (15)	8	2.756 (70)	1.575 (40)	145	(66)	PNBT-2080A
2.50	3.740 (95)	10	4	59.1 (15)	8	3.346 (85)	2.165 (55)	162	(74)	PNBT-2095A
3.00	4.921 (125)	14	6	59.1 (15)	8	4.528 (115)	3.346 (85)	198	(90)	PNBT-2125A
1.00	2.165 (55)	2	-	-	4	1.378 (35)	-	193	(88)	PNBT-3055A
2.00	4.134 (105)	6	2	98.4 (25)	4	3.346 (85)	-	338	(154)	PNBT-3105A
3.00	6.102 (155)	10	4	98.4 (25)	6	5.315 (135)	-	477	(217)	PNBT-3155A
2.00	3.346 (85)	2	-	-	4	2.559 (65)	-	430	(196)	PNBT-4085A
3.00	4.921 (125)	4	2	1.575 (40)	4	4.134 (105)	-	600	(273)	PNBT-4125A
4.00	6.496 (165)	6	4	1.575 (40)	6	5.709 (145)	-	723	(329)	PNBT-4165A

Profile and Mounting Dimensions

A ± .005 (0.13)	B ± .010 (25)	C	Carriage				Base Spacing				Series
			Spacing		Thread Depth		Counterbore				
			H	P	J	K	R	S	D	d	
590 (15)	1.781 (30)	150 (4.1)	689 (17.5)	394 (10)	4-40	177 (4.5)	197 (5)	866 (22)	198 (5)	125 (3.1)	PNBT-1000A
827 (21)	1.575 (40)	256 (6.5)	689 (17.5)	591 (15)	6-32	315 (8)	197 (5)	1181 (30)	241 (6.1)	144 (3.7)	PNBT-2000A
1102 (28)	2.362 (60)	354 (9)	1063 (27.5)	964 (25)	10-32	413 (10.5)	394 (10)	1575 (40)	328 (8.3)	197 (5)	PNBT-3000A
1378 (35)	3.150 (80)	413 (10.5)	1673 (42.5)	575 (40)	10-32	512 (13)	394 (10)	2165 (55)	328 (8.3)	197 (5)	PNBT-4000A

Measurement in inches

STEEL CROSSED ROLLER SLIDES

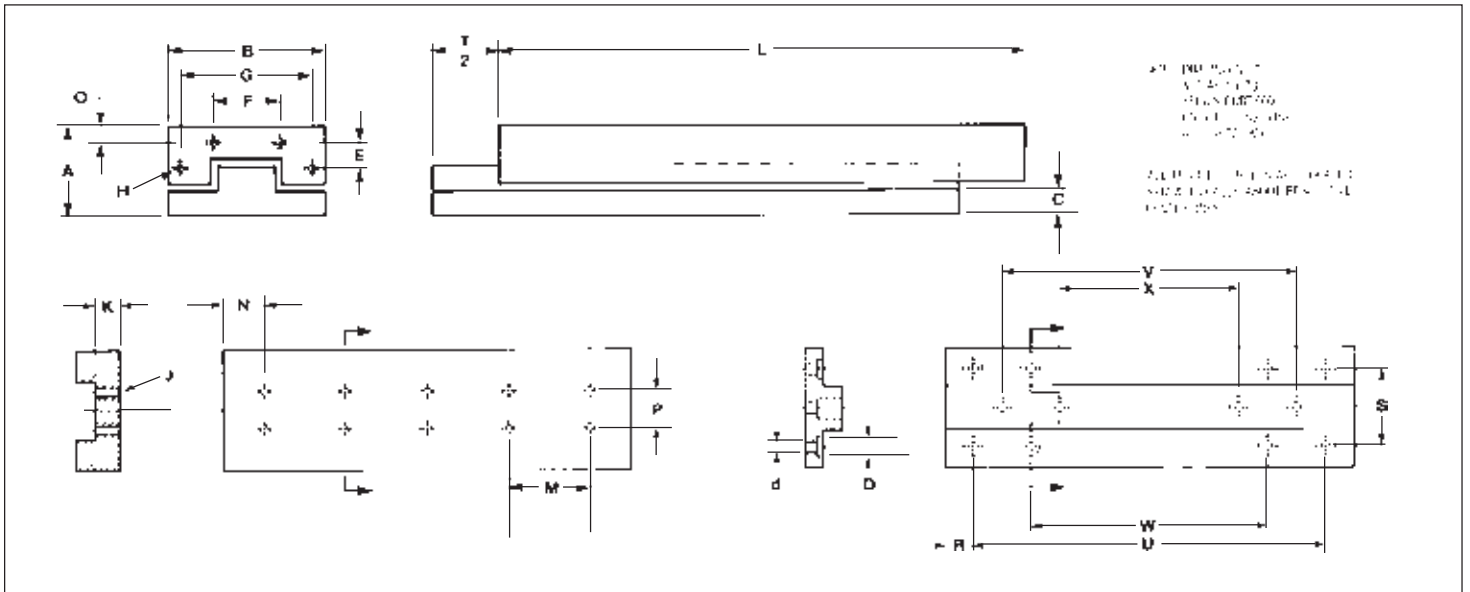

Specifications

Straight line accuracy: .00008" for 1.0" — 4.0" of length .00012" for 4.1" — 12.5" of length

Material: Steel Base and Carriage

Finish: Black Oxide finish

Travel Length and Load Selection

Dimension in Inches (mm)		Carriage Mounting Holes (Threaded)			Base Mounting Holes (Counterbored)				Load Capacity		Part No.
Length L	Travel T	No. Holes	No. Spaces	Spacing M	No. Holes	Spacing U	Spacing W	Spacing V	LBF	(Kgf)	
0.84 (21)	.472 (12)	2	—	—	4	.709 (18)	—	—	28	(12)	PNBT-1025
1.375 (35)	.709 (18)	4	1	.394 (10)	4	1.108 (28)	—	—	35	(16)	PNBT-1035
1.772 (45)	.984 (25)	6	2	.394 (10)	4	1.496 (38)	—	—	44	(20)	PNBT-1045
2.165 (55)	1.250 (32)	8	3	.394 (10)	6	1.890 (48)	1.102 (28)	—	57	(26)	PNBT-1055
1.375 (35)	.709 (18)	2	—	—	4	.984 (25)	—	—	68.0	(40)	PNBT-2035
1.969 (50)	1.161 (30)	4	1	.591 (15)	4	1.575 (40)	—	—	138.0	(63)	PNBT-2050
2.559 (65)	1.575 (40)	6	2	.591 (15)	4	2.165 (55)	—	—	165.0	(75)	PNBT-2065
3.150 (80)	1.969 (50)	8	3	.591 (15)	6	2.756 (69)	1.575 (40)	—	209.0	(95)	PNBT-2080
2.165 (55)	1.161 (30)	2	—	—	4	1.378 (35)	—	—	277.0	(126)	PNBT-3055
3.150 (80)	1.772 (45)	4	1	.984 (25)	4	2.362 (60)	—	—	405.0	(184)	PNBT-3080
4.134 (105)	2.362 (60)	6	2	.984 (25)	4	3.345 (85)	—	—	484.0	(220)	PNBT-3105
5.118 (130)	2.953 (75)	6	3	.984 (25)	4	4.331 (110)	—	—	605.0	(275)	PNBT-3130
6.102 (155)	3.543 (90)	10	4	.984 (25)	6	5.315 (135)	—	3.34 (85)	682.0	(310)	PNBT-3155
3.346 (85)	1.969 (50)	2	—	—	4	2.559 (65)	—	—	616.0	(280)	PNBT-4085
4.921 (125)	2.953 (75)	4	1	1.575 (40)	4	4.134 (105)	—	—	858.0	(390)	PNBT-4125
6.496 (165)	4.134 (105)	6	2	1.575 (40)	4	5.709 (145)	—	—	1034.0	(470)	PNBT-4165
4.331 (110)	2.362 (60)	2	—	—	4	3.343 (90)	—	—	660.0	(400)	PNBT-5110
6.500 (165)	3.740 (95)	4	1	1.969 (50)	4	5.512 (140)	—	—	1518.0	(690)	PNBT-5160
8.266 (210)	5.118 (130)	6	2	1.969 (50)	6	7.480 (190)	—	3.543 (90)	1914.0	(870)	PNBT-6210
12.20 (310)	7.874 (200)	10	4	1.969 (50)	6	11.470 (290)	—	7.480 (190)	2640.0	(1200)	PNBT-6310

Measurement in inches

Profile and Mounting Dimensions

A ± .004		B ± .004		C	N	P	J	Dust Cover Attachment		Thread H	R	S	D	d	Series
								O	F						
689 (17)	1.181 (30)	2.17 (55)	492 (125)	394 (10)	M2	275 (7)	098 (2.5)	472 (12)	M2	138 (3.5)	866 (22)	135 (4.7)	106 (2.7)	—	PNBT-1000
827 (21)	1.575 (40)	258 (6.5)	689 (17.5)	591 (15)	M3	315 (8)	134 (3.4)	630 (16)	M2	197 (5)	1.181 (30)	252 (6.4)	153 (3.9)	—	PNBT-2000
1.02 (26)	2.362 (60)	354 (9)	1.053 (27)	984 (25)	M4	413 (10.5)	217 (5.5)	1.575 (40)	M3	394 (10)	1.575 (40)	315 (8)	197 (5)	—	PNBT-3000
1.378 (35)	3.150 (80)	413 (10.5)	1.673 (42.5)	575 (14)	M5	517 (13)	256 (6.5)	2.165 (55)	M3	394 (10)	2.165 (55)	374 (9.5)	220 (5.5)	—	PNBT-4000
1.772 (45)	3.937 (100)	512 (13)	2.165 (55)	984 (25)	M5	630 (16)	315 (8)	2.362 (60)	M4	394 (10)	2.362 (60)	433 (11)	263 (7.2)	—	PNBT-6000

ECONOMY CROSSED ROLLER SLIDES

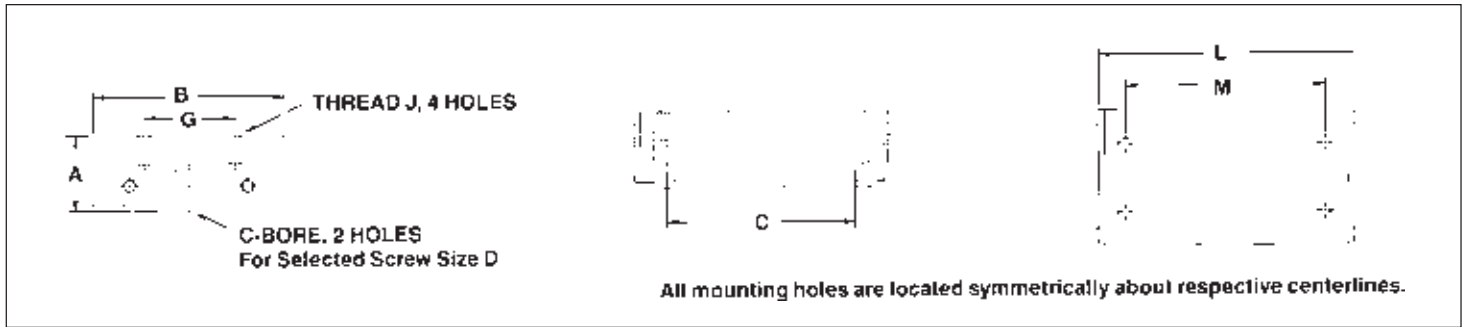

Specifications
 Straight line accuracy: .0001" / inch of travel
 Repeatability: .0001" Material: Aluminum Base and C carriage
 Finish: Black Anodize

Total Travel*	L	M	C	A	B	G	J	D	Lead Capacity (lbs.)	Part No.
50	1.00	.625	.750	.30	.56	2.15	2.56	2.56	30	PRB05-05
1.00	2.00	1.625	1.750	.32	.56	2.15	2.56	2.56	55	PRB05-10
2.00	3.00	2.625	2.375	.33	.56	2.15	2.56	2.56	66	PRB05-20
50	1.00	.625	.750	.40	.75	3.75	4.40	4.40	14	PRB08-05
1.00	2.00	1.625	1.375	.40	.75	3.75	4.40	4.40	24	PRB08-10
2.00	3.00	2.625	2.375	.40	.75	3.75	4.40	4.40	34	PRB08-20
1.00	2.00	2.250	2.125	.50	1.00	4.37	6.32	6.32	142	PRB12-15
2.00	3.00	3.250	3.125	.54	1.00	4.37	6.32	6.32	220	PRB12-20
3.00	4.00	4.000	3.250	.53	1.00	4.37	6.32	6.32	264	PRB12-30
1.00	2.00	1.375	1.500	.62	1.50	6.25	6.32	6.32	132	PRB15-10
2.00	3.00	2.375	2.500	.62	1.50	6.25	6.32	6.32	176	PRB15-20
3.00	4.00	3.375	3.500	.62	1.50	6.25	6.32	6.32	176	PRB15-30
4.00	5.00	4.375	4.000	.62	1.50	6.25	6.32	6.32	308	PRB15-40
1.00	2.00	1.375	1.525	.75	1.75	8.75	6.32	6.32	142	PRB2-10
2.00	3.25	2.625	2.150	.75	1.75	8.75	6.32	6.32	176	PRB2-20
3.00	4.00	3.375	3.075	.75	1.75	8.75	6.32	6.32	176	PRB2-30
4.00	5.00	4.375	4.025	.75	1.75	8.75	6.32	6.32	308	PRB2-40
1.00	2.00	1.625	1.875	1.00	2.50	12.50	10.32	10.32	251	PRB3-15
2.00	4.00	3.000	3.375	1.00	2.50	12.50	10.32	10.32	352	PRB3-20
3.00	5.00	4.000	4.375	1.00	2.50	12.50	10.32	10.32	440	PRB3-30
4.00	6.00	5.000	5.375	1.00	2.50	12.50	10.32	10.32	440	PRB3-40

*Maximum center-to-center mounting hole spacing. (Type 20 and 30 are 1/8" lead and 1/4" lead)

RAILS

Application

Bearings are normally supplied and installed in sets of two to form an assembly that can support their rated load in any direction or orientation, and can be preloaded to eliminate side play.

Mounting and banking surfaces must be smooth and flat, and accurately parallel, coplanar, or perpendicular, respectively, to achieve maximum accuracy. Preload forces must be evenly distributed. Dirt and dust must be excluded. Lubrication required depends on the application, ranging from light grease or oil at the time of installation for low speeds (less than 50 inches/min) and occasional movement to continuous oil bath or mist at 1200 inches/min.

Construction

Each bearing consists of a pair of hardened steel ways containing 90° vee grooves, and a row of alternately crossed cylindrical rollers. The hardened steel rollers are captive in a cage for easy handling and assembly and permanent alignment. The ways are installed face to face by the user, with the rollers between the vee grooves.

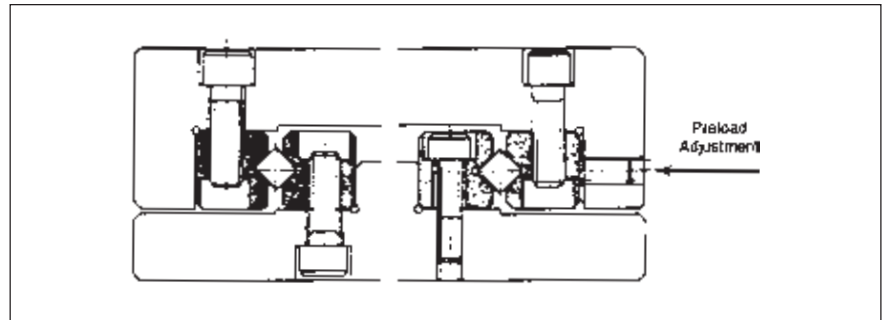

Mounting holes in the way bars are threaded, and also counter-bored to alternatively permit using the next smaller size screw with threaded mounting holes in the user's components.

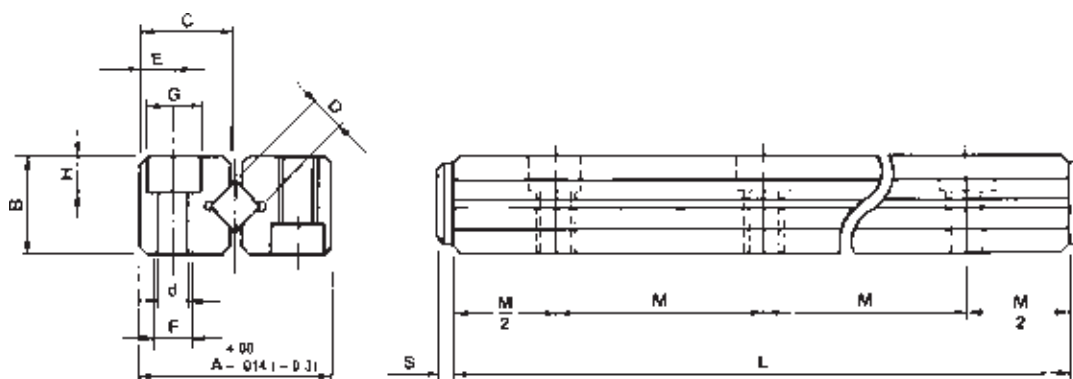

Specifications
 Maximum deviation from parallelism between vee groove face and datum face for each way bar is 200 micro inches.
 Rails: Hardened Steel
 Rollers: Hardened Steel

NOTE: Each set contains 4-V grooved rails with end screws and 2-roller cages with captive rollers.

Length, Travel, and Load Selection

Travel T	Length L	No. Rollers in Each Retainer	No. Holes	Rail Set Load Cap. (lbs.)	Part No.
473 (12)	788 (20)	5	2	33	PNB1-020
789 (20)	1181 (30)	7	3	61	PNB1-030
1063 (27)	1575 (40)	10	4	88	PNB1-040
1260 (32)	1969 (50)	13	5	114	PNB1-050
1709 (43)	1181 (30)	5	2	66	PNB2-030
915 (23)	1772 (45)	8	3	105	PNB2-045
1121 (29)	2362 (60)	11	4	145	PNB2-060
1732 (44)	2953 (75)	13	5	171	PNB2-075
1107 (28)	1969 (50)	7	2	154	PNB3-050
1630 (42)	2953 (75)	10	3	220	PNB3-075
2263 (58)	3937 (100)	14	4	308	PNB3-100
3071 (78)	4921 (125)	17	5	374	PNB3-125
3464 (88)	5906 (150)	21	6	462	PNB3-150
2783 (71)	3150 (80)	7	2	408	PNB4-080
3226 (82)	4725 (120)	11	3	484	PNB4-120
4134 (105)	6299 (160)	15	4	660	PNB4-160
2165 (55)	3937 (100)	8	2	704	PNB6-100
3346 (85)	5906 (150)	12	3	1056	PNB6-150
4724 (120)	7874 (200)	16	4	1408	PNB6-200
7283 (185)	11811 (300)	24	6	2112	PNB6-300
9646 (245)	15748 (400)	32	8	2816	PNB6-400

Profile and Mounting Dimensions

A	B	C	D	S	M	E	F	J	d	G	H	Series
335 (8.5)	158 (4.0)	154 (3.9)	359 (9.1)	659 (16.8)	394 (10)	371 (9.4)	M2	± 0	365 (9.3)	118 (3.0)	655 (16.7)	PNB1-000
473 (12)	236 (6.0)	217 (5.5)	379 (9.6)	979 (24.9)	591 (15)	568 (14.5)	M3	± 0	500 (12.7)	173 (4.4)	979 (24.9)	PNB2-000
705 (18)	315 (8.0)	327 (8.3)	418 (10.6)	1292 (32.8)	984 (25)	938 (23.9)	M4	± 4	750 (19.3)	236 (6.0)	1223 (31)	PNB3-000
865 (22)	433 (11)	432 (11.0)	538 (13.7)	1729 (44.2)	1575 (40)	1478 (37.5)	M5	± 8	889 (22.6)	315 (8.0)	1657 (42)	PNB4-000
1221 (31)	591 (15)	559 (14.2)	736 (18.8)	2363 (60)	2985 (76)	2263 (58)	M5	± 10	205 (5.2)	374 (9.5)	2363 (60)	PNB6-000

Measurement in inches (mm)

BALL SLIDE GUIDES

Compact Design

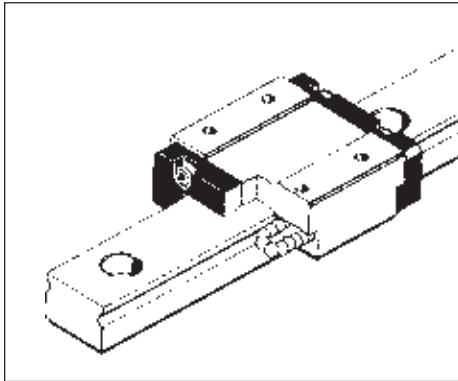

SEB (Ball type) — Low Price / High Speed

The SEB type slide guide consists of a block and a guide rail, both of which have two precision-ground, R-shaped raceway grooves. Steel balls recirculate in each raceway groove while they make 4 point contact. The block consists of a main body with raceway grooves and a pair of resin return caps for smooth circulation of steel balls.

- Smooth and stable operation.
- Compact, lightweight and low price.
- High load capacity by the use of Gothic arch grooves.
- Four-point contact to carry load and moment in all directions.
- Dust protection wiper as standard.
- Extra wide type also available.
- For higher accuracy and rigidity, a crossed roller version is available.
- All stainless steel version available — consult factory

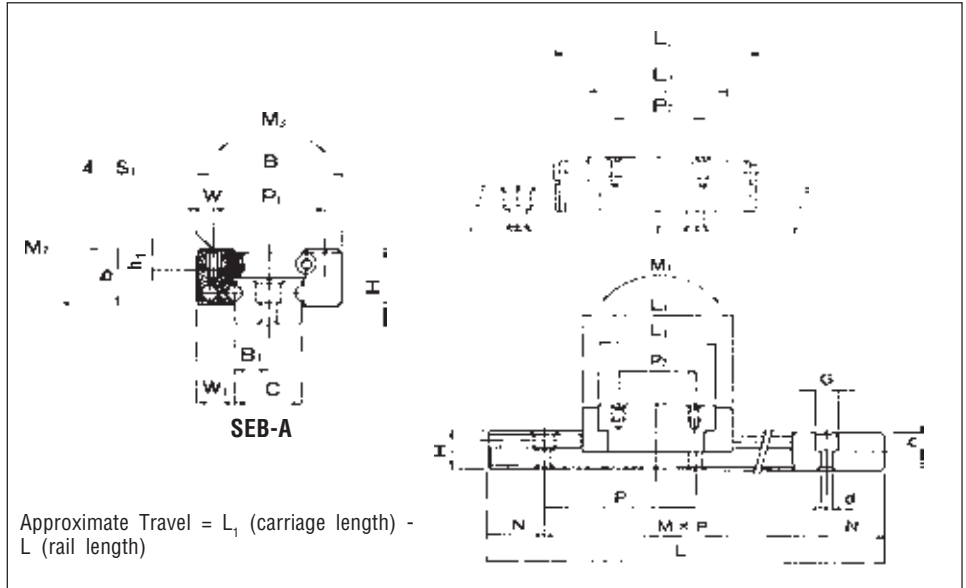

Ordering Information

Order standard ball slide guides from table by model number. Include the number of slide units required on one rail and the guides rail length in mm.

EXAMPLE: SEB12 U — 1 — 370

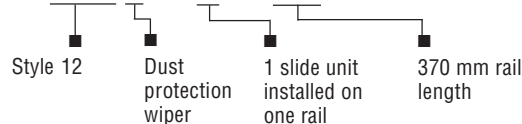

Style	Dimensions Of Carriage											Basic Load Rating		Dimensions Of Guide Rail (Metric)						
	H	B	Wiper L ₂	L ₁	W	P ₁	P ₂	S ₁	h ₁	L ₃	b	C lbf (CN)	Co lbf (CON)	H ₁	C	B ₁	W ₁	d x G x h	N	
SEB 2U**	.126 (3.2)	.236 (6)	.563 (14.3)	.508 (12.9)		—	.157 (4)	M1.4	—	.366 (9.3)	.098 (2.5)	47 (210)	85 (380)	.079 (2)	.079 (2)	—	—	—	(4)	
SEB 3U**	.157 (4)	.315 (8)	.465 (11.8)	.413 (10.5)		—	.138 (3.5)	M1.6	—	.256 (6.5)	.118 (3)	56 (250)	81 (360)	.102 (2.6)	.118 (3)	—	—	—	(5)	
SEB 5U**	.236 (6)	.472 (12)	.669 (17)	.614 (15.6)	.079 (2)	.315 (8)	—	M2	.059 (1.5)	.386 (9.8)	.177 (4.5)	96 (430)	160 (715)	.157 (4)	.197 (5)	.098 (2.5)	.138 (3.5)	.094 x .138 x .039 (2.4 x 3.5 x 1)	.197 (5)	
SEB 7U**	.315 (8)	.669 (17)	.925 (23.5)	.862 (21.9)	.098 (2.5)	.472 (12)	.318 (8)	M2	.098 (2.5)	.594 (15.1)	.256 (6.5)	242 (1080)	375 (1670)	.185 (4.7)	.276 (7)	.138 (3.5)	.197 (5)	.094 x .165 x .091 (2.4 x 4.2 x 2.3)	.197 (5)	
SEB 9U	.394 (10)	.787 (20)	1.20 (30.5)	1.106 (28.1)	.098 (2.5)	.591 (15)	.394 (10)	M3	.118 (3)	.803 (20.4)	.307 (7.8)	375 (1670)	551 (2450)	.217 (5.5)	.354 (9)	.177 (4.5)	.217 (5.5)	.138 x .236 x .138 (3.5 x 6 x 3.5)	.295 (7.5)	
SEB 12U	.512 (13)	1.063 (27)	1.339 (34)	1.181 (30)	.138 (3.5)	.787 (20)	.591 (15)	M3	.138 (3.5)	.906 (23)	.394 (10)	485 (2160)	706 (3140)	.295 (7.5)	.472 (12)	.236 (6)	.295 (7.5)	.138 x .236 x .177 (3.5 x 6 x 4.5)	.394 (10)	
SEB 15U	.630 (16)	1.260 (32)	1.673 (42.5)	1.516 (38.5)	.138 (3.5)	.984 (25)	.788 (20)	M3	.157 (4)	1.161 (29.5)	.472 (12)	816 (3630)	1212 (5390)	.374 (9.5)	.591 (15)	.295 (7.5)	.335 (8.5)	.138 x .236 x .177 (3.5 x 6 x 4.5)	.591 (15)	
SEB 20U	.984 (25)	1.811 (46)	2.441 (62)	2.193 (55.7)	.157 (4)	1.496 (38)	1.496 (38)	M4	.236 (6)	1.709 (45.7)	.689 (17.5)	1542 (6860)	2203 (9800)	.591 (15)	.787 (20)	.394 (10)	.512 (13)	.236 x .374 x .335 (6 x 9.5 x 8.5)	.788 (20)	

Measurements in inches (mm)

This table is continued...

Note: Inch conversion to mm: 25.4 x Inch

* Rail is tapped for SEB2 & SEB3 Series. SEB2 - M1 / SEB3 - M1.6

** Rail Mounting screws supplied with rails for SEB5 - M2 x .4 x 6 Phillips head

• Stainless Steel

Specifications:

Accuracy (See Figure 1):

	Inches	(mm)
Height H tolerance	0.0008	(0.020)
Height H pair variation	0.0006	(0.015)
Width W ₁ tolerance	0.001	(0.025)
Width W ₁ pair variation	0.0008	(0.020)

Temperature:

Ambient temperatures up to 100°C (212°F) maximum.

Running Parallelism:

Surface C to Surface A See Figure 2
Surface D to Surface B See Figure 2

Load Ratings:

In applications involving high impact or speeds in excess of 2400"/min., divide the rated load rating by a factor of 3.

Preload:

Factory set preload ensures high rigidity.

Materials:

Roller rails and slide-block are made of 52100 chrome steel

- Stainless Steel (SEB 2,3,5&7)

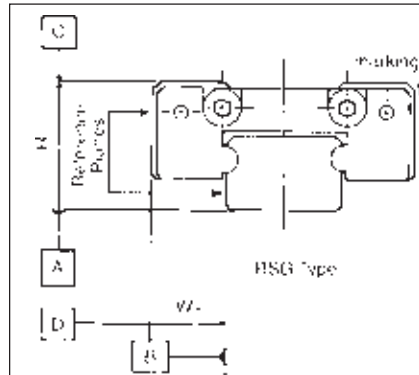

Figure 1.

Figure 2.

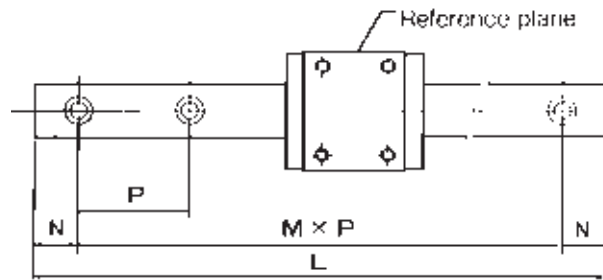
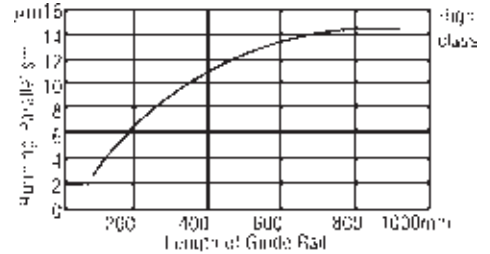

Figure 3. Special length guide rails

Special-Length Guide Rails

For the SEB and SER types, special-length guide rails are also available, within the maximum length of the standard product. If the n1 and n2 dimensions shown in Figure 3 are not specified, such rails are manufactured within the standard dimension range.

Lubrication and Dust Prevention

The slide guides are shipped lubricated with sealed quality lithium soap base lubricant and can be used directly. The guides are standard with a wiper to prevent contamination.

Guide Rail Lengths (Metric)											Allowable Static Moments			Weight (Metric)		Style		
Length			Length			Length			Length			P	M ₁	M ₂	M ₃		Carriage lb (kg)	Guide Rail lb/ft (kg/m)
L _{in.}	(L _{mm})	[M]	L _{in.}	(L _{mm})	[M]	L _{in.}	(L _{mm})	[M]	L _{in.}	(L _{mm})	[M]		LB-IN	LB-IN	LB-IN			
1.260 4.094	(32) (104)	[3] [12]	1.575 (40)	[4]	2.205 (56)	[6]	3.150 (80)	[9]	(8)	4.6	5.6	3.6	.002 (.0008)	.018 (.028)	SEB 2U*•			
1.181 3.937	(30) (100)	[2] [9]	1.575 (40)	[3]	2.362 (60)	[5]	3.150 (80)	[7]	(10)	3.4	4	5	.002 (.001)	.033 (.05)	SEB 3U*•			
1.575 5.118	(40) (130)	[2] [8]	2.165 (55)	[3] [10]	2.756 (70)	[4]	3.937 (100)	[6]	.591 (15)	11	13	18	.006 (.003)	.087 (.13)	SEB 5U***			
1.575 3.937	(40) (100)	[2] [6]	2.165 (55)	[3] [8]	2.756 (70)	[4]	3.346 (85)	[5]	.591 (15)	27	32	46	.022 (0.01)	.128 (0.19)	SEB 7U***			
2.165 6.102	(55) (155)	[2] [7]	2.953 (75)	[3] [9]	3.740 (95)	[4] [13]	4.528 (115)	[5]	.788 (20)	67	80	101	.044 (0.02)	.208 (0.31)	SEB 9U			
4.724 12.598	(120) (320)	[4] [12]	6.693 (170)	[6] [14]	8.661 (220)	[8] [18]	10.630 (270)	[10]	.984 (25)	92	109	177	.088 (0.04)	.410 (0.61)	SEB 12U			
5.906 21.652	(150) (550)	[3] [13]	9.055 (230)	[5] [16]	12.205 (310)	[7]	16.929 (430)	[10]	1.575 (40)	191	225	356	.132 (0.06)	.685 (1.02)	SEB 15U			
8.661 25.197	(220) (640)	[3] [10]	11.024 (280)	[4] [14]	13.386 (340)	[5]	18.110 (460)	[7]	2.362 (60)	451	538	868	.507 (0.23)	1.438 (2.14)	SEB 20U			

... on this page.

X-XY-XYZ POSITIONERS WITH MICROMETERS

Profile Dimensions



“X-Y”

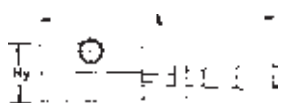

“X-Y-Z”



Carriage Mounting Dimensions



Series	C	D	E	F	N
101	1.00	1.00	.69	.50	.69
201	1.50	1.50	1.19	1.00	1.19

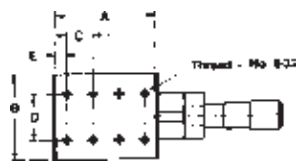

Series	C	D	E	No. Holes
400	.50	.875	.25	8
500	.55	.875	.25	12

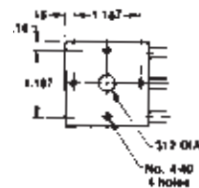

Series 300

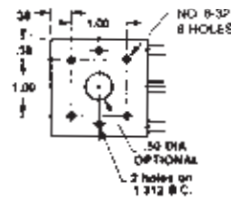

Series 450



Series	C	D
1200	2.625	2.125
2200	3.625	3.125

Optional Carriage Positional Lock



See Note 3 Below

Series	K Nominal
P100	1.265
P200	
P1200	1.750
P2200	2.250
P400	2.390
P300	2.395
P450	
P500	2.390

Specifications

Straight line accuracy: .0005/inch of travel

Material: Aluminum Base and Carriage

Repeatability: .0001

Finish: Black Anodize

Drive: Micrometer .001 graduations standard

.01 mm graduations optional

Travel T	A	B	L	Base Mounting M	H	Hx	Hy	J	K	Load Capacity (lbs.)		Part No.*
										X, XY	Z	
.50	1.25	1.25	3.25	1.00	# 2	.38	.75	.62	.38	4	1.25	P101-
.50	1.75	1.75	3.75	1.50	# 2	.38	.75	.62	.44	4	1.25	P201-
.50	1.50	1.50	3.50	1.187	# 4	.62	1.25	1.62	.32	12	2	P301-
.50 (13mm)	2.00	1.75	4.62	1.62	# 6	.75	1.69	.50	1.12	20	2	P401-
.50 (13mm)	1.75	1.75	4.38	1.312	# 6	.75	1.50	2.00	Flush	20	2	P450-
1.00 (25mm)	1.75	1.75	5.88	1.312	# 6	.75	1.50	2.00	Flush	20	2	P451-
.50 (13mm)	3.25	1.75	5.88	2.75	# 6	.75	1.69	.56	Flush	42	20	P501-
1.00 (25mm)	3.25	1.75	7.41	2.75	# 6	.75	1.69	1.56	Flush	42	20	P502-
1.00 (25mm)	3.12	3.12	7.25	2.625	#10	.88	1.76	2.50	.50	30	30	P1201-
1.00 (25mm)	4.12	4.12	8.38	3.625	#10	.88	1.76	2.75	.56	30	30	P2201-
.50	1.50	1.50	3.50	1.187	# 4	.62	1.25	.44	1.00	-	2	P301LP-*
.50 (13mm)	1.75	1.75	4.38	1.312	# 6	.75	1.50	.69	1.12	-	2	P450LP-*
1.00 (25mm)	1.75	1.75	5.88	1.312	# 6	.75	1.50	.69	1.12	-	2	P451LP-*

* To order any positioner, please follow these directions with the appropriate series.

1. Add "M" for Metric Micrometer.
2. Designate axis desired as follows:
X, XY, or XYZ
3. For optional lock substitute L for dash (-) in part number

Example: P101-X
P101-XYZ
P401-XY
P401M-XY

Example: P101LX

** LP indicates low profile for XYZ only.

Micrometer Locking Device Available —Consult Factory

LEAD SCREWS & NUTS

A Range Of Styles / Inch And Metric Sizes

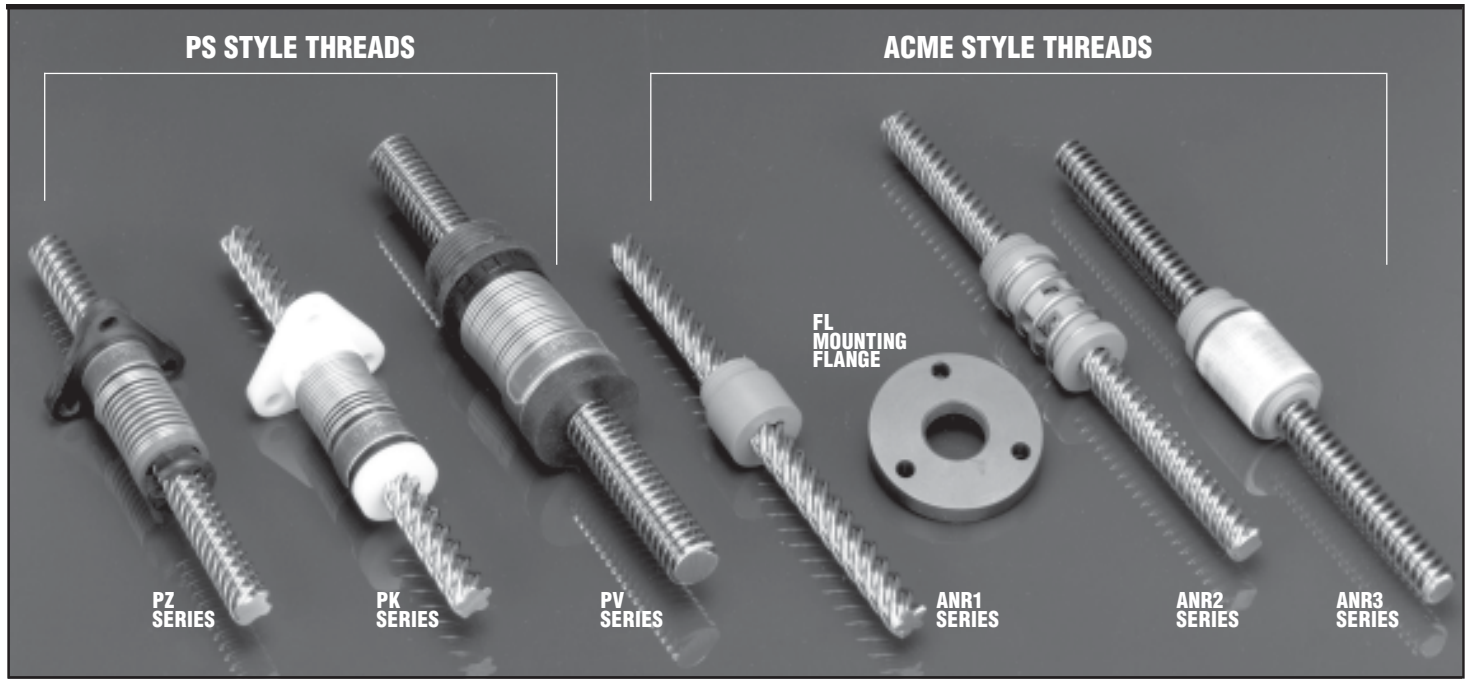

PIC Design has significantly increased its range of lead screws and nuts to provide users with the most complete line in the industry. Designers are no longer confined to the original Acme lead screws ... the new and innovative PS Series employs a modified thread form that is designed for maximum life and quiet operation when used in conjunction with the patented anti-backlash nuts.

PIC DESIGN LEAD SCREWS

Lead screws provide an economical solution for the transfer of rotary motion to linear motion. All PIC Design lead screws are precision rolled from 303 stainless steel with a lead accuracy of .0006 in/in (mm/mm). They are stocked in both inch and metric sizes with diameters that range from $3/16$ " to $3/4$ ". Lengths are available up to six feet.

The now familiar precision rolled Acme lead screws are available with the above noted accuracy when used with Turcite X (Acetal-Teflon and Silicone filled) nuts.

The new PS style lead screws have accuracies similar to that of the Acme line, but feature a positional repeatability to within 50 micro-inches. These lead screws feature a burnished finish of 16 micro-inches, and a straightness of .003 in/ft.

PS style lead screws are available uncoated or coated with a custom composition of baked-on Teflon. This coating greatly improves lubricity and extends the normal life of the assembly by as much as 300%.

PS STYLE THREADS Anti-Backlash Nuts

The standard method for taking up backlash is to bias two nut halves axially using a type of compliant spring. Using this method, the spring force must be at least as great as the load to be moved.

The new PS style lead screws use a patented axial take-up mechanism, which effectively puts a stiff spacer between the nut halves. By using this design, the nut functions independently of the load, resulting in a low drag torque. Nuts are a self-lubricating polyacetal material.

PZ Series anti-backlash nuts are ideal for vertical applications requiring noise and vibration control. This series accommodates lead screws with moderate loads, and diameters from $1/4$ " to $1/2$ ".

PK Series anti-backlash nuts are very low in frictional drag and are specifically designed for $3/8$ " diameter lead screws.

PV Series anti-backlash nuts provide the maximum load carrying capability and the lightest axial and radial stiffness. This results in smooth, quiet operation, and long life. The PV series is best suited for higher loads, and is thus used on PIC's largest lead screws with $1/2$ " and $3/4$ " diameters.

ACME STYLE THREADS

FL
MOUNTING
FLANGE

ACME STYLE THREADS Power And Anti-Backlash Nuts

PIC Design offers three Turcite X nuts that are compatible with Acme style lead screws. Each nut offers distinct advantages.

ANR1 Series power nuts are used where a range of .003" to .007" axial backlash can satisfy user requirements. The ANR1 is the most economical.

ANR2 Series anti-backlash nuts are designed for applications requiring positional accuracy and repeatability. The ANR2 anti-backlash nut assembly consists of two halves with an axially compliant spring that provides some ability to fine tune preload. The spring preload on the nut must be approximately 5% greater than the axial load on the system.

ANR3 Series anti-backlash nuts are designed to be adjusted. An "O" ring spacer is placed between the two halves of the nut. The back half of the nut is adjusted by simply turning the outside body until desired preload is obtained. The "O" ring provides for minor screw thread deviations. ANR3 series nuts can be used for higher loads than the ANR2 series.

BALL SCREWS & NUTS

See the complete line of B style precision rolled ball screws & nuts starting on page 3-15.

TECHNICAL SECTION

Lead Screw Assembly

TERMINOLOGY

The glossary of terms and basic formulas presented below will aid designers in evaluating system requirements. Critical system parameters such as torque, efficiency, maximum load and critical speed are easily evaluated.

- **Lead Screw Assembly:** A screw and nut device used for the purpose of transmitting motion or power as opposed to fastening.
- **Backlash:** Free axial movement between screw and nut.
- **Column Strength:** Maximum compressive load that can be applied to a shaft without taking a permanent set.
- **Critical Speed:** Operating speed of spinning shaft that develops severe vibrations during rotation. This is a function of length, diameter and end supports.
- **Drag Torque:** The torque necessary to drive the lead screw assembly alone.
- **Efficiency:** Ratio of work output to work input; varies with lead, thread angle and coefficient of friction (see screw data).
- **Lead:** Distance traveled by the nut in one revolution (equal to the screw pitch x the number of starts).
- **Lead Angle:** The angle made by the helix of the thread at the screw pitch line with plane perpendicular to the screw axis.
- **Major Diameter:** The diameter of a cylinder formed by the crests of the thread.
- **Minor Diameter:** The root diameter.
- **Pitch:** The distance as measured parallel to the thread axis between corresponding points on adjacent thread forms, generally equal to the lead divided by the number of starts.
- **Self Locking:** When it is impossible for a thrust load on a nut to create a torque on its screw, the screw and nut are said to be self-locking. A self-locking screw will not convert thrust to torque. Generally, Acme screws are self-locking while most high lead and ball screw are non self-locking. A non self-locking screw will require a mechanical brake or some other locking means to sustain a load.
- **Stroke:** The axial distance traveled by the nut in either direction.
- **Thread per inch:** The reciprocal of the pitch is the number of threads per inch.

The application engineering information in this section should enable the designer to fully evaluate the lead screws offered in this catalog.

CRITICAL SPEED / ANGULAR VELOCITY

When a shaft is spinning, as in the case of an operating Lead screw, it will experience excessive vibration at a speed approximating its natural frequency of vibration. This speed is called the "Critical Speed" and good design practice dictates that speed should be limited to 85% of a shaft's first order critical speed. Critical speed is a function of shaft diameter, end support configuration and unsupported length. These speeds are shown in graphic form for various shaft diameters, lengths and supports.

COLUMN STRENGTH / COMPRESSION LOAD

Under compressive loading a sufficiently slender shaft will fail by elastic instability at a load well below the shaft's elastic limit or rated load. A graph is provided to show the maximum safe column load for various diameters, lengths and supports. Shaft slenderness ratios exceeding 200 are not recommended and the curves are dotted for these ratios. Column strength limitations do not apply to shafts under tension loads.

TORQUE, ROTARY TO LINEAR (Torque needed to move load)

$$\text{Torque (in. lbs.)} = \frac{\text{Load (lbs.)} \times \text{Lead (inches)}}{2\pi \times \text{efficiency}}$$

TORQUE, LINEAR TO ROTARY (Backdriving Torque)

$$\text{Torque to hold load} = \frac{\text{Load} \times \text{Lead} \times \text{Efficiency}}{2\pi}$$

If greater than 1 may backdrive*

FORWARD DRIVING EFFICIENCY (See screw data)

$$E_F = (\tan \lambda) [(\cos \Phi_n - f \tan \lambda) / (\cos \Phi_n \tan \lambda + f)]$$

BACKWARD DRIVING EFFICIENCY

$$E_B = (1/\tan \lambda) [(\cos \Phi_n \tan \lambda - f) / (\cos \Phi_n + f \tan \lambda)]$$
$$= \frac{\text{Load} \times \text{Lead} \times \text{Efficiency}}{2\pi}$$

f = Coefficient of friction

E_B = Back drive efficiency

E_F = Forward drive efficiency

λ = Thread lead angle

Φ_n = Thread angle in normal plane. (29° for ACME Thread, 30° for Metric Trapezoidal, 40° for Precision PS Series.)

SCREW RPM

$$\text{RPM} = \frac{\text{Velocity (in/min)}}{\text{Lead (in/rev)}}$$

COLUMN LOAD STRENGTH (Based on Eulers Formula)

$$P_{Cr} = \frac{14.03 \times 10^6 F_c d^4}{L^2}$$

P_{Cr} = maximum load (lbs.)

F_c = end support factor (see page 3-3)

= .25 one end fixed, other free

= 1.00 both ends supported

= 2.00 one end fixed, other supported

= 4.00 both ends fixed

d = root diameter of screw (inches)

L = maximum distance between nut & load carrying bearing (inches)

When possible, design for tension loads to eliminate the buckling factor and reduce the required screw size.

CRITICAL SCREW SHAFT SPEED

(Maximum rotational speed of a screw)

$$C_s = F \times 4.76 \times 10^6 \times \frac{d}{L^2}$$

C_s = Critical speed (RPM)

d = root diameter of screw (inches)

L = Length between supports (inches)

F = end support factor (see page 3-3)

.36 one end fixed, other free

1.00 simple supports both ends

1.47 one end fixed, one simple

2.23 both ends fixed

Critical shaft speed should be reduced to 85% to allow for other factors such as alignment and straightness.

* If the lead is greater than 1/3 of the diameter, it may backdrive

TECHNICAL SECTION

Critical Speed and Compression Load Determination

CRITICAL LEAD SCREW SPEED vs. LEAD SCREW LENGTH

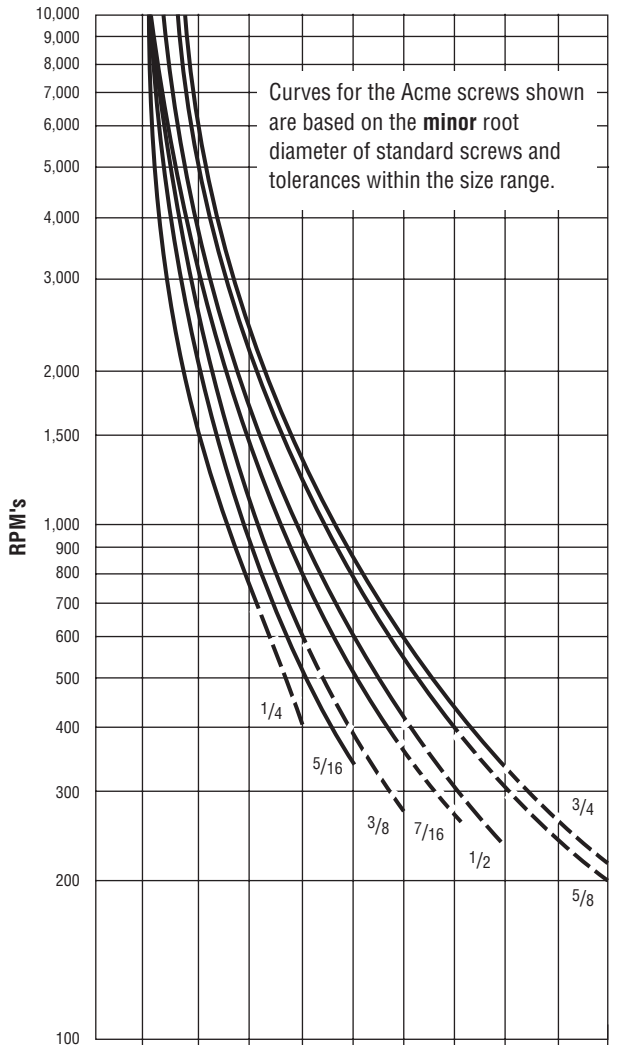

A Fixed-Free	6	12	18	24	30	36	42	48	54	60
B Simple-Simple	10	20	30	40	50	60	70	80	90	100
C Fixed-Simple	12	24	36	48	61	73	85	97	109	121
D Fixed-Fixed	15	30	45	60	75	90	105	119	134	149

Maximum Length Between Bearings (Inches)

MAXIMUM COMPRESSION LOAD vs. LEAD SCREW LENGTH

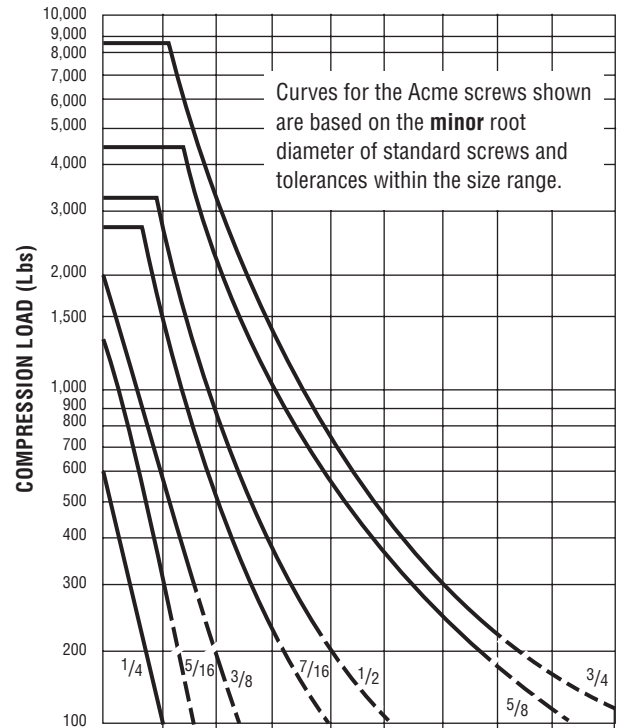

A Fixed-Free	5	10	15	20	25	30	35	40	45
B Simple-Simple	10	20	30	40	50	60	70	80	90
C Fixed-Simple	14	28	42	57	71	85	99	113	127
D Fixed-Fixed	20	40	60	80	100	120	140	160	180

Maximum Length Between Bearings (Inches)

ASCERTAINING COMPRESSION LOADS

Use procedure similar to that for finding critical shaft speed

END SUPPORT CONFIGURATIONS

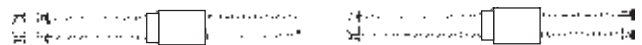

A Fixed-Free

B Simple-Simple



C Fixed-Simple

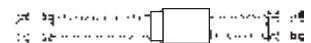

D Fixed-Fixed

ASCERTAINING CRITICAL SHAFT SPEED

1. Examine the drawings to the right and determine the type of lead screw end support bearing employed — A, B, C or D.
2. Determine the maximum length between end supports. Locate that number, in the table above, opposite the appropriate end support.
3. Locate the vertical line on the graph that matches the number in step 2. Where this line intersects the appropriate diameter lead screw curve, determine critical shaft speed. PIC Design recommends operating at a speed less than 85% of this number in order to allow for any misalignments.

TECHNICAL SECTION

Axial Take-Up Mechanisms

TYPICAL SOLUTIONS —

Backlash Compensation Without High Drag Torque

The standard method for taking up backlash is to bias two nut halves axially using some type of compliant spring. (Wavy washer, compression spring, rubber washer, etc.)

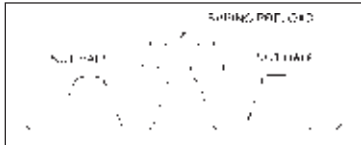

The unit is very stiff in the direction in which the nut half is loaded against the flank of the screw thread. However, in the direction away from the screw thread, the nut is only as axially stiff as the amount of preload which the spring exerts.

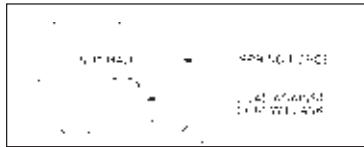

For example, if the maximum axial load which the system is

subjected to is 50 lbs., the amount of spring preload must be equal to or greater than 50 lbs. in order to maintain intimate screw/nut contact. The problems arising from preloading in this manner are increased torque and nut wear.

An alternate method would thus be to replace the spring with a stiff spacer sized to fit exactly between the two nut halves.

There would then be no excessive preload force at the interface and the unit would be capable of carrying high axial loads in either direction with no backlash.

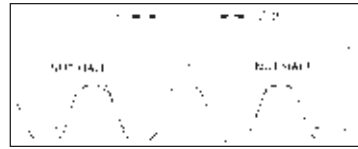
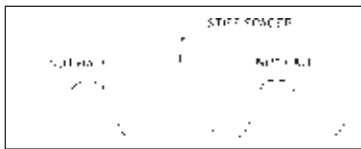

This is fine initially. However, as use time increases, wear begins on the nut threads causing a gap to develop between the spacer (L) and the nut halves.

This gap ($\Delta 1 + \Delta 2$) is now the amount of backlash which has developed in the unit. This backlash can be removed by replacing the stiff spacer with a new spacer equal to $(L + \Delta 1 + \Delta 2)$. This process, although effective, would be extremely costly and difficult to implement on a continuous basis.

A PATENTED SOLUTION

What is needed, then, is a stiff spacer which will continually expand to accommodate the wear which occurs during use.

This is done by creating a spacer threaded at one end with a complimentary nut torsionally biased to advance when a gap develops.

The thread at the end of the spacer is a fine helix such that an axial load will not backdrive the nut once spacer growth has occurred.

The amount of preload on the unit is only that necessary to turn the spacer nut on the spacer rod and is independent of the external system loadings. THIS PATENTED

DESIGN HAS A SELF-WEAR COMPENSATING UNIT WHICH HAS EXTREMELY LOW FRICTIONAL DRAG TORQUE YET HIGH AXIAL STIFFNESS.



JOURNAL/END MACHINING & MOUNTING ACCESORIES

For Use With Series S10 and S12 Blocks

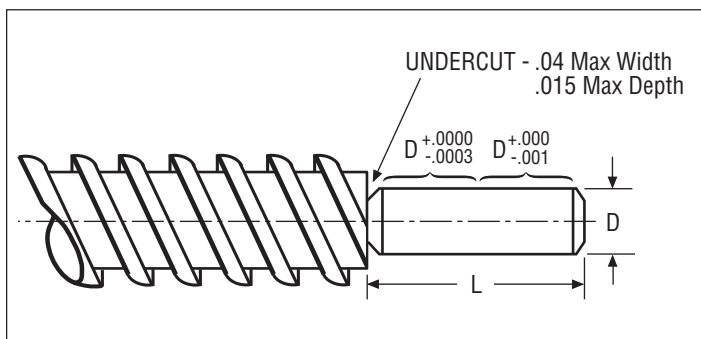

End Machining

Available at an additional cost. PIC offers a typical journal for use with a bearing/mount support. Custom end machining available. Send drawing with your RFQ.

Please Note:

- Bearing Shaft Spacers are listed in Catalog Section 6
- Couplings are listed in Catalog Section 7
- Linear Bearings and Shafting are listed in Catalog Section 4

The data presented below will be useful when designing lead screw systems using Series S10 Universal Bearing Blocks and Series S12 Bearing Blocks.

When Using Series S10 Universal Bearing Blocks

Screw Dia.	D		Ball Bearing	Retaining Ring	Shim Pack	Shaft Collar
	Journal Dia.	Journal Length				
3/16	0.1247	1.00	E1-3	Z1-1	SP-06	C1-1
1/4	0.1247	1.00	E1-3	Z1-1	SP-06	C1-1
5/16	0.1872	1.12	E1-8	Z1-2	SP-08	C1-2
3/8	0.2497	1.12	E1-9	Z1-3	SP-10	C1-3
7/16	0.2497	1.12	E1-9	Z1-3	SP-10	C1-3
1/2	0.3747	1.38	E1-15	Z1-5	SP-14	C1-10
5/8	0.3747	1.38	E1-15	Z1-5	SP-14	C1-10

When Using Series S12 Bearing Blocks

Screw Dia.	D		Flange Adaptor	Flange Spacer	Flanged Ball Bearing	Bearing Housing
	Journal Dia.	Journal Length				
3/16	0.1247	0.6	LMB-4		E2-3	S12-4
1/4	0.1247	0.6	LMB-4		E2-3	S12-4
5/16	0.1872	0.75	LMB-6		E2-6	S12-5
3/8	0.2497	0.813	LMB-6		E2-9	S12-8
7/16	0.2497	0.813	LMB-8		E2-9	S12-8
1/2	0.2497	0.813	LMB-8	SMB-8	E2-9	S12-8
5/8	0.3747	1.083	LMB-10	SMB-10	E2-15	S12-10

PRECISION PS STYLE LEAD SCREWS

For use with PZ, PK and PV Style Nuts

.0006 Inch/Inch (mm/mm) Lead Accuracy

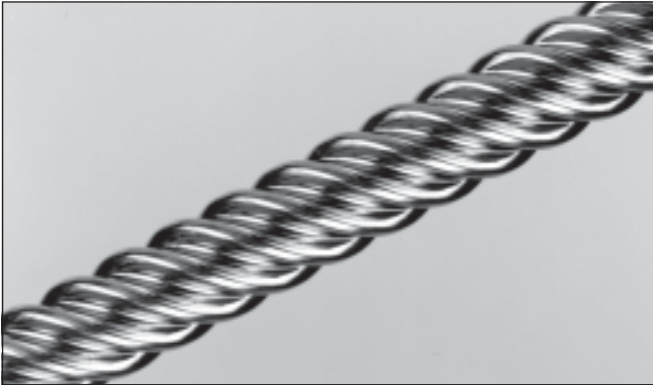

Material: 303 Stainless Steel

Repeatability: .000050 inches

System (lead screw and nut) Specification

Operating Temperature Range: 32°F - 200°F (0°C - 93°C)
 Coefficient Of Friction (Nut To Screw): .08 Static
 .15 Dynamic
 (.09 when TFE coated)

Features:

- Precision rolled
- Lead screw accuracy of .0006 in./in. (mm/mm)
- Straightness tolerance of .003 in/ft.
- Screws have burnished finish of better than 16 micro-inch due to the rolling process
- 303 Stainless steel used for uniform grain structure to improve lead accuracy
- Available with custom TFE coating to extend normal life in as much as 300%

Part Number

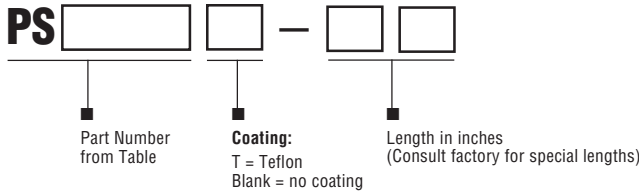

Screw Dia.	Lead (in. or mm)	Root Dia. in. (mm)	Efficiency EF (%)	Standard Length (in.)	** Part No.
1/4	0.062	0.170	52	12, 36, 72	PS4006 <input type="checkbox"/> - <input type="checkbox"/>
	0.250	0.168	79		PS4025 <input type="checkbox"/> - <input type="checkbox"/>
	1.000	0.170	84		PS4100 <input type="checkbox"/> - <input type="checkbox"/>
	1.5 mm	0.172 (4.37)	51		PS4M01.5 <input type="checkbox"/> - <input type="checkbox"/>
3/8	0.100	0.266	53	12, 36, 72	PS6010 <input type="checkbox"/> - <input type="checkbox"/> *
	0.200	0.266	69		PS6020 <input type="checkbox"/> - <input type="checkbox"/>
	0.300	0.255	76		PS6030 <input type="checkbox"/> - <input type="checkbox"/>
	0.500	0.265	81		PS6050 <input type="checkbox"/> - <input type="checkbox"/> *
	1.000	0.254	84		PS6100 <input type="checkbox"/> - <input type="checkbox"/>
	1.200	0.254	84		PS6120 <input type="checkbox"/> - <input type="checkbox"/>
	2 mm	0.254 (6.45)	47		PS6M02 <input type="checkbox"/> - <input type="checkbox"/>
5 mm	0.266 (6.76)	69	PS6M05 <input type="checkbox"/> - <input type="checkbox"/>		
7/16	0.250	0.325	70	24, 48, 72	PS7025 <input type="checkbox"/> - <input type="checkbox"/>
	0.500	0.328	80		PS7050 <input type="checkbox"/> - <input type="checkbox"/>
	3 mm	0.363 (9.22)	52		PS7M03 <input type="checkbox"/> - <input type="checkbox"/>
	5 mm	0.313 (7.95)	65		PS7M05 <input type="checkbox"/> - <input type="checkbox"/>
1/2	0.050	0.433	28	24, 48, 72	PS8005 <input type="checkbox"/> - <input type="checkbox"/>
	0.100	0.364	46		PS8010 <input type="checkbox"/> - <input type="checkbox"/> *
	0.200	0.366	63		PS8020 <input type="checkbox"/> - <input type="checkbox"/> *
	0.500	0.352	79		PS8050 <input type="checkbox"/> - <input type="checkbox"/>
	1.000	0.372	84		PS8100 <input type="checkbox"/> - <input type="checkbox"/> *
3/4	1.000	0.619	81	24, 48, 72	PS12100 <input type="checkbox"/> - <input type="checkbox"/> *
	2.000	0.611	84		PS12200 <input type="checkbox"/> - <input type="checkbox"/>

NOTES: When Teflon coating is used, do not use lubrication. Random voids in the teflon coating have no effect on system performance. The lubricant, although solid, has some "spreading" ability as in fluid lubricants. Uncoated screws should not require lubrication. For those instances where lubrication may be desired, a silicone or lithium-based lubricant is suggested.

* Left hand thread available.
 ** For Teflon coating insert a T before dash.
 For Example: PS4006T - 72

PZ STYLE LEAD SCREW NUTS

For Use With PS Series Lead Screws

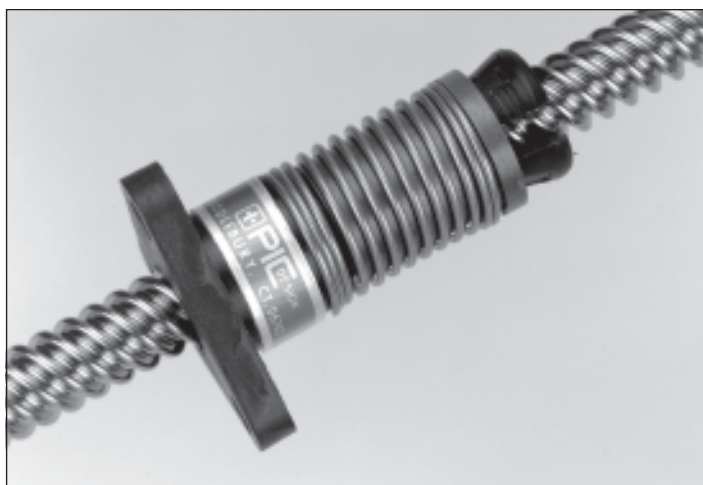

PZ style nuts provide anti-backlash for light loads operating at moderate speeds. These nuts utilize a patented self-lubricating polyacetal radially pre-loaded nut. They are ideally suited for vertical applications requiring noise and vibration control. PZ style nuts are used in conjunction with 1/4" to 1/2" diameter lead screws.

This anti-backlash assembly offers an effective linear actuator for design operations requiring precise positional accuracy and repeatability, with minimum cost.

NUT SPECIFICATIONS

Material: Polyacetal with lubricating additive

Tensile Strength: 9,700 PSI at 73°F

Shear Strength: 9,500 PSI at 73°F

SYSTEM (NUT AND LEAD SCREW) SPECIFICATIONS

Temperature Range: 32°F to 200°F

Coefficient of Friction: .08 Static to .15 Dynamic

Coefficient of Thermal Expansion: 6×10^{-5} in./in./°F

Screw Dia.	Lead (in. or mm)	Drag Torque	Design Load	Part No.		
1/4	0.062	1-4 oz.-in.	5 lbs.	PZ4006N		
	0.250			PZ4025N		
3/8	1.000	2-5 oz.-in.	10 lbs.	PZ4100N		
	1.5 mm			(.007 - .03NM)	(2kg)	PZ4M01.5N
	0.100			2-5 oz.-in.	10 lbs.	PZ6010N
	0.200					PZ6020N
	0.300					PZ6030N
0.500	PZ6050N					
1.000	PZ6100N					
1.200	PZ6120N					
7/16	2 mm	3-6 oz.-in.	15 lbs.	PZ6M02N		
	5 mm			(.014 - .035NM)	(5kg)	PZ6M05N
	0.250			3-6 oz.-in.	15 lbs.	PZ7025N
0.500	PZ7050N					
1/2	3 mm	3-6 oz.-in.	25 lbs.	PZ7M03N		
	5 mm			(.021 - .04NM)	(7kg)	PZ7M05N
	0.050			3-6 oz.-in.	25 lbs.	PZ8005N
0.100	(.021 - .04NM)	(.021 - .04NM)	PZ8010N			
0.200			PZ8020N			
0.500			PZ8050N			
1.000	PZ8100N					

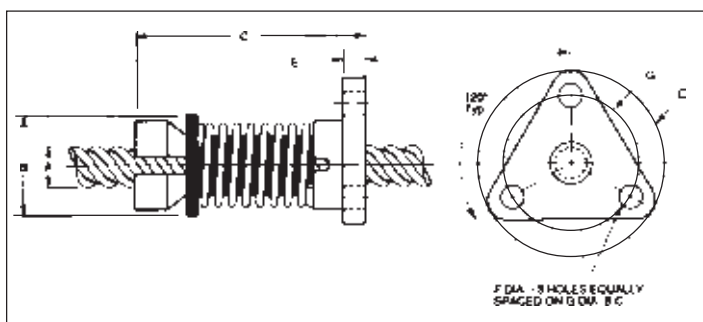

INTEGRALLY MOLDED FLANGE MOUNT

PZ Standard Mounting Dimensions

Series	Screw Dia. A		Nut Dia. B		Nut Length C		Flange Dia. D		Flange Width E		Mounting Holes F		Bolt Circle Dia. G	
	in.	(mm)	in.	(mm)	in.	(mm)	in.	(mm)	in.	(mm)	in.	(mm)	in.	(mm)
PZ4000	1/4	(6.35)	.50	(12.70)	1.0	(25.40)	1.00	(25.40)	.18	(4.57)	.143	(3.63)	.750	(19.05)
PZ6000	3/8	(9.53)	.70	(17.78)	1.9	(48.28)	1.50	(38.10)	.18	(4.57)	.200	(5.08)	1.125	(28.58)
PZ7000	7/16	(11.11)	.800	(20.32)	1.9	(48.26)	1.50	(38.10)	.18	(4.57)	.200	(5.08)	1.125	(28.58)
PZ8000	1/2	(12.70)	.890	(22.61)	2.0	(50.80)	1.62	(41.15)	.26	(6.60)	.200	(5.08)	1.250	(31.75)

Other Mountings Available — Please Contact PIC For Information

PK STYLE LEAD SCREW NUTS

For Use With PS Series Lead Screws



PK style anti-backlash nuts feature a patented split nut with torsional take up to provide increased load capacity and axial stiffness. This design while high in axial stiffness is very low in frictional drag torque (1-3 oz-in). The type of anti-backlash mechanism used in the PK type nut eliminates the need for load compensating preload forces. This series is specifically made for screws of 3/8" diameter, moderate loads and speeds.

NUT SPECIFICATIONS

Material: Polyacetal with lubricating additive
Tensile Strength: 9,700 PSI at 73°F
Shear Strength: 9,500 PSI at 73°F

SYSTEM (NUT AND LEAD SCREW) SPECIFICATIONS

Temperature Range: 32°F to 200°F
Coefficient of Friction: .08 Static to .15 Dynamic
Coefficient of Thermal Expansion: 6×10^{-5} in./in./°F

Screw Dia.	Lead (in. or mm)	Drag Torque	Design Load	Part No.
3/8	0.100	1-3 oz.-in.	20 lbs.	PK6010N
	0.200			PK6020N
	0.300			PK6030N
	0.500			PK6050N
	1.000			PK6100N
	1.200			PK6120N
3/8	2 mm	(.007 - .02NM)	(10kg)	PK6M02N
	5 mm			PK6M05N

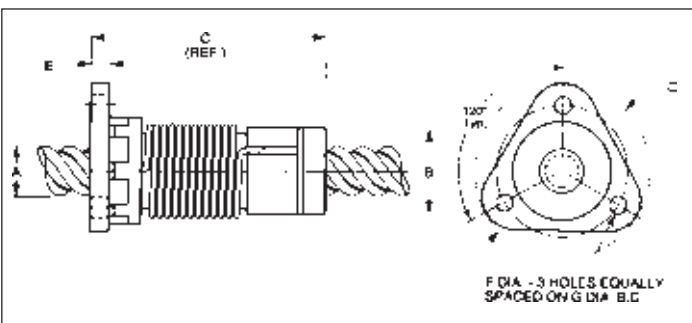

INTEGRALLY MOLDED FLANGE MOUNT

PK Standard Mounting Dimensions

Series	Screw Dia. A	Nut Dia. B	Nut Length C	Flange Dia. D	Flange Width E	Mounting Holes F	Bolt Circle Dia. G
PK6000 (in.)	3/8	.80	2.0	1.5	.19	.20	1.125
PK6000 (mm.)	9.53	20.32	50.80	38.10	4.83	5.08	28.58

PV STYLE LEAD SCREW NUTS

For Use With PS Series Lead Screws

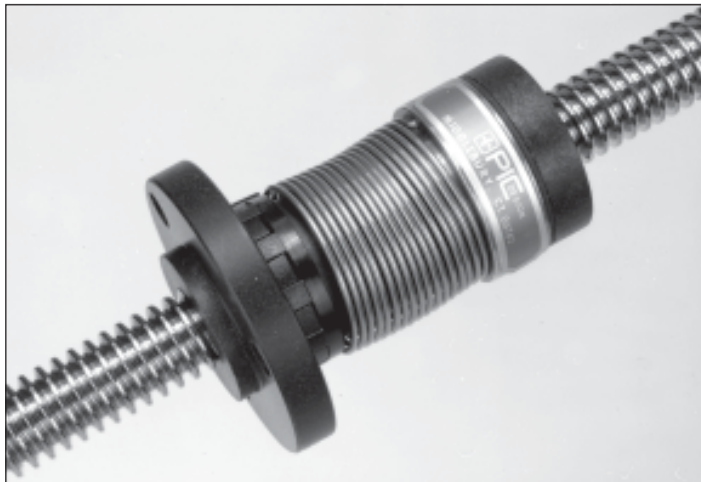

PV style anti-backlash nuts provide a maximum load carrying capability and the lightest axial and radial stiffness of all PIC anti-backlash nuts. They are designed for smooth, quiet operation and long life, made possible by a patented axial take-up mechanism. Because this series is designed to operate with higher loads, operation is only possible with 1/2" and 3/4" diameter lead screws.

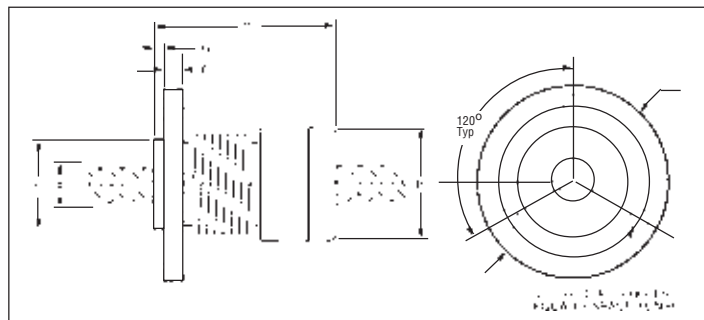

NUT SPECIFICATIONS

Material: Polyacetal with lubricating additive

Tensile Strength: 9,700 PSI at 73°F

Shear Strength: 9,500 PSI at 73°F

SYSTEM (NUT AND LEAD SCREW) SPECIFICATIONS

Temperature Range: 32°F to 200°F

Coefficient of Friction: .08 Static to .15 Dynamic

Coefficient of Thermal Expansion: 6×10^{-5} in./in./°F

Screw Dia.	Lead (in. or mm)	Drag Torque	Design Load	Part No.
1/2	0.050	2-6 oz.-in. (.01 - .04NM)	150 lbs. (68kg)	PV8005N
	0.100			PV8010N
	0.200			PV8020N
	0.500			PV8050N
	1.000			PV8100N
3/4	1.000	3-7 oz.-in. (.02 - .05NM)	350 lbs. (159kg)	PV12100N
	2.000			PV12200N

INTEGRALLY MOLDED FLANGE MOUNT

PV Standard Mounting Dimensions

Series	Screw Dia. A		Nut Dia. B		Nut Length CF		Flange Dia. D		Flange Width E		Pilot Dia. F		Pilot Depth G		Bolt Circle Dia. H	
	in.	(mm)	in.	(mm)	in.	(mm)	in.	(mm)	in.	(mm)	in.	(mm)	in.	(mm)	in.	(mm)
PV8000	1/2	(12.70)	1.12	(28.45)	2.3	(58.42)	1.75	(44.45)	.23	(5.84)	.93	(23.63)	.12	(3.05)	1.406	(35.71)
PV12000	3/4	(19.05)	1.62	(41.15)	2.8	(71.12)	2.38	(60.45)	.31	(7.87)	—	—	—	—	2.00	(50.80)

Please Contact PIC For Optional Mounting Threads Or Special Configuration Requirements.

PRECISION ACME LEAD SCREWS

Inch and Metric

.003 Inch/Foot Lead Accuracy



Material: 303 Stainless Steel

Features:

- Screws are precision rolled.
- Lead accuracy of $\pm .003$ " per foot.
- Straightness tolerance of .010" per foot.
- Class 2G Thread
- Burnished finish of 24 RMS or better due to the rolling process.
- 303 stainless steel used for uniform grain structure to improve lead accuracy and finish.

Available on request & special quotation:

- Teflon "S" coated lead screw assemblies with film thickness of .0005 to .001. Coating improves distribution of lubricant whereby it improves the coefficient of friction between the nut and screw, with reduced torque needed to drive the lead screw assembly. The Teflon coated lead screw assembly increases useful life of the system by more than twofold.

Teflon "S" Coating Properties:

- Coefficient of friction:
 - static = .12
 - dynamic = .10
- Abrasion resistance (TABER) (weight loss in grams, 100 cycles) .04
- Hardness, coating Knoop scale 9-12
- Thickness .0005 to .001 in.

Part Number

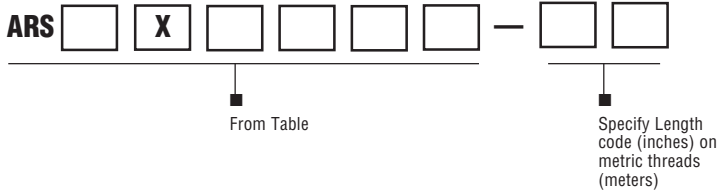

Screw Dia. (in.)	Screw Size	Lead (in.)	Minor Root Dia. (in.)	Efficiency (%)	Weight per ft. (lbs.)	Standard Length (in.)	Part No. Add length to end of Part No.	
3/16	3/16 - 20	0.050	0.119	46	.06	12, 36, 72	ARS1X1820 - <input type="checkbox"/> <input type="checkbox"/>	
1/4	1/4 - 20	0.050	0.190	38	.13		ARS1X2520 - <input type="checkbox"/> <input type="checkbox"/> *	
	1/4 - 16	0.0625	0.170	44	.13		ARS1X2516 - <input type="checkbox"/> <input type="checkbox"/> *	
5/16	5/16 - 8, 4 start (stub)	0.500	0.218	71	.19		ARS4X3108 - <input type="checkbox"/> <input type="checkbox"/>	
3/8	3/8 - 20	0.050	0.315	29	.31		ARS1X3720 - <input type="checkbox"/> <input type="checkbox"/>	
	3/8 - 16	0.0625	0.303	34	.31		ARS1X3716 - <input type="checkbox"/> <input type="checkbox"/> *	
	3/8 - 10	0.100	0.255	46	.27		ARS1X3710 - <input type="checkbox"/> <input type="checkbox"/> *	
	3/8 - 8 (stub)	0.125	0.280	52	.30		ARS1X3708 - <input type="checkbox"/> <input type="checkbox"/>	
	3/8 - 10, 2 start	0.200	0.255	66	.27		ARS2X3710 - <input type="checkbox"/> <input type="checkbox"/>	
	3/8 - 8, 2 start (stub)	0.250	0.280	67	.26		ARS2X3708 - <input type="checkbox"/> <input type="checkbox"/>	
	3/8 - 8, 4 start (stub)	0.500	0.270	77	.28	ARS4X3708 - <input type="checkbox"/> <input type="checkbox"/>		
	3/8 - 5, 5 start	1.000	0.255	79	.27	ARS5X3705 - <input type="checkbox"/> <input type="checkbox"/> **		
3/8 - 4, 5 start (stub)	1.250	0.243	75	.28	ARS5X3704 - <input type="checkbox"/> <input type="checkbox"/> **			
7/16	7/16 - 8, 2 start (stub)	0.250	0.327	64	.40	24, 48, 72	ARS2X4308 - <input type="checkbox"/> <input type="checkbox"/>	
	7/16 - 8, 4 start (stub)	0.500	0.327	75	.42		ARS4X4308 - <input type="checkbox"/> <input type="checkbox"/>	
1/2	1/2 - 10	0.100	0.380	38	.53		ARS1X5010 - <input type="checkbox"/> <input type="checkbox"/> *	
	1/2 - 10, 2 start	0.200	0.380	55	.80		ARS2X5010 - <input type="checkbox"/> <input type="checkbox"/>	
5/8	5/8 - 10	0.100	0.505	32	.85		ARS1X6210 - <input type="checkbox"/> <input type="checkbox"/> *	
	5/8 - 8 (stub)	0.125	0.530	38	.48		ARS1X6208 - <input type="checkbox"/> <input type="checkbox"/>	
	5/8 - 10, 2 start	0.200	0.505	49	.85		ARS2X6210 - <input type="checkbox"/> <input type="checkbox"/>	
Screw Dia. (mm)	Trapezoidal Metric Thread (ISO)	Lead (mm)	Minor Root Dia. (mm)	Efficiency (%)	Weight per meter (kg)		Standard Length (meter)	Part No. Add length to end of Part No.
4	4 x 1 mm	1	2.5	44	.3		.5, 1.0, 1.8	ARS1X041M - <input type="checkbox"/> <input type="checkbox"/>
8	8 x 2 mm	2	5.5	44	.6			ARS1X082M - <input type="checkbox"/> <input type="checkbox"/>
10	10 x 2 mm	2	7.5	38	.7	ARS1X102M - <input type="checkbox"/> <input type="checkbox"/>		
10	10 x 1.5 mm, 4 start	6	7.9	63	.7	ARS4X101M - <input type="checkbox"/> <input type="checkbox"/> ***		
14	14 x 4 mm	4	9.5	47	.9	ARS1X144M - <input type="checkbox"/> <input type="checkbox"/> ***		

NOTE: Screws should not require lubrication. For those instances where lubrication may be desired, a silicone or lithium-based lubricant is suggested.

* Left hand thread available.
 ** 36" max length.
 *** 416 Stainless Steel only.

ACME LEAD SCREW POWER NUTS

Inch and Metric

For use with ACME Lead Screws

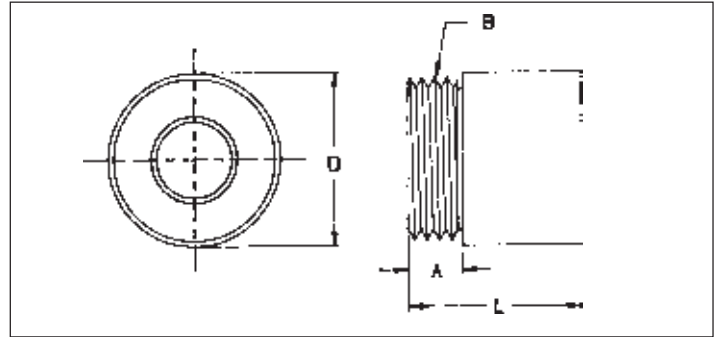

Features:

- Tensile strength (at break) 5900 PSI
- Elongation (at break) 19%
- Flexural yield strength 8000 PSI
- Compressive strength 9500 PSI
- Coefficient of friction:
 - static (40 psi) = .08
 - dynamic (40 psi / 50 fpm) = .12
- Coefficient of linear thermal expansion 5.2×10^{-5} in./in./°F
- Limiting PV (1" dia shaft, 100 FPM) 16000 PSI-FPM

Specifications:

Hardness: Durometer Shore D 75

Temperature Range: Min. 32°F, Max. 180°F

Max. Speed (Unlubricated): 200 SF/M (surface feet per minute)

Material: Turcite X (Acetal - Teflon and Silicon filled)

Note:

It is recommended that dynamic loads not exceed 25% of the static load rating. Factors such as speed, duty cycle, eccentric cantilever loading and temperature can adversely effect load ratings.

- 1) Torque values to raise 1 lb. also apply to anti-backlash nuts for load torque calculations.
- 2) Torque values are for nut & screw only, drag, bearing mounting & drive component inefficiencies need to be considered when determining total necessary torque

For Mounting Flange, See Page 3-13

Major Dia. (in.)	Lead (in.)	Powernut Dimensions (in.)				Flange No.	Max. Static Load	Torque To Raise 1 lb. Load (Oz. - In.)	Part No.
		D	L	A	B				
3/16	0.050	0.62	0.62	3/16	9/16 - 18	FL-3	150 lbs.	0.40	ANR11-1820
1/4	0.050	0.62	0.62	3/16	9/16 - 18	FL-3	200 lbs.	0.40	ANR11-2520
	0.42							ANR11-2516	
5/16	0.500	0.75	0.75	1/4	5/8 - 18	FL-1	250 lbs.	1.8	ANR14-3108
3/8	0.050	0.75	0.75	1/4	5/8 - 18	FL-1	350 lbs.	0.60	ANR11-3720
	0.0625							0.58	ANR11-3716
	0.100							0.64	ANR11-3710
	0.125							0.70	ANR11-3708
	0.200							0.92	ANR12-3710
	0.250							1.1	ANR12-3708
	0.500							1.8	ANR14-3708
	1.000							3.5	ANR15-3705
1.250	4.2	ANR15-3704							
7/16	0.250	1.00	1.00	5/16	15/16 - 16	FL-2	800 lbs.	1.1	ANR12-4308
	0.500							1.9	ANR14-4308
1/2	0.100	1.00	1.00	5/16	15/16 - 16	FL-2	800 lbs.	0.80	ANR11-5010
	0.200							1.1	ANR12-5010
5/8	0.100	1.00	1.00	5/16	15/16 - 16	FL-2	800 lbs.	0.80	ANR11-6210
	0.125							1.0	ANR11-6208
	0.200							1.1	ANR12-6210
Major Dia. (mm.)	Lead (mm.)	Powernut Dimensions (mm)				Flange No.	Max. Static Load	Torque To Raise 1 kg. Load (NM)	Part No.
		D	L	A	B				
4.0	1.0	15	20	5.0	M12 x 1.5	FLM-1	60 kg	.004	ANR11-041m
8.0	2.0	15	20	5.0	M12 x 1.5	FLM-1	100 kg	.009	ANR11-082m
10.0	2.0	25	25	6.4	M20 x 1.5	FLM-2	160 kg	.013	ANR11-102m
10.0	6.0	25	25	6.4	M20 x 1.5	FLM-2	160 kg	.012	ANR14-101m
14.0	4.0	25	25	6.4	M20 x 1.5	FLM-2	350 kg	.015	ANR11-144m

ACME LEAD SCREW ANTI-BACKLASH STYLE NUTS

For use with ACME Lead Screws

Inch and Metric

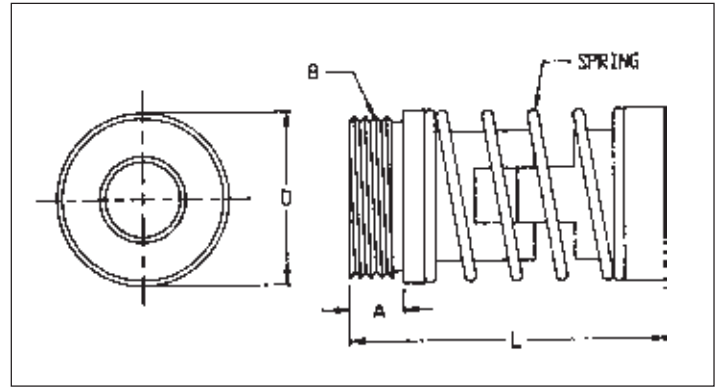
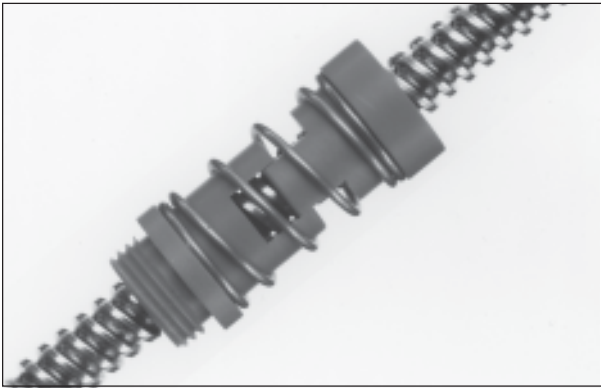

Preload may be increased slightly by adding a SHIM behind the spring, or decreased by repositioning one-half of the nut assembly away from the opposite half. Lubrication is recommended for continuous duty and high speed applications. It is recommended that drive motors be selected with at least 50% additional torque to handle other system inefficiencies.

Specifications:

Temperature Range: Min. 32°F, Max. 180°F

Material: Nut-Turcite X (Acetal - Teflon and Silicone filled)
Spring-300 Series Stainless Steel

For Mounting Flange, See Page 3-13

Major Dia. (in.)	Lead (in.)	AB Nut Dimensions (in.)					Flange No.	Max. Preload (lbs.)	Max Load For Zero Backlash (lbs.)	Torque* (Oz. - in.)	Part No.
		D	L		A	B					
			Max.	Min.							
3/16	0.050	0.62	1.34	1.12	3/16	9/16 - 18	FL-3	5.25	5	6.7	ANR21-1820
1/4	0.050	0.62	1.34	1.12	3/16	9/16 - 18	FL-3	5.25	5	6.7	ANR21-2520
	0.0625									6.1	ANR21-2516
5/16	0.500	0.75	1.7	1.4	1/4	5/8 - 18	FL-1	5.25	5	10.9	ANR24-3108
3/8	0.050	0.75	1.7	1.4	1/4	5/8 - 18	FL-1	5.25	5	11.0	ANR21-3720
	0.0625									8.5	ANR21-3716
	0.100									7.0	ANR21-3710
	0.125									7.0	ANR21-3708
	0.200									7.3	ANR22-3710
	0.250									8.0	ANR22-3708
	0.500									11.2	ANR24-3708
1.000	19.4	ANR25-3705									
1.250	23.1	ANR25-3704									
7/16	0.250	1.00	2.00	1.7	5/16	15/16 - 16	FL-2	11.55	11	18.6	ANR22-4308
	0.500									25.3	ANR24-4308
1/2	0.100	1.00	2.00	1.7	5/16	15/16 - 16	FL-2	11.55	11	19.3	ANR21-5010
	0.200									19.1	ANR22-5010
5/8	0.100	1.00	2.00	1.7	5/16	5/16 - 16	FL-2	11.55	11	22.8	ANR21-6210
	0.125									21.9	ANR21-6208
	0.200									21.8	ANR22-6210
Major Dia. (mm)	Lead (mm)	AB Nut Dimensions (mm)					Flange No.	Max. Preload (Kg)	Max Load For Zero Backlash (Kg)	Torque* (NM)	Part No.
		D	L		A	B					
			Max.	Min.							
4.0	1.0	15	30	25	5.0	M12 x 1.5	FLM-1	2.4	2.3	.093	ANR21-041m
8.0	2.0	15	30	25	5.0	M12 x 1.5	FLM-1	2.4	2.3	.124	ANR21-082m
10.0	2.0	25	50	43	6.4	M20 x 1.5	FLM-2	5.2	5.0	.280	ANR21-102m
10.0	6.0	25	50	43	6.4	M20 x 1.5	FLM-2	5.2	5.0	.275	ANR24-101m
14.0	4.0	25	50	43	6.4	M20 x 1.5	FLM-2	5.2	5.0	.295	ANR21-144m

*Torque figures are based on three factors: load, preload, and efficiency.

ANR STYLE ADJUSTABLE COMPLIANT NUTS

Inch and Metric

For Use With ACME Lead Screws

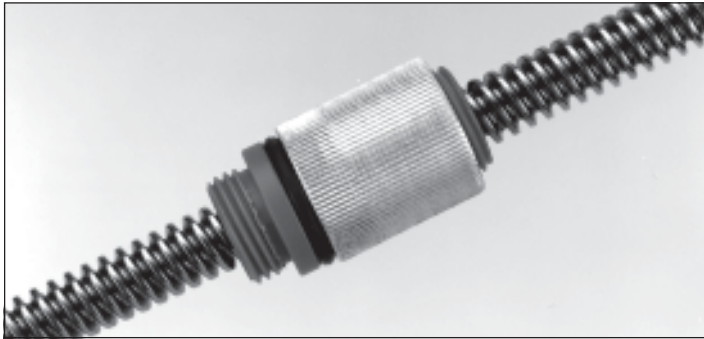

Easily adjusted by turning adjusting nut for desired preload.

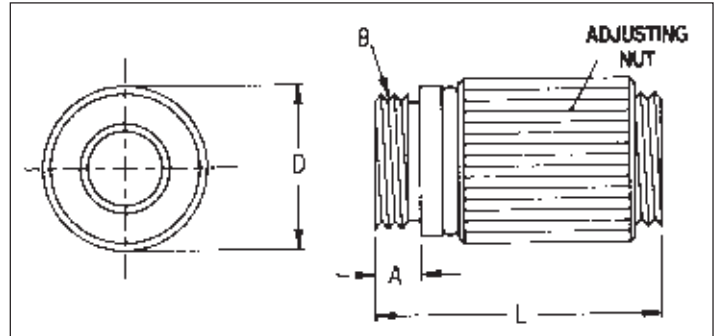

Material:

Nut: Turcite X
 Sleeve: Anodized Aluminum
 "O" Ring: Buna N

Specifications:

Temperature Range: Min. 32°F, Max. 180°F
 Max. Speed (Unlubricated): 200 ft/min
 Material: Turcite X (Acetal - Teflon and Silicon filled)

For Mounting Flange, See Page 3-13

Screw Dia. (in.)	Lead (in.)	Adjustable Nut Dimensions (in.)					Flange No.	Max. Dynamic Load (lbs.)	Torque To Raise 1 lb. Load (oz. - in.)	Part No.
		D	L		A	B				
Max.	Min.									
3/16	0.050	0.62	1.34	1.12	3/16	9/16 - 18	FL-3	35	.40	ANR31-1820
1/4	0.050	0.62	1.34	1.17	3/16	9/16 - 18	FL-3	45	.40	ANR31-2520
	0.0625								.42	ANR31-2516
5/16	0.500	0.75	1.70	1.40	1/4	5/8 - 18	FL-1	60	1.8	ANR34-3108
3/8	0.050	0.75	1.70	1.40	1/4	5/8 - 18	FL-1	85	.60	ANR31-3720
	0.0625								.58	ANR31-3716
	0.100								.64	ANR31-3710
	0.125								.70	ANR31-3708
	0.200								.92	ANR32-3710
	0.250								1.1	ANR32-3708
	0.500								1.8	ANR34-3708
	1.000								3.5	ANR35-3705
1.250	4.2	ANR35-3704								
7/16	0.250	1.00	2.00	1.70	5/16	15/16 - 16	FL-2	130	1.1	ANR32-4308
	0.500								1.9	ANR34-4308
1/2	0.100	1.00	2.00	1.70	5/16	15/16 - 16	FL-2	130	.80	ANR31-5010
	0.200								1.1	ANR32-5010
5/8	0.100	1.00	2.00	1.70	5/16	15/16 - 16	FL-2	130	.80	ANR31-6210
	0.125								1.0	ANR31-6208
	0.200								1.1	ANR32-6210
Screw Dia. (mm)	Lead (mm)	Adjustable Nut Dimensions (mm)					Flange No.	Max. Dynamic Load (Kg)	Torque To Raise 1 kg (NM)	Part No.
		D	L		A	B				
Max.	Min.									
4.0	1.0	15	30	25	5.0	M12 x 1.5	FLM-1	15	.004	ANR31-041m
8.0	2.0	15	30	25	5.0	M12 x 1.5	FLM-1	25	.009	ANR31-082m
10.0	2.0	25	50	43	6.4	M20 x 1.5	FLM-2	40	.013	ANR31-102m
10.0	6.0	25	50	43	6.4	M20 x 1.5	FLM-2	40	.012	ANR34-101m
14.0	4.0	25	50	43	6.4	M20 x 1.5	FLM-2	80	.015	ANR31-144m

STANDARD MOUNTING FLANGES

Inch and Metric

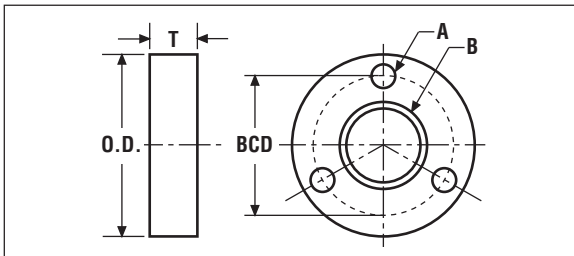

Flange Dimensions					Part Number
O.D.	T	A	BCD	B (thread)	
1.62	1/4	.177	1.25	5/8 - 18	FL-1
2.00	5/16	.266	1.50	15/16 - 16	FL-2
1.25	3/16	.140	1.00	9/16 - 18	FL-3
30	5.0	3.5	22	M12 x 1.5	FLM-1*
40	6.5	3.5	32	M20 x 1.5	FLM-2*

*Sizes in mm.

Material: Aluminum

Finish: Black Anodized

Flanges should be pinned or bonded to the nut to prevent disassembly during operation. Flanges do not have a Set Screw which could deform a nut and possibly cause binding.

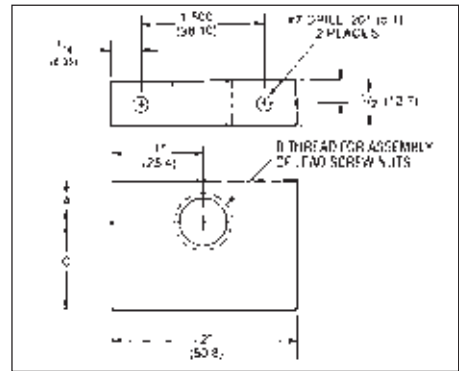

Material: Aluminum Alloy (6061)

Finish: Black Anodized

Inch Sizes			
A ±.002	B Thread	C ±.002	Part No.
.375	5/8 - 18	.625	LMB-1
.562	15/16 - 16	.812	LMB-2
.375	9/16 - 18	.625	LMB-3
Metric Sizes			
9.53	M12 x 1.5	15.88	LMB-1M
14.27	M20 x 1.5	20.62	LMB-2M

FLANGE ADAPTOR

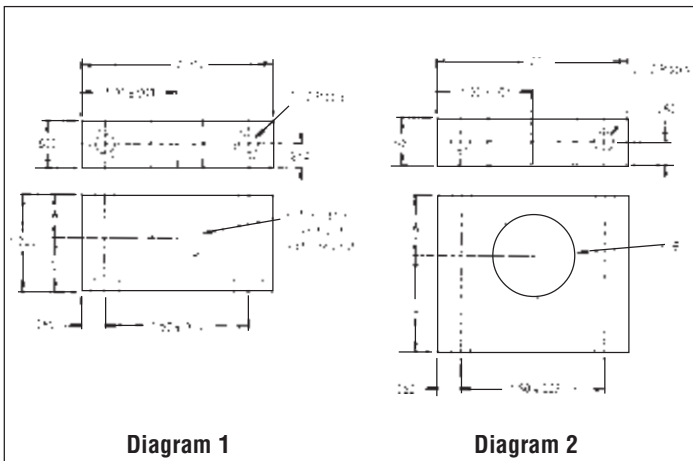

Part No.	Diagram	A	B	C ±.001	D		
					Thru Dia.	C' Bore Dia.	Depth Dia.
LMB-4	1	0.437	9/16 - 18	0.563	0.201	0.312	0.125
LMB-6	2	0.625	5/8 - 18	0.762	0.201	—	—
LMB-8	2	0.625	15/16 - 16	1	0.201	—	—
LMB-10	2	1.062	15/16 - 16	1.625	0.201	—	—

Material: Aluminum Alloy (6061)

Finish: Black Anodized

BEARING HOUSING BLOCKS

Diagram 1

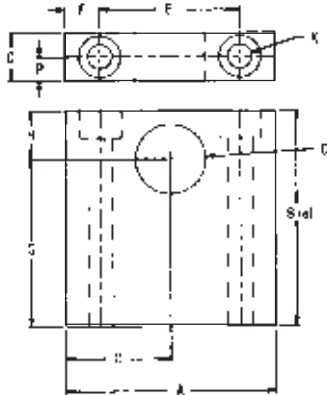

Material: Aluminum
Finish: Black Anodized

Note:
See section 6 for alternate bearing housings

Diagram 2

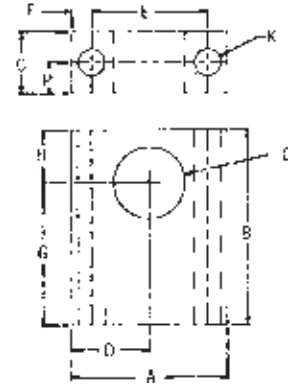

Part No.	Diagram	A	B ref.	C	D ±.001	E ±.001	F	G ±.001	H	K			O +.0002 -.0000	P	Screws
										Thru Dia.	C'Bore Dia.	Depth Dia.			
S12-4	1	0.938	1.000	0.375	0.469	0.625	0.156	0.688	0.312	0.156	0.250	0.141	0.375	0.188	#6
S12-6	2	1.094	1.375	0.438	0.547	0.813	0.140	1.000	0.375	0.188	—	—	0.500	0.219	#8
S12-8	1	1.875	1.938	0.438	0.938	1.250	0.313	1.500	0.438	0.218	0.375	0.250	0.625	0.219	#10
S12-10	1	2.375	2.750	0.625	1.188	1.625	0.375	2.000	0.750	0.339	0.500	0.500	0.875	0.313	5/16

UNIVERSAL BEARING HOUSING BLOCKS

Inch and Metric



Material: Aluminum
Finish: Black Anodized

Note:
See section 6 for alternate bearing housings

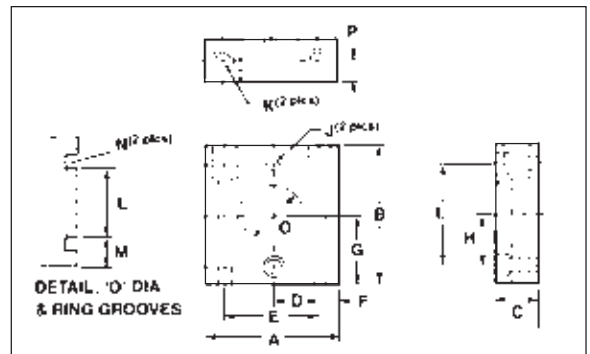

Inch Sizes

Part Number	A	B	C	D ±.003	E ±.003	F	G ±.001	H ±.003	I ±.003	J		K		L*	M	N		O +.0003 -.0000	P	Screws Socket Head			
										Thru Dia.	C'Bore		Thru Dia.			C'Bore				Dia. ±.002	Wide +.003 -.000	J	K
											Dia.	Deep				Dia.	Deep						
S10-06	2	2	.500	.625	1.250	.38	1.000	.625	1.250	.170	.281	.156	.187	.313	.75	.191	.15	.397	.029	.3749	.25	#6	#8
S10-08	2	2	.500	.625	1.250	.38	1.000	.625	1.250	.170	.281	.156	.187	.313	.75	.236	.13	.530	.039	.4999	.25	#6	#8
S10-10	2 1/4	2 1/4	.625	.781	1.562	.34	1.125	.781	1.562	.187	.313	.187	.210	.375	.75	.241	.19	.665	.039	.6249	.31	#8	#10
S10-14	2 1/4	2 1/4	.625	.781	1.562	.34	1.125	.781	1.562	.187	.313	.187	.210	.375	.75	.346	.14	.931	.046	.8749	.31	#8	#10

Metric Sizes

Part Number	A	B	C	D ±.08	E ±.08	F	G ±.03	H ±.08	I ±.08	J		K		L*	M	N		O +.005 -.003	P	Screws Socket Head			
										Thru Dia.	C'Bore		Thru Dia.			C'Bore				Dia. ±.11	Wide (min.)	J	K
											Dia.	Deep				Dia.	Deep						
MS10-10	50.8	50.8	12.7	15.88	31.75	9.6	25.40	15.88	31.75	3.8	6.5	4.0	4.75	8.25	19.0	5.0	3.85	10.4	1.1	10	6.4	M3	M4
MS10-13	50.8	50.8	12.7	15.88	31.75	9.6	25.40	15.88	31.75	3.8	6.5	4.0	4.75	8.25	19.0	6.0	3.35	13.6	1.1	13	6.4	M3	M4
MS10-19	57.2	57.2	15.88	19.84	39.67	8.6	28.53	19.84	39.67	4.75	8.25	4.7	5.80	9.75	19.0	7.5	4.20	20.0	1.1	19	7.9	M4	M5
MS10-22	57.2	57.2	15.88	19.84	39.67	8.6	28.58	19.84	39.67	4.75	8.25	4.7	5.80	9.75	19.0	9.0	3.44	23.0	1.1	22	7.9	M4	M5

* Includes space for outer race preload spacers.

B STYLE PRECISION ROLLED BALL SCREWS & NUTS

Range Of Sizes ■ Up To 0.003 Inch / Foot Lead Accuracy



B Style precision rolled lead screws are available in a choice of stainless steel or alloy steel for higher load capacities.

Typically alloy steel systems can handle operating loads as much as six times greater than stainless steel. Lead screw diameters are available in 3/8, 1/2 or 0.631 inch diameters. Special lengths can be ordered, consult factory. PIC will cut Style B ball screws to your length requirement and supply them with or without machined ends. Annealed ends can also be provided.

HARDNESS SPECIFICATIONS

Stainless Steel: Precipitation hardened 17-4 PH to Rc40 minimum.

Alloy Steel: Induction hardened to Rc56 minimum.

BALL NUTS, FLANGES AND WIPERS

Both single and dual circuit nuts are available. When higher loads are being supported, users should select dual circuit nuts in standard or preloaded versions. Ball nut flanges are available from PIC and must be securely mounted to the nut to prevent the nut from turning off the flange. Wiper kits can be ordered to prevent most foreign material from entering the ball nut as it traverses along the screw.

EFFICIENCY

B Style lead screw systems are 90% efficient. Because of their high efficiency, they will back drive and will require a brake to hold the load.

STRAIGHTNESS

B Style straightness is rated at 0.010 inches per foot TIR and will not exceed 0.025 inches over the entire length of the screw.

TORQUE

The amount of torque required to move the load is measured in inch-pounds. The formulas are as follows:

Rotary to Linear (Drive Torque):

Torque = 0.177 x Load x Lead of Screw

Linear to Rotary (Backdriving Torque):

Torque = 0.143 x Load x Lead of Screw

Preload Torque (Additional Torque Due to Preload Only):

Preload Torque = 0.034 x Preload Setting (lbs.) x Lead of Screw

Torque – H. P.

Torque = $\frac{63,000 \times \text{HP}}{\text{RPM (speed)}}$

Angular Velocity Formula

RPM = $\frac{\text{Velocity (inches/min.)}}{\text{Lead (inches/rev.)}}$

B STYLE PRECISION ROLLED BALL SCREWS & NUTS

3/8" Diameter Screws & Nuts

LEAD — 0.125 Inches

Lead Accuracy (In/ft cumulative)	Standard Length (inches)	Part Number	
		Alloy	Stainless Steel
0.003	12,36,48	BSPRC3708-XX	BSPRS3708-XX
0.007	12,36,48	BSRC3708-XX	BSRS3708-XX

Special lengths to 12 feet. Specify length XX in inches $\pm 1/32$ inch.

BALL NUTS — Use Alloy Ball Nuts with Alloy Lead Screws

SINGLE CIRCUIT BALL NUTS

Contains an average of 62 1/16 inch balls

Material	Operating Load (lbs)	Max. Static Load (lbs)	Part Number
Alloy	150	1300	BNC1-3708
Stainless	25	230	BNS1-3708

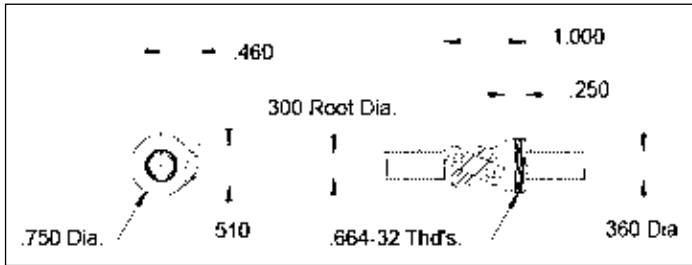

DUAL CIRCUIT BALL NUTS

Contains an average of 124 1/16 inch balls

Material	Operating Load (lbs)	Max. Static Load (lbs)	Part Number
Alloy	300	2600	BNC2-3708
Stainless	50	460	BNS2-3708

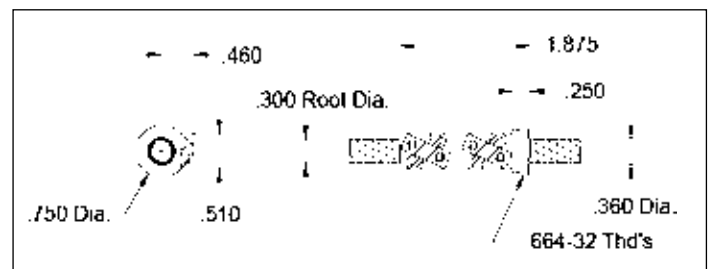

PRELOADED BALL NUTS

Contains an average of 124 1/16 inch balls per unit.
Includes wiper kit and flange.

Material	Recommended Load			Maximum Load			Part Number
	Preload (lbs)	Static (lbs)	Preload (lbs)	Preload (lbs)	Static (lbs)	Preload (lbs)	
Alloy	15	135	1285	45	105	1255	BNC3-3708
Stainless	3	23	228	8	18	223	BNS3-3708

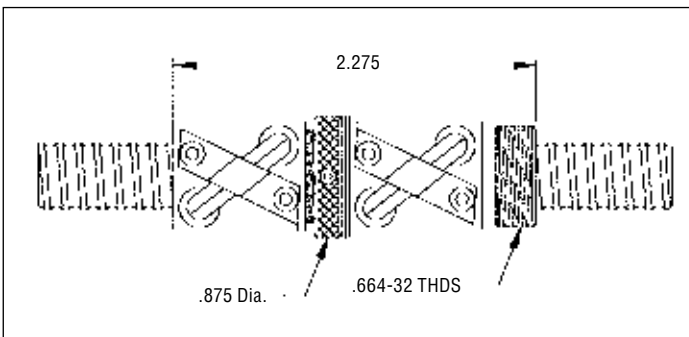

WIPER KIT

Contains 2 brush wipers, user to epoxy on

Diameter (inches)	Thickness (inches)	Part Number	
		Alloy	Stainless Steel
0.750	0.100	BNW-37	BNW-37S

MOUNTING FLANGE

Material	Outside Diameter (inches)	Width (inches)	Bolt Hole Pattern			Part Number
			No. of Holes	Diameter (inches)	Bolt Circle (inches)	
Alloy	1.600	0.270	4	0.177	1.240	BFC-37
Stainless						BFS-37

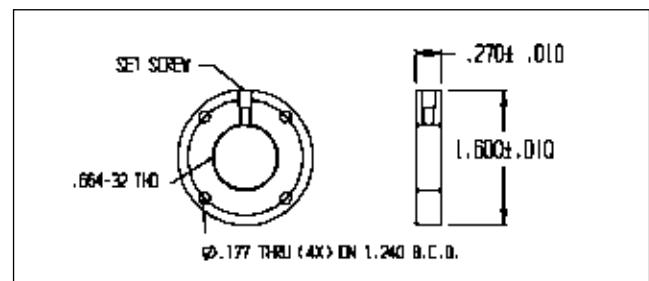

B STYLE PRECISION ROLLED BALL SCREWS & NUTS

3/8" Diameter Screws & Nuts

CRITICAL SPEED

N = CRITICAL SPEED (INCHES PER MINUTE)
 H = LEAD OF SCREW
 D = ROOT DIAMETER OF SCREW
 L = LENGTH BETWEEN SUPPORTS
 C = END FIXITY FACTOR
 $P_s = 0.36$ FIXED FREE
 1.00 SIMPLE - SIMPLE
 1.47 FIXED - SIMPLE
 2.23 FIXED - FIXED

$$N = \left[C \cdot 4.76 \cdot 10^6 \cdot \left(\frac{D \cdot H}{L^2} \right)^2 \cdot 8 \right]$$

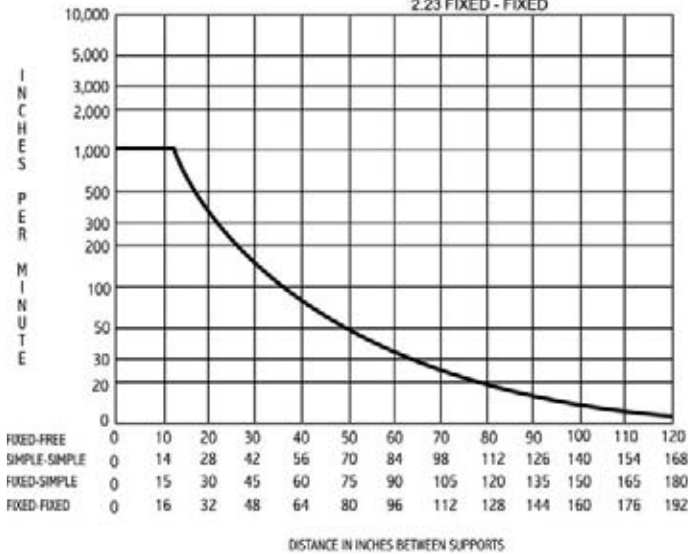

COLUMN LOAD

P = CRITICAL COLUMN LOAD (POUNDS)
 D = ROOT DIAMETER OF SCREW
 L = LENGTH BETWEEN SUPPORTS
 C = END FIXITY FACTOR
 $P_s = 0.25$ FIXED FREE
 1.00 SIMPLE - SIMPLE
 2.00 FIXED - SIMPLE
 4.00 FIXED - FIXED

$$P = \left[C \cdot 14.03 \cdot 10^6 \cdot \left(\frac{D^4}{L^2} \right) \cdot 8 \right]$$

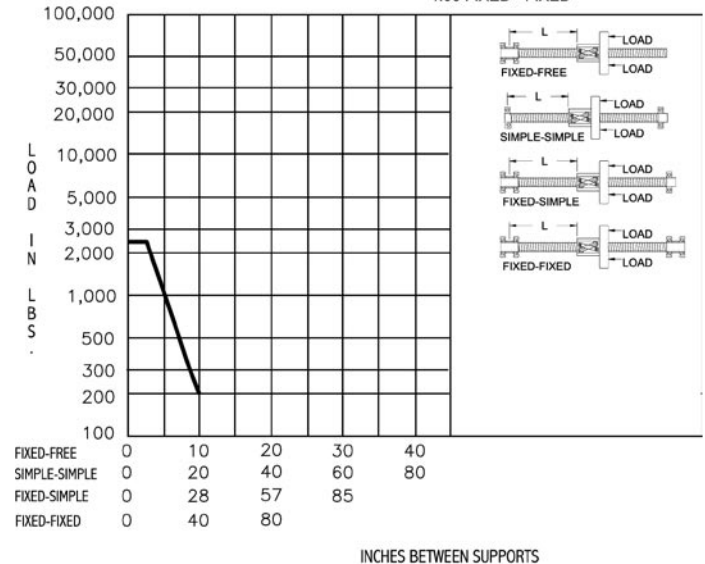

Note: Screws may be ordered with annealed ends for subsequent finishing by the user. Dimensions are always specified by customer. In each case a detailed drawing is necessary.

B STYLE PRECISION ROLLED BALL SCREWS & NUTS

1/2" Diameter Screws & Nuts

LEAD — 0.500 Inches

Lead Accuracy (In/ft cumulative)	Standard Length (inches)	Part Number	
		Alloy Steel	Stainless Steel
0.003	12,36,48	BSPRC5002-XX	BSPRS5002-XX
0.007	12,36,48	BSRC5002-XX	BSRS5002-XX

Special lengths to 12 feet. Specify length xx in inches +/- 1/32 inches.

BALL NUTS

SINGLE CIRCUIT BALL NUTS

Contains an average of 70 1/8 inch balls

Material	Operating Load (lbs)	Max. Static Load (lbs)	Part Number
Alloy	850	4150	BNC2-5002
Stainless	140	750	BNS2-5002

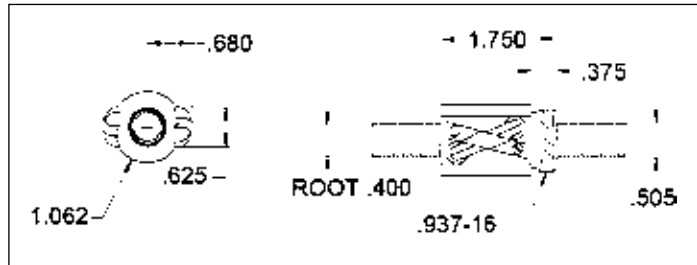

PRELOADED BALL NUTS

Includes wiper kit and flange

Material	Recommended Load			Maximum Load			Part Number
	Preload (lbs)	Rated (lbs)	Static (lbs)	Preload (lbs)	Rated (lbs)	Static (lbs)	
Alloy	85	756	4065	255	595	3895	BNC3-5002
Stainless	14	126	736	42	98	708	BNS3-5002

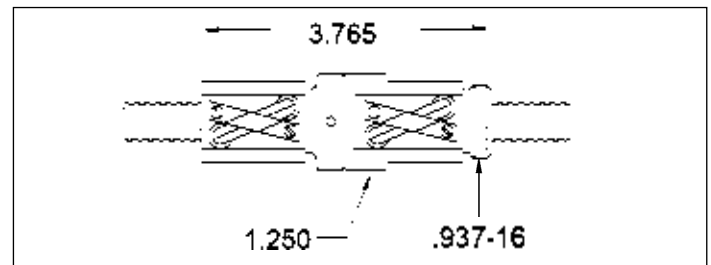

TRUNION STYLE BALL NUTS

Contains an average of 70 1/8 inch balls per dual circuit unit.

Material	Operating Load (lbs)	Max. Static Load (lbs)	Part Number
Alloy	850	4150	BNCT-5002
Stainless	140	750	BNST-5002

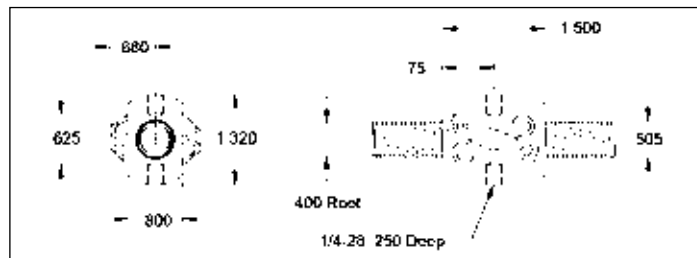

MOUNTING FLANGE

Material	Outside Diameter (inches)	Width (inches)	Bolt Hole Pattern			Part Number
			No. of Holes	Diameter (inches)	Bolt Circle (inches)	
Alloy	2.600	0.530	4	0.266	2.090	BFC-50
Stainless						BFS-50

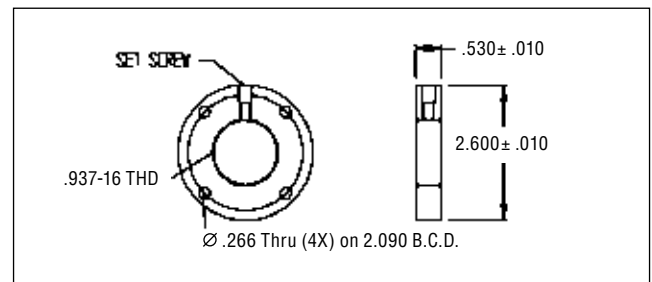

WIPER KIT

Contains 2 brush wipers, user to epoxy on

Diameter (inches)	Thickness (inches)	Part Number	
		Alloy	Stainless Steel
1.062	0.100	BNW-50	BNW-50S

B STYLE PRECISION ROLLED BALL SCREWS & NUTS

1/2" Diameter Screws & Nuts

CRITICAL SPEED

$$N = \left[C \cdot 4.76 \cdot 10^6 \cdot \left(\frac{D \cdot H}{L^2} \right)^{.8} \right]$$

N = CRITICAL SPEED (INCHES PER MINUTE);
 H = LEAD OF SCREW
 D = ROOT DIAMETER OF SCREW
 L = LENGTH BETWEEN SUPPORTS
 C = END FIXITY FACTOR
 $P_S = 0.36$ FIXED-FREE
 1.00 SIMPLE-SIMPLE
 1.47 FIXED-SIMPLE
 2.23 FIXED-FIXED

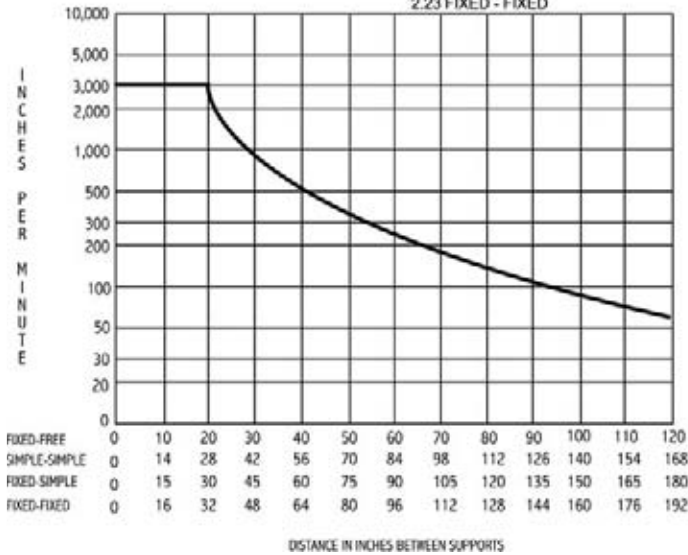

COLUMN LOAD

$$P = \left[C \cdot 14.03 \cdot 10^6 \cdot \left(\frac{D^4}{L^2} \right)^{.8} \right]$$

P = CRITICAL COLUMN LOAD (POUNDS)
 D = ROOT DIAMETER OF SCREW
 L = LENGTH BETWEEN SUPPORTS
 C = END FIXITY FACTOR
 $P_S = 0.25$ FIXED-FREE
 1.00 SIMPLE-SIMPLE
 2.00 FIXED-SIMPLE
 4.00 FIXED-FIXED

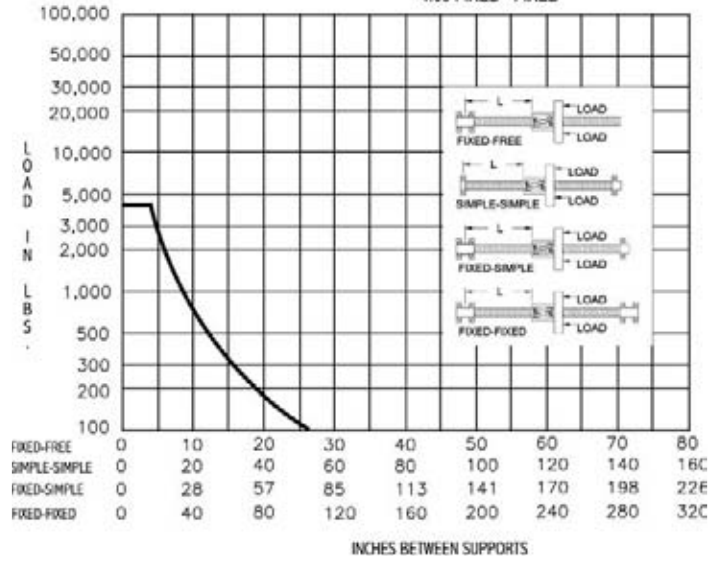

Note: Screws may be ordered with annealed ends for subsequent finishing by the user. Dimensions are always specified by customer. In each case a detailed drawing is necessary.

B STYLE PRECISION ROLLED BALL SCREWS & NUTS

0.631" Diameter Economy Screws & Nuts

LEAD — 0.200 Inches

Lead Accuracy (In/ft cumulative)	Standard Length (inches)	Part Number	
		Alloy Steel	Stainless Steel
0.003	36, 48, 72	BSPRC6305-XX	BSPRS6305-XX
0.007	36, 48, 72	BSRC6305-XX	BSRS6305-XX

Special lengths to 12 feet. Specify length xx in inches +/- 1/32 inches.

BALL NUTS

SINGLE CIRCUIT NUTS

Contains an average of 67 1/8 inch diameter balls per unit.

Material	Operating Load (lbs)	Max. Static Load (lbs)	Part Number
Alloy	825	6250	BNC1-6305
Stainless	170	1250	BNS1-6305

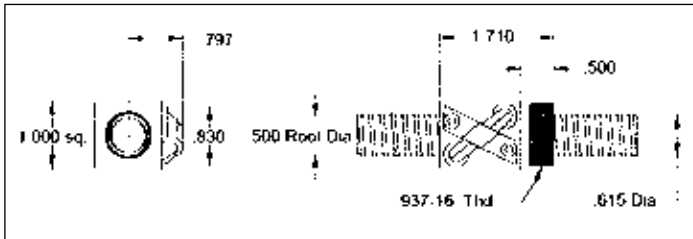

DUAL CIRCUIT BALL NUTS

Contains an average of 134 1/8 inch diameter balls per unit.

Material	Operating Load (lbs)	Max. Static Load (lbs)	Part Number
Alloy	1650	9000	BNC2-6305

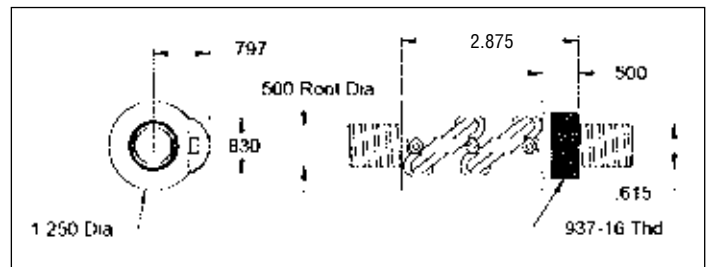

PRELOADED BALL NUTS

Includes wiper kit and flange.

Material	Recommended Load			Maximum Load			Part Number
	Preload (lbs)	Rated (lbs)	Static (lbs)	Preload (lbs)	Rated (lbs)	Static (lbs)	
Alloy	83	742	6067	249	576	5901	BNC3-6305
Stainless	17	153	1233	51	119	1199	BNS3-6305

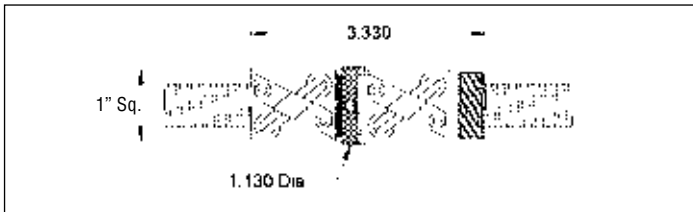

MOUNTING FLANGE

Material	Outside Diameter (inches)	Width (inches)	Bolt Hole Pattern			Part Number
			No. of Holes	Diameter (inches)	Bolt Circle (inches)	
Alloy	2.600	0.530	4	0.266	2.090	BFC-63
Stainless						BFS-63

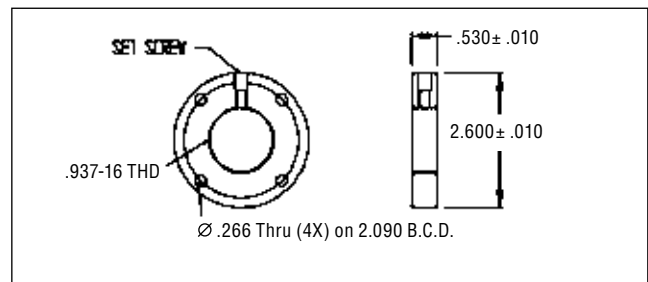

WIPER KIT

Contains 2 brush wipers and 1 end cap.

Diameter (inches)	Thickness (inches)	Part Number	
		Alloy	Stainless Steel
0.975	0.100	BNW-63	BNW-63S

B STYLE PRECISION ROLLED BALL SCREWS & NUTS

0.631" Diameter Screws & Nuts

CRITICAL SPEED

$$N = \left[C \cdot 4.76 \cdot 10^6 \cdot \left(\frac{D \cdot H}{L^2} \right)^{-8} \right]$$

N = CRITICAL SPEED (INCHES PER MINUTE);
 H = LEAD OF SCREW
 D = ROOT DIAMETER OF SCREW
 L = LENGTH BETWEEN SUPPORTS
 C = END FIXITY FACTOR
 $P_S = 0.36$ FIXED-FREE
 1.00 SIMPLE-SIMPLE
 1.47 FIXED-SIMPLE
 2.23 FIXED-FIXED

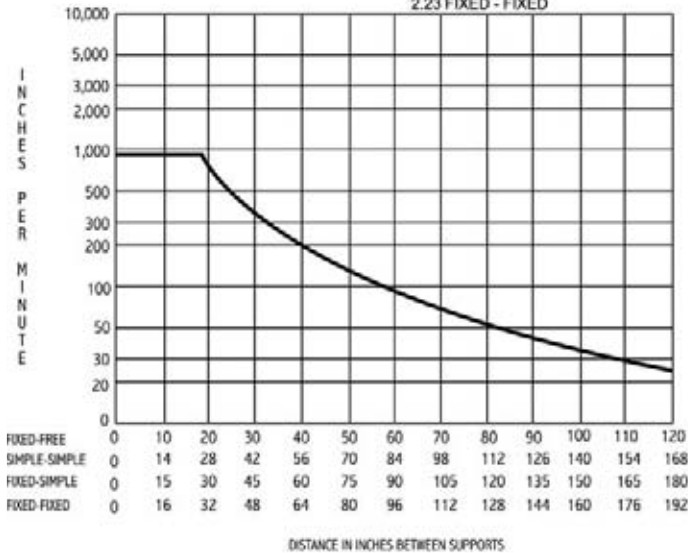

COLUMN LOAD

$$P = \left[C \cdot 14.03 \cdot 10^6 \cdot \left(\frac{D^4}{L^2} \right)^{-8} \right]$$

P = CRITICAL COLUMN LOAD (POUNDS)
 D = ROOT DIAMETER OF SCREW
 L = LENGTH BETWEEN SUPPORTS
 C = END FIXITY FACTOR
 $P_S = 0.25$ FIXED-FREE
 1.00 SIMPLE-SIMPLE
 2.00 FIXED-SIMPLE
 4.00 FIXED-FIXED

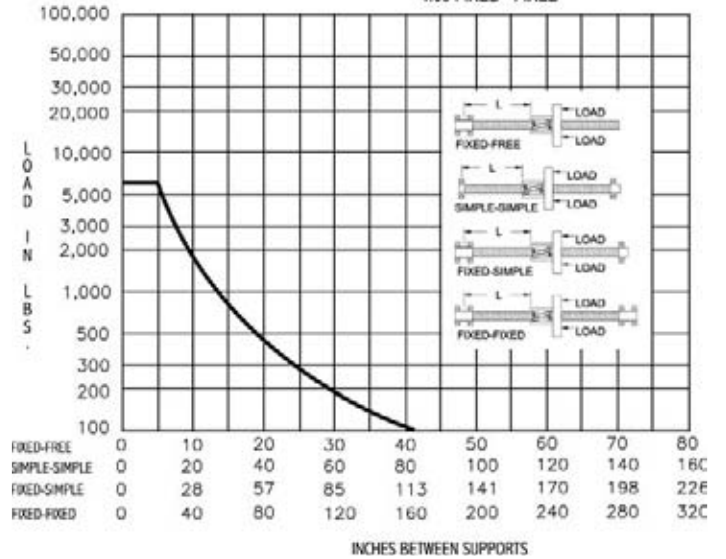

Note: Screws may be ordered with annealed ends for subsequent finishing by the user. Dimensions are always specified by customer. In each case a detailed drawing is necessary.

B STYLE PRECISION ROLLED BALL SCREWS & NUTS

Technical Information

LEAD: The linear distance the ball nut or screw will travel in one revolution.

LEAD ACCURACY: The maximum variation of lead measured in inches per foot. The standard grade of accuracy is .007" per foot cumulative. The premium grade is .003" per foot cumulative.

BACKLASH (AXIAL LASH): The axial-free movement between the ball nut and ball screw. It determines the amount of lost motion between the ball nut and screw on a horizontal application. Backlash on standard nuts range from .004 to .018 inches, depending on size of screw.

PRELOAD: The use of two groups of ball bearings, loaded in opposite directions, to eliminate backlash in a ball screw assembly. Preloading increases screw stiffness and provides for accurate positioning with very little increase in applied torque.

EFFICIENCY: The ratio of work output divided by work input. Generally this is greater than 90 percent.

THRUST LOAD: A load parallel to and concentric with the center line of the ball screw, which acts continuously in the same direction. Thrust loading is the recommended method of attaching the load to the ball screw.

COMPRESSION (COLUMN) LOAD: A load that tends to buckle or compress the screw shaft.

TENSION LOAD: A load that tends to stretch the screw shaft. A greater selection of screw sizes are available when tension loading is present because there are no column load limitations.

OFF-CENTER LOAD: A load that tends to "cock" the ball nut on the screw. This type of loading will reduce ball screw life.

SIDE LOAD: A load that is applied perpendicular to the screw shaft. This type will also reduce the life of a ball screw assembly.

Dynamic Load (Operating) Rating: The maximum thrust load under which a ball screw assembly will achieve a minimum of 1,000,000 inches of travel life.

STATIC LOAD: The maximum load (including shock loads) that can be applied to a stationary ball screw assembly before there is permanent deformation of the ball track in the ball nut or screw.

BALL SCREW LIFE (Life Expectancy): Is expressed as total revolutions or inches of travel an assembly will operate under a rated load in a clean environment with proper lubrication. About 90 percent of all ball screws operated at rated loads will meet or exceed a million inches of life before evidence of fatigue appears. Although 10 percent may not reach a million inches, 50 percent could exceed 5 million inches.

TEMPERATURE: Ball screws operate with normal efficiency between temperatures of -65° F to 300° F, with suitable lubricants.

LUBRICATION: Ball screws should not be operated without proper lubrication. A spindle or 10-weight oil is recommended. For applications with infrequent cycles, a light lithium grease is recommended.

FINISH ON BALL SCREW ASSEMBLY: Ball screw assemblies are supplied with Black Oxide-type finish.

BRUSH WIPERS: Brush wipers help to prohibit contaminants from entering the ball screw assembly. Brush wipers are recommended for any application where contaminants might be deposited on the ball screw.

LINEAR MOTION SYSTEM COMPONENTS

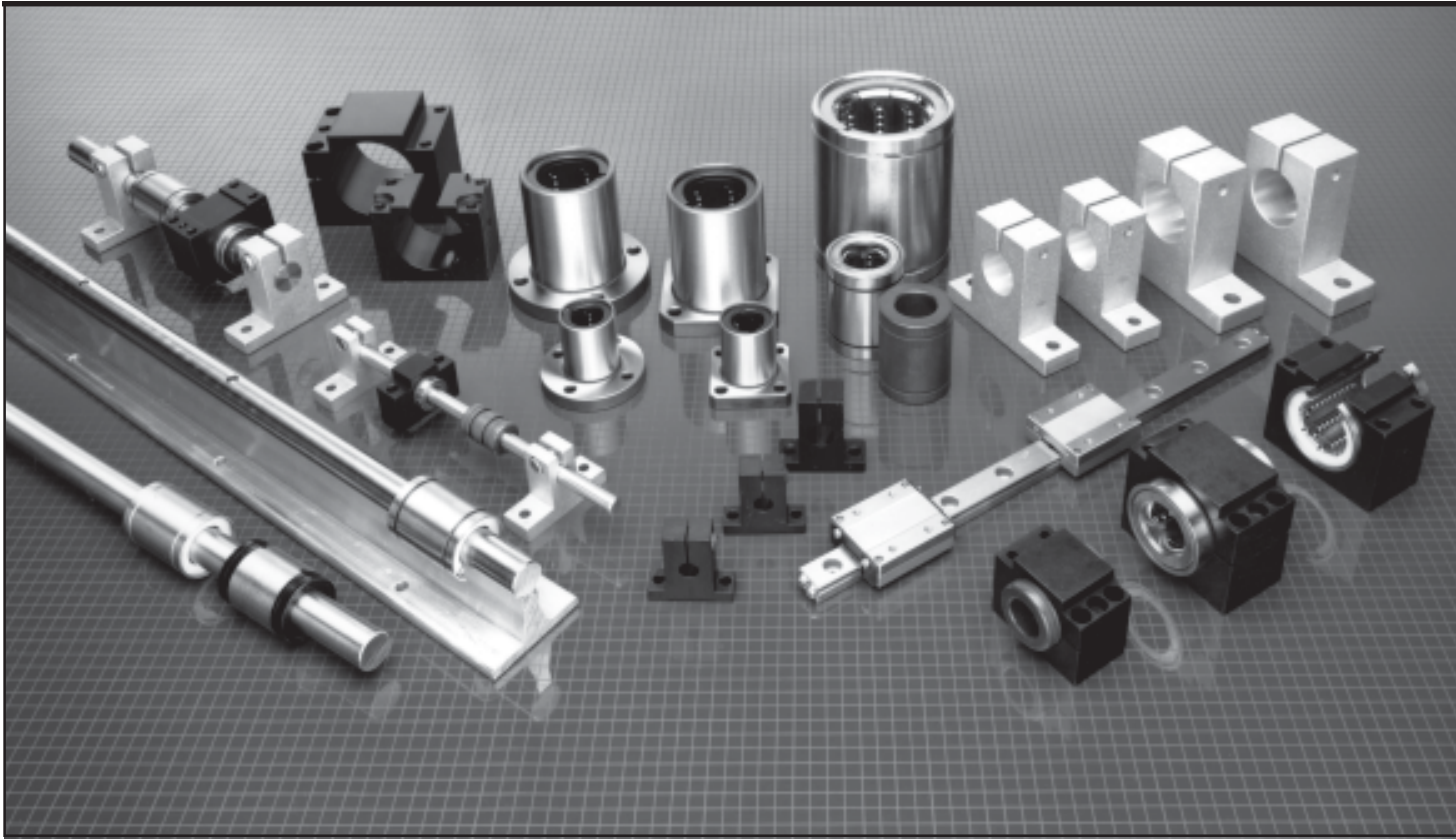

LINEAR MOTION SYSTEM COMPONENTS

PIC Design has added a most comprehensive selection of precision components for linear motion applications. Our standard components range in shaft and bearing sizes from 1/4 in. to 1-1/2 in. diameter and linear guides with travel from 4 in. to 35 in.

All components are available in inch and metric sizes.

PIC Linear Motion Products — A Brief Overview

PRECISION SHAFTING

Precision case hardened and ground shafting include C-1060 steel case hardened to Rockwell 60-65C, 440C stainless steel case hardened to Rockwell 50-55C as well as precision ground 303 stainless steel (Rockwell 70-95B typical).

PRE-DRILLED SHAFTING

Shafting is available with pre-drilled and tapped mounting holes matching our pre-drilled shaft support rails.

SUPPORT RAILS

Aluminum support rails for intermittent or continuous support can be supplied with or without mounting holes.

SHAFT SUPPORT HANGERS

Cast aluminum shaft hangers to accommodate PIC shaft sizes.

LINEAR BEARINGS — RECIRCULATING BALL

High precision linear bearings enable endless rectilinear motion with contained rolling recirculating balls. Available in closed, adjustable or open styles.

LINEAR SELF-LUBE NON METALLIC BEARINGS

Engineered plastic, self-lubricating bearings, interchangeable with all makes of linear ball bearings. Use them for linear or rotational motion with hardened shafting or with lower cost, non-corrosive “soft” 300 series stainless steel ground shafting. Available in closed, adjustable and open style.

CERAMIC COATED LINEAR BEARINGS

Ceramic coated hard aluminum alloy with rotary/linear motion capability and low friction. Allows speeds up to 400 SFM, loads up to 5000 PSI with PV factor of 40,000.

LINEAR BEARING BRACKETS (PILLOW BLOCKS), CARRIAGE TOPS AND PRE-ASSEMBLED SUB-SYSTEMS

Offered to assist customers in selecting the most appropriate linear motion components and sub-systems.

SPECIALS

Custom sub systems available to customer specifications using PIC linear motion components.

TECHNICAL SECTION

Whatever your application, PIC Design offers a linear motion component that will work for you. Determine all loads, magnitude and direction, force and torque for your system requirements. Use of this data should enable users to select individual components, then select and specify all parts from this comprehensive offering.

END SUPPORTS VS. RAIL SUPPORT

Knowing the load to be carried by the linear motion system will help determine the proper diameter of the shafts.

By using the shaft deflection table below, you can estimate the amount each shaft will deflect at the center of the stroke under maximum load. If deflection must be minimized, a continuous or intermittent support rail should be used.

BEARING SPEEDS

Linear bearing systems using recirculating ball bearings can travel at about 250 ft./min.; ceramic coated bearings at about 400 ft./min.; and our PIC self-lubricating linear bearing at 200 ft./min.

SHAFT HARDNESS

Rockwell 55 to 60C is required for "no grooving" of the shaft when using recirculating ball bearings or ceramic coated bearings. Use our PIC C1060 hardened and ground steel shaft; or where application dictates, 440 C stainless steel hardened and ground shaft. PIC self-lube linear bearings can be used with above shafting as well as the more economical and corrosion resistant "soft" 303 stainless steel (Rockwell 70-95B).

LINEAR MOTION GUIDES (See Section 2 — Linear Slides)

These guides offer excellent positioning accuracy, low friction, high load bearing capabilities and greater compactness with recirculating ball or crossed roller slide design.

LUBRICATION

In applications where operating speeds are low and loads are light, linear recirculating ball bearings can be used without lubrication. However, to protect the highly polished bearing surfaces from corrosion and wear, a lubricant is recommended for most applications.

Use light oil for good surface adhesion and greater bearing protection.

Shaft Deflection Table For Use In Design And Application Of Linear Motion Devices

Shaft Diameter	Deflection Per Pound at Center of Shaft Supported at Ends (Not Fixed)												
	Length of Unsupported Section (inches)												
	4	6	8	10	12	16	20	24	30	36	42	48	72
1/4"	2.34x10 ⁻⁴	7.90x10 ⁻⁴	1.87x10 ⁻³	3.66x10 ⁻³	6.33x10 ⁻³	1.50x10 ⁻²	2.93x10 ⁻²	5.06x10 ⁻²	1.00x10 ⁻¹				
3/8"	4.81x10 ⁻⁵	1.62x10 ⁻⁴	3.85x10 ⁻⁴	7.15x10 ⁻⁴	1.30x10 ⁻³	3.07x10 ⁻³	5.72x10 ⁻³	1.04x10 ⁻²	1.93x10 ⁻²	3.33x10 ⁻²	5.29x10 ⁻²	7.90x10 ⁻²	
1/2"	1.45x10 ⁻⁵	4.90x10 ⁻⁵	1.15x10 ⁻⁴	2.27x10 ⁻⁴	3.93x10 ⁻⁴	9.30x10 ⁻⁴	1.60x10 ⁻³	3.14x10 ⁻³	6.13x10 ⁻³	1.26x10 ⁻²	1.68x10 ⁻²	2.51x10 ⁻²	8.47x10 ⁻²
3/4"	2.86x10 ⁻⁶	9.68x10 ⁻⁶	2.29x10 ⁻⁵	4.48x10 ⁻⁵	7.74x10 ⁻⁵	1.83x10 ⁻⁴	3.68x10 ⁻⁴	6.20x10 ⁻⁴	1.21x10 ⁻³	2.08x10 ⁻³	3.32x10 ⁻³	4.95x10 ⁻³	1.67x10 ⁻²
1"	9.01x10 ⁻⁷	3.08x10 ⁻⁶	7.03x10 ⁻⁶	1.42x10 ⁻⁵	2.46x10 ⁻⁵	5.84x10 ⁻⁵	1.14x10 ⁻⁴	1.97x10 ⁻⁴	3.85x10 ⁻⁴	6.64x10 ⁻⁴	1.05x10 ⁻³	1.57x10 ⁻³	5.30x10 ⁻³
1 1/4"	3.72x10 ⁻⁷	1.25x10 ⁻⁶	2.98x10 ⁻⁶	5.81x10 ⁻⁶	1.00x10 ⁻⁵	2.38x10 ⁻⁵	4.65x10 ⁻⁵	8.05x10 ⁻⁵	1.57x10 ⁻⁴	2.71x10 ⁻⁴	4.30x10 ⁻⁴	6.42x10 ⁻⁴	2.17x10 ⁻³
1 1/2"	1.79x10 ⁻⁷	6.05x10 ⁻⁷	1.43x10 ⁻⁶	2.80x10 ⁻⁶	4.84x10 ⁻⁶	1.15x10 ⁻⁵	2.24x10 ⁻⁵	3.87x10 ⁻⁵	7.56x10 ⁻⁵	1.31x10 ⁻⁴	2.07x10 ⁻⁴	3.10x10 ⁻⁴	1.03x10 ⁻³
2"	5.66x10 ⁻⁸	1.91x10 ⁻⁷	4.53x10 ⁻⁷	8.95x10 ⁻⁷	1.53x10 ⁻⁶	3.62x10 ⁻⁶	7.08x10 ⁻⁶	1.22x10 ⁻⁵	2.39x10 ⁻⁵	4.13x10 ⁻⁵	6.55x10 ⁻⁵	9.78x10 ⁻⁵	3.30x10 ⁻⁴

Basic Dynamic Load Rating (C)

This term means such load that, when a certain number of identical linear systems are individually run in the same conditions, 90% of them can run with the load (with a constant value in a constant direction) for a distance of 50 x 10³ meters without damage caused by rolling fatigue.

Static Safety Factor (fs)

This factor is used to derate the basic static load (Co) for the sake of safety, depending on the conditions of use as shown in Table 1.

Table 1. Static Safety Factors

Condition of use	Low limit of fs
When in regular operating condition	1~2
When especially smooth running performance is needed	2~4
When the equipment is subject to vibration and shock	3~5

Basic Static Load Rating (Co)

This term defines a static load such that, at the contacting position where the maximum stress is exercised, the sum of the permanent deformation of the rolling body and that of the rolling plane is 0.0001 time of the diameter of the rolling body.

Rating Life (L)

Rating life is the total travelling distance that 90% of a group of linear systems of the same size can reach without causing any flaking when they operate under the same conditions.

The rating life can be obtained from the following equation with the basic dynamic load rating and the load on the linear system:

$$\text{For ball type: } L = \left(\frac{C}{P} \right)^3 \cdot 50$$

$$\text{For roller type: } L = \left(\frac{C}{P} \right)^{10/3} \cdot 50$$

L: Rating life (km) C: Basic Dynamic load rating (kgf)
P: Load (kgf)

PRECISION CASE HARDENED & GROUND SHAFTING

Inch and Metric

For Linear Motion Applications

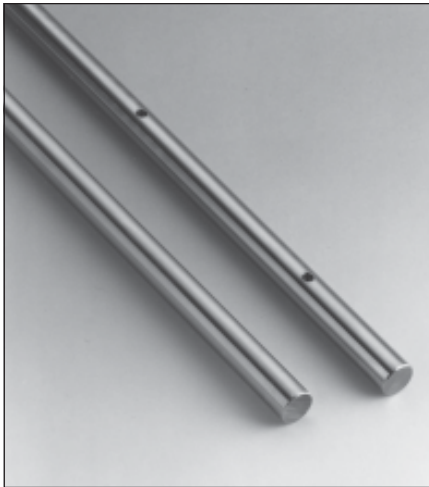

Materials and Hardness:

C-1060 steel, case hardened to Rockwell 60-65C

440 C stainless steel, case hardened to Rockwell 50-55C

303 stainless steel, (for use with engineered plastic bearings), has approximate hardness of Rockwell 75-95B.

C-1060 can be supplied with hard satin chrome finish at additional cost. Special orders only. (Adds .0001 to .0002 to diameter).

Finish: Normally between 10 and 16 micro-inches RMS. Other finishes can be furnished to meet special requirements.

Length Tolerances: Shafting is stocked in 6 to 10 foot lengths, and is supplied to required lengths $\pm 1/16"$ ($\pm 1.5\text{mm}$). If required, closer length tolerances can be supplied at additional cost.

Straightness: With the exception of 1/4" and 3/8" diameters, the standard straightness tolerance is .001"-.002" per foot cumulative. Straighter lengths to meet more stringent requirements can be supplied at additional cost.

Chamfered Ends: Normally, all shafts are rough cut. Precision chamfers or other dimensions are classified as a special fabrication and carry extra charges.

Maximum Lengths: The maximum lengths in stock for each diameter are shown in the tables.

HOW TO ORDER

When ordering shafts that do not require any special machining, simply add length (in inches or mm) requirement to Part Number. Example: A10-8-20".

Inch Shaft Diameters

Nominal Diameter (Inches)	Size & Tol. (Inches)	Max Length (ft)	C-1060 Steel Hardened & Ground		440 C stainless Hardened & Ground		303 Stainless Steel Ground Part No.
			Case Depth	Part No.	Case Depth	Part No.	
1/4	.2485/.2490 .2490/.2495	6	.040	A10-4 A10L-4	—	—	A11-4 —
3/8	.3735/.3740 .3740/.3745	6	.040	A10-6 A10L-6	—	—	A11-6 —
1/2	.4985/.4990 .4990/.4995	6	.060	A10-8 A10L-8	.060	A12-8 —	A11-8 —
5/8	.6235/.6240 .6240/.6245	10	.060	A10-10 A10L-10	.060	A12-10 —	A11-10 —
3/4	.7485/.7490 .7490/.7495	10	.060	A10-12 A10L-12	.060	A12-12 —	A11-12 —
1	.9985/.9990 .9990/.9995	10	.080	A10-16 A10L-16	.080	A12-16 —	A11-16 —
1 1/4	1.2485/1.2490 1.2490/1.2495	10	.080	A10-20 A10L-20	.080	A12-20 —	A11-20 —
1 1/2	1.4984/1.4989 1.4989/1.4994	10	.080	A10-24 A10L-24	.080	A12-24 —	A11-24 —

Note: L Series shafting should be used with self-aligning linear bearings.

Metric Shaft Diameters

Nominal Diameter (mm)	Tolerance μm	Max. Length (mm)	C-1060 Steel Hardened & Ground		440C Stainless Steel Hardened & Ground		303 Stainless Steel Ground Part No.
			Case Depth	Part No.	Case Depth	Part No.	
5	0/-10	700	1.0	MA10-05	1.0	MA12-05	MA11-05
8	0/-10	1500	1.0	MA10-08	1.0	MA12-08	MA11-08
12	0/-10	3000	1.0	MA10-12	1.0	MA12-12	MA11-12
16	0/-10	3000	1.5	MA10-16	1.5	MA12-16	MA11-16
20	0/-12	3000	1.5	MA10-20	1.5	MA12-20	MA11-20
25	0/-12	3000	1.5	MA10-25	1.5	MA12-25	MA11-25
30	0/-12	3000	2.0	MA10-30	2.0	MA12-30	MA11-30
40	0/-15	3000	2.0	MA10-40	2.0	MA12-40	MA11-40

SPECIAL PRECISION MACHINING

Quotations are provided after receipt of a faxed drawing, rough sketch or verbal description. Indicate quantity required.

Metric Conversion To Inches: .03937 x metric dimension

Inch Conversion To Metric: 25.4 x inch dimension

PRE-DRILLED SHAFTS

TYPE D Solid AISI C-1060, 440C & 303 Stainless Steel Shafts With Pre-drilled & Tapped Mounting Holes

Inch and Metric

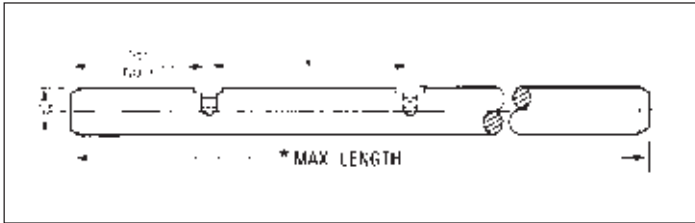

Example: A10-8D24 = C1060 shaft, 1/2 diameter predrilled, 24" long.

PRE-DRILLED SHAFTS

INCH SHAFT DIAMETERS					
Nominal Diameter (inch)	Diameter Tolerance	"X" Space ±.015 (inch)	Tap Size	C1060 Steel Hardened & Ground Part No.	440C S.S. Hardened & Ground Part No.
1/2	.4990/.4995	4	6-32	A10-8D	A12-8D
5/8	.6240/.6245	4	8-32	A10-10D	A12-10D
3/4	.7490/.7495	6	10-32	A10-12D	A12-12D
1	.9990/.9995	6	1/4-20	A10-16D	A12-16D
1 1/4	1.2490/1.2495	6	5/16-18	A10-20D	A12-20D
1 1/2	1.4989/1.4994	8	3/8-16	A10-24D	A12-24D

METRIC SHAFT DIAMETERS					
Nominal Diameter (mm)	Diameter Tolerance (µm)	"X" Space ±.38 (mm)	Tap Size	C1060 Steel Hardened & Ground Part No.	
12	0/-10	120	M4 x .7	MA10-12D	
16	0/-10	150	M5 x .8	MA10-16D	
20	0/-12	150	M6 x 1.0	MA10-20D	
25	0/-12	200	M8 x 1.25	MA10-25D	
30	0/-12	200	M10 x 1.5	MA10-30D	
40	0/-15	200	M10 x 1.5	MA10-40D	

* Maximum length available is 6 feet (1830 mm).
For longer lengths, please contact factory

Note: Standard first hole dimension on in-stock shafts is 1/2 of "X" dimension but different first-hole locations may be specified when ordering, providing its location is not more than the "X" hole spacing.

ALUMINUM SHAFT SUPPORT RAILS

Type PSR Extruded Aluminum Shaft Support Rails (Solid Rail — No Holes)

Inch And Metric

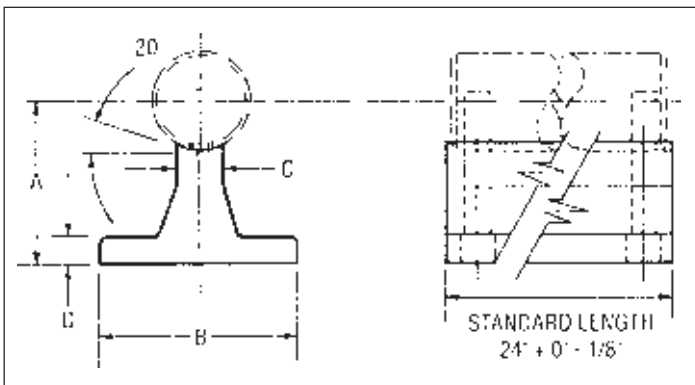

These rails are supplied without mounting holes and can be used horizontally or vertically to provide optimum rigidity (see pre-drilled aluminum rails for sizes and specifications). Shaft support rails are available in standard lengths of 24" + 0", -1/8 (600 + 0, -3.2 mm), but can be supplied to meet shorter length requirements or placed end to end to meet longer length requirements.

Note: To accommodate in-between shaft sizes, use the shaft support rail size that comes closest to the diameter of your shaft. If shaft diameter falls in between, use the next larger rail.

Inch Sizes						Metric Sizes					
Nom. Shaft Dia. (in)	A ± .002	B	C	D	Part No.	Nom. Shaft Dia. (mm)	A ± .08	B (mm)	C (mm)	D (mm)	Part No.
1/2	1.125	1 1/2	1/8	3/16	PSR-8	12	28.32	38.1	6.4	4.8	MPSR-12
5/8	1.125	1 5/8	5/16	1/4	PSR-10	16	28.77	41.3	8.0	6.4	MPSR-16
3/4	1.500	1 3/4	3/8	1/4	PSR-12	20	38.72	44.5	9.5	6.4	MPSR-20
1	1.750	2 1/8	1/2	1/4	PSR-16	25	44.22	54.0	12.7	6.4	MPSR-25
1 1/4	2.125	2 1/2	9/16	5/16	PSR-20	30	46.85	54.0	12.7	6.4	MPSR-30
1 1/2	2.500	3	11/16	3/8	PSR-24	40	64.44	76.2	17.5	9.5	MPSR-40

PRE-DRILLED ALUMINUM SHAFT SUPPORT RAILS

Inch and Metric

Mate With Type PD Shafts

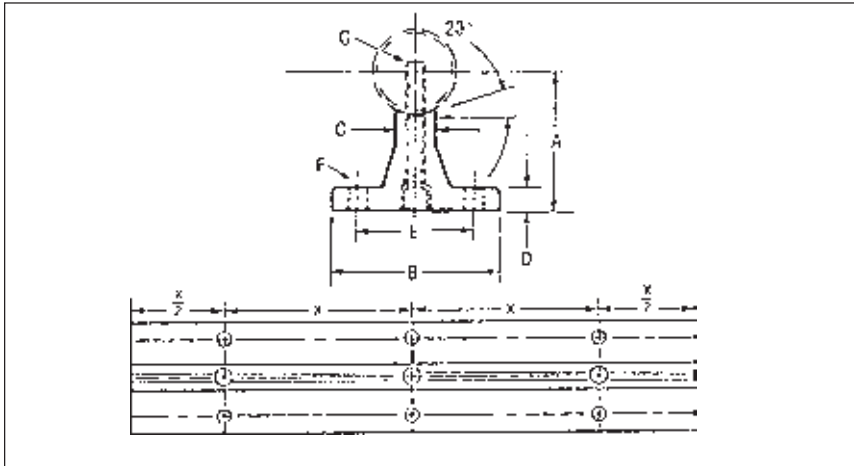

ORDERING INFORMATION

When ordering standard 24" support rails with mounting holes, order by part number only (for example PSR-20-PD). If a shorter length is required, specify part number and exact length (for example PSR-20 - PD, 18" long). We provide cutting service at a slight additional charge.

Use "M" prefix for metric sizes.

Pre-drilled support rails are stocked for immediate delivery in standard 24" (600 mm) lengths, but can easily be cut to size. When longer shafts are to be supported, the rails can be continuously mounted end-to-end or intermittently mounted to any desired length.

Inch Sizes

Nominal Shaft Diameter (inch)	A ± .002	B	C	D	E	F Hole	G		X ± .010	Part Number
							Screw	Hole		
1/2	1.125	1 1/2	1/4	3/16	1	.169	6-32 x 7/8	.169	4	PSR-8-PD
5/8	1.125	1 5/8	5/16	1/4	1 1/8	.193	8-32 x 7/8	.193	4	PSR-10-PD
3/4	1.500	1 3/4	3/8	1/4	1 1/4	.221	10-32 x 1 1/4	.221	6	PSR-12-PD
1	1.750	2 1/8	1/2	1/4	1 1/2	.281	1/4-20 x 1 1/2	.281	6	PSR-16-PD
1 1/4	2.125	2 1/2	9/16	5/16	1 7/8	.343	5/16-18 x 1 3/4	.343	6	PSR-20-PD
1 1/2	2.500	3	11/16	3/8	2 1/4	.343	3/8-16 x 2	.406	8	PSR-24-PD

Metric Sizes

Nominal Shaft Diameter (mm)	A ± .08	B	C	D	E	F Hole	G		X ± .25	Part Number
							Screw	Hole		
12	28.32	38.1	6.4	4.8	25.4	4.8	M4 x .7	4.8	120	MPSR-12-PD
16	28.77	41.3	8.0	6.4	28.6	5.8	M5 x .8	5.8	150	MPSR-16-PD
20	38.72	44.5	9.5	6.4	31.8	6.8	M6 x 1.0	6.8	150	MPSR-20-PD
25	44.22	54.0	12.7	6.4	38.1	6.8	M8 x 1.25	8.8	200	MPSR-25-PD
30	46.85	54.0	12.7	6.4	38.1	6.8	M10 x 1.50	8.8	200	MPSR-30-PD
40	64.44	76.2	17.5	9.5	57.2	8.8	M10 x 1.50	10.8	200	MPSR-40-PD

Mounting hole patterns for various sizes are shown in tables above. The alignment and location of holes are ±.010 (±0.25 mm) non-cumulative.

SHAFTS AND SUPPORT RAILS ASSEMBLIES

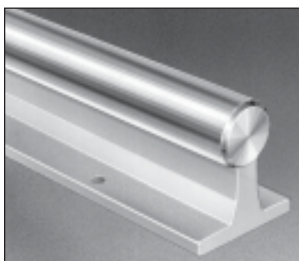

PIC can supply shafts and rails as complete assemblies in 24" length (600 mm) as standard sizes. Other lengths will be quoted on request.

ORDERING INFORMATION

Order standard 24" long shaft and rail assembly as follows:

C1060 Hardened Steel Shaft A10-X-SR
 440C Stainless Steel Shaft A12-X-SR
 303 Stainless Steel Shaft A11-X-SR

"X" = Size Code for Inch Series.

Use diameter for Metric Series.

"M" = Prefix For Metric Sizes

Inch	
Nominal	Size Code
1/2	8
5/8	10
3/4	12
1	16
1 1/4	20
1 1/2	24

SHAFT SUPPORT BLOCKS / HANGERS

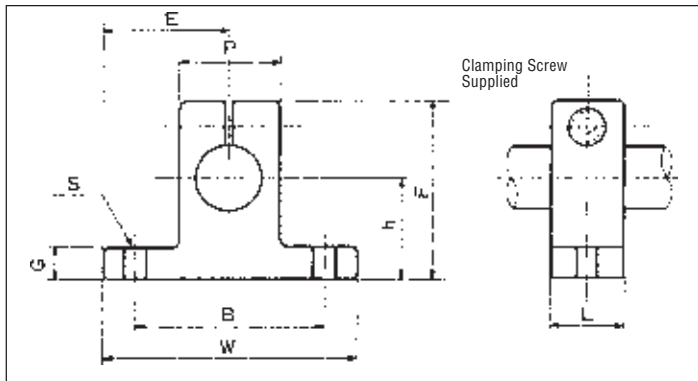

Material: Cast Aluminum

Inch Shaft Support Blocks / Hangers

Shaft Diameter (inch)	Dimensions (inch)										Part No.
	h ±.001	E ±.005	W	L	F	G	P	B ±.01	S Hole	Bolt #	
.250	.6875	.7500	1.500	.500	1.063	.250	.500	1.125	.156	#6	SHA-4
3/5	.7500	.8125	1.625	.563	1.187	.250	.688	1.250	.156	#6	SHA-6
.500	1.0000	1.0000	2.000	.625	1.625	.250	.875	1.500	.188	#8	SHA-8
.625	1.0000	1.2500	2.500	.688	1.750	.313	1.000	1.675	.218	#10	SHA-10
.750	1.2500	1.2500	2.500	.750	2.063	.313	1.250	2.000	.218	#10	SHA-12
1.000	1.5000	1.5315	3.063	1.000	2.500	.375	1.500	2.500	.281	#12	SHA-16
1.250	1.7500	1.8750	3.750	1.125	3.000	.438	2.000	3.000	.345	#16	SHA-20
1.500	2.0000	2.1875	4.375	1.250	3.437	.500	2.250	3.500	.345	#16	SHA-24

Metric Shaft Support Blocks / Hangers

Shaft Dia. (mm)	Dimension (metric sizes)										Part Number
	h ±.02	E ±.05	W	L	F	G	P	B	S	Bolt #	
12	23	21	42	14	37.5	6	20	32	5.5	M5	MSHA-12
16	27	24	48	18	44.0	8	25	38	5.5	M5	MSHA-16
20	31	30	60	20	51.0	10	30	45	6.6	M6	MSHA-20
25	35	35	70	24	60.0	12	38	56	6.6	M6	MSHA-25
30	42	42	84	28	70.0	12	44	64	9.0	M8	MSHA-30
40	60	57	114	36	96.0	15	60	90	11.0	M10	MSHA-40

PRECISION SHAFT HANGERS — 1/4 to 1 Shaft Diameters Machined

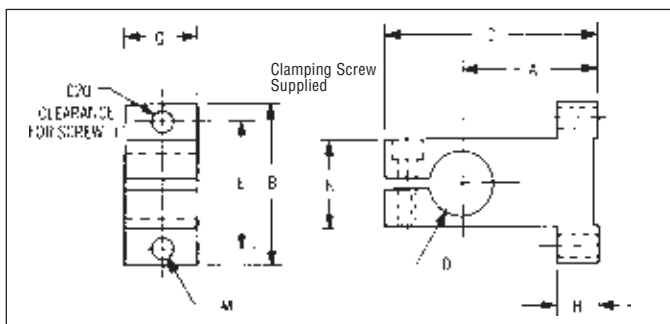

A ±.001	B	C	D +.005 -.000	E	G	H	I	K	Part No.
.562	1.125	1.125	2500	.875	3/8	3/16	#6	5/8	S7-1
.667	1.250	1.313	3750	.937	1/2	3/16	#8	5/8	S7-2
.750	1.500	1.438	5000	1.125	5/8	1/4	#10	3/4	S7-3
1.000	1.750	1.750	6250	1.375	3/4	3/8	#10	7/8	S7-4
1.062	1.875	1.875	7500	1.500	7/8	1/2	1/4	1	S7-5
2.125	2.125	3.063	13000	1.750	1	5/8	1/4	1 1/4	S7-6

Material: Machined Aluminum

Finish: Black Anodize

FLANGED TYPE LINEAR BEARINGS

Inch and Metric

Recirculating Ball

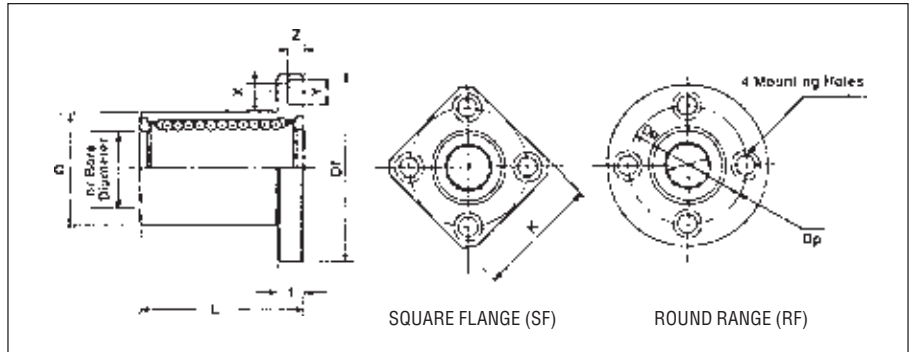

- Requires no housing, thus reducing costs
- Requires little installation space
- Ensures high accuracy upon replacement
- Retains excellent rigidity

Material:

Balls: 52100 Chrome Steel
Outer Housing: 52100 Chrome Steel

Ball Retainer: Resin For Low Noise Performance
End Caps: 1018 Steel

Inch Sizes

Boundary Dimensions and Tolerance											Eccentricity (inch)	Square-ness (inch)	Basic Dynamic Load Rating (C kgf)	Basic Static Load Rating (Co kgf)	Shaft Diameter (inch)	Part No.* Add Suffix RF or SF		
dr (inch)	Tolerance (inch)	D (inch)	Tolerance (inch)	L (inch)	Tolerance (inch)	Flange												
						DF (inch)	K (inch)	L (inch)	Op (inch)	X (inch)	Y (inch)	Z (inch)						
.7500		.8000	0 - .00045	.7500		1.7500	1.0090	0.219	0.750	1.560	.2500	14.0	.0005	.0005	21	27	2500	PL-4
.3750	0	.6250	0	.8750	0	1.5000	1.2500	.2500	1.0620	.1875	29.70	1.720			23	32	3750	PL-6
.5000	-.00040	.8750	-.00050	1.2500	-.008	1.7500	1.3750	.2500	1.312	.1875	29.70	1.720			52	79	5000	PL-8
.6250		1.1250		1.5000		2.0000	1.5000	.2500	1.5620	.1875	29.70	1.720			79	120	.6250	PL-10
.7500	0	1.2500	0	1.6250		2.1875	1.6875	.3125	1.7180	2.167	34.40	.2030	.0006	.0006	88	140	.7500	PL-12
1.0000	-.00040	1.5625	-.00065	2.2500	0	2.5000	2.0000	.3125	2.0310	2.187	34.40	.2030			100	160	1.0000	PL-16
1.2500	0	2.0000	0	2.6250		3.1250	2.5000	.3750	2.5625	2.812	40.60	.2656	.0008	.0008	150	280	1.2500	PL-20
1.5000	-.00050	2.3750	0.00075	3.0000	-.012	3.7500	3.0000	.5000	3.0625	3.440	50.00	3.280			220	410	1.5000	PL-24

*Note: To order round flange type use "RF" suffix in part number.
To order square flange type use "SF" suffix in part number.

Example: PL-8RF (Round Flange)
PL-8SF (Square Flange)

Metric Sizes

Boundary Dimensions and Tolerance											Eccentricity (mm)	Square-ness (mm)	Basic Dynamic Load Rating (C kgf)	Basic Static Load Rating (Co kgf)	Shaft Diameter (mm)	Part No.* Add Suffix RF or SF		
dr (mm)	Tolerance (mm)	D (mm)	Tolerance (mm)	L (mm)	Tolerance (mm)	Flange												
						DF (mm)	K (mm)	L (mm)	Op (mm)	X (mm)	Y (mm)	Z (mm)						
5		12	0	22		28	27	5	20	36	6	3.1	12	12	27	27	5	MPL-5
9	+8	16	8	25		32	25	5	24	35	6	3.1			27	41	9	MPL-8
12	0	22	0	32	0	42	32	5	32	45	7.5	4.1			52	79	12	MPL-12
16	+9	25	-9	36	-.200	46	35	5	36	45	7.5	4.1			59	87	16	MPL-16
20	-1	32	0	45		54	42	8	43	55	9	5.1	15	15	88	140	20	MPL-20
25	+11	40	-11	58	0	62	50	9	51	55	9	5.1			100	160	25	MPL-25
30	-1	47	-11	68		76	60	10	62	66	11	6.1			150	280	30	MPL-30
40	+13 -2	62	0 -13	80	-300	98	75	13	78	9	14	8.1	17	17	220	410	40	MPL-40

*Note: To order round flange type use "RF" suffix in part number.
To order square flange type use "SF" suffix in part number.

Example: MPL-12RF (Round Flange)
MPL-12SF (Square Flange)

RECIRCULATING BALL LINEAR BEARINGS

Instrument Series

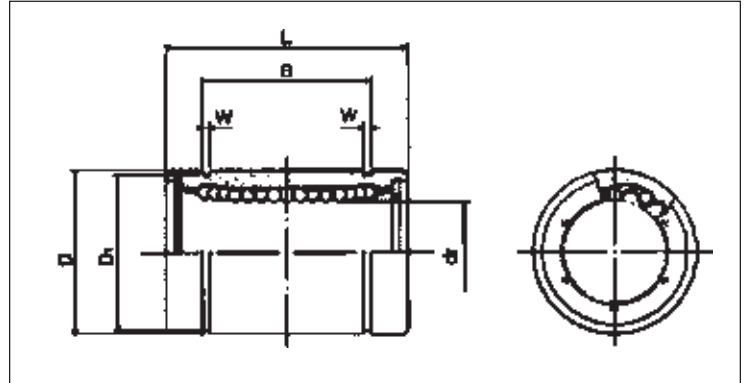

Material: Corrosion Resistant Materials.
 Balls: Stainless Steel Outer
 Housing: Hardened Stainless Steel Ball
 Retainer: Seamless Resin
 Eccentricity: 0.0003"

Nominal Shaft Diameter	Ball Circuit	Weight oz.	dr Tol. +0 -0.00035	D	L Tol. +0 -0.008	B Tol. +0 -0.008	W	D1	Radial Clearance	Basic Load Rating		Part Number
										Dynamic C lbs.	Static Co lbs.	
0.1250	4	0.099	0.1250	0.3125	0.500	0.3681	0.0280	0.2902	-0.00008	13.2	17.1	PLS-2
0.1875	4	0.127	0.1875	0.3750	0.562	0.4311	0.0280	0.3520	-0.00010	20.5	24.7	PLS-3
0.2500	4	0.335	0.2500	0.5000	0.750	0.5110	0.0391	0.4687	-0.00010	46.3	59.6	PLS-4

SHAFTING FOR INSTRUMENT SERIES

Linear Bearings

Material and Hardness:
 C-1060 case hardened to Rockwell 60-64C
 440C Stainless Steel (or equivalent) case hardened to Rockwell 52-56C
 Case Depth: 0.03" minimum
 Finish: Between 10 -16 micro-inches RMS
 Length Tolerances: $\pm 1/16$ "
 Straightness: .001" - .002" per foot

Nominal Dia. (inches)	Size & Tol. (inches)	Max. Length (inches)	C-1060 Steel Part Number	440 C Stainless Part Number
0.1250	.1248/.1245	12	ACS10-2	A12-2
0.1875	.1873/.1870	16	ACS10-3	A12-3
0.2500	.2498/.2494	48	ACS10-4	A12-4

How to Order

When ordering shaft that do not require any special machining, simply add required length in inches to Part Number.
 Example: A12-2-6".

RECIRCULATING BALL LINEAR BEARINGS

Inch and Metric

Closed, Adjustable and Open Styles

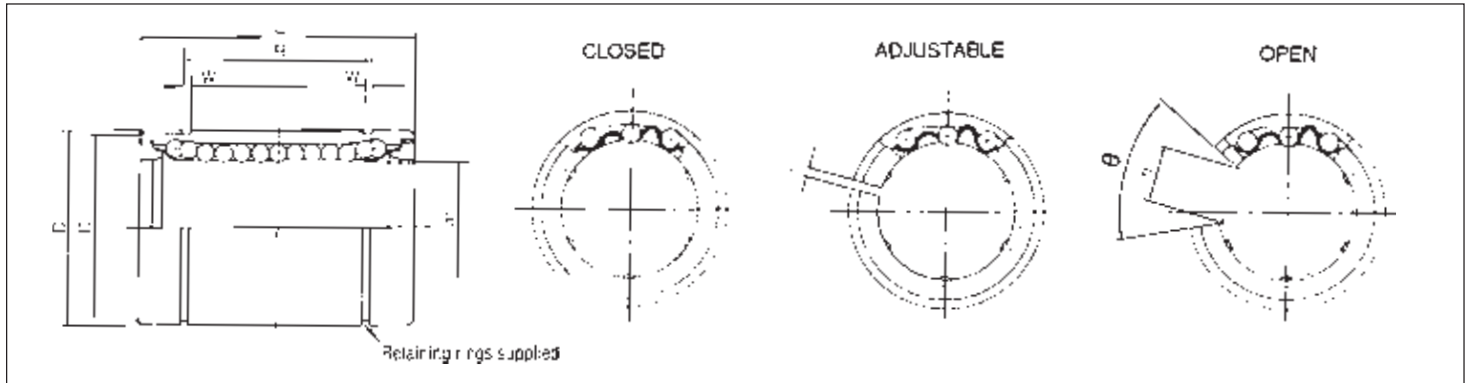

Material: Balls: 52100 Chrome Steel
 Outer Housing: 52100 Steel
 Ball Retainer: Resin
 End Caps: 1018 Steel

Shafting: Select From C-1060 Steel (PIC Series A10)
 or 440C Stainless Steel (PIC Series A12)

Boundary Dimensions and Tolerance (inch sizes)												Basic Dynamic Load Rating (C lbs)	Basic Static Load Rating (Co lbs)	Nominal Shaft diameter (inch)	Part No.*	
dr (inch)	Tolerance (inch)	D (inch)	Tolerance (inch)	L (inch)	Tolerance (inch)	B (inch)	Tolerance (inch)	W (inch)	D ₁ (inch)	h (inch)	h ₁ (inch)					α
2500	0	5300	0.0045	7500	0	5110	0	.3390	4657	—	—	—	46	60	250	PL-4**
3750	-0.0040	5250	0	8750	0	6358	0	3390	5880	—	—	—	51	71	375	PL-6**
5000		8750		12500		9625		0	0458	8209	.06	.340	80°	115	176	500
625	0	1125	0	15000	-0.008	11039	-0.008	.0553	10690	.35	.375	80°	174	265	625	PL-10
7500		12500		16250		11557		0	.0559	11760	.06	.437	60°	194	308	750
10000	-0.0040	15625	-0.0065	22500	0	17547	0	.0679	14557	.06	.562	50°	220	353	1000	PL-16
12500	0	20000	0	26250		20047		0	.0679	16559	.10	.625	50°	353	616	1250
15000	-0.0050	20750	-0.0075	30000	-0.012	24118	-0.012	.0859	22389	.12	.750	50°	490	904	1500	PL-24

*To order: Adjustable bearing — Use No. PA - Size Code. Open bearing — Use No. PO - Size Code.
 **Closed Style Only

Boundary Dimensions and Tolerance (metric sizes)												Basic Dynamic Load Rating (C N)	Basic Static Load Rating (Co N)	Nominal Shaft diameter (mm)	Part No.*	
dr (mm)	Tolerance (μm)	D (mm)	Tolerance (μm)	L (mm)	Tolerance (μm)	B (mm)	Tolerance (μm)	W (mm)	D ₁ (μm)	h (mm)	h ₁ (mm)					α
5	+8	12	0	22	0	14.5	0	.1	115	1	—	—	206	265	5	MPL-5
8	0	16	-6	25	0	16.5	0	11	15.2	1	—	—	265	402	8	MPL-8
12		22		0		32		22.0	0	13	21	1.5	75	70°	510	784
16	-9	26	9	38	-200	24.5	200	13	24.9	1.5	10	70°	578	892	16	MPL-16
20	-1	32	0	45	0	31.5	0	1.6	30.3	2	10	60°	862	1370	20	MPL-20
25		40		-1		58		44.1	0	.65	37.5	2	12.5	60°	980	1570
30	-1	47	0	68	0	52.1	0	1.85	44.5	2	12.5	50°	1570	2740	30	MPL-30
40	-13 -2	62	0 -13	80	-330	60.9	-330	2.15	53	3	16.8	50°	2160	4020	40	MPL-40

*To order: Adjustable bearing — Use No. MPA - Size Code. Open bearing — Use No. MPO - Size Code.

SELF-ALIGNING BEARINGS

Inch and Metric

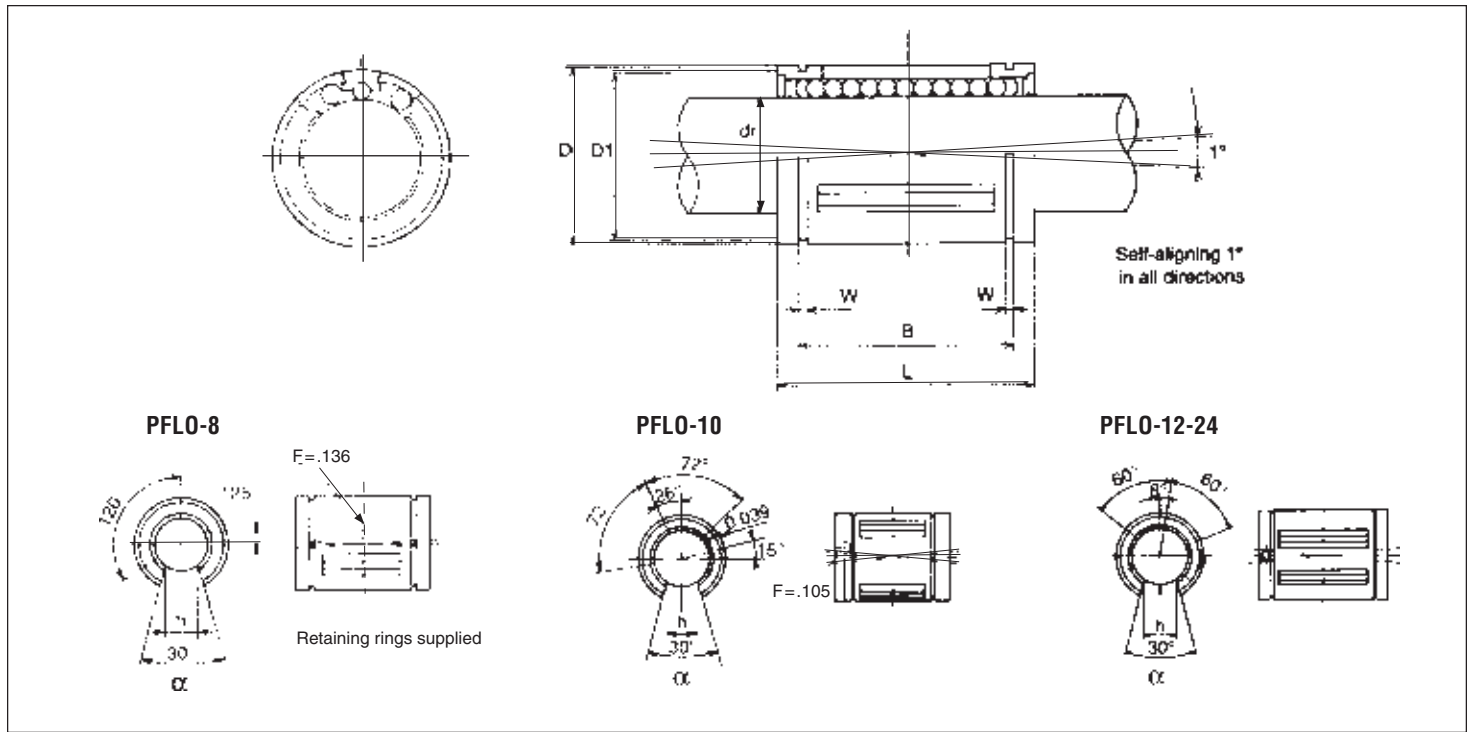

Inch Sizes

Nominal Shaft Diameter	Working Bore		O.D. Nominal (D)	Length		Retaining Rings			Open Type (h)	Load Ratings (lbs.)	F	Dynamic Part Number*
	(dr)	Tolerance		(L)	Tolerance	(B)	(W)	(D1)				
1/4	0.2500	-0.0005	0.500	0.750	-0.015	0.515	0.039	0.4687	—	60	—	PFL-4
3/8	0.3750	-0.0005	0.625	0.875	-0.015	0.703	0.039	0.588	—	95	—	PFL-6
1/2	0.5000	-0.0005	0.875	1.250	-0.020	1.032	0.0459	0.8209	0.313	230	.136	PFL-8
5/8	0.6250	-0.0005	1.125	1.500	-0.020	1.112	0.0559	1.059	0.375	400	.105	PFL-10
3/4	0.7500	-0.0005	1.250	1.625	-0.020	1.272	0.0559	1.176	0.438	470	.136	PFL-12
1	1.0000	-0.0005	1.5625	2.250	-0.020	1.886	0.0679	1.4687	0.563	850	.136	PFL-16
1 1/4	1.2500	-0.0006	2.000	2.625	-0.025	2.011	0.0679	1.8859	0.625	1230	.201	PFL-20
1 1/2	1.5000	-0.0006	2.375	3.000	-0.030	2.422	0.0859	2.2389	0.750	1480	.201	PFL-24

* For open type bearings, insert "O" after PFL. Example: Part number for an open 1/2" bearing is PFL0-8.

Note: Open bearing should use pillow blocks with 'S' suffix.

Metric Sizes

Working Bore		O.D.		Length		Retaining Rings			Open Type (h)	Open Type Angle (α)	Dynamic Load Ratings (N)	Part Number*
(dr)	Tolerance (μm)	(D)	Tolerance (μm)	(L)	Tolerance (μm)	(B)	(W)	(D1)				
12	+8	22	-8	32	-200	22.9	1.3	21	6.5	66	650	MPFL-12
16	+9	26	-9	36		24.9	1.3	24.9	9.0	68	800	MPFL-16
20	-1	32	-11	45		31.5	1.6	30.3	9.0	55	1500	MPFL-20
25	+11	40	-11	58	-300	44.1	1.85	37.5	11.5	57	2500	MPFL-25
30	-1	47	-11	68		52.1	1.85	44.5	14.0	57	3200	MPFL-30
40	+13 -2	62	-13	80		60.6	2.15	59	19.5	56	5500	MPFL-40

* For open type bearings, insert "O" after MPFL. Example: Part number for an open 16mm bearing is MPFL0-16.

SELF LUBRICATING PLASTIC LINEAR BEARINGS

Closed, Adjustable and Open Styles

Inch and Metric

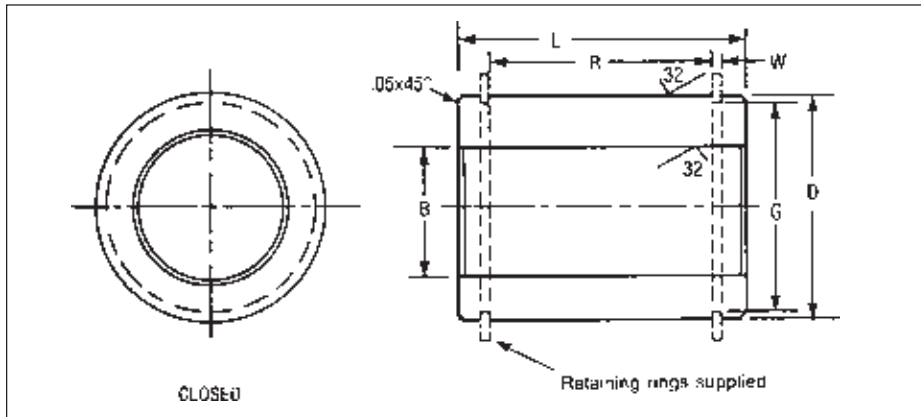

Material: Self Lubricated Engineered Plastic
 PV = 16000 PSI-FPM Closed Bearings
 = 10000 PSI-FPM Open Bearings
 Maximum Speed: 200 FPM (unlubricated)
 Max P: 750 PSI (static)
 Hardness Durometer: Shore "D" 75
 Coefficient of Friction: 0.2

$$P = \frac{\text{Load (lbs.)}}{\text{I.D.} \times L \text{ (in.)}}$$

$$V_{\text{FPM}} = \frac{\text{Travel Distance (ft)}}{\text{Time (minutes)}}$$

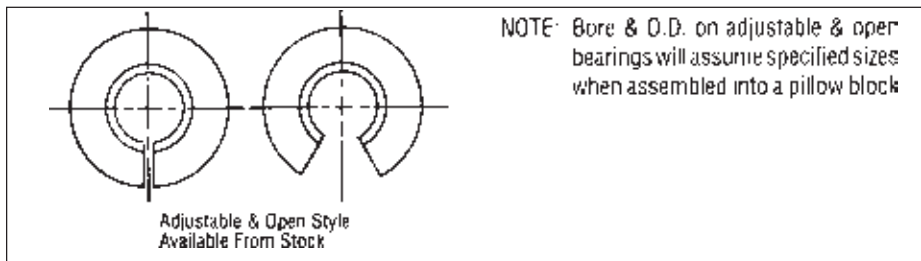

- Maintenance free — self lubricating material — quiet operation
- Improved reliability in hostile environments. Resistant to galvanic corrosion
- Does not gall or Brinell mating shaft
- Interchangeable with all linear ball bearings
- Use with all hard or "soft" stainless steel shafting

Inch Sizes

Bore B (inch)	Outside Dia. D	L ±.010	R ±.015	W +.010 -.000	G +.010 -.000	Max Shaft Diameter	Recommended Fits		Part Number* (Closed)
							Normal +.0005	Press +.0005	
.253 + .002	.5000 - .0010	3/4	.437	.039	.468	.2490	.5000	.4990	PLC-4**
.378 + .002	.6250 - .0010	7/8	.562	.039	.588	.3740	.6250	.6240	PLC-6**
.504 + .003	.8750 - .0015	1 1/4	.875	.046	.821	.4995	.8750	.8740	PLC-8
.629 + .003	1.1250 - .0015	1 1/2	1.000	.056	1.063	.6245	1.125	1.124	PLC-10
.755 + .003	1.2500 - .0015	1 5/8	1.062	.056	1.176	.7495	1.2500	1.2490	PLC-12
1.005 + .004	1.5625 - .0020	2 1/4	1.625	.068	1.468	.9995	1.5625	1.5615	PLC-16
1.255 + .004	2.0000 - .0020	2 5/8	1.875	.068	1.886	1.2490	2.0000	1.9990	PLC-20
1.505 + .004	2.3750 - .0020	3	2.240	.086	2.239	1.4990	2.3750	2.3740	PLC-24

* Substitute A or O for C to denote adjustable or closed style, respectively. For example, PLA = Adjustable style. PLO = open style, PLC = closed style

** Closed only

Metric Sizes

Bore B (mm)	Outside Dia. D	L ±.30	R ±.40	W +.30	G +.30	Max Shaft Diameter	Recommended Fits		Part Number* (Closed)
							Normal +.012	Press +.012	
5	12 - .03	22	12	1.1	11.5	5	12.0	11.98	MPLC-5**
8	16 - .03	25	14	1.1	15.0	8	16.0	15.97	MPLC-8**
12	22 - .03	32	20	1.3	21.0	12	22.0	21.97	MPLC-12
16	26 - .04	36	22	1.3	25.0	16	26.0	25.96	MPLC-16
20	32 - .04	45	28	1.6	30.5	20	32.0	31.96	MPLC-20
25	40 - .05	58	40	1.9	37.5	25	40.0	39.96	MPLC-25
30	47 - .05	68	48.4	1.9	44.5	30	47.0	46.96	MPLC-30
40	62 - .05	80	56.3	2.1	59.0	40	62.0	61.96	MPLC-40

* Substitute A or O for C to denote adjustable or closed style, respectively. For example, MPLA = Adjustable style. MPLO = open style, MPLC = closed style

** Closed only

PIC CERAMIC COATED LINEAR BEARINGS

Linear Rotary Motion Bearings

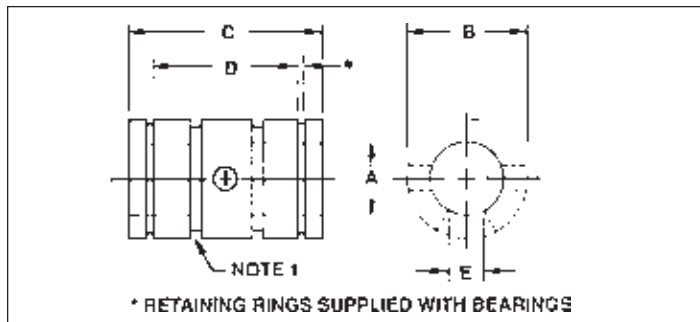

1. Self aligning mounting up to 2° available, consult factory.
2. Larger size bearings available, consult factory.

DESIGN ADVANTAGES

- Economical alternative to linear ball bearings — interchangeable with PL & PO series.
- Eliminates shaft brinelling
- Designed for linear and rotary motion
- Quiet operation
- Lightweight
- Vacuum Application up to 10⁻¹⁰ Torr
- High load capacity
- Outstanding wear, prolonged bearing and shaft life
- Corrosion resisting
- Electrically insulating
- One piece construction — no balls to damage or jam mechanisms
- Special shapes and sizes available, consult factory

PERFORMANCE DATA

Maximum PV (continuous) 40,000
 Maximum linear velocity: 2000 SFM
 Maximum Load: 5000 PSI
 Coefficient of Friction: .04 (with recommended shaft and lithium stearate grease)
 Material: Special aluminum alloy with a proprietary low friction coating (RC 85)
 Recommended shaft: 58-63 Rockwell "C", 8-16 RMS
 Electrical Resistance (flat surface): 1200 VDC
 Insulation Resistance: above 250 Megohms
 Lubrication: Essential to achieve maximum performance. Lithium Stearate grease is recommended. (Silicone fluid lubricants have a negative effect on performance.)

Closed Series

Bore	O.D. B	C	D	Recommended			Part No.
				Shaft PIC Part No.	Dia. +.0000 - .0005	Pillow Block PIC Part No.	
+ .001 - .000	+ .000 - .001	+ .000 - .015	± .010				
2505	5030	750	437	A10-4	2490	\$5-1	BLC-04
3755	6250	875	567	A10-6	3740	\$5-2	BLC-06
5005	8750	1,250	875	A10-8	4990	\$5-3	BLC-08
6255	1,250	1,500	1,000	A10-10	6240	\$5-4	BLC-10
7508	1,2500	1,625	1,052	A10-12	7490	\$5-5	BLC-12
1,0008	1,5625	2,250	1,625	A10-16	9990	\$5-6	BLC-16

Open Series

Bore	Housing Bore	C	D	E	Recommended			Part No.
					Shaft PIC Part No.	Dia. +.0000 - .0005	Pillow Block PIC Part No.	
+ .001 - .000	+ .000 - .001	+ .000 - .015	± .010	+ .020 - .000				
5005	8750	1,250	875	512	A10-8	4990	\$5-13	BLO-08
6255	1,1250	1,500	1,000	375	A10-10	6240	\$5-14	BLO-10
.7508	1,2500	1,625	1,052	438	A10-12	7490	\$5-15	BLO-12
1,0008	1,5625	2,250	1,625	563	A10-16	9990	\$5-16	BLO-16

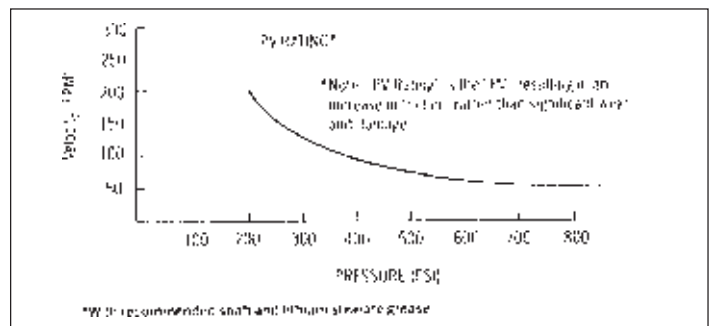

PIC METRIC CERAMIC COATED LINEAR BEARINGS

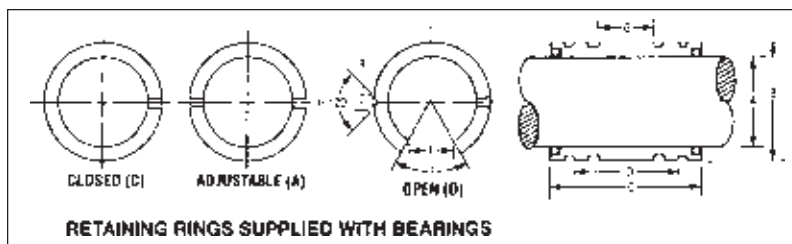

These bearings are produced to ISO standards and are exactly interchangeable dimensionally with metric ball bushings currently produced in Europe. Retention is achieved through the use of a set screw of suitable point dimension to be accepted into the retention hole illustrated. Retention hole diameters are listed in column R, Metric PIC Linear Bearings are available with or without integral seals. Since the seals are recessed, all bearings are the same length. There's no need to allow extra space for sealed bearings.

Working Bore	Outside Dia.	Length	Tot. Tol. - .000	Max Shaft Dia.	Housing Bore Dia.	Open (D)	Adj. (A)	Open (D) deg.	Open (D)	Part No.*	
											Tol. + .000
A	B	C	D	E	F	G	H	I	J	K	
5	12	22	0.038 - 0.065	5	12	—	—	—	4	—	MBL()-5
8	16	25	0.038 - 0.065	8	16	—	—	—	6	—	MBL()-8
12	22	32	0.038 - 0.065	12	22	7.5	2.5	78	8	2.5	MBL()-12
16	26	36	0.038 - 0.065	16	26	10.8	3	78	12	3	MBL()-16
20	32	45	0.047 - 0.074	20	32	10.8	3.5	60	14	3.5	MBL()-20
25	40	58	0.047 - 0.074	25	40	13.2	4.5	60	16	4.5	MBL()-25

*Note: MBL-C-X = Closed; MBL-A-X = Adjustable; MBL-O-X = Open

LINEAR BEARING HOUSING

For Closed Linear Bearings

MATERIAL: Aluminum
FINISH: Black Anodize

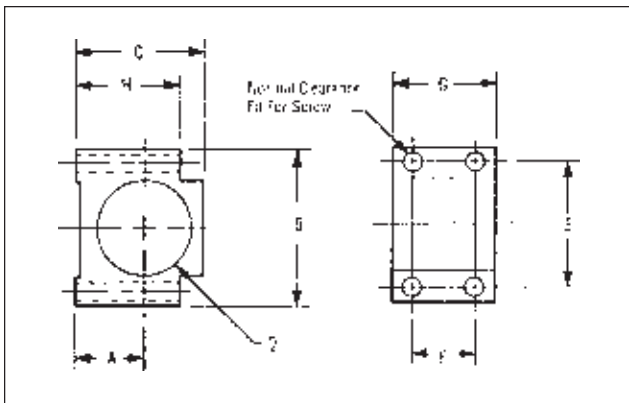

For Shaft Size	Q Bore +.001 -.000	A ±.001	B ±.030	C ±.025	E ±.005	F ±.015	G +.000 -.005	H ±.025	MTG Screw	Part No.
.250	.5000	.437	1.125	.812	.875	—*	.427	.656	#6	S5-1
.375	.6250	.500	1.250	.937	1.000	—*	.552	.781	#6	S5-2
.500	.8750	.625	1.500	1.187	1.187	.562	.865	1.000	#6	S5-3
.625	1.1250	.762	1.750	1.500	1.425	.700	.986	1.300	#8	S5-4
.750	1.2500	.875	1.875	1.656	1.562	.750	1.048	1.437	#8	S5-5
1.000	1.5625	1.000	2.375	1.937	2.000	1.250	1.610	1.625	#10	S5-6
1.250	2.0000	1.312	2.750	2.500	2.375	1.500	1.860	2.062	#10	S5-7
1.500	2.3750	1.625	3.750	3.180	3.281	1.750	2.235	2.750	1/4"	S5-8

* 2 mounting holes centered

For Adjustable Linear Bearings

MATERIAL: Aluminum
FINISH: Black Anodize

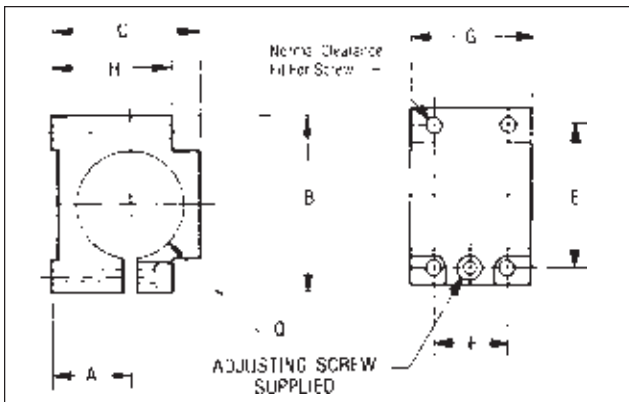

For Shaft Size	Q Bore +.001 -.000	A ±.001	B ±.030	C ±.025	E ±.005	F ±.015	G +.000 -.005	H ±.025	MTG Screw	Part No.
.500	.8750	.625	1.500	1.187	1.187	.562	.865	1.000	#6	S8-3
.625	1.125	.762	1.750	1.500	1.425	.700	.986	1.300	#8	S8-4
.750	1.2500	.875	1.875	1.656	1.562	.750	1.048	1.437	#8	S8-5
1.000	1.5625	1.000	2.375	1.937	2.000	1.250	1.610	1.625	#10	S8-6
1.250	2.0000	1.312	2.750	2.500	2.375	1.500	1.860	2.062	#10	S8-7
1.500	2.3750	1.625	3.750	3.187	3.350	1.750	2.235	2.750	1/4"	S8-8

For Open Linear Bearings

MATERIAL: Aluminum
FINISH: Black Anodize

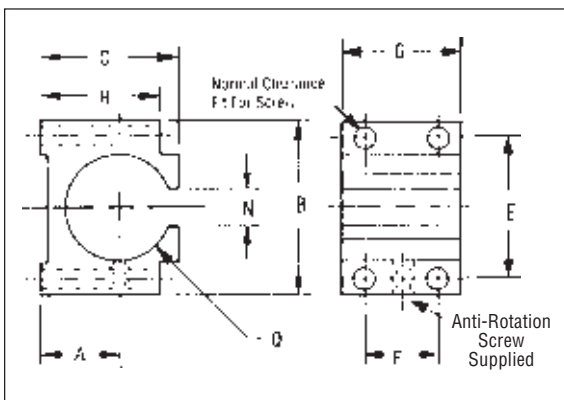

For Shaft Size	Q Bore +.001 -.000	A ±.001	B ±.030	C ±.025	E ±.005	F ±.015	G +.000 -.005	H ±.025	MTG Screw	N ±.02	Std. Style	Self-Aligning Style	
											Part No.	G +.000 -.005	Part No.
.500	.8750	.625	1.500	1.062	1.187	.562	.865	1.000	#6	.406	S5-13	.930	S5-13S
.625	1.1250	.762	1.750	1.250	1.425	.700	.986	1.250	#8	.781	S5-14	.990	S5-14S
.750	1.2500	.875	1.875	1.562	1.562	.750	1.048	1.437	#8	.469	S5-15	1.150	S5-15S
1.000	1.5625	1.000	2.375	1.687	2.000	1.250	1.610	1.625	#10	.781	S5-16	1.740	S5-16S
1.250	2.0000	1.312	2.750	2.250	2.375	1.500	1.860	2.062	#10	.781	S5-17	1.863	S5-17S
1.500	2.3750	1.625	3.750	3.000	3.281	1.750	2.235	2.750	1/4"	.906	S5-18	2.235	S5-18S

METRIC LINEAR BEARING HOUSING

For Closed Linear Bearings

MATERIAL: Aluminum
FINISH: Black Anodize

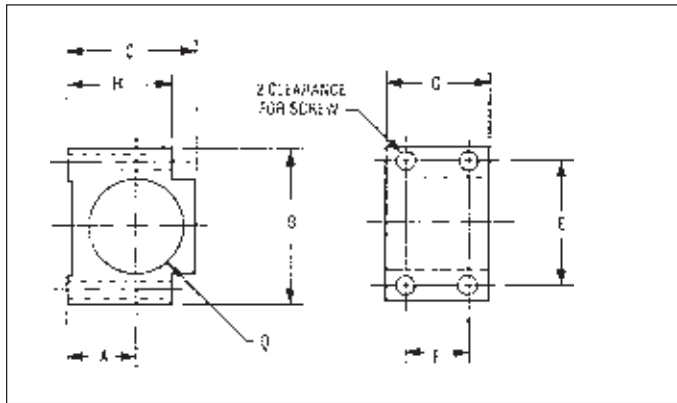

For Shaft Size	Q Bore	A	B	C	E	F	G	H	MTG SCREW	Part No.
H7	± 0.03	± 0.4	± 0.4	± 0.4	± 0.3	± 0.3	-0.3	± 0.4		
5	12	14	37	29	24	-	12	25	M3	MSC-5
8	16	16	40	35	28	-	14	31	M4	MSC-8
12	22	18	43	38	32	-	20	34	M4	MSC-12
16	26	22	53	45	40	12	22	40	M5	MSC-16
20	32	25	60	56	45	14	28	46	M5	MSC-20
25	40	30	78	61	50	22	40	53	M6	MSC-25
30	47	35	87	72	68	26	48	64	M6	MSC-30
40	62	45	108	98	85	32	56	82	M10	MSC-40

*2 Mounting Holes Centered

For Adjustable Linear Bearings

MATERIAL: Aluminum
FINISH: Black Anodize

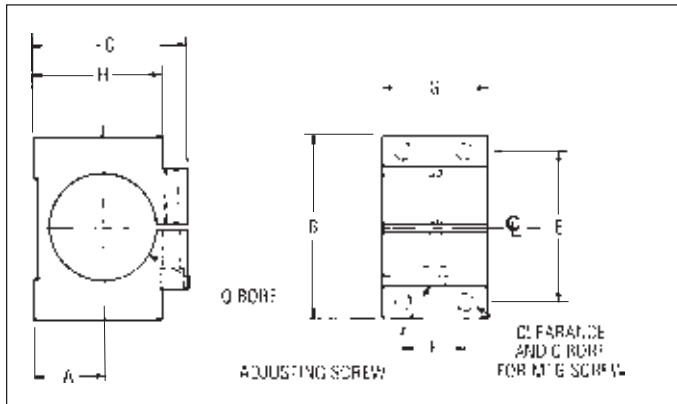

For Shaft Size	Q Bore	A	B	C	E	F	G	H	MTG SCREW	Part No.
H7	± 0.03	± 0.4	± 0.4	± 0.4	± 0.3	± 0.3	-0.3	± 0.4		
12	22	18	43	42	32	-	20	34	M4	MSA-12
16	26	22	53	56	43	12	22	40	M5	MSA-16
20	32	25	60	58	45	14	28	48	M5	MSA-20
25	40	30	78	68	60	22	40	55	M6	MSA-25
30	47	35	87	78	68	26	48	66	M6	MSA-30
40	62	45	108	98	86	32	56	82	M10	MSA-40

*2 Mounting Holes Centered

For Open Linear Bearings

MATERIAL: Aluminum
FINISH: Black Anodize

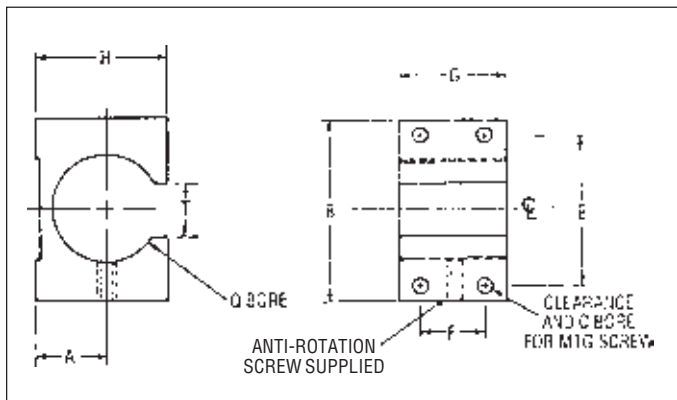

For Shaft Size	Q Bore	A	B	T	E	F	G	H	MTG SCREW	Part No.
H7	± 0.03	± 0.4	± 0.4	± 0.3	± 0.3	-0.3	± 0.4			
12	22	18	43	44	32	-	20	34	M4	MSO-12
16	26	22	53	56	43	12	22	40	M5	MSO-16
20	32	25	60	68	45	14	28	48	M5	MSO-20
25	40	30	78	79	60	22	40	55	M6	MSO-25
30	47	35	87	78	68	26	48	66	M6	MSO-30
40	62	45	108	98	86	32	56	82	M10	MSO-40

*2 Mounting Holes Centered

PRECISION RUBBER ROLLERS

■ Used in design of: Copier machine paper drives, card feeders, collators, sorters, ticket and label dispensers, and virtually any machine that moves paper, tape, etc.

■ Other bores, widths and diameters are available...inquire for price and availability.

MATERIAL: Neoprene (Urethane, 40-90 Shore A Durometer optionally available)

Clear Anodized Aluminum Hub

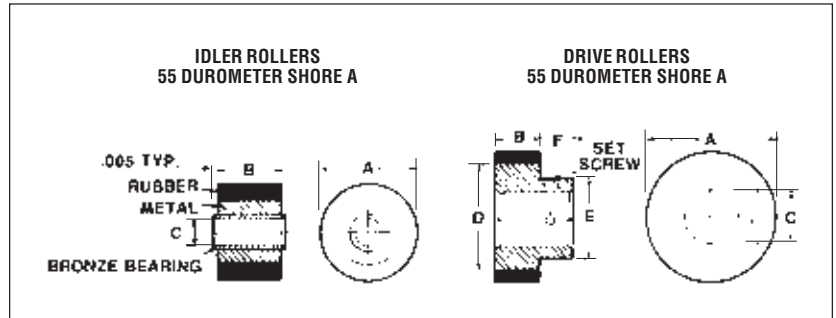

IDLER ROLLERS

Dimension			Part No.
A*	B*	C*	
500	5/8	188	RS6-0500-3
625	5/8	188	RS5-0625-3
750	3/4	251	RS6-0750-4
875	3/4	251	RS6-0875-4
1000	1/2	251	RS8-1000-4
1125	1/2	251	RS8-1125-4
1625	1/2	576	RS8-1525-6
2000	5/8	576	RS10-2000-6

Note: The face width is .010" less than the standard width.

DRIVE ROLLERS

Dimension						Set Screw	Part No.
A*	B*	C*	D*	E	F		
625	1/4	168	1/2	1/2	1/4	(1) #9-32	RD4-0625-3
750	3/8	251	1/2	1/2	1/4	(1) #8-32	RD6-0750-4
875	3/8	251	1/2	1/2	1/4	(1) #8-32	RD6-0875-4
1000	3/8	188	1/2	1/2	1/4	(1) #8-32	RD3-1000-3
1000	1/2	251	3/4	3/8	5/16	(2) #8-32	RD8-1000-4
1125	3/8	251	3/4	3/8	5/16	(2) #8-32	RD6-1125-4
1625	1/2	376	1/2	7/8	3/8	(2) #10-32	RD8-1625-6
2000	5/8	376	1/2	1	3/8	(2) #10-32	RD10-2000-6

* A, B, & C: Dimension tolerances are as follows: A = $\pm \frac{D30}{1000}$, B = $\pm .003$, C = $\pm .001$

Concentricity "A" to "C": TIR = .001"

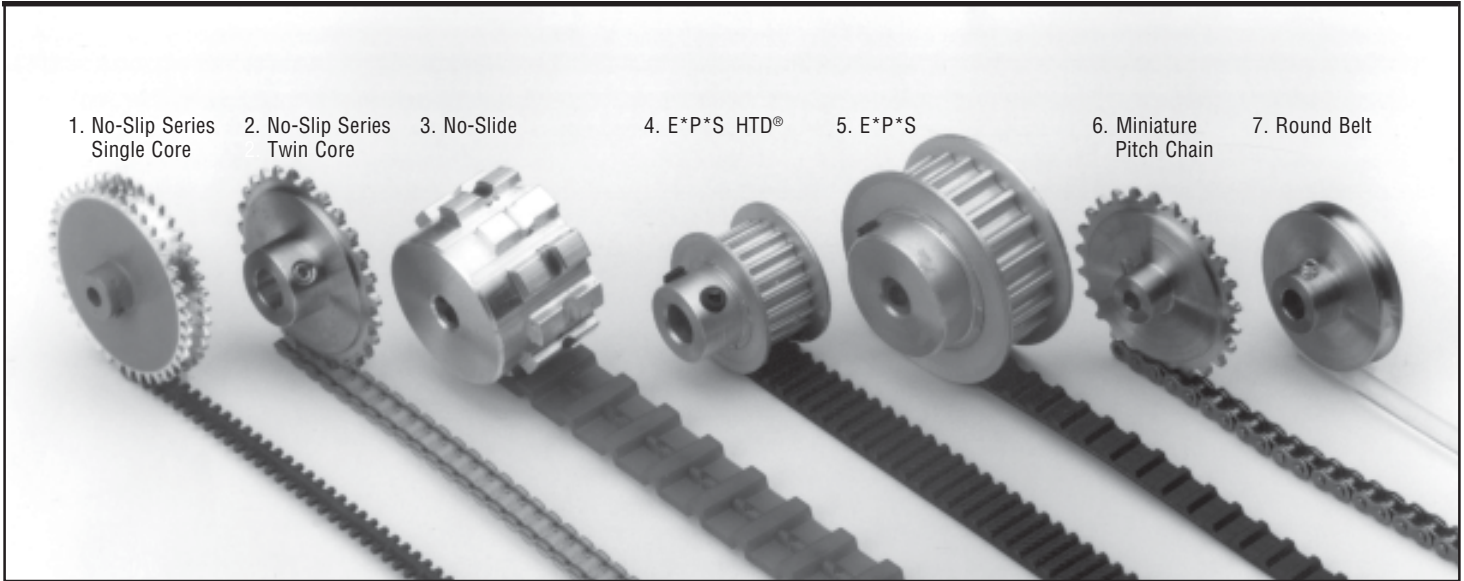

PIC Design has increased its range of belts and pulleys to provide users with the most complete line for motion control and light power transmission. Designers are no longer confined to the use of one type of drive system. PIC Design offers No-Slip™ Positioning Timing Belts, No-Slide™, E*P*S, E*P*S HTD® (Metric), Round Belts, and Miniature Chain. All come with appropriate pulleys or sprockets in various materials.

PIC Design Belts and Pulleys — A Brief Overview

NO-SLIP™ POSITIONING BELTS

No-Slip series timing belts feature many design elements. The polyurethane belts operate backlash free without lubrication and have excellent chemical and abrasion resistance for use in medical and food processing applications. Positive tooth engagement offers silent No-Slip drive. No-Slip belts are available with Aramid (Kevlar) or stainless steel cable cores in single or twin core configurations. Sprockets are available in either aluminum or stainless steel. Belts are available in lengths up to 100 feet and can be spliced in the field for added versatility.

NO-SLIDE™ TIMING BELTS

A new series of synchronous belts, combined with a grooved flangeless pulley, offers high performance timing. No-flange pulleys allow air to escape and prevents it from being trapped between the belt and flange. No-Slide belts are molded in polyurethane with a stainless steel core

(cable). They require no lubrication, handle higher load capacities than standard timing belts, are available in lengths up to 100 feet, and can be spliced in the field for added versatility.

No-Slide belts are excellent for medical, packaging, and labeling applications, and where higher load capacity is required. No-Slide pulleys are available in aluminum.

E*P*S TIMING BELTS

The E*P*S synchronous timing belt is the classical timing belt that provides positive, non-slip power transmission. These belts are available in neoprene rubber with nylon facing and a fiberglass tensile member, or urethane with a polyester tensile member as shown. A Kevlar tensile member is also available as an option. These belts are directly interchangeable with each other. The urethane belts have excellent flex characteristics which allows them to operate on pulleys with as few as 10 teeth, and ratios of 8:1 on smaller center distances.

The E*P*S line is recommended for use on office, mailing, and data processing equipment, printers, plotters, robotics, optical, and photographic equipment.

E*P*S HTD® TIMING BELTS

The E*P*S HTD® timing belts provide positive non-slip transmission at both low and high speeds and offer a higher load carrying capability than the E*P*S trapezoidal design, due to the

deeper curvilinear shape of the belt tooth. E*P*S HTD® belts can transmit more power with a more compact package as compared to E*P*S belts, and can be used in applications where shock load is evident, such as vacuum cleaners, floor polishers, sanders, centrifuges and power tools, as well as office equipment drive systems. Pulleys are available in machined aluminum.

ROUND BELTS

Round belt or O-ring drive belt systems are used in a wide variety of applications such as vibration dampening in precision mechanisms and reduction of distortion in audio equipment. Round belts also provide overload protection and can act as a clutch in certain applications. Grooved pulleys are available in stainless steel and aluminum.

MINIATURE PITCH CHAIN

Miniature pitch chains are made of non-magnetic grade stainless steel. The large joint bearing area construction permits greater loads and speeds. Precision control of chain length allows for positioning accuracy between the driver and driven sprockets. Continuous and positive lubrication is recommended for maximum life and efficiency. Sprockets are available in stainless steel and aluminum.

No-Slip and No-Slide are trademarks of Precision Industrial Components LLC. HTD is a Registered Trademark of Gates Rubber Co., Denver, CO.

TECHNICAL SECTION

Application Information

To assist customers in selecting the most appropriate flexible drive system in particular applications, PIC Design has included an Application Guide along with a Flexible Drive System Comparison Chart.

The Application Guide assists in determining the drive system suitable for your application. If your specific applications are not listed, use ones which are most similar.

The Comparison Chart will enable users to choose the drive system that will best suit a particular application. The features of these drive systems are listed so that the drive system selected will provide the most economical, maintenance-free and longest life for a particular application.

No-Slip Series belts fulfill the need for the most accurate and smoothest running drive system, while the **E*P*S Series** provides an economical solution to positive power transmission. **No-Slide timing belts** offer higher load capacities, run on no-flange pulleys, offer quiet operation, and can be used in smaller areas. **Miniature chains** offer a positive drive system for heavier duty applications, while **Round Belts** are most suitable for low-load applications not requiring positioning accuracy.

Users are encouraged to request advice or answers to questions not covered here — please don't hesitate to consult PIC Design directly.

Application Guide

	Flexible Drive Systems				
	No-Slip Belts	No-Slide Belts	Timing Belts	Chain	Round
CNC Positioning Devices	X	X	X		
Magnification & Focusing Adjustment Devices	X				
Laser Alignment Mechanisms	X				
Gear Boxes	X	X	X	X	
Paper Feeds		X	X		X
Household Appliances		X	X		X
Centrifuges		X	X		
Encoders — High Resolution Std. Resolution	X X	X	X		
Plotters	X				
Plating Room Equipment	X	X	X		X
High Speed Printers		X	X		
Manual Positioning Mechanisms	X	X	X	X	X
Power Tools, Sanders, etc.		X	X		
Machinery Drives		X	X	X	X
Advertising Displays	X	X	X	X	X
Stepper Motor Drives	X	X	X		
Business Machines	X	X	X	X	X
Audio & Visual Equipment	X	X	X	X	X

Flexible Drive System Feature Comparison

Drive Type	No-Slip	No-Slide	E*P*S (Timing)		E*P*S HTD®	Chain	Round
Catalog Series and Pitch	F, F32 - 32DP, F24C - .1309CP, FR - .1475CP, FL, FM, F20TS - 20DP, F25C - .250CP	F8B-40DP (.0816CP), F20B-.200CP, F37B-.375CP	EPS-A-.080CP, EPS-D-.200CP, EPS-J-.375CP	EPS-A-.080CP, EPS-D-.200CP, EPS-C-.0816CP (40DP)	EPS-F-3mm, EPS-G-5mm	EL-.1475CP EL25-.250CP	AF2-1/16" Thick AF3-3/32" Thick AF4-1/8 " Thick AF5-3/16" Thick AF6-1/4 " Thick
Body Material	Polyurethane	Polyurethane	Neoprene	Polyurethane	Neoprene	Stainless Steel	Polyurethane
Reinforcement	Stainless Steel or Aramid Fiber	Stainless Steel or Aramid Fiber	Fiber Glass	Polyester Fiber	Fiber Glass	—	None
Drive Both Sides of Belt	Yes ¹	No	No	No	No	Yes	Yes
Right Angle Drive	FS & FA ²	No	No	No	No	No	Yes
Resistance to Oils and Chemicals	Stainless Steel - Excellent Aramid - Good	Stainless Steel - Excellent Aramid - Good	Good	No	No	No	Yes
Pulley to Pulley ³ Misalignment	Single Core — up to 5° Double Core — up to 1/10°	Up to 1/10°	Up to 1/4°	Up to 1/4°	Up to 1/4°	No	Yes
Pulley Tooth Form	32DP — Involute 20DP, 24DP, .1475CP, .250CP — Precision Sprocket	Trapezoidal	Trapezoidal	Trapezoidal	HTD® Curvilinear	Precision Sprocket	Radius Groove
Abrasion Resistance	Excellent	Excellent	Good	Excellent	Good	Good	Excellent
Pulleys Mesh With Standard Spur Gears	32DP — Yes 20DP, 24DP — Option Available .1475CP, .250CP — No	No	No	No	No	No	No
Ability to Withstand Shock Loads	Fair	Fair	Limited	Good	Fair	Limited	Excellent
Temperature (°F)	-65 to +180 ⁴	-65 to +180 ⁴	-30 to +185	-65 to +180	-30 to +185	—	-40 to +180

Notes: **Note ¹** Driving stainless steel reinforced belts on both sides, results in a reduction of belt life due to reverse bending.

Note ² Twisting of the belt may cause the belt to wear excessively and reduce belt life. Shafts at right angles require a center distance at least 5 1/2 times the larger pulley diameter.

Note ³ Misalignment of pulleys will cause abrasive wear on the belt and reduce belt life.

Note ⁴ Practical operating temperatures are -10°F to +140°F.

NO-SLIP AND NO-SLIDE DRIVE SYSTEMS

PIC Design Guide For No-Slip and No-Slide Drive Systems

No-Slip / No-Slide	Catalog Belt Series	Pitch	Reinforcement Cable Diameter (Inch)	Positional Accuracy	Recommended Minimum Pulley Diameter (Inch)	Recommended Minimum Number Of Teeth In Mesh	Recommended Maximum Belt Operating Speed (No Load / Load) (Feet per Min.)	Recommended Maximum Operating Belt Tension (LBS)	Ultimate Static Tensile Strength For Endless Belt (LBS)
No-Slip	FA	32DP .0982CP Single Core	.032 Aramid Fiber	Excellent	.500	8	900 / 300	4-5	25
	FS		.032 Stainless Steel		.750	8	900 / 350	6-8	50
	F32BS18		.018 Stainless Steel		.500	8	800 / 350	4-5	20
	F32CS	32DP / .0982CP Double Core	.018 Stainless Steel	Very Good	.750	8	850 / 350	6-7	50
	FLA	20DP .15708CP Single Core	.032 Aramid Fiber	Good	.750	6	1100 / 500	5-6	25
	FLS		.032 Stainless Steel		.750	6	1100 / 600	10-12	50
	FMA	20DP .15708CP	.032 Aramid Fiber	Good	.750	6	1300 / 550	10-12	50
	FMS	Double Core	.032 Stainless Steel		.750	6	1300 / 700	20-25	100
	F20TS	20DP Triple Core	.032 Stainless Steel	Good	.750	6	1300 / 700	20-25	100
	FRA	.1475CP Double Core	.032 Aramid Fiber	Good	.750	6	1300 / 550	10-12	50
	FRS		.032 Stainless Steel		.750	6	1300 / 700	20-25	100
	F24CA	24DP .1309CP Double Core	.032 Aramid Fiber	Good	.750	6	1300 / 550	10-12	50
	F24CS		.032 Stainless Steel		.750	6	1300 / 700	20-25	100
	F25CA	.250CP Double Core	.032 Aramid Fiber	Good	.750	5	1300 / 550	10-12	50
	F25CS		.032 Stainless Steel		.750	5	1300 / 700	20-25	100
No-Slide	F8BS	40DP, .0816CP Single Core	.018 Stainless Steel	Good	.500	8	700 / 300	4-5	20
	F20BA	.200CP Single Core	.032 Aramid Fiber	Very Good	.750	6	1200 / 550	5-6	25
	F20BS		.032 Stainless Steel		.750	6	1200 / 650	10-12	50
	F37BS	.375CP Single Core	.047 Stainless Steel	Good	1.375	6	800 / 450	25-30	125

BELT TENSIONER

TE-1

Material: Shaft 303 Stainless Steel
Housing Aluminum Black Anodized

Features: Easily adjusted by pivoting tensioner about mounting surface

Part Number: TE-1

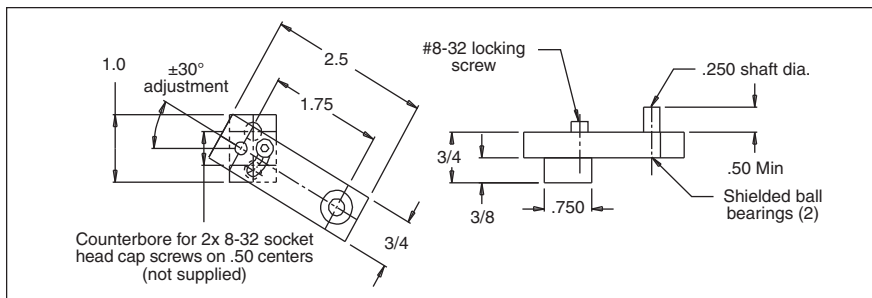

NO-SLIP SERIES

PIC's No-Slip and No-Slide High Performance Positioning Drive Systems

The No-Slip principle was introduced by PIC over 25 years ago. The No-Slip principle allows the drive system to function primarily as a precise positioning device by locating the drive pins on the belt pitch line, allowing them to mesh smoothly with the pulleys without the clearance required for standard belts and pulleys. The elimination of the clearance makes the drive system "backlash free" and an excellent means of maintaining the accuracy for precision positioning applications.

No-Slip belts utilize round drive pins which are molded perpendicularly to one or more molded tensile members. These molded tensile members are larger than the drive pins, which are located on the pitch line of the tensile member. The molded tensile member(s) surround a reinforcing cable(s) providing strength and minimal stretch while the loads are transferred through the tensile members to the pulley shoulders or grooves.

The 32DP (diametral pitch) No-Slip drive system is an industry standard. The single core belt runs on pulleys that are generated with precision involute form teeth. This fine pitch results in a greater number of teeth engaged, which produces the highest positioning accuracy for applications such as encoders and measuring devices. The involute form of the pulleys allows a spur gear to be driven by the belt or pulley. The 32DP twin core design No-Slip drive system offers additional strength for higher loads.

The .1475CP and .2500 CP No-Slip drive systems are twin core belts that are an economical solution to miniature pitch stainless steel chain. These belts are for high load carrying applications requiring No-Slip accuracy. These belts have replaced miniature pitch stainless steel chain in many existing applications.

The No-Slide principle allows the drive system to operate using pulleys without flanges. The belt stays on the center of the pulley due to an encapsulated stainless steel or Aramid cable in the center of the belt and a matching groove in the pulley.

The elimination of a flange results in two major benefits. It produces a more compact drive system and it also eliminates the air trapped by the flanges found on conventional synchronous belts — therefore making it a quieter running belt.

No-Slide belts are produced by a continuous polyurethane molding process with either a stainless steel or Aramid core. The finished belt is joined by crimping the cable ends within a stainless steel ferrule, which is then overmolded for added strength and protection of the pulley.

These polyurethane belts have inherent chemical and abrasion resistance that allow operation in applications where carbon dusting encountered with neoprene belts cannot be tolerated. The No-Slide series of belts are excellent for medical and packaging applications.

The design guide (shown on previous page) enables users to select the appropriate system for a particular application. The belt length calculations are included to insure that the proper belt length has been selected for the center distance and ratio of your drive system.

BELT LENGTH CALCULATIONS

D = Pitch Diameter Large Pulley (inches)
 d = Pitch Diameter Small Pulley (inches)
 C = Center Distance (inches)

α = Angle Between Belt and Centerline
 L = Belt Pitch Length (inches — approx.)

For Parallel Shafts:

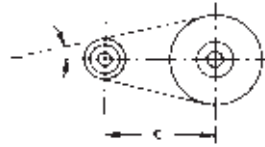

$$\alpha = \sin^{-1} \left[\frac{D-d}{2C} \right]$$

$$L = 2C \cos \alpha + \frac{\pi(D+d)}{2} + \frac{\pi\alpha(D-d)}{180}$$

or

$$L_{APPROX} = 2C + 1.57(D+d) + \frac{(D-d)^2}{4C}$$

For Right Angle Shafts FA & FS Only:

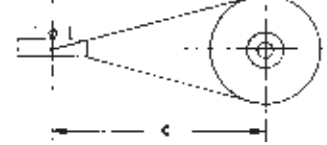

$$L = \frac{\pi}{2} (D + d) + \sqrt{4C^2 + D^2 + d^2}$$

BELT SPEED CALCULATIONS

$$BS (\text{fpm}) = (.262) \times PD \times \text{RPM}$$

CENTER DISTANCE CALCULATIONS

$$C = \frac{K + \sqrt{K^2 - 32(D-d)^2}}{16}$$

Where $K = 4L - 2\pi(D+d)$

STANDARD CALCULATIONS

Required	Given	Formula
Speed ratio (R)	Shaft speeds (rpm)	$R = \frac{\text{rpm (faster shaft speed)}}{\text{rpm (slower shaft speed)}}$
	Pulley Diameters (D & d)	$R = \frac{D \text{ (larger pulley diameter)}}{d \text{ (smaller pulley diameter)}}$
	Number of pulley grooves (N & n)	$R = \frac{N \text{ (larger pulley groove no.)}}{n \text{ (smaller pulley groove no.)}}$
Horsepower (hp)	Torque (T) in in.- lbs. Shaft speed (rpm)	$hp = \frac{T \times \text{rpm}}{63,025}$
Torque (T) in in.- lbs.	Shaft horsepower (hp) Shaft speed (rpm)	$T = \frac{63,025 \times \text{hp}}{\text{rpm}}$
Effective tension (Te)	Shaft horsepower (hp) Belt speed (BS)	$Te = \frac{33,000 \times \text{hp}}{BS}$
Effective tension (Te) in pounds	Torque (T) in in.- lbs. Pulley pd in inches	$Te = \frac{2 \times T}{pd}$

BELT SPLICING KIT

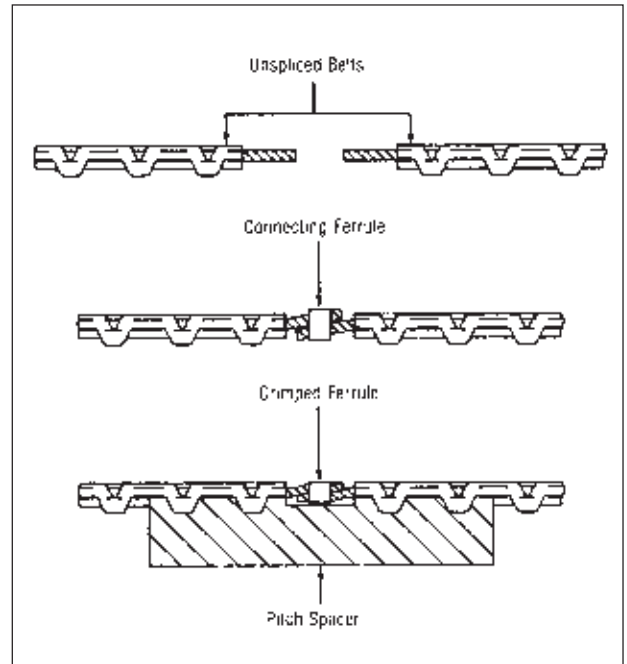

Belt splicing in the field is possible for NO-SLIP & NO-SLIDE positioning and timing belts when the appropriate splicing kit is used. Part numbers for these kits can be found on each No-Slip — No-Slide belt specification page or in the table below. In addition to containing a crimp tool & die set, positioning holddown rack and cable cutter; detailed procedures define the five basic steps to assure a correct splice. These steps are:

1. Cut belt to desired length
2. Remove polyurethane from each end
3. Insert ends into ferrule
4. Position belt into holddown feature
5. Crimp

When extra ferrules are required they may be ordered as follows:

Cable Size	Ferrule Part Number
.018" Diameter	FER018
.032" Diameter	FER032
.047" Diameter	FER047

Note: Because factory crimps use highly controlled pneumatic equipment and, in some cases polyurethane overmolding, field crimps result in loads that are 50% of the catalog ratings.

Field Belt Splicing Kit

Belt Series Number	Kit Part Number	Crimp Plier Part Number	Crimp Die Part Number	Hobby Knife Part Number	Stripper Cutter Part Number	Ferrules* Part Number	Position Rack & Hold Down Part Number	Flush** Cutter Part Number
FS / FA	F-SK	TL-91	TL-89	TL-86	TL-87	FER032	TL-70-71	—
FLS / FLA	FL-SK	TL-91	TL-89	TL-86	TL-87	FER032	TL-76-77	—
FMS / FMA	FM-SK	TL-91	TL-89	TL-86	TL-87	FER032	TL-78-79	—
FRS / FRA	FR-SK	TL-91	TL-89	TL-86	TL-87	FER032	TL-80-81	—
F8BS	F8B-SK	TL-91	TL-90	TL-86	TL-87	FER018	TL-62-63	—
F20BS / F20BA	F20B-SK	TL-91	TL-89	TL-86	TL-87	FER032	TL-60-61	TL-32
F20TS	F20T-SK	TL-91	TL-89	TL-86	TL-87	FER032	TL-66-67	—
F24CS / F24CA	F24C-SK	TL-91	TL-89	TL-86	TL-87	FER032	TL-72-73	—
F25CS	F25C-SK	TL-91	TL-89	TL-86	TL-87	FER032	TL-74-75	TL-32
F32BS18	F32B18-SK	TL-91	TL-90	TL-86	TL-87	FER018	TL-70-71	—
F32CS / F32CA	F32C-SK	TL-91	TL-90	TL-86	TL-87	FER018	TL-68-69	—
F37BS	F37B-SK	TL-91	TL-88	TL-86	TL-87	FER047	TL-64-65	TL-32

Notes:

- * Twenty (20) ferrules included in each kit.
- ** Heavy duty cutter supplied as indicated - can be ordered as option for other kits.

NO-SLIP POSITIVE DRIVE BELT - ULTRA PRECISION

32DP, .0982CP — Single Core

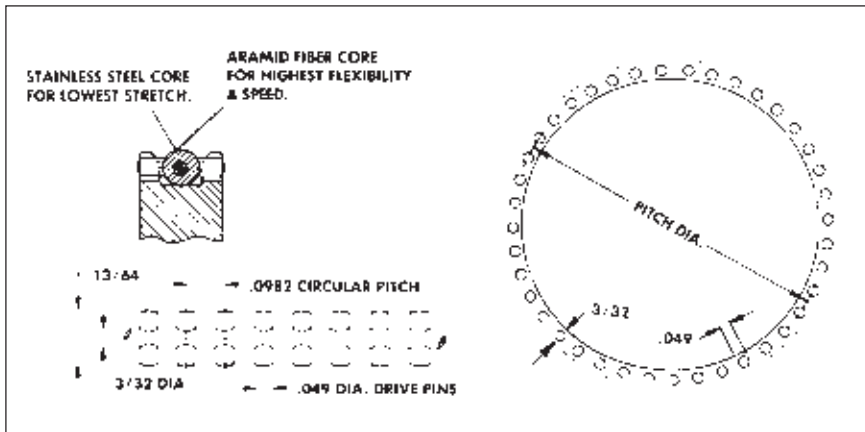
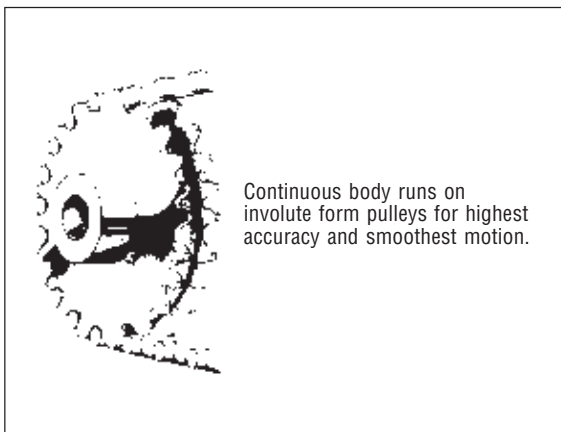

Material:

FA Series: Molded Polyurethane, .032" diameter Aramid Fiber Core (Kevlar). Color: Blue

FS Series: Molded Polyurethane, .032" diameter Stainless Steel Core. Color: Blue

Number of Drive Pins	Length (Ref.)	Part No. Aramid Core	Part No. Steel Core
64	6.283	FA-64	FS-64
80	7.854	FA-80	FS-80
95	9.327	FA-95	FS-95
112	10.996	FA-112	FS-112
126	12.370	FA-126	FS-126
128	12.566	FA-128	FS-128
144	14.137	FA-144	FS-144
158	15.512	FA-158	FS-158
176	17.279	FA-176	FS-176
189	18.557	FA-189	FS-189
208	20.420	FA-208	FS-208
220	21.598	FA-220	FS-220
240	23.562	FA-240	FS-240
252	24.740	FA-252	FS-252
272	26.704	FA-272	FS-272
283	27.784	FA-283	FS-283
304	29.845	FA-304	FS-304
315	30.923	FA-315	FS-315
336	32.987	FA-336	FS-336
346	33.967	FA-346	FS-346
368	36.128	FA-368	FS-368
377	37.011	FA-377	FS-377
400	39.270	FA-400	FS-400
408	40.055	FA-408	FS-408
432	42.412	FA-432	FS-432

Number of Drive Pins	Length (Ref.)	Part No. Aramid Core	Part No. Steel Core
440	43.197	FA-440	FS-440
464	45.553	FA-464	FS-464
471	46.238	FA-471	FS-471
480	47.124	FA-480	FS-480
496	48.695	FA-496	FS-496
512	50.265	FA-512	FS-512
528	51.836	FA-528	FS-528
544	53.407	FA-544	FS-544
560	54.978	FA-560	FS-560
576	56.549	FA-576	FS-576
592	58.120	FA-592	FS-592
608	59.690	FA-608	FS-608
624	61.261	FA-624	FS-624
640	62.832	FA-640	FS-640
656	64.402	FA-656	FS-656
672	65.973	FA-672	FS-672
688	67.544	FA-688	FS-688
704	69.115	FA-704	FS-704
720	70.686	FA-720	FS-720
736	72.257	FA-736	FS-736
752	73.827	FA-752	FS-752
768	75.398	FA-768	FS-768
784	76.969	FA-784	FS-784
800	78.540	FA-800	FS-800
—	—	—	—

Bulk Lengths — Not Spliced

Length	Aramid Core Part Number	Steel Core Part Number
5 Ft	FA-5FT	FS-5FT
10 Ft	FA-10FT	FS-10FT
25 Ft	FA-25FT	FS-25FT
50 Ft	FA-50FT	FS-50FT

For field splicing use Kit F-SK. See page 5-5.

For other length belts longer than the minimum listed, substitute the desired number of drive pins at the end of the part number.

32DP (.0982 CP) ORIGINAL SINGLE CORE NO-SLIP BELTS — SERIES FA & FS

Smoothest motion, highest accuracy. Continuous molded body runs on precision, involute form pulleys. Fine pitch results in greatest number of teeth engaged. Single core permits non-parallel or right angle shafts position. Recommended for highest accuracy, lower load applications such as encoders and measuring devices.

INCREASED FLEXIBILITY OPTION

For those applications requiring the greatest flexibility at a reduced load, PIC Design has this belt available with a .018" diameter stainless steel core. The part number is F32BS18-□□□. Where □□□ is the number of drive pins. Example: Part Number for 144 drive pins is F32BS18-144.

Bulk Lengths — Not Spliced

Length	Steel Core Part Number
5 Ft	F32BS18-5FT
10 Ft	F32BS18-10FT
25 Ft	F32BS18-25FT
50 Ft	F32BS18-50FT

For field splicing use Kit F-SK. See page 5-5.

NO-SLIP PULLEYS

32DP, .0982CP — For FA, FS & F32BS18 No-Slip Single Core Drive Belts

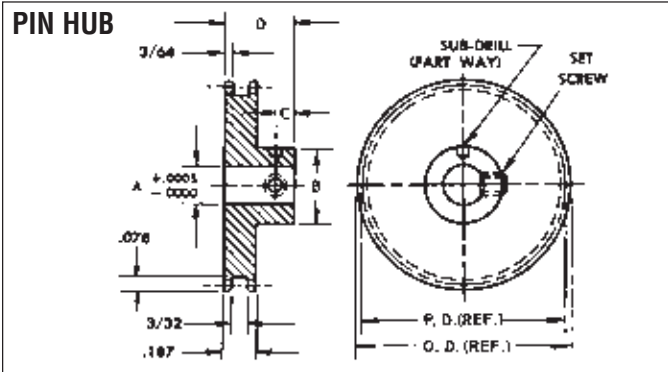

Dimen.	Bore				
	1/8	3/16	1/4	4 mm	6 mm
A	.1248	.1873	.2498	.1573	.2360
B	.312	.375	.500	.375	.500
C	.09	.11	.12	.11	.12
D	.375	.406	.437	.406	.437
Set Screw	#2-56	#4-40	#6-32	M2 x .4	M3 x .5

Material: 303 Stainless Steel
2024-T4 Aluminum (Anodized before cutting)

Geared Pulley Data			Stainless Steel Bore Size / Part Number					Aluminum Bore Size / Part Number				
No. Teeth	P.D.	O.D.	.1248	.1873	.2498	4mm	6mm	.1248	.1873	.2498	4mm	6mm
14 *	.4375	.500	FC1-14	—	—	—	—	FC2-14	—	—	—	—
15 *	.4687	.531	FC1-15	FC3-15	—	MGP1-15	—	FC2-15	FC4-15	—	MGP2-15	—
16	.5000	.563	FC1-16	FC3-16	—	MGP1-16	—	FC2-16	FC4-16	—	MGP2-16	—
18	.5625	.625	FC1-18	FC3-18	—	MGP1-18	—	FC2-18	FC4-18	—	MGP2-18	—
20	.6250	.688	FC1-20	FC3-20	FC5-20	MGP1-20	MGP3-20	FC2-20	FC4-20	FC6-20	MGP2-20	MGP4-20
22	.6875	.750	FC1-22	FC3-22	FC5-22	MGP1-22	MGP3-22	FC2-22	FC4-22	FC6-22	MGP2-22	MGP4-22
24	.7500	.813	FC1-24	FC3-24	FC5-24	MGP1-24	MGP3-24	FC2-24	FC4-24	FC6-24	MGP2-24	MGP4-24
26	.8125	.875	FC1-26	FC3-26	FC5-26	MGP1-26	MGP3-26	FC2-26	FC4-26	FC6-26	MGP2-26	MGP4-26
28	.8750	.938	FC1-28	FC3-28	FC5-28	MGP1-28	MGP3-28	FC2-28	FC4-28	FC6-28	MGP2-28	MGP4-28
30	.9375	1.000	FC1-30	FC3-30	FC5-30	MGP1-30	MGP3-30	FC2-30	FC4-30	FC6-30	MGP2-30	MGP4-30
32	1.0000	1.063	FC1-32	FC3-32	FC5-32	MGP1-32	MGP3-32	FC2-32	FC4-32	FC6-32	MGP2-32	MGP4-32
36	1.1250	1.188	FC1-36	FC3-36	FC5-36	MGP1-36	MGP3-36	FC2-36	FC4-36	FC6-36	MGP2-36	MGP4-36
40	1.2500	1.313	FC1-40	FC3-40	FC5-40	MGP1-40	MGP3-40	FC2-40	FC4-40	FC6-40	MGP2-40	MGP4-40
48	1.5000	1.563	FC1-48	FC3-48	FC5-48	MGP1-48	MGP3-48	FC2-48	FC4-48	FC6-48	MGP2-48	MGP4-48
56	1.7500	1.813	FC1-56	FC3-56	FC5-56	MGP1-56	MGP3-56	FC2-56	FC4-56	FC6-56	MGP2-56	MGP4-56
64	2.0000	2.063	FC1-64	FC3-64	FC5-64	MGP1-64	MGP3-64	FC2-64	FC4-64	FC6-64	MGP2-64	MGP4-64
72	2.2500	2.313	FC1-72	FC3-72	FC5-72	MGP1-72	MGP3-72	FC2-72	FC4-72	FC6-72	MGP2-72	MGP4-72
80	2.5000	2.563	—	FC3-80	FC5-80	MGP1-80	MGP3-80	—	FC4-80	FC6-80	MGP2-80	MGP4-80
88	2.7500	2.813	—	FC3-88	FC5-88	MGP1-88	MGP3-88	—	FC4-88	FC6-88	MGP2-88	MGP4-88
96	3.0000	3.063	—	FC3-96	FC5-96	MGP1-96	MGP3-96	—	FC4-96	FC6-96	MGP2-96	MGP4-96
112	3.5000	3.563	—	FC3-112	FC5-112	MGP1-112	MGP3-112	—	FC4-112	FC6-112	MGP2-112	MGP4-112
128	4.0000	4.063	—	FC3-128	FC5-128	MGP1-128	MGP3-128	—	FC4-128	FC6-128	MGP2-128	MGP4-128

* Recommended for use as an idler only

See Note Below.

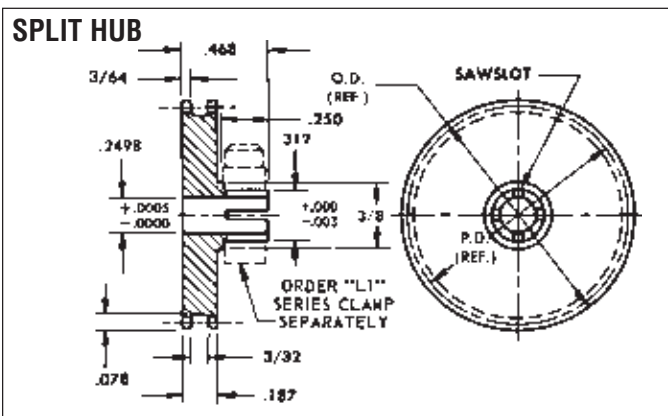

Note:

Other Size Bores Available, Consult Factory.
For unlisted number of teeth, specify the number of teeth desired as the last figure in the part number.
EXAMPLE: For a 52-tooth stainless steel pulley, specify Part Number: FD5-52.
For number of teeth above or below listed sizes, consult factory.

Pully Data			Stainless Steel .2498 Bore Part No.	Aluminum .2498 Bore Part No.
No. Teeth	P.D.	O.D.		
14 *	.4375	.500	FD5-14	FD6-14
15 *	.4687	.531	FD5-15	FD6-15
16	.5000	.563	FD5-16	FD6-16
18	.5625	.625	FD5-18	FD6-18
20	.6250	.688	FD5-20	FD6-20
22	.6875	.750	FD5-22	FD6-22
24	.7500	.813	FD5-24	FD6-24
26	.8125	.875	FD5-26	FD6-26
28	.8750	.938	FD5-28	FD6-28
30	.9375	1.000	FD5-30	FD6-30
32	1.0000	1.063	FD5-32	FD6-32
36	1.1250	1.188	FD5-36	FD6-36
40	1.2500	1.313	FD5-40	FD6-40
48	1.5000	1.563	FD5-48	FD6-48
56	1.7500	1.813	FD5-56	FD6-56
64	2.0000	2.063	FD5-64	FD6-64
72	2.2500	2.313	FD5-72	FD6-72

* Recommended for use as an idler only

NO-SLIP POSITIVE DRIVE BELT

32DP, .0982 CP — Twin Core

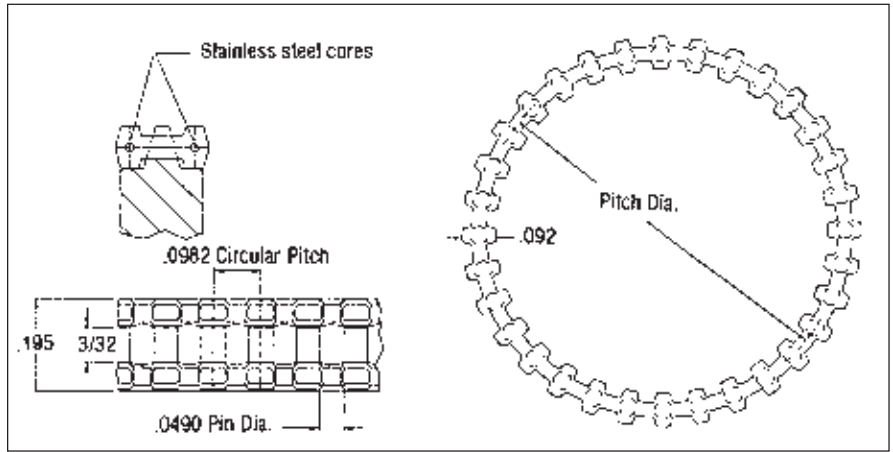
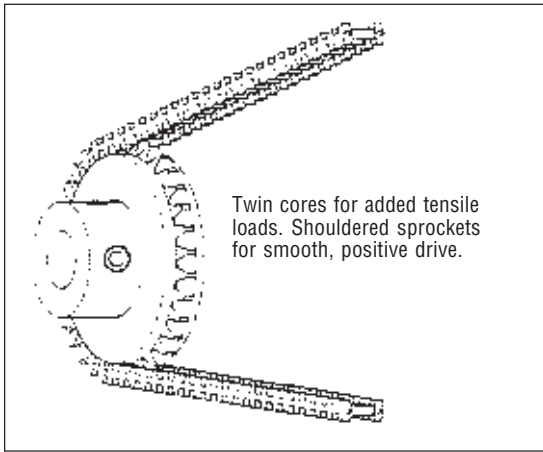

Material: F32CS Series: Molded Polyurethane, .018" diameter Stainless Steel Cores.

Color: Blue

Number of Drive Pins	Length (Ref.)	Part No.	Number of Drive Pins	Length (Ref.)	Part No.
42	4.124	F32CS-42	252	24.746	F32CS-252
49	4.812	F32CS-49	272	26.710	F32CS-272
52	5.106	F32CS-52	283	27.791	F32CS-283
53	5.205	F32CS-53	304	29.853	F32CS-304
64	6.285	F32CS-64	315	30.933	F32CS-315
67	6.579	F32CS-67	336	32.955	F32CS-336
75	7.365	F32CS-75	346	33.977	F32CS-346
80	7.856	F32CS-80	377	37.021	F32CS-377
95	9.329	F32CS-95	400	39.280	F32CS-400
112	10.998	F32CS-112	408	40.066	F32CS-408
126	12.373	F32CS-126	432	42.422	F32CS-432
128	12.570	F32CS-128	440	43.208	F32CS-440
144	14.141	F32CS-144	464	45.565	F32CS-464
158	15.516	F32CS-158	471	46.252	F32CS-471
176	17.283	F32CS-176	480	47.136	F32CS-480
189	18.560	F32CS-189	512	50.278	F32CS-512
208	20.426	F32CS-208	544	53.421	F32CS-544
220	21.604	F32CS-220	592	58.134	F32CS-592
240	23.568	F32CS-240	608	59.706	F32CS-608

For other length belts longer than the minimum listed, substitute the desired number of drive pins at the end of the part number.

Bulk Lengths — Not Spliced

Length	Part Number
5 Ft	F32CS-5FT
10 Ft	F32CS-10FT
25 Ft	F32CS-25FT
50 Ft	F32CS-50FT
100 Ft	F32CS-100FT

For field splicing use Kit F32C-SK. See page 5-5.

32DP (.0982 CP) TWIN CORE NO-SLIP BELTS — SERIES F32CS

Smoothest motion, highest accuracy. This belt runs on precision sprockets. Fine pitch results in greatest number of teeth engaged. Twin core offers added strength for higher loads.

NO-SLIP SPROCKETS

32DP, .0982CP — For F32 No-Slip Drive Belts

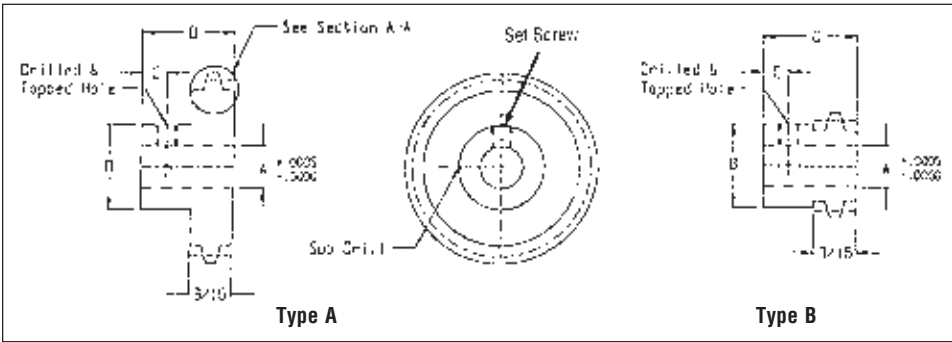

Dimen.	Bore Size				
	1/8"	3/16"	1/4"	4 mm	6 mm
A	.1248	.1873	.2498	.1573	.2360
B	.312	.375	.500	.375	.500
C	.09	.11	.12	.11	.12
D	.375	.406	.437	.406	.437
Set Screw	#2-56	#4-40	#6-32	M2X.4	M3X.5

Material: 303 Stainless Steel
2024-T4 Aluminum
(Anodized Before Cutting)

Hub Style

Type	No. of Teeth	Pitch Dia.	Outside Dia.	Stainless Steel Part No.			Aluminum Part No.		
				.1248	.1873	.2498	.1248	.1873	.2498
B	12 *	.3750	.437	F32G1-12	—	—	F32G2-12	—	—
B	13 *	.4062	.468	F32G1-13	F32G3-13	—	F32G2-13	F32G4-13	—
B	14 *	.4375	.500	F32G1-14	F32G3-14	F32G5-14**	F32G2-14	F32G4-14	F32G6-14**
A	15 *	.4687	.531	F32G1-15	F32G3-15	F32G5-15**	F32G2-15	F32G4-15	F32G6-15**
A	16 *	.5000	.562	F32G1-16	F32G3-16	F32G5-16**	F32G2-16	F32G4-16	F32G6-16**
A	18	.5625	.625	F32G1-18	F32G3-18	F32G5-18**	F32G2-18	F32G4-18	F32G6-18**
A	20	.6250	.687	F32G1-20	F32G3-20	F32G5-20	F32G2-20	F32G4-20	F32G6-20
A	22	.6875	.750	F32G1-22	F32G3-22	F32G5-22	F32G2-22	F32G4-22	F32G6-22
A	24	.7500	.812	F32G1-24	F32G3-24	F32G5-24	F32G2-24	F32G4-24	F32G6-24
A	26	.8125	.875	F32G1-26	F32G3-26	F32G5-26	F32G2-26	F32G4-26	F32G6-26
A	28	.8750	.937	F32G1-28	F32G3-28	F32G5-28	F32G2-28	F32G4-28	F32G6-28
A	30	.9375	1.000	F32G1-30	F32G3-30	F32G5-30	F32G2-30	F32G4-30	F32G6-30
A	32	1.0000	1.062	F32G1-32	F32G3-32	F32G5-32	F32G2-32	F32G4-32	F32G6-32
A	36	1.1250	1.187	F32G1-36	F32G3-36	F32G5-36	F32G2-36	F32G4-36	F32G6-36
A	40	1.2500	1.312	F32G1-40	F32G3-40	F32G5-40	F32G2-40	F32G4-40	F32G6-40
A	48	1.5000	1.562	F32G1-48	F32G3-48	F32G5-48	F32G2-48	F32G4-48	F32G6-48
A	56	1.7500	1.812	F32G1-56	F32G3-56	F32G5-56	F32G2-56	F32G4-56	F32G6-56
A	64	2.0000	2.062	F32G1-64	F32G3-64	F32G5-64	F32G2-64	F32G4-64	F32G6-64
A	72	2.2500	2.312	F32G1-72	F32G3-72	F32G5-72	F32G2-72	F32G4-72	F32G6-72
A	80	2.5000	2.562	F32G1-80	F32G3-80	F32G5-80	F32G2-80	F32G4-80	F32G6-80
A	88	2.7500	2.812	F32G1-88	F32G3-88	F32G5-88	F32G2-88	F32G4-88	F32G6-88
A	96	3.0000	3.062	F32G1-96	F32G3-96	F32G5-96	F32G2-96	F32G4-96	F32G6-96
A	112	3.5000	3.562	F32G1-112	F32G3-112	F32G5-112	F32G2-112	F32G4-112	F32G6-112
A	128	4.0000	4.062	F32G1-128	F32G3-128	F32G5-128	F32G2-128	F32G4-128	F32G6-128

* Recommended for use as an idler only
** Type "B" Sprocket Style

See Note Below.

For Metric Bores:

Bore	Stainless Steel	Aluminum
4 mm	MF32G1-XX	MF32G2-XX
6 mm	MF32G3-XX	MF32G4-XX

XX = Number of grooves

Hubless Style

No of Teeth	Pitch Dia.	Outside Dia.	Stainless Steel Part No.	Aluminum Part No.
32	1.0000	1.062	F32J1-32	F32J2-32
36	1.1250	1.187	F32J1-36	F32J2-36
40	1.2500	1.312	F32J1-40	F32J2-40
48	1.5000	1.562	F32J1-48	F32J2-48
50	1.5625	1.625	F32J1-50	F32J2-50
56	1.7500	1.812	F32J1-56	F32J2-56
64	2.0000	2.062	F32J1-64	F32J2-64
72	2.2500	2.312	F32J1-72	F32J2-72
80	2.5000	2.562	F32J1-80	F32J2-80
88	2.7500	2.812	F32J1-88	F32J2-88
90	2.8125	2.875	F32J1-90	F32J2-90
96	3.0000	3.062	F32J1-96	F32J2-96
100	3.1250	3.187	F32J1-100	F32J2-100
112	3.5000	3.562	F32J1-112	F32J2-112
120	3.7500	3.812	F32J1-120	F32J2-120
128	4.0000	4.062	F32J1-128	F32J2-128

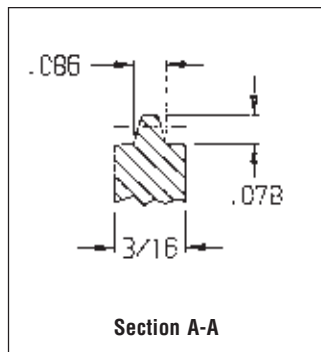
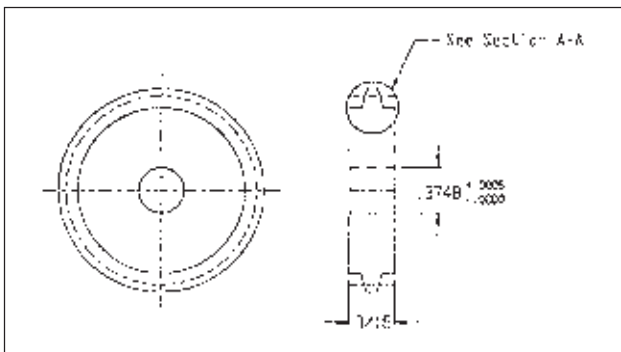

Note:

Other Size Bores Available, Consult Factory.
For unlisted number of teeth, specify the number of teeth desired as the last figure in the part number.
EXAMPLE: For a 52-tooth stainless steel sprocket, specify Part Number: F32G5-52.
For number of teeth above or below listed sizes, consult factory.

NO-SLIP POSITIVE DRIVE BELT

24 DP .1309 CP Twin Core

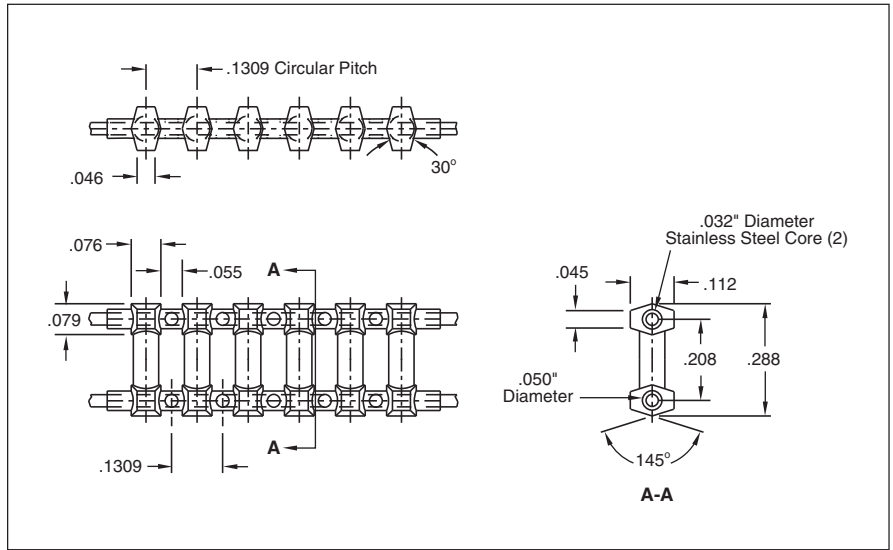
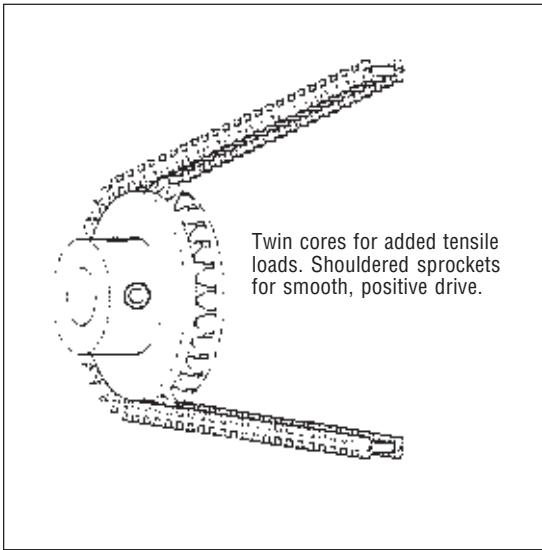

Material: F24CS-Series: Molded Polyurethane, .032" diameter Stainless Steel Cores. Color Red
 F24CA-Series: Molded Polyurethane, .032" diameter Aramid Fiber (Kevlar) Cores. Color Red

Number Of Drive Pins	Length (Ref.)	Part Number*	Number Of Drive Pins	Length (Ref.)	Part Number*
50	6.545	F24CS-50	120	15.708	F24CS-120
52	6.807	F24CS-52	130	17.017	F24CS-130
54	7.069	F24CS-54	140	18.326	F24CS-140
56	7.330	F24CS-56	150	19.635	F24CS-150
58	7.592	F24CS-58	160	20.944	F24CS-160
60	7.854	F24CS-60	170	22.253	F24CS-170
62	8.116	F24CS-62	180	23.562	F24CS-180
64	8.378	F24CS-64	190	24.871	F24CS-190
66	8.639	F24CS-66	200	26.180	F24CS-200
68	8.901	F24CS-68	220	28.798	F24CS-220
70	9.163	F24CS-70	240	31.416	F24CS-240
75	9.818	F24CS-75	260	34.034	F24CS-260
80	10.472	F24CS-80	280	36.652	F24CS-280
85	11.127	F24CS-85	300	39.270	F24CS-300
90	11.781	F24CS-90	320	41.888	F24CS-320
95	12.436	F24CS-95	340	44.506	F24CS-340
100	13.090	F24CS-100	360	47.124	F24CS-360
105	13.745	F24CS-105	380	49.742	F24CS-380
110	14.399	F24CS-110	400	52.360	F24CS-400
115	15.054	F24CS-115	420	54.978	F24CS-420

* For Aramid Cores, substitute A for S in the part number
 For other length belts longer than the minimum listed, substitute the desired number of drive pins at the end of the part number.

Bulk Footage — Not Spliced

Length	Part Number*
5 Ft	F24CS-5FT
10 Ft	F24CS-10FT
25 Ft	F24CS-25FT
50 Ft	F24CS-50FT
100 Ft	F24CS-100FT

Special length belts and other bulk lengths available. Consult factory.

For field splicing use Kit F24C-SK.
 See page 5-5.

* For Aramid Cores, substitute A for S in the part number

24 DP (.1309CP) Twin Core No-Slip Belts — Series F24CS

Smooth motion, excellent accuracy. Use F24G and MF24G sprockets.
 Operates with 24-pitch spur gears.

NO-SLIP SPROCKETS

24 DP, .1309 CP-1/4, 3/8, 1/2 — 8 mm, 10 mm & 12 mm Bores for No-Slip, Twin Core Drive Belts

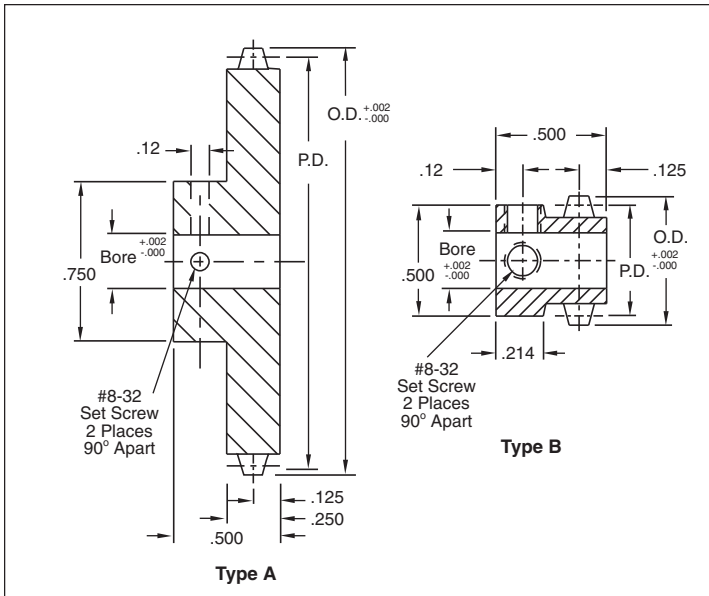

Number Of Teeth	Type	P.D. (Inches)	O.D. (Inches)	Bore Size / Part Number		
				.250	.375	.500
12 *	B	.4994	.582	F24G4-12	—	—
14 *	B	.5827	.665	F24G4-14	—	—
15 *	B	.6243	.707	F24G4-15	F24G6-15	—
16 *	A	.6659	.749	F24G4-16	F24G6-16	F24G8-16
18 *	A	.7492	.832	F24G4-18	F24G6-18	F24G8-18
20	A	.8324	.915	F24G4-20	F24G6-20	F24G8-20
21	A	.8740	.957	F24G4-21	F24G6-21	F24G8-21
24	A	.9989	1.082	F24G4-24	F24G6-24	F24G8-24
30	A	1.2486	1.331	F24G4-30	F24G6-30	F24G8-30
36	A	1.4983	1.581	F24G4-36	F24G6-36	F24G8-36
42	A	1.7480	1.831	F24G4-42	F24G6-42	F24G8-42
48	A	1.9978	2.081	F24G4-48	F24G6-48	F24G8-48
60	A	2.4972	2.580	F24G4-60	F24G6-60	F24G8-60
72	A	2.9966	3.079	F24G4-72	F24G6-72	F24G8-72
96	A	3.9955	4.078	F24G4-96	F24G6-96	F24G8-96
120	A	4.9944	5.077	F24G4-120	F24G6-120	F24G8-120
144	A	5.9933	6.076	F24G4-144	F24G6-144	F24G8-144

* Recommended for use as an idler only

See Note Below.

Material: 2024-T4 Aluminum (anodized before cutting)

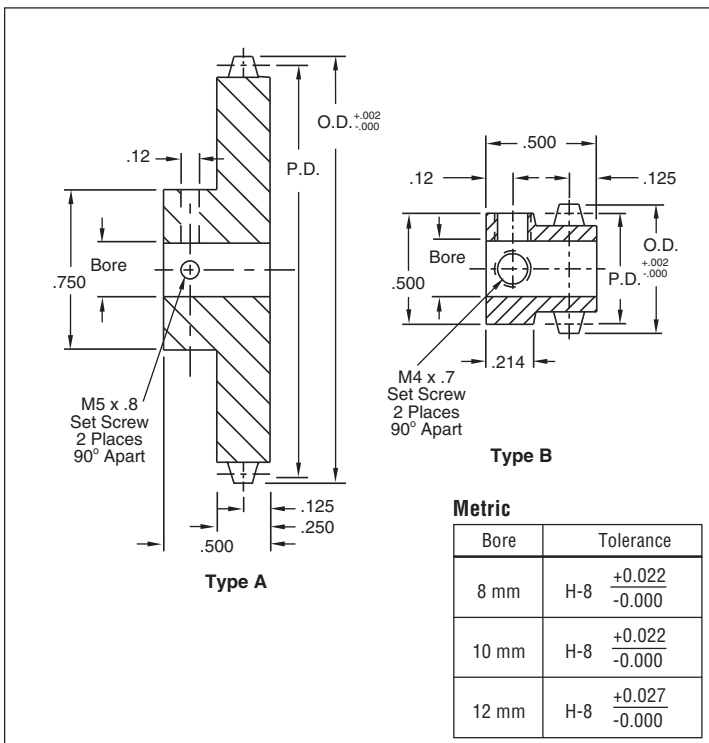

Number Of Teeth	Type	P.D. (Inches)	O.D. (Inches)	Bore Size / Part Number (Metric)		
				8 mm	10 mm	12 mm
12 *	B	.4994	.582	MF24G8-12	—	—
14 *	B	.5827	.665	MF24G8-14	—	—
15 *	B	.6243	.707	MF24G8-15	MF24G10-15	—
16 *	A	.6659	.749	MF24G8-16	MF24G10-16	MF24G12-16
18 *	A	.7492	.832	MF24G8-18	MF24G10-18	MF24G12-18
20	A	.8324	.915	MF24G8-20	MF24G10-20	MF24G12-20
21	A	.8740	.957	MF24G8-21	MF24G10-21	MF24G12-21
24	A	.9989	1.082	MF24G8-24	MF24G10-24	MF24G12-24
30	A	1.2486	1.331	MF24G8-30	MF24G10-30	MF24G12-30
36	A	1.4983	1.581	MF24G8-36	MF24G10-36	MF24G12-36
42	A	1.7480	1.831	MF24G8-42	MF24G10-42	MF24G12-42
48	A	1.9978	2.081	MF24G8-48	MF24G10-48	MF24G12-48
60	A	2.4972	2.580	MF24G8-60	MF24G10-60	MF24G12-60
72	A	2.9966	3.079	MF24G8-72	MF24G10-72	MF24G12-72
96	A	3.9955	4.078	MF24G8-96	MF24G10-96	MF24G12-96
120	A	4.9944	5.077	MF24G8-120	MF24G10-120	MF24G12-120
144	A	5.9933	6.076	MF24G8-144	MF24G10-144	MF24G12-144

* Recommended for use as an idler only

Metric	
Bore	Tolerance
8 mm	H-8 $\frac{+0.022}{-0.000}$
10 mm	H-8 $\frac{+0.022}{-0.000}$
12 mm	H-8 $\frac{+0.027}{-0.000}$

Material: 2024-T4 Aluminum (anodized before cutting)

Note:

Other Size Bores Available, Consult Factory.
For unlisted number of teeth, specify the number of teeth desired as the last digits in the part number.

EXAMPLE: For a 52-tooth 1/4" bore sprocket, specify Part Number: F24G4-52
For number of teeth above or below listed sizes, consult factory.

NO-SLIP POSITIVE DRIVE BELT

.1475CP, Twin Core Economical High Performance Miniature Steel Chain Replacement

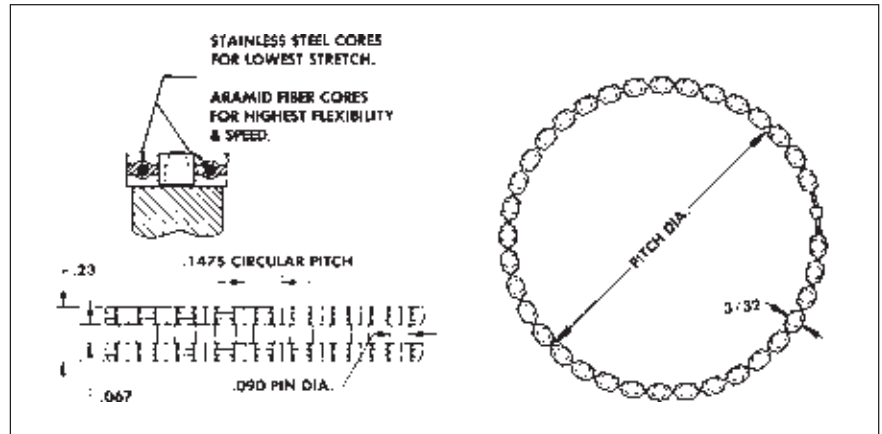

Material:

FRA - Series: Molded Polyurethane, .032" diameter Aramid Fiber Cores. Color: Clear

FRS - Series: Molded Polyurethane, .032" diameter Stainless Steel Cores. Color: Clear

Number of Drive Pins	Length (Ref.)	Part No. Aramid Core	Part No. Steel Core
40	5.900	FRA-040	FRS-040
50	7.375	FRA-050	FRS-050
60	8.850	FRA-060	FRS-060
70	10.325	FRA-070	FRS-070
80	11.800	FRA-080	FRS-080
90	13.275	FRA-090	FRS-090
100	14.750	FRA-100	FRS-100
110	16.225	FRA-110	FRS-110
120	17.700	FRA-120	FRS-120
130	19.175	FRA-130	FRS-130
140	20.650	FRA-140	FRS-140
150	22.125	FRA-150	FRS-150
160	23.600	FRA-160	FRS-160
170	25.075	FRA-170	FRS-170
180	26.550	FRA-180	FRS-180
190	28.025	FRA-190	FRS-190
200	29.500	FRA-200	FRS-200
210	30.975	FRA-210	FRS-210

Number of Drive Pins	Length (Ref.)	Part No. Aramid Core	Part No. Steel Core
220	32.450	FRA-220	FRS-220
230	33.925	FRA-230	FRS-230
240	35.400	FRA-240	FRS-240
250	36.825	FRA-250	FRS-250
260	38.350	FRA-260	FRS-260
270	39.825	FRA-270	FRS-270
280	41.300	FRA-280	FRS-280
290	42.775	FRA-290	FRS-290
300	44.250	FRA-300	FRS-300
310	45.725	FRA-310	FRS-310
320	47.200	FRA-320	FRS-320
330	48.675	FRA-330	FRS-330
340	50.150	FRA-340	FRS-340
350	51.625	FRA-350	FRS-350
360	53.100	FRA-360	FRS-360
370	54.575	FRA-370	FRS-370
380	56.050	FRA-380	FRS-380
390	57.525	FRA-390	FRS-390

Bulk Lengths — Not Spliced

Length	Aramid Core Part Number	Steel Core Part Number
5 Ft	FRA-5FT	FRS-5FT
10 Ft	FRA-10FT	FRS-10FT
25 Ft	FRA-25FT	FRS-25FT
50 Ft	FRA-50FT	FRS-50FT
100 Ft	FRA-100FT	FRS-100FT

For field splicing use Kit FR-SK.
See page 5-5.

For other length belts longer than the minimum listed, substitute the desired number of drive pins at the end of the part number.

.1475 CP TWIN CORE NO-SLIP BELTS. SERIES FRA & FRS

The workhorse of the No-Slip line. Designed to provide an economical alternative to miniature pitch stainless steel chain. Smoother motion than possible with chain. FRA & FRS belts operate without the chordal rise and fall (camming effect) of chain. Will not continually grow in length as chain does. Drive pins are 30% larger in diameter than the FM series for additional strength. Recommended as a cost saving alternative to chain and for the highest load belt applications requiring No-Slip accuracy. Will replace miniature pitch steel chain in many existing applications.

NO-SLIP SPROCKETS

.1475CP, 1/8, 3/16, 1/4, Bores For FRA & FRS No-Slip, Twin Core Drive Belts

PIN HUB

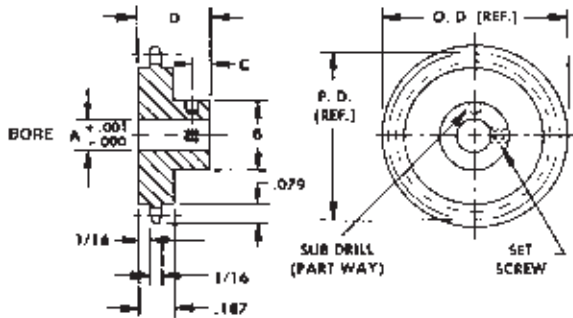

Material: 303 Stainless Steel
2024-T4 Aluminum
(Anodized Before Cutting)

Dimen.	Bore Size				
	1/8"	3/16"	1/4"	4 mm	6 mm
A	.1248	.1873	.2498	.1573	.2360
B	.312	.375	.500	.375	.500
C	.09	.11	.12	.11	.12
D	.375	.406	.437	.406	.437
Set Screw	#2-56	#4-40	#6-32	M2X.4	M3X.5

For Metric Bores:

Bore	Stainless Steel	Aluminum
4 mm	MFRG1-XX	MFRG2-XX
6 mm	MFRG3-XX	MFRG4-XX

XX = Number of grooves

Sprocket Data			Stainless Steel Bore Size Part Number			Aluminum Bore Size Part Number		
No. Teeth	P.D.	O.D.	.1248	.1873	.2498	.1248	.1873	.2498
10*	.477	.529	FRG1-010	FRG3-010	—	FRG2-010	FRG4-010	—
11*	.524	.579	FRG1-011	FRG3-011	—	FRG2-011	FRG4-011	—
12*	.570	.622	FRG1-012	FRG3-012	—	FRG2-012	FRG4-012	—
13*	.616	.668	FRG1-013	FRG3-013	FRG5-013	FRG2-013	FRG4-013	FRG6-013
14*	.663	.715	FRG1-014	FRG3-014	FRG5-014	FRG2-014	FRG4-014	FRG6-014
15*	.709	.761	FRG1-015	FRG3-015	FRG5-015	FRG2-015	FRG4-015	FRG6-015
16	.756	.808	FRG1-016	FRG3-016	FRG5-016	FRG2-016	FRG4-016	FRG6-016
17	.803	.855	FRG1-017	FRG3-017	FRG5-017	FRG2-017	FRG4-017	FRG6-017
18	.849	.901	FRG1-018	FRG3-018	FRG5-018	FRG2-018	FRG4-018	FRG6-018
19	.896	.948	FRG1-019	FRG3-019	FRG5-019	FRG2-019	FRG4-019	FRG6-019
20	.943	.995	FRG1-020	FRG3-020	FRG5-020	FRG2-020	FRG4-020	FRG6-020
22	1.036	1.088	FRG1-022	FRG3-022	FRG5-022	FRG2-022	FRG4-022	FRG6-022
24	1.130	1.182	FRG1-024	FRG3-024	FRG5-024	FRG2-024	FRG4-024	FRG6-024
25	1.177	1.228	FRG1-025	FRG3-025	FRG5-025	FRG2-025	FRG4-025	FRG6-025
26	1.224	1.276	FRG1-026	FRG3-026	FRG5-026	FRG2-026	FRG4-026	FRG6-026
28	1.317	1.369	FRG1-028	FRG3-028	FRG5-028	FRG2-028	FRG4-028	FRG6-028
30	1.411	1.463	FRG1-030	FRG3-030	FRG5-030	FRG2-030	FRG4-030	FRG6-030
32	1.505	1.557	FRG1-032	FRG3-032	FRG5-032	FRG2-032	FRG4-032	FRG6-032
35	1.645	1.697	FRG1-035	FRG3-035	FRG5-035	FRG2-035	FRG4-035	FRG6-035
36	1.692	1.744	FRG1-036	FRG3-036	FRG5-036	FRG2-036	FRG4-036	FRG6-036
40	1.880	1.932	FRG1-040	FRG3-040	FRG5-040	FRG2-040	FRG4-040	FRG6-040
45	2.114	2.166	FRG1-045	FRG3-045	FRG5-045	FRG2-045	FRG4-045	FRG6-045
48	2.255	2.307	FRG1-048	FRG3-048	FRG5-048	FRG2-048	FRG4-048	FRG6-048
50	2.349	2.401	—	FRG3-050	FRG5-050	—	FRG4-050	FRG6-050
55	2.584	2.636	—	FRG3-055	FRG5-055	—	FRG4-055	FRG6-055
60	2.818	2.870	—	FRG3-060	FRG5-060	—	FRG4-060	FRG6-060
65	3.053	3.105	—	FRG3-065	FRG5-065	—	FRG4-065	FRG6-065
85	3.992	4.044	—	FRG3-085	FRG5-085	—	FRG4-085	FRG6-085

* Recommended for use as an idler only

See Note Below.

SPLIT HUB

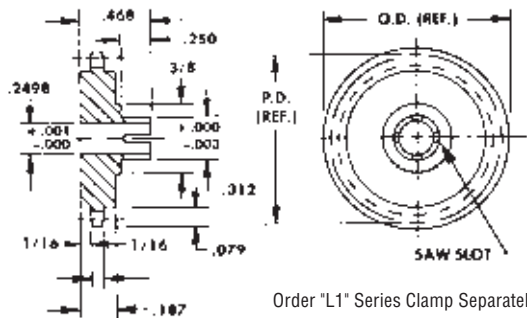

Note:

Other Size Bores Available, Consult Factory.
For unlisted number of teeth, specify the number of teeth desired as the last digits in the part number.
EXAMPLE: For a 52-tooth stainless steel sprocket, specify Part Number: FRH5-052
For number of teeth above or below listed sizes, consult factory.

Sprocket Data			Stainless Steel Part Number	Aluminum Part Number
No. Teeth	P.D.	O.D.	.2498 Bore Size	.2498 Bore Size
13*	.616	.668	FRH5-013	FRH6-013
14*	.663	.715	FRH5-014	FRH6-014
15*	.709	.761	FRH5-015	FRH6-015
16	.756	.808	FRH5-016	FRH6-016
17	.803	.855	FRH5-017	FRH6-017
18	.849	.901	FRH5-018	FRH6-018
19	.896	.948	FRH5-019	FRH6-019
20	.943	.995	FRH5-020	FRH6-020
22	1.036	1.088	FRH5-022	FRH6-022
24	1.130	1.182	FRH5-024	FRH6-024
25	1.177	1.228	FRH5-025	FRH6-025
26	1.224	1.276	FRH5-026	FRH6-026
28	1.317	1.369	FRH5-028	FRH6-028
30	1.411	1.463	FRH5-030	FRH6-030
32	1.505	1.557	FRH5-032	FRH6-032
35	1.645	1.697	FRH5-035	FRH6-035
36	1.692	1.744	FRH5-036	FRH6-036
40	1.880	1.932	FRH5-040	FRH6-040
45	2.114	2.166	FRH5-045	FRH6-045
48	2.255	2.307	FRH5-048	FRH6-048

* Recommended for use as an idler only

NO-SLIP POSITIVE DRIVE BELT

20DP, .15708CP Single Core and Triple Core

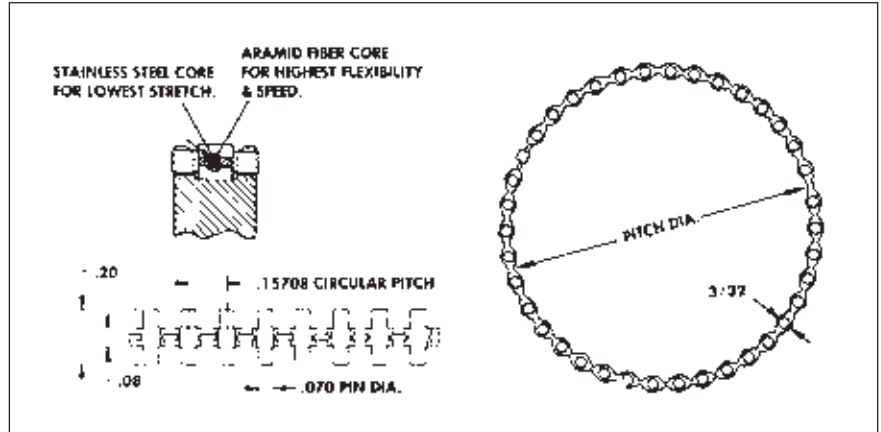
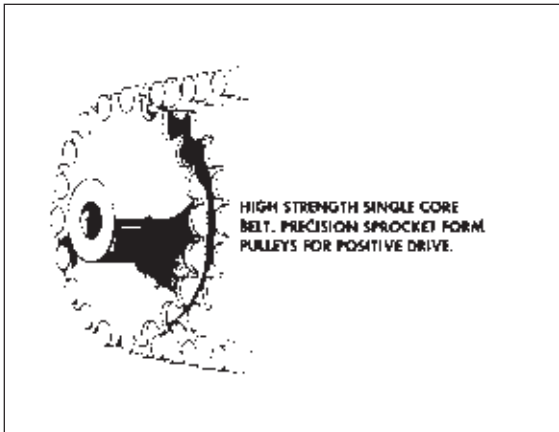

Material:

FLA-Series: Molded Polyurethane, .032" diameter Aramid Fiber Kevlar Core.

Color: Clear

FLS-Series: Molded Polyurethane, .032" diameter Stainless Steel Core.

Color: Clear

Number of Drive Pins	Length (Ref.)	Part No. Aramid Core	Part No. Steel Core
30	4.712	FLA-030	FLS-030
35	5.498	FLA-035	FLS-035
40	6.283	FLA-040	FLS-040
45	7.068	FLA-045	FLS-045
50	7.854	FLA-050	FLS-050
55	8.639	FLA-055	FLS-055
60	9.424	FLA-060	FLS-060
70	10.995	FLA-070	FLS-070
80	12.566	FLA-080	FLS-080
90	14.137	FLA-090	FLS-090
100	15.708	FLA-100	FLS-100
110	17.278	FLA-110	FLS-110
120	18.849	FLA-120	FLS-120
130	20.420	FLA-130	FLS-130
140	21.991	FLA-140	FLS-140
150	23.562	FLA-150	FLS-150
160	25.132	FLA-160	FLS-160
170	26.703	FLA-170	FLS-170
180	28.274	FLA-180	FLS-180
190	29.845	FLA-190	FLS-190
200	31.416	FLA-200	FLS-200

Number of Drive Pins	Length (Ref.)	Part No. Aramid Core	Part No. Steel Core
210	32.986	FLA-210	FLS-210
220	34.557	FLA-220	FLS-220
230	36.128	FLA-230	FLS-230
240	37.699	FLA-240	FLS-240
250	39.270	FLA-250	FLS-250
260	40.840	FLA-260	FLS-260
270	42.411	FLA-270	FLS-270
280	43.982	FLA-280	FLS-280
290	45.553	FLA-290	FLS-290
300	47.124	FLA-300	FLS-300
310	48.694	FLA-310	FLS-310
320	50.265	FLA-320	FLS-320
330	51.836	FLA-330	FLS-330
340	53.407	FLA-340	FLS-340
350	54.978	FLA-350	FLS-350
360	56.548	FLA-360	FLS-360
370	58.119	FLA-370	FLS-370
380	59.690	FLA-380	FLS-380
400	62.832	FLA-400	FLS-400
420	65.973	FLA-420	FLS-420
440	69.115	FLA-440	FLS-440

For other length belts longer than the minimum listed, substitute the desired number of drive pins at the end of the part number.

Bulk Lengths — Not Spliced

Length	Single Core		Triple Core
	Aramid Core Part Number	Steel Core Part Number	Steel Core Part Number
5 Ft	FLA-5FT	FLS-5FT	F20TS-5FT
10 Ft	FLA-10FT	FLS-10FT	F20TS-10FT
25 Ft	FLA-25FT	FLS-25FT	F20TS-25FT
50 Ft	FLA-50FT	FLS-50FT	F20TS-50FT
100 Ft	FLA-100FT	FLS-100FT	F20TS-100FT

For field splicing use Kit FL-SK. See page 5-5.

20DP (.15708 CP) SINGLE CORE NO-SLIP BELTS, SERIES FLA & FLS

High strength, hi-flex version of the 32DP NO-SLIP belt. Drive pins have 50% larger diameter than the 32DP series. The belt body is relieved between the pins providing ultimate flexibility over small pulleys. The continuous body web is designed to flex laterally to permit shaft misalignment and turning of corners. Run on precision sprocket form pulleys for positive power. Recommended for higher load, speed, and flex applications requiring a single core belt.

Triple Core Belts

Material:

F20TS-Series: Molded Polyurethane, Stainless Steel Core.

Color: Light Brown

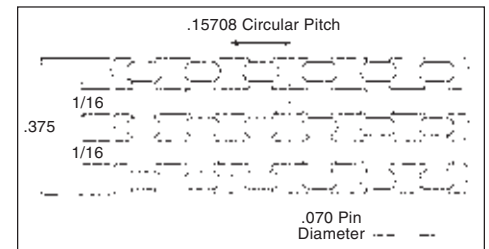

For Triple Core Belts use:

F20TS-XX for Steel Core

Standard triple core belts have been established utilizing the same number of drive pins as shown on the adjoining tabulation.

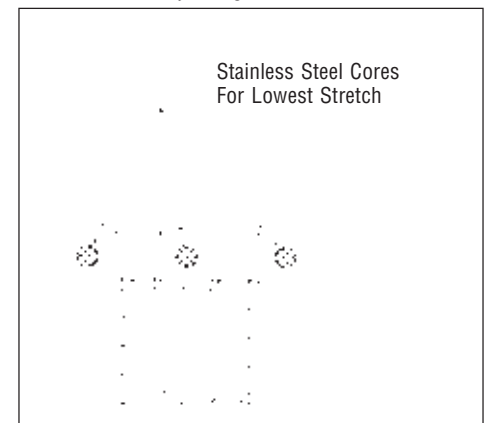

Note: Triple core belt used the same pulleys as the single core belts FLG and FLH Series.

For field splicing triple core, use Kit F20T-SK. See page 5-5.

NO-SLIP PULLEYS

20DP, .15708CP — 1/8, 3/16, 1/4, Bores For FLA, FLS and F20TS No-Slip, Single and Triple Core Drive Belts

PIN HUB

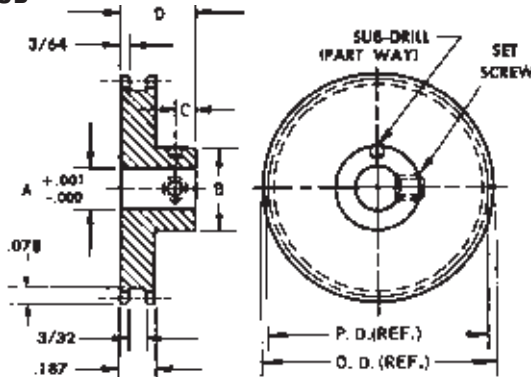

Material: 303 Stainless Steel
2024-T4 Aluminum
(Anodized Before Cutting)

Dimen.	Bore Size				
	1/8"	3/16"	1/4"	4 mm	6 mm
A	.1248	.1873	.2498	.1573	.2360
B	.312	.375	.500	.375	.500
C	.09	.11	.12	.11	.12
D	.375	.406	.437	.406	.437
Set Screw	#2-56	#4-40	#6-32	M2X.4	M3X.5

For Metric Bores:

Bore	Stainless Steel	Aluminum
4 mm	MF20G1-XX	MF20G2-XX
6 mm	MF20G3-XX	MF20G4-XX

XX = Number of teeth

Pulley Data			Stainless Steel Bore Size Part Number			Aluminum Bore Size Part Number		
No. Teeth	P.D.	O.D.	.1248	.1873	.2498	.1248	.1873	.2498
10*	.500	.562	FLG1-010	FLG3-010	—	FLG2-010	FLG4-010	—
11*	.550	.612	FLG1-011	FLG3-011	—	FLG2-011	FLG4-011	—
12*	.600	.662	FLG1-012	FLG3-012	FLG5-012	FLG2-012	FLG4-012	FLG6-012
13*	.650	.712	FLG1-013	FLG3-013	FLG5-013	FLG2-013	FLG4-013	FLG6-013
14*	.700	.762	FLG1-014	FLG3-014	FLG5-014	FLG2-014	FLG4-014	FLG6-014
15*	.750	.812	FLG1-015	FLG3-015	FLG5-015	FLG2-015	FLG4-015	FLG6-015
16	.800	.862	FLG1-016	FLG3-016	FLG5-016	FLG2-016	FLG4-016	FLG6-016
17	.850	.912	FLG1-017	FLG3-017	FLG5-017	FLG2-017	FLG4-017	FLG6-017
18	.900	.962	FLG1-018	FLG3-018	FLG5-018	FLG2-018	FLG4-018	FLG6-018
19	.950	1.012	FLG1-019	FLG3-019	FLG5-019	FLG2-019	FLG4-019	FLG6-019
20	1.000	1.062	FLG1-020	FLG3-020	FLG5-020	FLG2-020	FLG4-020	FLG6-020
22	1.100	1.162	FLG1-022	FLG3-022	FLG5-022	FLG2-022	FLG4-022	FLG6-022
24	1.200	1.262	FLG1-024	FLG3-024	FLG5-024	FLG2-024	FLG4-024	FLG6-024
25	1.250	1.312	FLG1-025	FLG3-025	FLG5-025	FLG2-025	FLG4-025	FLG6-025
26	1.300	1.362	FLG1-026	FLG3-026	FLG5-026	FLG2-026	FLG4-026	FLG6-026
28	1.400	1.462	FLG1-028	FLG3-028	FLG5-028	FLG2-028	FLG4-028	FLG6-028
30	1.500	1.562	FLG1-030	FLG3-030	FLG5-030	FLG2-030	FLG4-030	FLG6-030
32	1.600	1.662	FLG1-032	FLG3-032	FLG5-032	FLG2-032	FLG4-032	FLG6-032
35	1.750	1.812	FLG1-035	FLG3-035	FLG5-035	FLG2-035	FLG4-035	FLG6-035
36	1.800	1.862	FLG1-036	FLG3-036	FLG5-036	FLG2-036	FLG4-036	FLG6-036
40	2.000	2.062	FLG1-040	FLG3-040	FLG5-040	FLG2-040	FLG4-040	FLG6-040
45	2.250	2.312	FLG1-045	FLG3-045	FLG5-045	FLG2-045	FLG4-045	FLG6-045
50	2.500	2.562	—	FLG3-050	FLG5-050	—	FLG4-050	FLG6-050
60	3.000	3.062	—	FLG3-060	FLG5-060	—	FLG4-060	FLG6-060
70	3.500	3.562	—	FLG3-070	FLG5-070	—	FLG4-070	FLG6-070
80	4.000	4.062	—	FLG3-080	FLG5-080	—	FLG4-080	FLG6-080

* Recommended for use as an idler only

See Note Below.

SPLIT HUB

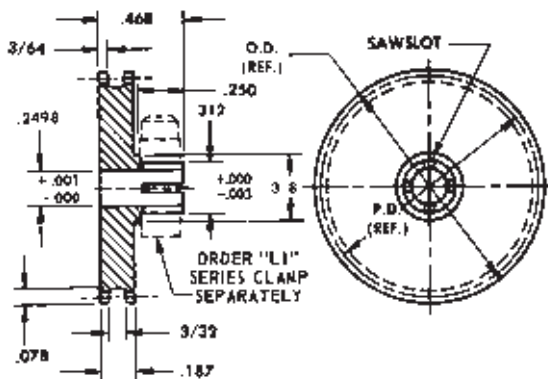

Note:

Other Size Bores Available, Consult Factory.
For unlisted number of teeth, specify the number of teeth desired as the last digits in the part number.
EXAMPLE: For a 52-tooth stainless steel pulley, specify Part Number: FLH5-052.
For number of teeth above or below listed sizes, consult factory.

Pulley Data			Stainless Steel Part Number	Aluminum Part Number
No. Teeth	P.D.	O.D.	.2498 Bore Size	.2498 Bore Size
12*	.600	.662	FLH5-012	FLH6-012
13*	.650	.712	FLH5-013	FLH6-013
14*	.700	.762	FLH5-014	FLH6-014
15*	.750	.812	FLH5-015	FLH6-015
16	.800	.862	FLH5-016	FLH6-016
17	.850	.912	FLH5-017	FLH6-017
18	.900	.962	FLH5-018	FLH6-018
19	.950	1.012	FLH5-019	FLH6-019
20	1.000	1.062	FLH5-020	FLH6-020
22	1.100	1.162	FLH5-022	FLH6-022
24	1.200	1.262	FLH5-024	FLH6-024
25	1.250	1.312	FLH5-025	FLH6-025
26	1.300	1.362	FLH5-026	FLH6-026
28	1.400	1.462	FLH5-028	FLH6-028
30	1.500	1.562	FLH5-030	FLH6-030
32	1.600	1.662	FLH5-032	FLH6-032
35	1.750	1.812	FLH5-035	FLH6-035
36	1.800	1.862	FLH5-036	FLH6-036
40	2.000	2.062	FLH5-040	FLH6-040
45	2.250	2.312	FLH5-045	FLH6-045

* Recommended for use as an idler only

NO-SLIP POSITIVE DRIVE BELT

20DP, .15708CP — Twin Core

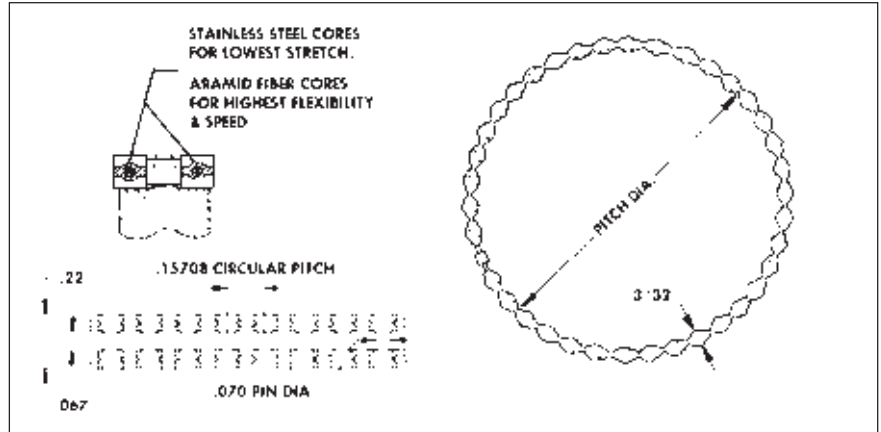

Material:

FMA Series: Molded Polyurethane, .032 diameter Aramid Fiber (Kevlar) Cores.

Color: Clear

FMS Series: Molded Polyurethane, .032 diameter Stainless Steel Cores.

Color: Clear

Number of Drive Pins	Length (Ref.)	Part No. Aramid Core	Part No. Steel Core
30	4.712	FMA-030	FMS-030
35	5.498	FMA-035	FMS-035
40	6.283	FMA-040	FMS-040
45	7.068	FMA-045	FMS-045
50	7.854	FMA-050	FMS-050
55	8.639	FMA-055	FMS-055
60	9.424	FMA-060	FMS-060
70	10.995	FMA-070	FMS-070
80	12.566	FMA-080	FMS-080
90	14.137	FMA-090	FMS-090
100	15.708	FMA-100	FMS-100
110	17.278	FMA-110	FMS-110
120	18.849	FMA-120	FMS-120
130	20.420	FMA-130	FMS-130
140	21.991	FMA-140	FMS-140
150	23.562	FMA-150	FMS-150
160	25.132	FMA-160	FMS-160
170	26.703	FMA-170	FMS-170
180	28.274	FMA-180	FMS-180
190	29.845	FMA-190	FMS-190
200	31.416	FMA-200	FMS-200

Number of Drive Pins	Length (Ref.)	Part No. Aramid Core	Part No. Steel Core
210	32.986	FMA-210	FMS-210
220	34.557	FMA-220	FMS-220
230	36.128	FMA-230	FMS-230
240	37.699	FMA-240	FMS-240
250	39.270	FMA-250	FMS-250
260	40.840	FMA-260	FMS-260
270	42.411	FMA-270	FMS-270
280	43.982	FMA-280	FMS-280
290	45.553	FMA-290	FMS-290
300	47.124	FMA-300	FMS-300
310	48.694	FMA-310	FMS-310
320	50.265	FMA-320	FMS-320
330	51.836	FMA-330	FMS-330
340	53.407	FMA-340	FMS-340
350	54.978	FMA-350	FMS-350
360	56.548	FMA-360	FMS-360
370	58.119	FMA-370	FMS-370
380	59.690	FMA-380	FMS-380
400	62.832	FMA-400	FMS-400
420	65.973	FMA-420	FMS-420
440	69.115	FMA-440	FMS-440

Bulk Lengths — Not Spliced

Length	Aramid Core Part Number	Steel Core Part Number
5 Ft	FMA-5FT	FMS-5FT
10 Ft	FMA-10FT	FMS-10FT
25 Ft	FMA-25FT	FMS-25FT
50 Ft	FMA-50FT	FMS-50FT
100 Ft	FMA-100FT	FMS-100FT

For field splicing use Kit FM-SK.
See page 5-5.

For other length belts longer than the minimum listed, substitute the desired number of drive pins at the end of the part number.

20DP (.15708 CP) SINGLE CORE NO-SLIP BELTS, SERIES FLA & FLS

Similar high strength, hi-flex design as "FL" series, but with twin cores providing added strength for higher tensile loads. Loads are carried by two cores, reducing stretch by a factor of two. Sprockets have only one row of teeth, resulting in cost savings vs pulleys with two rows of teeth. Recommended for higher load applications where twisting of the belt is not required.

NO-SLIP SPROCKETS

20DP, .15708CP — 1/8, 3/16, 1/4, Bores For FMA & FMS No-Slip, Twin Core Drive Belts

PIN HUB

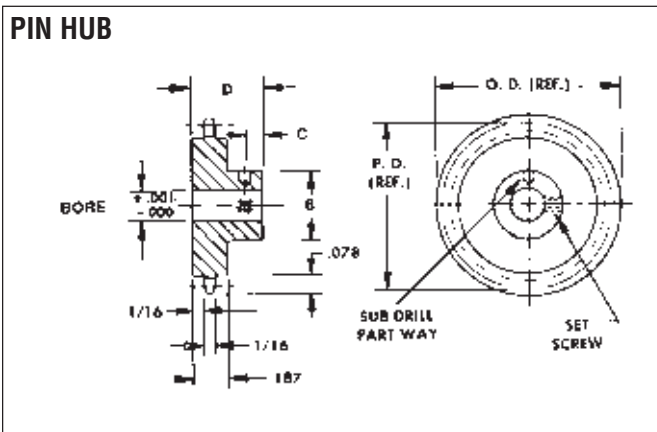

Material: 303 Stainless Steel
2024-T4 Aluminum
(Anodized Before Cutting)

Dimen.	Bore Size				
	1/8"	3/16"	1/4"	4 mm	6 mm
A	.1248	.1873	.2498	.1573	.2360
B	.312	.375	.500	.375	.500
C	.09	.11	.12	.11	.12
D	.375	.406	.437	.406	.437
Set Screw	#2-56	#4-40	#6-32	M2X.4	M3X.5

Sprocket Data			Stainless Steel Bore Size Part Number			Aluminum Bore Size Part Number		
No. Teeth	P.D.	O.D.	.1248	.1873	.2498	.1248	.1873	.2498
10*	.500	.562	FMG1-010	FMG3-010	—	FMG2-010	FMG4-010	—
11*	.550	.612	FMG1-011	FMG3-011	—	FMG2-011	FMG4-011	—
12*	.600	.662	FMG1-012	FMG3-012	FMG5-012	FMG2-012	FMG4-012	FMG6-012
13*	.650	.712	FMG1-013	FMG3-013	FMG5-013	FMG2-013	FMG4-013	FMG6-013
14*	.700	.762	FMG1-014	FMG3-014	FMG5-014	FMG2-014	FMG4-014	FMG6-014
15*	.750	.812	FMG1-015	FMG3-015	FMG5-015	FMG2-015	FMG4-015	FMG6-015
16	.800	.862	FMG1-016	FMG3-016	FMG5-016	FMG2-016	FMG4-016	FMG6-016
17	.850	.912	FMG1-017	FMG3-017	FMG5-017	FMG2-017	FMG4-017	FMG6-017
18	.900	.962	FMG1-018	FMG3-018	FMG5-018	FMG2-018	FMG4-018	FMG6-018
19	.950	1.012	FMG1-019	FMG3-019	FMG5-019	FMG2-019	FMG4-019	FMG6-019
20	1.000	1.062	FMG1-020	FMG3-020	FMG5-020	FMG2-020	FMG4-020	FMG6-020
22	1.100	1.162	FMG1-022	FMG3-022	FMG5-022	FMG2-022	FMG4-022	FMG6-022
24	1.200	1.262	FMG1-024	FMG3-024	FMG5-024	FMG2-024	FMG4-024	FMG6-024
25	1.250	1.312	FMG1-025	FMG3-025	FMG5-025	FMG2-025	FMG4-025	FMG6-025
26	1.300	1.362	FMG1-026	FMG3-026	FMG5-026	FMG2-026	FMG4-026	FMG6-026
28	1.400	1.462	FMG1-028	FMG3-028	FMG5-028	FMG2-028	FMG4-028	FMG6-028
30	1.500	1.562	FMG1-030	FMG3-030	FMG5-030	FMG2-030	FMG4-030	FMG6-030
32	1.600	1.662	FMG1-032	FMG3-032	FMG5-032	FMG2-032	FMG4-032	FMG6-032
35	1.750	1.812	FMG1-035	FMG3-035	FMG5-035	FMG2-035	FMG4-035	FMG6-035
36	1.800	1.862	FMG1-036	FMG3-036	FMG5-036	FMG2-036	FMG4-036	FMG6-036
40	2.000	2.062	FMG1-040	FMG3-040	FMG5-040	FMG2-040	FMG4-040	FMG6-040
45	2.250	2.312	FMG1-045	FMG3-045	FMG5-045	FMG2-045	FMG4-045	FMG6-045
50	2.500	2.562	—	FMG3-050	FMG5-050	—	FMG4-050	FMG6-050
60	3.000	3.062	—	FMG3-060	FMG5-060	—	FMG4-060	FMG6-060
70	3.500	3.562	—	FMG3-070	FMG5-070	—	FMG4-070	FMG6-070
80	4.000	4.062	—	FMG3-080	FMG5-080	—	FMG4-080	FMG6-080

* Recommended for use as an idler only

See Note Below.

For Metric Bores:

Bore	Stainless Steel	Aluminum
4 mm	MFMG1-XX	MFMG2-XX
6 mm	MFMG3-XX	MFMG4-XX

XX = Number of teeth

SPLIT HUB

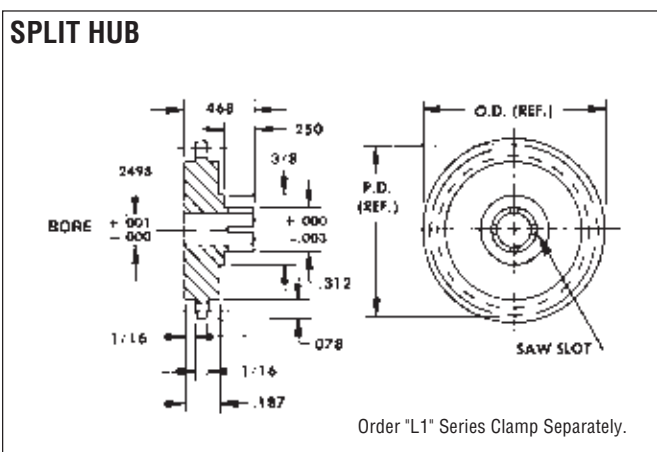

Note:

Other Size Bores Available, Consult Factory.
For unlisted number of teeth, specify the number of teeth desired as the last digits in the part number.

EXAMPLE: For a 52-tooth stainless steel sprocket, specify Part Number: FMH5-052

For number of teeth above or below listed sizes, consult factory.

Sprocket Data			Stainless Steel Part Number	Aluminum Part Number
No. Teeth	P.D.	O.D.	.2498 Bore Size	.2498 Bore Size
12*	.600	.662	FMH5-012	FMH6-012
13*	.650	.712	FMH5-013	FMH6-013
14*	.700	.762	FMH5-014	FMH6-014
15*	.750	.812	FMH5-015	FMH6-015
16	.800	.862	FMH5-016	FMH6-016
17	.850	.912	FMH5-017	FMH6-017
18	.900	.962	FMH5-018	FMH6-018
19	.950	1.012	FMH5-019	FMH6-019
20	1.000	1.062	FMH5-020	FMH6-020
22	1.100	1.162	FMH5-022	FMH6-022
24	1.200	1.262	FMH5-024	FMH6-024
25	1.250	1.312	FMH5-025	FMH6-025
26	1.300	1.362	FMH5-026	FMH6-026
28	1.400	1.462	FMH5-028	FMH6-028
30	1.500	1.562	FMH5-030	FMH6-030
32	1.600	1.662	FMH5-032	FMH6-032
35	1.750	1.812	FMH5-035	FMH6-035
36	1.800	1.862	FMH5-036	FMH6-036
40	2.000	2.062	FMH5-040	FMH6-040
45	2.250	2.312	FMH5-045	FMH6-045

* Recommended for use as an idler only

NO-SLIP POSITIVE DRIVE BELT "CHAIN"

.25 (1/4") Pitch

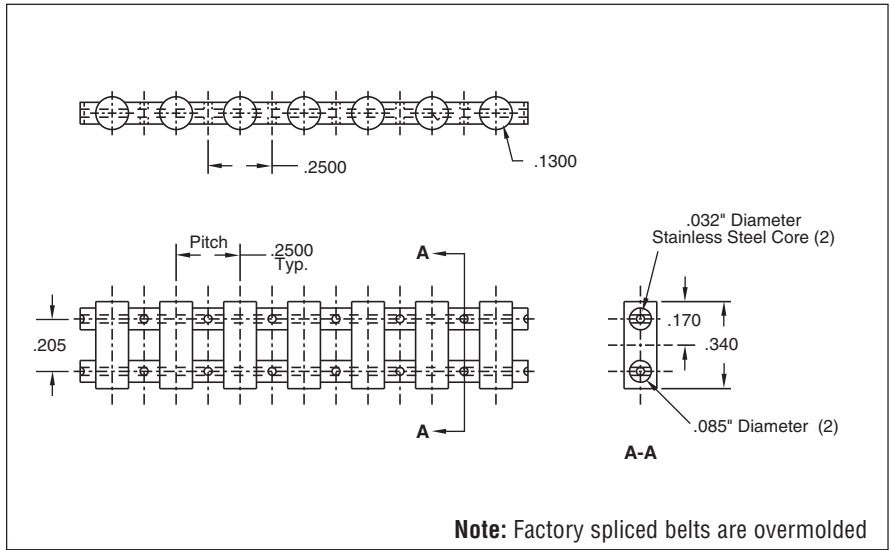

Material:

F25CS Series: Molded Polyurethane, .032 diameter Stainless Steel Cores.
Color: Light Brown

F25CA Series: Molded Polyurethane, .032 diameter Aramid (Kevlar) Cores.
Color: Light Brown

Number Of Drive Pins	Length (Ref.)	Part Number *	Number Of Drive Pins	Length (Ref.)	Part Number *
40	10.000	F25CS-40	220	55.000	F25CS-220
50	12.500	F25CS-50	230	57.500	F25CS-230
60	15.000	F25CS-60	240	60.000	F25CS-240
70	17.500	F25CS-70	250	62.500	F25CS-250
80	20.000	F25CS-80	260	65.000	F25CS-260
90	22.500	F25CS-90	270	67.500	F25CS-270
100	25.000	F25CS-100	280	70.000	F25CS-280
110	27.500	F25CS-110	290	72.500	F25CS-290
120	30.000	F25CS-120	300	75.000	F25CS-300
130	32.500	F25CS-130	310	77.500	F25CS-310
140	35.000	F25CS-140	320	80.000	F25CS-320
150	37.500	F25CS-150	330	82.500	F25CS-330
160	40.000	F25CS-160	340	85.000	F25CS-340
170	42.500	F25CS-170	350	87.500	F25CS-350
180	45.000	F25CS-180	370	92.500	F25CS-370
190	47.500	F25CS-190	380	95.000	F25CS-380
200	50.000	F25CS-200	390	97.500	F25CS-390
210	52.500	F25CS-210			

* For Aramid Cores, substitute A for S in the part number

For other length belts longer than the minimum listed, substitute the desired number of drive pins at the end of the part number.

Bulk Footage — Not Spliced

Length	Part Number
5 Ft	F25CS-5FT
10 Ft	F25CS-10FT
25 Ft	F25CS-25FT
50 Ft	F25CS-50FT
100 Ft	F25CS-100FT

Special length belts and other bulk lengths available. Consult factory.

For field splicing use Kit F25C-SK. See page 5-5.

* For Aramid Cores, substitute A for S in the part number

.25 Pitch Twin Core No-Slip Belts — Series F25CS

Designed to provide an economical alternative to 25-pitch roller chain, with smoother motion. Drive pins are 44% larger in diameter than FRA & FRS series.

NO-SLIP SPROCKETS

.25 (1/4") Pitch 1/4, 3/8, 1/2 — 8 mm, 10 mm & 12 mm Bores for F25 Twin Core Drive Belts

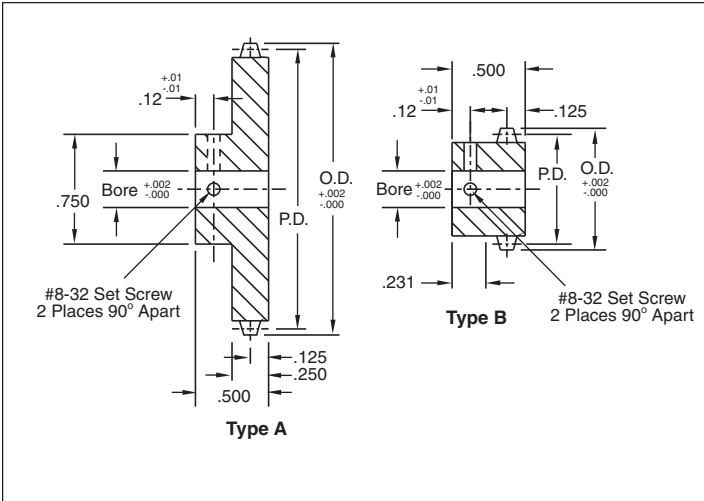

Number Of Teeth	Type	P.D. (Inches)	O.D. (Inches)	Bore Size / Part Number		
				.250	.375	.500
9 *	B	.7162	.836	F25G4-9	F25G6-9	F25G8-9
10	B	.7958	.915	F25G4-10	F25G6-10	F25G8-10
12	A	.9549	1.074	F25G4-12	F25G6-12	F25G8-12
13	A	1.0345	1.154	F25G4-13	F25G6-13	F25G8-13
14	A	1.1141	1.234	F25G4-14	F25G6-14	F25G8-14
15	A	1.1936	1.313	F25G4-15	F25G6-15	F25G8-15
16	A	1.2732	1.393	F25G4-16	F25G6-16	F25G8-16
18	A	1.4324	1.552	F25G4-18	F25G6-18	F25G8-18
20	A	1.5915	1.711	F25G4-20	F25G6-20	F25G8-20
24	A	1.9098	2.029	F25G4-24	F25G6-24	F25G8-24
25	A	1.9894	2.109	F25G4-25	F25G6-25	F25G8-25
28	A	2.2281	2.348	F25G4-28	F25G6-28	F25G8-28
30	A	2.3873	2.507	F25G4-30	F25G6-30	F25G8-30
36	A	2.8648	2.984	F25G4-36	F25G6-36	F25G8-36
40	A	3.1831	3.303	F25G4-40	F25G6-40	F25G8-40
48	A	3.8197	3.939	F25G4-48	F25G6-48	F25G8-48
60	A	4.7746	4.894	F25G4-60	F25G6-60	F25G8-60
72	A	5.7296	5.849	F25G4-72	F25G6-72	F25G8-72

* Recommended for use as an idler only

See Note Below.

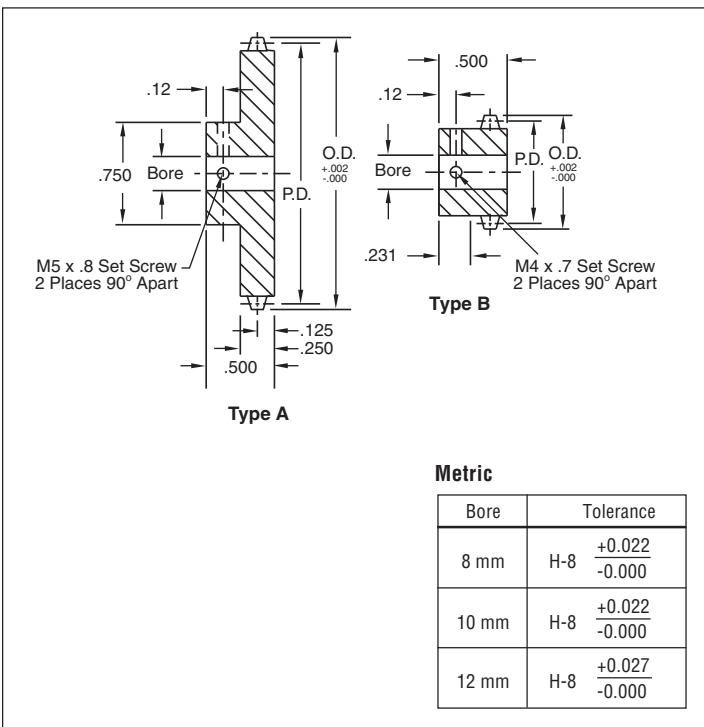

Metric	
Bore	Tolerance
8 mm	H-8 +0.022 -0.000
10 mm	H-8 +0.022 -0.000
12 mm	H-8 +0.027 -0.000

Number Of Teeth	Type	P.D. (Inches)	O.D. (Inches)	Bore Size / Part Number (Metric)		
				8 mm	10 mm	12 mm
9 *	B	.7162	.836	MF25G4-9	MF25G6-9	MF25G8-9
10	B	.7958	.915	MF25G4-10	MF25G6-10	MF25G8-10
12	A	.9549	1.074	MF25G4-12	MF25G6-12	MF25G8-12
13	A	1.0345	1.154	MF25G4-13	MF25G6-13	MF25G8-13
14	A	1.1141	1.234	MF25G4-14	MF25G6-14	MF25G8-14
15	A	1.1936	1.313	MF25G4-15	MF25G6-15	MF25G8-15
16	A	1.2732	1.393	MF25G4-16	MF25G6-16	MF25G8-16
18	A	1.4324	1.552	MF25G4-18	MF25G6-18	MF25G8-18
20	A	1.5915	1.711	MF25G4-20	MF25G6-20	MF25G8-20
24	A	1.9098	2.029	MF25G4-24	MF25G6-24	MF25G8-24
25	A	1.9894	2.109	MF25G4-25	MF25G6-25	MF25G8-25
28	A	2.2281	2.348	MF25G4-28	MF25G6-28	MF25G8-28
30	A	2.3873	2.507	MF25G4-30	MF25G6-30	MF25G8-30
36	A	2.8648	2.984	MF25G4-36	MF25G6-36	MF25G8-36
40	A	3.1831	3.303	MF25G4-40	MF25G6-40	MF25G8-40
48	A	3.8197	3.939	MF25G4-48	MF25G6-48	MF25G8-48
60	A	4.7746	4.894	MF25G4-60	MF25G6-60	MF25G8-60
72	A	5.7296	5.849	MF25G4-72	MF25G6-72	MF25G8-72

* Recommended for use as an idler only

Note:

Other Size Bores Available, Consult Factory.
For unlisted number of teeth, specify the number of teeth desired as the last digits in the part number.

EXAMPLE: For a 52-tooth 1/4" bore sprocket, specify Part Number: F25G4-52
For number of teeth above or below listed sizes, consult factory.

NO-SLIDE TIMING BELTS

40 DP (.0816 Pitch), 1/8" Wide — Polyurethane Belt

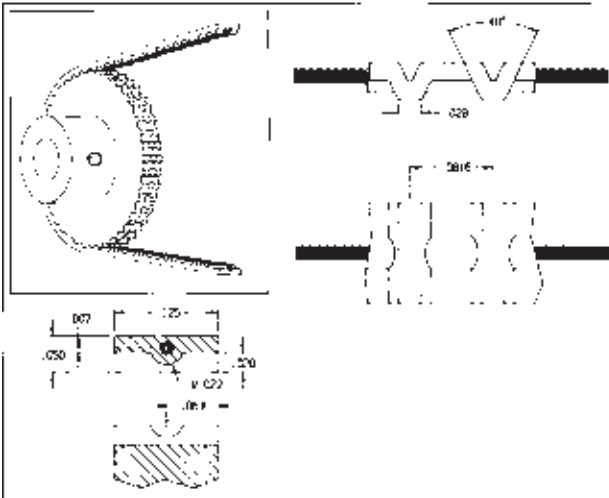

Material: Molded Polyurethane with .018" Dia. Stainless Steel Core

Color: Clear

Maximum Tensile Strength: 25 Lbs.

Note: For maximum life use working tension of less than 4 lbs.

No Of Grooves	Length (Ref.)	Part Number	No Of Grooves	Length (Ref.)	Part Number
24*	1.9584	F8BS-24	114	9.3024	F8BS-114
44	3.5904	F8BS-44	120	9.7920	F8BS-120
45	3.6720	F8BS-45	123	10.0368	F8BS-123
48	3.9168	F8BS-48	126	10.2816	F8BS-126
51	4.1616	F8BS-51	132	10.7721	F8BS-132
52	4.2432	F8BS-52	139	11.3424	F8BS-139
53	4.3248	F8BS-53	140	11.4240	F8BS-140
60	4.8960	F8BS-60	150	12.2400	F8BS-150
64	5.2224	F8BS-64	162	13.2192	F8BS-162
66	5.3856	F8BS-66	175	14.2800	F8BS-175
67	5.4672	F8BS-67	184	15.0144	F8BS-184
72	5.8752	F8BS-72	193	15.7488	F8BS-193
77	6.2832	F8BS-77	214	17.4624	F8BS-214
88	7.1808	F8BS-88	228	18.6048	F8BS-228
96	7.8336	F8BS-96	245	19.9920	F8BS-245
98	7.9968	F8BS-98	249	20.3184	F8BS-249
102	8.3232	F8BS-102	251	20.4816	F8BS-251
109	8.8944	F8BS-109	264	21.5424	F8BS-264
110	8.9760	F8BS-110			

* Splice not overmolded on 24 grooves
For other length belts longer than the minimum listed, substitute the desired number of drive pins at the end of the part number.

Bulk Lengths — Not Spliced

Length	Part Number
5 Ft	F8BS-5FT
10 Ft	F8BS-10FT
25 Ft	F8BS-25FT
50 Ft	F8BS-50FT
100 Ft	F8BS-100FT

For field splicing use kit F8B-SK. See page 5-5.

NO-SLIDE TIMING PULLEYS

40 D.P. (.0816 Pitch), No Flange, Grooved Pulley for 1/8" Wide Belts

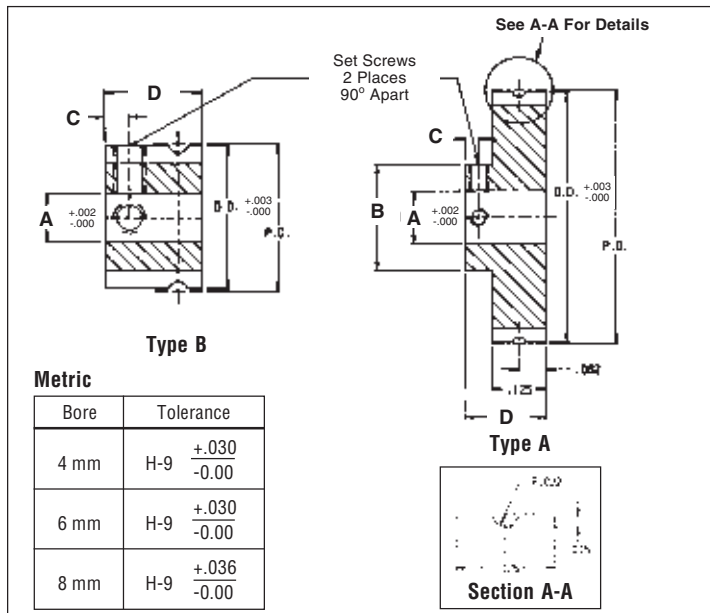

Material: 2024-T4 Aluminum (anodized before cutting)

Note 1: For metric bores prefix part numbers with letter M. XX = number of teeth

4 mm bore part number: MF8P4-XX

6 mm bore part number: MF8P6-XX

8 mm bore part number: MF8P8-XX

Example: Part number for a 6 mm bore with 40 teeth is MF8P6-40

Note 2: Other number of teeth available for inch and metric pulleys

No. of Teeth	Type	Pitch Dia.	Outside Dia.	Bore Size / Part Number		
				.125	.187	.250
14 *	B	.3636	.349	F8P2-14	F8P3-14	—
15 *	B	.3896	.375	F8P2-15	F8P3-15	—
18 *	B	.4675	.453	F8P2-18	F8P3-18	F8P4-18
20	A	.5195	.505	F8P2-20	F8P3-20	F8P4-20
24	A	.6234	.609	F8P2-24	F8P3-24	F8P4-24
25	A	.6494	.635	F8P2-25	F8P3-25	F8P4-25
28	A	.7273	.713	F8P2-28	F8P3-28	F8P4-28
30	A	.7792	.765	F8P2-30	F8P3-30	F8P4-30
32	A	.8312	.817	F8P2-32	F8P3-32	F8P4-32
34	A	.8831	.869	F8P2-34	F8P3-34	F8P4-34
36	A	.9351	.921	F8P2-36	F8P3-36	F8P4-36
38	A	.9870	.973	F8P2-38	F8P3-38	F8P4-38
40	A	1.0390	1.025	F8P2-40	F8P3-40	F8P4-40
42	A	1.0909	1.076	F8P2-42	F8P3-42	F8P4-42
44	A	1.1429	1.128	F8P2-44	F8P3-44	F8P4-44
48	A	1.2468	1.232	F8P2-48	F8P3-48	F8P4-48
50	A	1.2987	1.284	F8P2-50	F8P3-50	F8P4-50
54	A	1.4026	1.388	F8P2-54	F8P3-54	F8P4-54
60	A	1.5584	1.544	F8P2-60	F8P3-60	F8P4-60
72	A	1.8701	1.856	F8P2-72	F8P3-72	F8P4-72
75	A	1.9481	1.934	F8P2-75	F8P3-75	F8P4-75
80	A	2.0779	2.063	F8P2-80	F8P3-80	F8P4-80
84	A	2.1818	2.167	F8P2-84	F8P3-84	F8P4-84
88	A	2.2857	2.271	F8P2-88	F8P3-88	F8P4-88
90	A	2.3377	2.323	F8P2-90	F8P3-90	F8P4-90
96	A	2.4935	2.479	F8P2-96	F8P3-96	F8P4-96
98	A	2.5455	2.531	F8P2-98	F8P3-98	F8P4-98
100	A	2.5974	2.583	F8P2-100	F8P3-100	F8P4-100
120	A	3.1169	3.102	F8P2-120	F8P3-120	F8P4-120

* Recommended for use as an idler only

Dimen. (In.)	Bore Size					
	1/8"	3/16"	1/4"	4 mm	6 mm	8 mm
A	.1248	.1873	.2498	.1573	.2360	.3148
B	.312	.375	.500	.312	.375	.500
C	.09	.11	.12	.09	.11	.12
D	.312	.343	.375	.312	.343	.375
Set Screw	#2-56	#4-40	#6-32	M2X.4	M3X.5	M4X.7

NO-SLIDE TIMING BELTS

1/5 (.200) Pitch, 1/4" Wide Polyurethane Belts

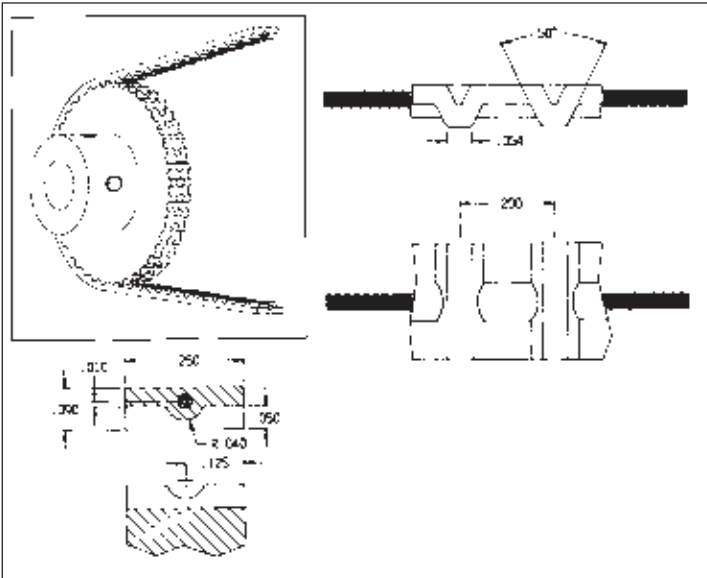

No Of Grooves	Length (Ref.)	Part Number	No Of Grooves	Length (Ref.)	Part Number
20*	4.00	F20BS-20	115	23.00	F20BS-115
25*	5.00	F20BS-25	120	24.00	F20BS-120
30*	6.00	F20BS-30	125	25.00	F20BS-125
35	7.00	F20BS-35	130	26.00	F20BS-130
40	8.00	F20BS-40	135	27.00	F20BS-135
45	9.00	F20BS-45	140	28.00	F20BS-140
50	10.00	F20BS-50	145	29.00	F20BS-145
55	11.00	F20BS-55	150	30.00	F20BS-150
60	12.00	F20BS-60	155	31.00	F20BS-155
65	13.00	F20BS-65	160	32.00	F20BS-160
70	14.00	F20BS-70	165	33.00	F20BS-165
75	15.00	F20BS-75	170	34.00	F20BS-170
80	16.00	F20BS-80	175	35.00	F20BS-175
85	17.00	F20BS-85	180	36.00	F20BS-180
90	18.00	F20BS-90	185	37.00	F20BS-185
95	19.00	F20BS-95	190	38.00	F20BS-190
100	20.00	F20BS-100	195	39.00	F20BS-195
105	21.00	F20BS-105	200	40.00	F20BS-200
110	22.00	F20BS-110	210	42.00	F20BS-210

* Splice not overmolded on less than 35 grooves

For other length belts longer than the minimum listed, substitute the desired number of drive pins at the end of the part number.

Note: For Aramid (Kevlar) fiber core, change Part No. to F20BA-□□□
Consult factory for availability

Bulk Lengths — Not Spliced

Length	Part Number
5 Ft	F20BS-5FT
10 Ft	F20BS-10FT
25 Ft	F20BS-25FT
50 Ft	F20BS-50FT
100 Ft	F20BS-100FT

For field splicing use kit F20B-SK. See page 5-5.

Material: Molded Polyurethane with .032" Dia. Stainless Steel Core

Color: Red, Aramid (Kevlar) Core Yellow

Maximum Tensile Strength: 50 Lbs.

Note: For maximum life use working tension of less than 10 lbs.

NO-SLIDE TIMING PULLEYS

1/5 (.200) Pitch, No Flange Groove Pulleys for 1/4" Wide Belts

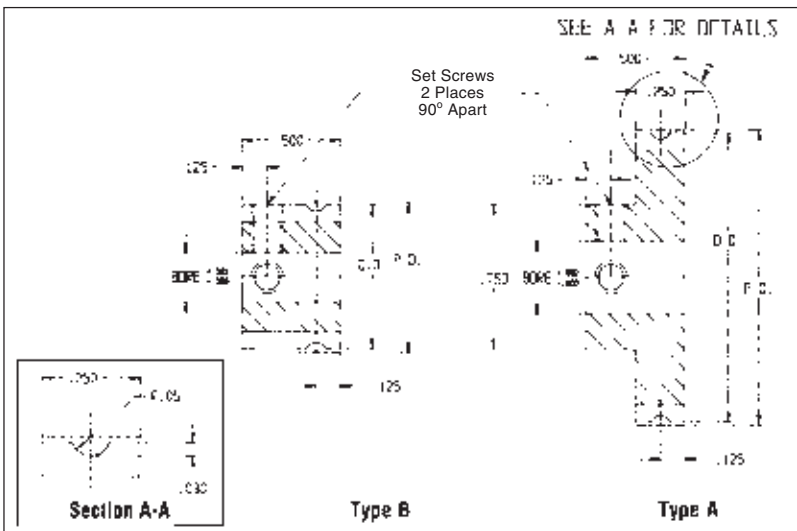

No. of Teeth	Type	Pitch Dia.	Outside Dia.	STD Bore / Part Number		
				.250	.375	.500
10*	B	.6366	.616	F20P4-10	—	—
11*	B	.7003	.680	F20P4-11	F20P6-11	—
12	B	.7639	.743	F20P4-12	F20P6-12	F20P8-12
14	A	.8913	.871	F20P4-14	F20P6-14	F20P8-14
15	A	.9549	.934	F20P4-15	F20P6-15	F20P8-15
16	A	1.0186	.998	F20P4-16	F20P6-16	F20P8-16
17	A	1.0823	1.062	F20P4-17	F20P6-17	F20P8-17
18	A	1.1459	1.125	F20P4-18	F20P6-18	F20P8-18
19	A	1.2096	1.189	F20P4-19	F20P6-19	F20P8-19
20	A	1.2732	1.253	F20P4-20	F20P6-20	F20P8-20
21	A	1.3369	1.316	F20P4-21	F20P6-21	F20P8-21
22	A	1.4006	1.380	F20P4-22	F20P6-22	F20P8-22
23	A	1.4642	1.444	F20P4-23	F20P6-23	F20P8-23
24	A	1.5279	1.507	F20P4-24	F20P6-24	F20P8-24
25	A	1.5916	1.571	F20P4-25	F20P6-25	F20P8-25
27	A	1.7189	1.698	F20P4-27	F20P6-27	F20P8-27
28	A	1.7825	1.762	F20P4-28	F20P6-28	F20P8-28
29	A	1.8462	1.826	F20P4-29	F20P6-29	F20P8-29
30	A	1.9099	1.889	F20P4-30	F20P6-30	F20P8-30
32	A	2.0372	2.017	F20P4-32	F20P6-32	F20P8-32
36	A	2.2918	2.271	F20P4-36	F20P6-36	F20P8-36
40	A	2.5465	2.526	F20P4-40	F20P6-40	F20P8-40
42	A	2.6738	2.653	F20P4-42	F20P6-42	F20P8-42
44	A	2.8011	2.781	F20P4-44	F20P6-44	F20P8-44
45	A	2.8648	2.844	F20P4-45	F20P6-45	F20P8-45
48	A	3.0558	3.035	F20P4-48	F20P6-48	F20P8-48
50	A	3.1831	3.163	F20P4-50	F20P6-50	F20P8-50
60	A	3.8197	3.799	F20P4-60	F20P6-60	F20P8-60
72	A	4.5837	4.563	F20P4-72	F20P6-72	F20P8-72

* Recommended for use as an idler only

Material: 2024-T4 Aluminum (anodized before cutting)

Note: For metric bores prefix part numbers with letter M.
XX = number of teeth

8 mm bore part number: MF20P8-XX

10 mm bore part number: MF20P10-XX

12 mm bore part number: MF20P12-XX

Example: Part number for a 1/5" pitch No-Slide pulley with 50 teeth and 12 mm bore is MF20P12-50

Set Screw Size		
Bore		
Inch	8 mm	10 & 12 mm
8-32	M4X.7	M5X.8

NO-SLIDE TIMING BELTS

3/8" Pitch, 1/2" Wide — Polyurethane Belt

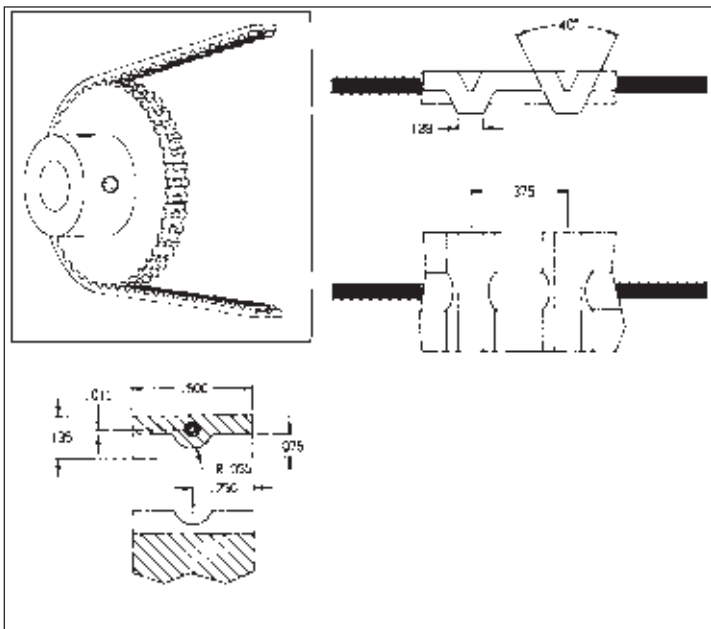

Material: Molded Polyurethane with .047" Diameter Stainless Steel Core

Color: Blue

Maximum Tensile Strength: 125 Lbs.

Note: For maximum life use working tension of less than 25 lbs.

No Of Grooves	Length (Ref.)	Part Number	No Of Grooves	Length (Ref.)	Part Number
20	7.500	F37BS-20	98	36.750	F37BS-98
22	8.250	F37BS-22	100	37.500	F37BS-100
24	9.000	F37BS-24	104	39.000	F37BS-104
26	9.750	F37BS-26	108	40.500	F37BS-108
28	10.500	F37BS-28	112	42.000	F37BS-112
30	11.250	F37BS-30	116	43.500	F37BS-116
33	12.375	F37BS-33	120	45.000	F37BS-120
36	13.500	F37BS-36	124	46.500	F37BS-124
40	15.000	F37BS-40	128	48.000	F37BS-128
45	16.875	F37BS-45	132	49.500	F37BS-132
50	18.750	F37BS-50	136	51.000	F37BS-136
56	21.000	F37BS-56	140	52.500	F37BS-140
60	22.500	F37BS-60	144	54.000	F37BS-144
64	24.000	F37BS-64	148	55.500	F37BS-148
68	25.500	F37BS-68	152	57.000	F37BS-152
72	27.000	F37BS-72	156	58.500	F37BS-156
80	30.000	F37BS-80	160	60.000	F37BS-160
86	32.250	F37BS-86	176	66.000	F37BS-176
92	34.500	F37BS-92	180	67.500	F37BS-180

Factory spliced belts are overmolded

For other length belts longer than the minimum listed, substitute the desired number of drive pins at the end of the part number.

Bulk Lengths — Not Spliced

Length	Part Number
5 Ft	F37BS-5FT
10 Ft	F37BS-10FT
25 Ft	F37BS-25FT
50 Ft	F37BS-50FT
100 Ft	F37BS-100FT

For field splicing use kit F37B-SK. See page 5-5.

NO-SLIDE TIMING PULLEYS

3/8" Pitch, No-Flange Grooved Pulleys for 1/2" Wide Belts

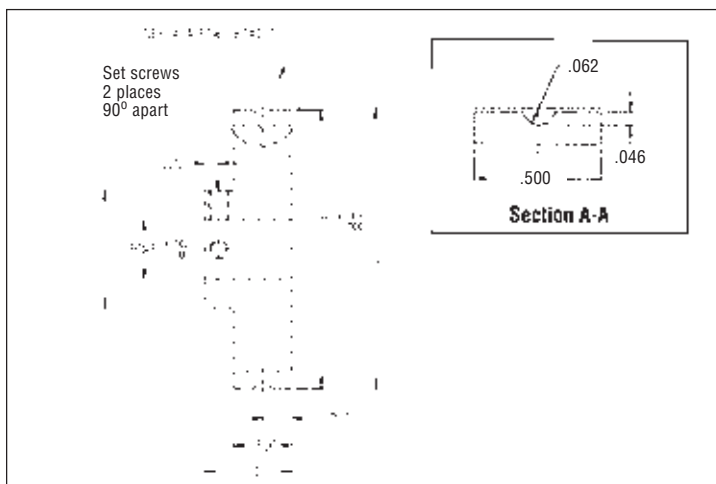

Material: 2024-T4 Aluminum (anodized before cutting)

Note: For metric bores prefix part numbers with letter M
XX = number of teeth

8 mm bore part number: MF37P8-XX

10 mm bore part number: MF37P10-XX

12 mm bore part number: MF37P12-XX

Example: Part number for 3/8" pitch No-Slide pulley with 36 teeth and a 12 mm bore is MF37P12-36

Set Screw Size		
Bore		
Inch	8 mm	10 & 12 mm
8-32	M4X.7	M5X.8

No. of Teeth	Pitch Dia.	Outside Dia.	Part No. / Bore Size		
			.250	.375	.500
10*	1.1937	1.164	F37P4-10	F37P6-10	F37P8-10
11*	1.3130	1.284	F37P4-11	F37P6-11	F37P8-11
12	1.4324	1.403	F37P4-12	F37P6-12	F37P8-12
13	1.5518	1.522	F37P4-13	F37P6-13	F37P8-13
14	1.6711	1.642	F37P4-14	F37P6-14	F37P8-14
15	1.7905	1.761	F37P4-15	F37P6-15	F37P8-15
16	1.9099	1.880	F37P4-16	F37P6-16	F37P8-16
17	2.0292	2.000	F37P4-17	F37P6-17	F37P8-17
18	2.1486	2.119	F37P4-18	F37P6-18	F37P8-18
19	2.2680	2.239	F37P4-19	F37P6-19	F37P8-19
20	2.3873	2.358	F37P4-20	F37P6-20	F37P8-20
21	2.5067	2.477	F37P4-21	F37P6-21	F37P8-21
22	2.6261	2.597	F37P4-22	F37P6-22	F37P8-22
24	2.8648	2.835	F37P4-24	F37P6-24	F37P8-24
26	3.1035	3.074	F37P4-26	F37P6-26	F37P8-26
28	3.3422	3.313	F37P4-28	F37P6-28	F37P8-28
30	3.5810	3.552	F37P4-30	F37P6-30	F37P8-30
32	3.8197	3.790	F37P4-32	F37P6-32	F37P8-32
36	4.2972	4.268	F37P4-36	F37P6-36	F37P8-36

* Recommended for use as an idler only

Note:

Other Size Bores Available, Consult Factory.
For unlisted number of teeth, specify the number of teeth desired as the last digits in the part number.

E*P*S* SYNCHRONOUS TIMING BELTS

Synchronous timing belts provide an economic means of positive power transmission. They are basically flat belts with teeth on the inside circumference resulting in high efficiencies and the capability to carry heavy loads at high speeds. The belts will maintain the relative rotational positions (timing) of pulleys. Required clearance between belt and pulley teeth (.003-.012) can result in a slight backlash.

E*P*S* synchronous timing belts are available in two materials, neoprene and urethane. Neoprene belts are faced with a nylon wear surface and reinforced with fiberglass cord. Urethane belts are reinforced with polyester cord.

PIC urethane belts' high abrasion resistance allows operation in applications where the carbon black dusting encountered with other belts cannot be tolerated. The polyester cord provides shock absorption and some vibration damping capability. This belt is well suited for high speed operation with small pulleys due to its high flexibility.

Neoprene belts offer greater load carrying capabilities. The high modulus fiberglass reinforcement allows operation without periodic retensioning.

E*P*S belts are available from PIC with two tooth forms, the usual trapezoidal form and the New, High Efficiency, HTD[®] Form. The HTD[®] belt employs a curvilinear tooth which is deeper than the trapezoidal tooth, offering the following advantages:

- Substantial belt size reductions for comparable loads. HTD[®] belts will carry 120% to 200% more horsepower than equivalent trapezoidal tooth belts.
- Speed ratios to 20:1.
- Up to 5.5 hp at speeds to 24000 rpm.
- Energy efficient replacement for "V" belt systems.
- Cost savings; narrower belts will handle larger loads.

HTD[®] belts should be considered for new designs and as cost saving replacements to solve existing problems. The stress diagram below (Figure 1) illustrates the increased load carrying ability of HTD[®] curvilinear form vs. the trapezoidal form.

The Design Guide for E*P*S HTD[®] and E*P*S drive systems will enable you to select the appropriate timing belts for your particular application.

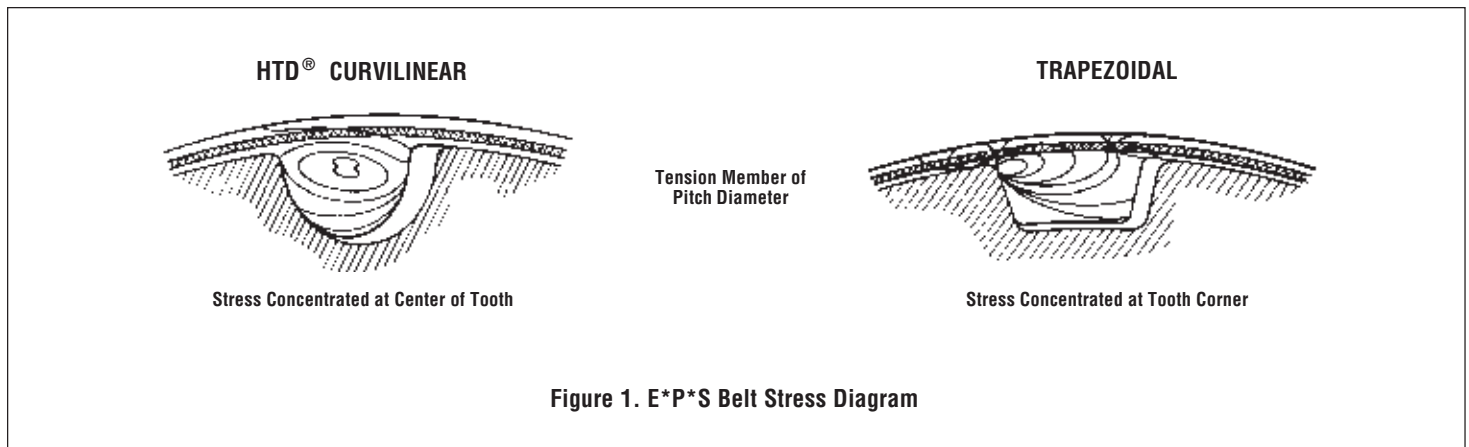

Design Guide for E*P*S HTD[®] E*P*S Drive Systems

Belt Type	Tooth Form	HTD Curvilinear				Trapezoidal			
	Pitch	3 mm	5 mm	.080	.080	.0816	1/5	1/5	3/8
	Material	Neoprene	Neoprene	Neoprene	Urethane	Urethane	Neoprene	Urethane	Neoprene
Catalog Series		EPS-F-N	EPS-G-N	EPS-A-N	EPS-A-U	EPS-C-U	EPS-D-N	EPS-D-U	EPS-J-N
Operating Temperature (°F)		-30 to +185	-30 to +185	-30 to +185	-30 to +180	-30 to +180	-30 to +185	-30 to +180	-30 to +185
Positioning Capability		Limited	Limited	Good	Good	Good	Good	Good	Good
Recommended Minimum Pitch Dia. (In.)		.38	.75	.25	.25	.25	.64	.64	1.19
Pulley Minimum No. of Teeth		10	12	10	10	10	10	10	10
Recommended Maximum Speed (RPM)		24,000	14,000	20,000	20,000	20,000	10,000	10,000	6,000
Recommended Minimum Teeth in Mesh		4	4	5	5	5	5	5	5
Recommended Maximum Working Tension (Lb./In. Width)		60	100	32	21	21	41	27	55

E*P*S DRIVER SYSTEM SELECTION PROCEDURE

In order to select the correct drive system for your application, the following procedure is recommended:

1. Determine the design horsepower (Dhp).
 $Dhp = \text{rated hp} \times SF$
 Service factors (SF) of 1.5 to 2.0 are recommended for miniature timing belts. In drive systems which require a high degree of dependability or have high stock loads, higher service factors are recommended.
2. Belt pitch and pulley selection
 - a. Using the E*P*S drive belt selection chart, select the pitch belt which has the Dhp capacity at the smaller pulley speed.
 - b. The Speed Ratio is determined by dividing the larger speed, pulley pitch diameter or groove number by the lesser speed, pulley pitch diameter or groove number.
 - c. To select the proper pulley, refer to pulley dimensions listed with corresponding pitch.
 - d. The pitch line velocity of the smaller pulley should not exceed 6500 FPM.
 $PLV = .262 \times \text{Pulley PD (in.)} \times \text{Pulley RPM}$

3. To determine the proper belt length at nominal center distance, use the following formula:

$$L = 2C + \frac{(D-d)^2}{4C} + 1.57(D+d)$$

Where L = Belt Pitch Length
 C = Center Distance
 D = Pitch Diameter Large Pulley (inches)
 d = Pitch Diameter Small Pulley (inches)

$$L_{\text{EXACT}} = 2C \cos \phi + \frac{\pi(D+d)}{2} + \frac{\pi \phi(D-d)}{180}$$

Where $\phi = \sin^{-1} \left(\frac{D-d}{2C} \right)$

4. To determine the center distance in inches when belt length and pulleys are known.

$$C_{\text{APPROX}} = \frac{K + \sqrt{K^2 - 32(D-d)^2}}{16}$$

Where $K = 4L - 6.28(D+d)$

Other useful formulas:

$$HP = \frac{\text{Torque (in.-lbs.)} \times \text{RPM}}{63025}$$

$$\text{Belt Speed fpm} = \text{Pitch Diameter} \times \text{RPM} \times .262$$

NOTE: If the number of teeth in mesh on the smaller pulley is less than 6, correct the design hp by the following factors:

Teeth in Mesh	Design HP Multiplication Factor
5	1.2
4	1.5
3	2.0
2	Suggest Alternative Drive
1	Suggest Alternative Drive

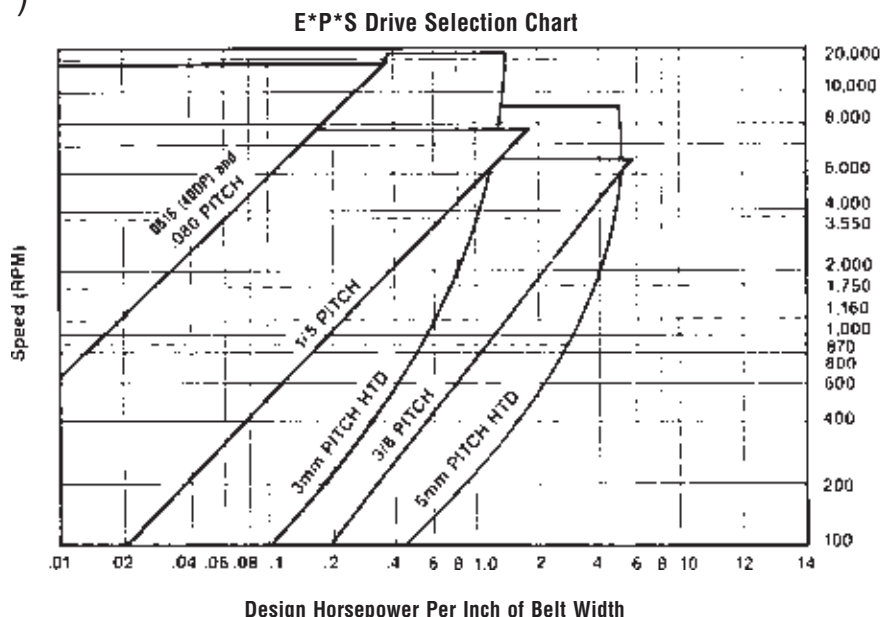

E*P*S TIMING BELTS

Special Length Timing Belts (Molds Available)

.080 Pitch

Pitch Length	No. of Teeth	Pitch Length	No. of Teeth	Pitch Length	No. of Teeth	Pitch Length	No. of Teeth
3.36	42	6.64	83	8.40	105	19.84	248
4.32	54	7.04	88	8.48	106	19.92	249
4.48	56	7.36	92	9.12	122	20.08	251
4.72	59	7.44	93	9.84	123	20.48	256
4.88	61	7.52	94	10.08	126	27.76	347
5.12	64	7.60	95	10.56	132	29.76	372
5.36	67	7.76	97	11.52	144	34.72	434
5.44	68	8.16	102	12.24	153	36.24	453
5.68	71	8.24	103	14.40	180	39.84	498
6.32	79			14.72	184	42.56	532
6.56	82			16.64	208		

.0816 Pitch

Pitch Length	No. of Teeth	Pitch Length	No. of Teeth	Pitch Length	No. of Teeth	Pitch Length	No. of Teeth
2.44	30	7.83	96	13.30	163	21.62	265
2.85	35	7.91	97	13.46	165	22.03	270
3.26	40	8.56	105	13.87	170	22.84	280
3.67	45	8.89	109	14.28	175	23.25	285
4.08	50	9.38	115	15.09	185	23.66	290
4.24	52	10.20	125	15.50	190	25.29	310
4.32	53	10.68	131	15.91	195	26.11	320
4.56	56	10.77	132	16.32	200	26.92	330
4.73	58	11.01	135	16.72	205	28.56	350
5.22	64	11.42	140	17.54	215	29.37	360
5.46	67	11.83	145	17.95	220	20.19	370
5.71	70	11.99	147	18.36	225	31.00	380
5.95	73	12.24	150	19.58	240	31.82	390
6.03	74	12.32	151	20.40	250	32.64	400
6.28	77	12.40	152	20.56	252	34.84	427
6.36	78	12.64	155	20.80	255	43.65	535
7.67	94	12.97	159	21.21	260		

1/5 (.200) Pitch

Pitch Length	No. of Teeth	Pitch Length	No. of Teeth	Pitch Length	No. of Teeth	Pitch Length	No. of Teeth	Pitch Length	No. of Teeth	Pitch Length	No. of Teeth
4.20	21	10.80	54	16.20	81	21.80	109	31.00	155	44.40	222
5.40	27	11.20	56	16.40	82	22.20	111	31.60	158	45.00	225
5.80	29	11.60	58	16.60	83	22.60	113	32.20	161	45.40	227
6.20	31	11.80	59	16.80	84	22.80	114	33.80	169	46.00	230
6.40	32	12.20	61	17.20	86	23.20	116	34.00	170	46.80	234
6.60	33	12.40	62	17.40	87	23.40	117	34.40	172	48.00	240
6.80	34	12.60	63	17.60	88	23.60	118	34.80	174	49.20	246
7.20	36	12.80	64	17.80	89	24.20	121	35.00	175	49.80	249
7.40	37	13.20	66	18.20	91	24.40	122	35.20	176	50.00	250
7.60	38	13.40	67	18.40	92	24.60	123	36.20	181	50.60	253
7.80	39	13.60	68	18.60	93	25.40	127	37.00	185	52.40	262
8.20	41	13.80	69	18.80	94	25.80	129	38.00	190	55.40	277
8.40	42	14.20	71	19.20	96	26.20	131	38.40	192	57.00	285
8.60	43	14.40	72	19.40	97	26.40	132	39.00	195	58.00	290
9.20	46	14.60	73	19.60	98	26.60	133	40.00	200	59.20	296
9.40	47	14.80	74	20.20	101	26.80	134	41.20	206	63.00	315
9.60	48	15.20	76	20.40	102	27.40	137	42.00	210	67.20	336
9.80	49	15.40	77	20.60	103	28.60	143	42.40	212	77.00	385
10.20	51	15.60	78	21.20	106	29.60	148	43.20	216	85.00	425
10.60	53	15.80	79	21.40	107	30.60	153	43.80	219		

3/8 (.375) Pitch

Pitch Length	No. of Teeth	Pitch Length	No. of Teeth
48.000	128	66.000	176
51.000	136	81.750	218
54.000	144	90.000	240
60.000	160		

3 mm HTD® Pitch

Pitch Length	No. of Teeth	Pitch Length	No. of Teeth
5.67	48	13.11	111
5.79	49	14.06	119
7.09	60	18.90	160
7.68	65	19.25	163
8.03	68	22.68	192
8.15	69	23.62	200
8.27	70	37.20	315
10.87	92	41.81	354
11.34	96	44.29	375
11.46	97	49.72	421
11.69	99		

5 mm HTD® Pitch

Pitch Length	No. of Teeth	Pitch Length	No. of Teeth
36.42	185	70.47	358
41.34	210	70.87	360
44.29	225	74.61	379
50.00	254	78.74	400
55.91	284	99.41	505
62.80	319		

E*P*S TIMING BELTS

.080 Pitch, 1/8", 3/16", 1/4" Wide For Economy ■ Power ■ Speed

MXL

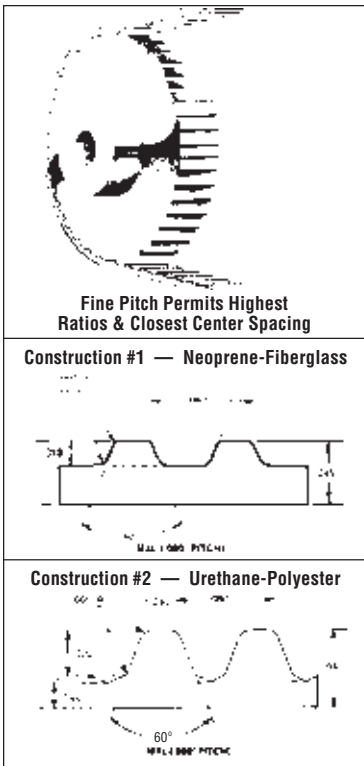

Pitch Length	No. of Grooves	Neoprene Belts			Urethane Belts*		
		1/8" Wide Belts Part No.	3/16" Wide Belts Part No.	1/4" Wide Belts Part No.	1/8" Wide Belts Part No.	3/16 Wide Belts Part No.	1/4" Wide Belts Part No.
3.60	45	EPS0045A125N	EPS0045A187N	EPS0045A250N	EPS0045A125U	EPS0045A187U	EPS0045A250U
4.00	50	EPS0050A125N	EPS0050A187N	EPS0050A250N	EPS0050A125U	EPS0050A187U	EPS0050A250U
4.40	55	EPS0055A125N	EPS0055A187N	EPS0055A250N	EPS0055A125U	EPS0055A187U	EPS0055A250U
4.80	60	EPS0060A125N	EPS0060A187N	EPS0060A250N	EPS0060A125U	EPS0060A187U	EPS0060A250U
5.60	70	EPS0070A125N	EPS0070A187N	EPS0070A250N	EPS0070A125U	EPS0070A187U	EPS0070A250U
6.40	80	EPS0080A125N	EPS0080A187N	EPS0080A250N	EPS0080A125U	EPS0080A187U	EPS0080A250U
6.80	85	EPS0085A125N	EPS0085A187N	EPS0085A250N	—	—	—
7.20	90	EPS0090A125N	EPS0090A187N	EPS0090A250N	EPS0090A125U	EPS0090A187U	EPS0090A250U
7.60	95	EPS0095A125N	EPS0095A187N	EPS0095A250N	EPS0095A125U	EPS0095A187U	EPS0095A250U
8.00	100	EPS0100A125N	EPS0100A187N	EPS0100A250N	EPS0100A125U	EPS0100A187U	EPS0100A250U
8.80	110	EPS0110A125N	EPS0110A187N	EPS0110A250N	EPS0110A125U	EPS0110A187U	EPS0110A250U
9.60	120	EPS0120A125N	EPS0120A187N	EPS0120A250N	EPS0120A125U	EPS0120A187U	EPS0120A250U
10.40	130	EPS0130A125N	EPS0130A187N	EPS0130A250N	—	—	—
11.20	140	EPS0140A125N	EPS0140A187N	EPS0140A250N	EPS0140A125U	EPS0140A187U	EPS0140A250U
12.00	150	EPS0150A125N	EPS0150A187N	EPS0150A250N	EPS0150A125U	EPS0150A187U	EPS0150A250U
13.20	165	EPS0165A125N	EPS0165A187N	EPS0165A250N	EPS0165A125U	EPS0165A187U	EPS0165A250U
14.00	175	EPS0175A125N	EPS0175A187N	EPS0175A250N	EPS0175A125U	EPS0175A187U	EPS0175A250U
15.20	190	EPS0190A125N	EPS0190A187N	EPS0190A250N	EPS0190A125U	EPS0190A187U	EPS0190A250U
16.00	200	EPS0200A125N	EPS0200A187N	EPS0200A250N	EPS0200A125U	EPS0200A187U	EPS0200A250U
16.80	210	EPS0210A125N	EPS0210A187N	EPS0210A250N	EPS0210A125U	EPS0210A187U	EPS0210A250U
18.00	225	EPS0225A125N	EPS0225A187N	EPS0225A250N	EPS0225A125U	EPS0225A187U	EPS0225A250U
20.00	250	EPS0250A125N	EPS0250A187N	EPS0250A250N	—	—	—
20.80	260	EPS0260A125N	EPS0260A187N	EPS0260A250N	EPS0260A125U	EPS0260A187U	EPS0260A250U
23.60	295	EPS0295A125N	EPS0295A187N	EPS0295A250N	EPS0295A125U	EPS0295A187U	EPS0295A250U
24.00	300	EPS0300A125N	EPS0300A187N	EPS0300A250N	EPS0300A125U	EPS0300A187U	EPS0300A250U
32.00	400	EPS0400A125N	EPS0400A187N	EPS0400A250N	EPS0400A125U	EPS0400A187U	EPS0400A250U

*For Urethane belts with Kevlar tensile member, add "K" to end of part number.

E*P*S TIMING PULLEYS

.080 Pitch, Molded, With Metal Hub or Sleeve. 1/8", to 1/4" Belt Width

MXL

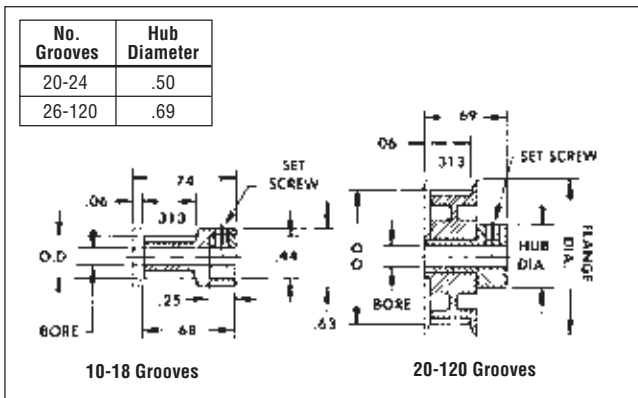

Material: Glass Filled Polycarbonate. Hub: Aluminum.
Special materials, bores, hub styles, sizes, etc., consult factory.

Bore	Set Screw
.125	#4-40
.187	#6-32
.250	#8-32
.313	#10-32

O.D. Tolerance	
No. Grooves	+ Tol
10-24	+0.03 -.001
25-70	+0.04 -.001
71-120	+0.05 -.001

Pulley Data					Single Flange	Double Flange
No. of Grooves	Pitch Dia.	Outside Dia.	Flange Dia. ±.03	Bore ±.0015 -.0000	Part Number	Part Number
10	.255	.235	.63	.125	PT010A04K04S	PT010A04K04T
12	.306	.286	.63	.125	PT012A04K04S	PT012A04K04T
14	.357	.337	.63	.125	PT014A04K04S	PT014A04K04T
15	.382	.362	.63	.187	PT015A06K04S	PT015A06K04T
16	.407	.387	.63	.250	PT016A08K04S	PT016A08K04T
18	.458	.438	.63	.250	PT018A08K04S	PT018A08K04T
20	.509	.489	.68	.187	PT020A06K04S	PT020A06K04T
21	.535	.515	.70	.187	PT021A06K04S	PT021A06K04T
22	.560	.540	.73	.187	PT022A06K04S	PT022A06K04T
24	.611	.591	.78	.187	PT024A06K04S	PT024A06K04T
26	.662	.642	.83	.250	PT026A08K04S	PT026A08K04T
28	.713	.693	.88	.250	PT028A08K04S	PT028A08K04T
30	.764	.744	.93	.250	PT030A08K04S	PT030A08K04T
32	.815	.795	.98	.250	PT032A08K04S	PT032A08K04T
36	.917	.897	1.09	.250	PT036A08K04S	PT036A08K04T
38	.968	.948	1.14	.250	PT038A08K04S	PT038A08K04T
40	1.019	.999	1.19	.250	PT040A08K04S	PT040A08K04T
42	1.070	1.050	1.24	.250	PT042A08K04S	PT042A08K04T
44	1.120	1.100	1.29	.250	PT044A08K04S	PT044A08K04T
46	1.171	1.151	1.34	.250	PT046A08K04S	PT046A08K04T
48	1.222	1.202	1.39	.250	PT048A08K04S	PT048A08K04T
50	1.273	1.253	1.44	.250	PT050A08K04S	PT050A08K04T
51	1.299	1.279	1.48	.250	PT051A08K04S	PT051A08K04T
60	1.528	1.508	1.70	.250	PT060A08K04S	PT060A08K04T
70	1.783	1.763	1.95	.313	PT070A10K04S	PT070A10K04T
72	1.833	1.813	2.00	.313	PT072A10K04S	PT072A10K04T
80	2.037	2.017	2.21	.313	PT080A10K04S	PT080A10K04T
90	2.292	2.272	2.46	.313	PT090A10K04S	PT090A10K04T
100	2.546	2.526	2.71	.313	PT100A10K04S	PT100A10K04T
110	2.801	2.781	2.97	.313	PT110A10K04S	PT110A10K04T
120	3.056	3.036	3.22	.313	PT120A10K04S	PT120A10K04T

E*P*S TIMING PULLEYS

MXL

.080 Pitch, 1/8" Belt Width, Double Flange

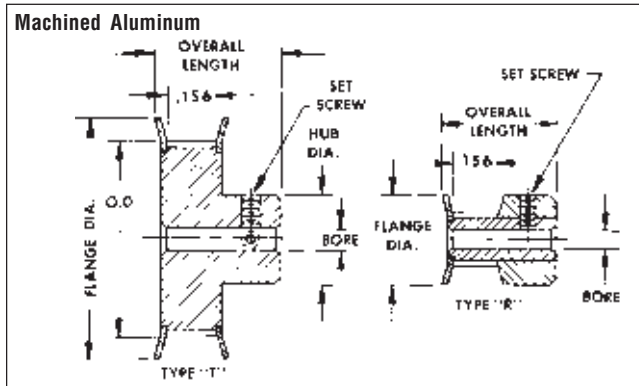

Material: Aluminum Alloy, Anodized.

Bore	Set Screw	Quantity
.125	#4-40	1
.188	#4-40	2*
.250	#6-40	2

O.D. Tolerance	
O.D.	Tol
Thru 1.000	+0.02
1.001-2.000	+0.03
2.001-4.000	+0.04

* 15 & 16 grooves, one set screw.

No. of Grooves	Type	Pitch Diameter	Outside Diameter	Flange Diameter ±.016	Overall Length ±.016	Hub Diameter ±.016	Bore +.001 -.000	Part Number
10	R	.255	.235	.425	.436	.425	.125	PT010A04L02R
11	R	.280	.260	.450	.436	.450	.125	PT011A04L02R
12	R	.306	.286	.480	.436	.480	.125	PT012A04L02R
14	R	.357	.337	.530	.436	.530	.125	PT014A04L02R
15	R	.382	.362	.555	.436	.555	.188	PT015A06L02R
16	R	.407	.387	.580	.436	.580	.188	PT016A06L02R
18	T*	.458	.438	.635	.484	.312	.188	PT018A06L02T
20	T*	.509	.486	.685	.484	.364	.188	PT020A06L02T
21	T*	.535	.515	.710	.484	.390	.188	PT021A06L02T
22	T*	.560	.540	.740	.484	.390	.188	PT022A06L02T
24	T	.611	.591	.790	.515	.442	.250	PT024A08L02T
28	T	.713	.693	.895	.515	.494	.250	PT028A08L02T
30	T	.764	.744	.945	.515	.546	.250	PT030A08L02T
32	T	.815	.795	1.000	.515	.598	.250	PT032A08L02T
36	T	.917	.897	1.105	.515	.676	.250	PT036A08L02T
40	T	1.019	.999	1.210	.531	.754	.250	PT040A08L02T
42	T	1.070	1.050	1.260	.531	.806	.250	PT042A08L02T
44	T	1.120	1.100	1.315	.531	.858	.250	PT044A08L02T
48	T	1.222	1.202	1.412	.531	.936	.250	PT048A08L02T
60	T	1.528	1.508	1.730	.531	1.222	.250	PT060A08L02T

Specials: Materials, bores, hub styles, integral bushings or bearings, widths, finishes, sizes, etc., consult factory.

* Type "R" hub style available, consult factory.

E*P*S TIMING PULLEYS

MXL

.080 Pitch, 1/4" Belt Width, Double Flange

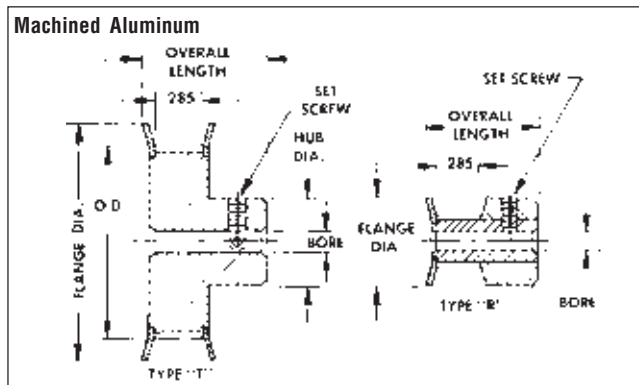

Material: Aluminum Alloy, Anodized.

Bore	Set Screw	Quantity
.125	#4-40	1
.188 (15-16G)	#6-40	1
.188	#6-40	2
.250 (24-28G)	#6-40	2
.250	#8-32	2
.312	#8-32	2
.375	#10-32	2

O.D. Tolerance	
O.D.	Tol
Thru 1.000	+0.02
1.001-2.000	+0.03
2.001-4.000	+0.04

No. of Grooves	Type	Pitch Diameter	Outside Diameter	Flange Diameter ±.016	Overall Length ±.016	Hub Diameter ±.016	Bore +.001 -.000	Part Number
10	R	.255	.235	.425	.565	.425	.125	PT010A04L04R
11	R	.280	.260	.450	.565	.450	.125	PT011A04L04R
12	R	.306	.286	.480	.565	.480	.125	PT012A04L04R
14	R	.357	.337	.530	.565	.530	.125	PT014A04L04R
15	R	.382	.362	.555	.565	.555	.188	PT015A06L04R
16	R	.407	.387	.580	.565	.580	.188	PT016A06L04R
18	T*	.458	.438	.635	.625	.312	.188	PT018A06L04T
20	T*	.509	.486	.685	.625	.364	.188	PT020A06L04T
21	T*	.535	.515	.710	.625	.390	.188	PT021A06L04T
22	T*	.560	.540	.740	.625	.390	.188	PT022A06L04T
24	T	.611	.591	.790	.687	.442	.250	PT024A08L04T
28	T	.713	.693	.895	.687	.494	.250	PT028A08L04T
30	T	.764	.744	.945	.687	.546	.250	PT030A08L04T
32	T	.815	.795	1.000	.687	.598	.250	PT032A08L04T
36	T	.917	.897	1.105	.687	.676	.250	PT036A08L04T
40	T	1.019	.999	1.210	.718	.754	.250	PT040A08L04T
42	T	1.070	1.050	1.260	.718	.806	.250	PT042A08L04T
44	T	1.120	1.100	1.315	.718	.858	.250	PT044A08L04T
48	T	1.222	1.202	1.412	.718	.936	.250	PT048A08L04T
60	T	1.528	1.508	1.730	.718	1.222	.250	PT060A08L04T
60	N	1.528	1.508	—	.750	1.148	.250	PT060A08L04N
72	N	1.833	1.813	—	.750	1.195	.250	PT072A08L04N
80	N	2.037	2.017	—	.750	1.500	.312	PT080A10L04N
90	N	2.292	2.272	—	.750	1.500	.312	PT090A10L04N
100	N	2.546	2.526	—	.750	1.500	.312	PT100A10L04N
120	N	3.056	3.036	—	.750	1.500	.375	PT120A12L04N

Special: Materials, bores, hub styles, integral bushings or bearings, widths, finishes, sizes, etc., consult factory.

*Type "R" hub style available. Consult factory.

Type "N", no flange.

E*P*S TIMING BELTS

40 D.P. (.0816 Pitch), 1/8", 1/4" Wide For Economy ■ Power ■ Speed ■ Urethane Belts*

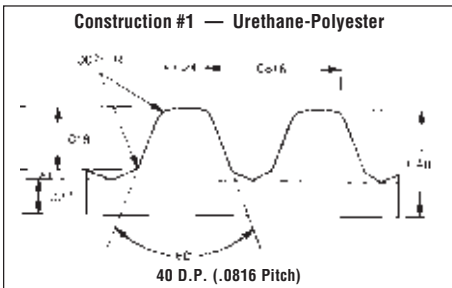

Pitch Length	No. of Grooves	1/8" Wide Belts Part No.	1/4" Wide Belts Part No.
2.693	33	EPS0033C125U	EPS0033C250U
3.590	44	EPS0044C125U	EPS0044C250U
3.917	48	EPS0048C125U	EPS0048C250U
4.162	51	EPS0051C125U	EPS0051C250U
4.488	55	EPS0055C125U	EPS0055C250U
4.651	57	EPS0057C125U	EPS0057C250U
4.896	60	EPS0060C125U	EPS0060C250U
4.978	61	EPS0061C125U	EPS0061C250U
5.304	65	EPS0065C125U	EPS0065C250U
5.630	69	EPS0069C125U	EPS0069C250U
5.875	72	EPS0072C125U	EPS0072C250U
6.120	75	EPS0075C125U	EPS0075C250U
6.202	76	EPS0076C125U	EPS0076C250U
6.528	80	EPS0080C125U	EPS0080C250U
6.610	81	EPS0081C125U	EPS0081C250U
6.854	84	EPS0084C125U	EPS0084C250U
6.936	85	EPS0085C125U	EPS0085C250U
7.262	89	EPS0089C125U	EPS0089C250U
7.344	90	EPS0090C125U	EPS0090C250U
7.752	95	EPS0095C125U	EPS0095C250U
7.997	98	EPS0098C125U	EPS0098C250U
8.160	100	EPS0100C125U	EPS0100C250U
8.323	102	EPS0102C125U	EPS0102C250U
8.976	110	EPS0110C125U	EPS0110C250U
9.466	116	EPS0116C125U	EPS0116C250U
9.629	118	EPS0118C125U	EPS0118C250U
9.710	119	EPS0119C125U	EPS0119C250U
9.792	120	EPS0120C125U	EPS0120C250U
9.955	122	EPS0122C125U	EPS0122C250U
10.037	123	EPS0123C125U	EPS0123C250U

Pitch Length	No. of Grooves	1/8" Wide Belts Part No.	1/4" Wide Belts Part No.
10.608	130	EPS0130C125U	EPS0130C250U
11.342	139	EPS0139C125U	EPS0139C250U
11.669	143	EPS0143C125U	EPS0143C250U
11.750	144	EPS0144C125U	EPS0144C250U
12.158	149	EPS0149C125U	EPS0149C250U
12.485	153	EPS0153C125U	EPS0153C250U
12.566	154	EPS0154C125U	EPS0154C250U
13.056	160	EPS0160C125U	EPS0160C250U
13.219	162	EPS0162C125U	EPS0162C250U
14.525	178	EPS0178C125U	EPS0178C250U
14.688	180	EPS0180C125U	EPS0180C250U
15.667	192	EPS0192C125U	EPS0192C250U
15.749	193	EPS0193C125U	EPS0193C250U
16.973	208	EPS0208C125U	EPS0208C250U
17.136	210	EPS0210C125U	EPS0210C250U
17.462	214	EPS0214C125U	EPS0214C250U
18.768	230	EPS0230C125U	EPS0230C250U
19.176	235	EPS0235C125U	EPS0235C250U
19.992	245	EPS0245C125U	EPS0245C250U
20.971	257	EPS0257C125U	EPS0257C250U
21.053	258	EPS0258C125U	EPS0258C250U
21.542	264	EPS0264C125U	EPS0264C250U
22.440	275	EPS0275C125U	EPS0275C250U
22.930	281	EPS0281C125U	EPS0281C250U
24.072	295	EPS0295C125U	EPS0295C250U
24.480	300	EPS0300C125U	EPS0300C250U
26.438	324	EPS0324C125U	EPS0324C250U
27.744	340	EPS0340C125U	EPS0340C250U
30.110	369	EPS0369C125U	EPS0369C250U
31.987	392	EPS0392C125U	EPS0392C250U

* For urethane belts with Kevlar tensile member, add "K" to end of part number.

Note: 3/16" and 5/16" wide belts available on request.

E*P*S TIMING PULLEYS

40 D.P. (.0816 Pitch), Molded, With Metal Hub or Sleeve, 1/8" to 1/4" Belt Width

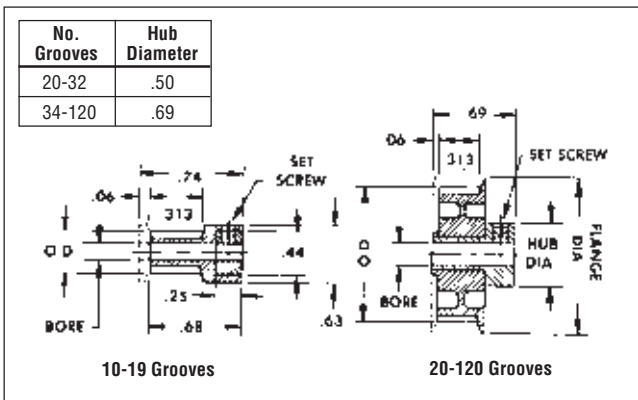

Material: Glass Filled Polycarbonate. Hub: Aluminum.
Special materials, bores, hub styles, sizes, etc., consult factory.

Bore	Set Screw
.125	#4-40
.187	#6-32
.250	#8-32
.313	#10-32

O.D. Tolerance	
No. Grooves	+ Tol
10-24	+ .003 - .001
25-70	+ .004 - .001
71-120	+ .005 - .001

Pulley Data					Single Flange	Double Flange
No. of Grooves	Pitch Dia.	Outside Dia.	Flange Dia. ±.03	Bore ±.0015 - .0000	Part Number	Part Number
10	.260	.246	.63	.125	PT010C04K04S	PT010C04K04T
14	.364	.350	.63	.125	PT014C04K04S	PT014C04K04T
15	.390	.376	.63	.187	PT015C06K04S	PT015C06K04T
16	.416	.402	.63	.250	PT016C08K04S	PT016C08K04T
18	.468	.454	.63	.250	PT018C08K04S	PT018C08K04T
19	.494	.480	.63	.250	PT019C08K04S	PT019C08K04T
20	.520	.506	.697	.187	PT020C06K04S	PT020C06K04T
22	.572	.558	.750	.187	PT022C06K04S	PT022C06K04T
24	.624	.610	.800	.187	PT024C06K04S	PT024C06K04T
25	.650	.636	.834	.250	PT025C08K04S	PT025C08K04T
26	.676	.662	.860	.250	PT026C08K04S	PT026C08K04T
28	.728	.714	.905	.250	PT028C08K04S	PT028C08K04T
29	.754	.740	.926	.250	PT029C08K04S	PT029C08K04T
30	.780	.766	.952	.250	PT030C08K04S	PT030C08K04T
32	.832	.818	1.005	.250	PT032C08K04S	PT032C08K04T
34	.884	.870	1.025	.250	PT034C08K04S	PT034C08K04T
36	.936	.922	1.107	.250	PT036C08K04S	PT036C08K04T
38	.988	.974	1.159	.250	PT038C08K04S	PT038C08K04T
40	1.040	1.026	1.212	.250	PT040C08K04S	PT040C08K04T
42	1.092	1.078	1.266	.250	PT042C08K04S	PT042C08K04T
44	1.144	1.130	1.315	.250	PT044C08K04S	PT044C08K04T
46	1.196	1.182	1.370	.250	PT046C08K04S	PT046C08K04T
48	1.248	1.234	1.442	.250	PT048C08K04S	PT048C08K04T
50	1.300	1.286	1.471	.250	PT050C08K04S	PT050C08K04T
51	1.326	1.312	1.497	.250	PT051C08K04S	PT051C08K04T
54	1.404	1.390	1.575	.250	PT054C08K04S	PT054C08K04T
60	1.560	1.546	1.723	.250	PT060C08K04S	PT060C08K04T
64	1.664	1.650	1.824	.250	PT064C08K04S	PT064C08K04T
70	1.820	1.806	1.991	.250	PT070C08K04S	PT070C08K04T
72	1.872	1.858	2.035	.313	PT072C10K04S	PT072C10K04T
75	1.950	1.936	2.121	.313	PT075C10K04S	PT075C10K04T
80	2.080	2.066	2.251	.313	PT080C10K04S	PT080C10K04T
84	2.184	2.170	2.355	.313	PT084C10K04S	PT084C10K04T
90	2.340	2.326	2.511	.313	PT090C10K04S	PT090C10K04T
98	2.548	2.534	2.719	.313	PT098C10K04S	PT098C10K04T
100	2.600	2.586	2.771	.313	PT100C10K04S	PT100C10K04T
102	2.652	2.638	2.823	.313	PT102C10K04S	PT102C10K04T
110	2.860	2.846	3.031	.313	PT110C10K04S	PT110C10K04T
120	3.120	3.106	3.365	.313	PT120C10K04S	PT120C10K04T

E*P*S TIMING PULLEYS

40 D.P. (.0816 Pitch), 1/8" and 3/16" Belt Width, Double Flange

Machined Aluminum

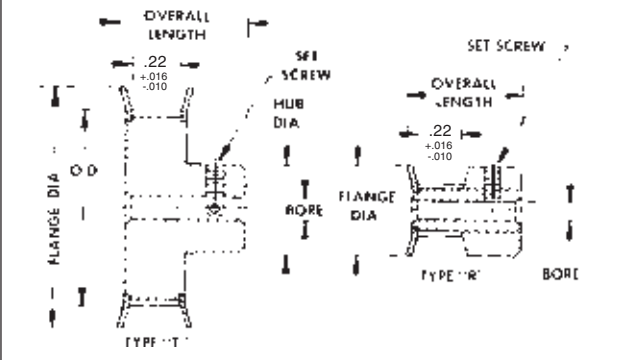

Material: Aluminum Alloy, Anodized.

Bore	Set Screw	Quantity
.125	#4-40	1
.188	#6-40	2*
.250	#6-40	2

* 15 & 16 grooves, one set screw.

No. of Grooves	Type	Pitch Diameter	Outside Diameter -.003	Flange Diameter ±.016	Overall Length ±.016	Hub Diameter ±.016	Bore +.001 -.000	Part Number
10	R	.260	.246	.425	.500	.425	.125	PT010C04L02R
11	R	.286	.272	.450	.500	.450	.125	PT011C04L02R
12	R	.312	.298	.480	.500	.480	.125	PT012C04L02R
14	R	.364	.350	.530	.500	.530	.125	PT014C04L02R
15	R	.390	.376	.555	.500	.555	.188	PT015C06L02R
16	R	.416	.402	.580	.500	.580	.188	PT016C06L02R
18	T*	.468	.454	.635	.563	.312	.188	PT018C06L02T
20	T*	.520	.506	.685	.563	.364	.188	PT020C06L02T
21	T*	.546	.532	.710	.563	.390	.188	PT021C06L02T
22	T*	.572	.558	.740	.563	.390	.188	PT022C06L02T
24	T	.624	.610	.790	.625	.442	.250	PT024C08L02T
28	T	.728	.714	.895	.625	.494	.250	PT028C08L02T
30	T	.780	.766	.945	.625	.546	.250	PT030C08L02T
32	T	.832	.818	1.000	.625	.598	.250	PT032C08L02T
36	T	.936	.922	1.105	.625	.676	.250	PT036C08L02T
40	T	1.040	1.026	1.210	.656	.754	.250	PT040C08L02T
42	T	1.092	1.078	1.260	.656	.806	.250	PT042C08L02T
44	T	1.144	1.130	1.315	.656	.858	.250	PT044C08L02T
48	T	1.248	1.234	1.420	.656	.936	.250	PT048C08L02T
60	T	1.560	1.546	1.730	.656	1.222	.250	PT060C08L02T

Specials: Materials, bores, hub styles, integral bushings or bearings, widths, finishes, sizes, etc., consult factory.

* Type "R" hub style available, consult factory.

E*P*S TIMING PULLEYS

40 D.P. (.0816 Pitch), 1/4" and 5/16" Belt Width, Double Flange

Machined Aluminum

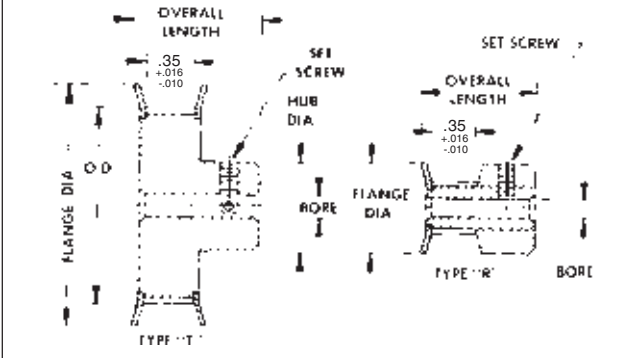

Material: Aluminum Alloy, Anodized.

Bore	Set Screw	Quantity
.125	#4-40	1
.188 (15-16G)	#6-40	1
.188	#6-40	2
.250 (24-28G)	#6-40	2
.250	#8-32	2
.312	#8-32	2
.375	#10-32	2

No. of Grooves	Type	Pitch Diameter	Outside Diameter -.003	Flange Diameter ±.016	Overall Length ±.016	Hub Diameter ±.016	Bore +.001 -.000	Part Number
10	R	.260	.246	.425	.625	.425	.125	PT010C04L04R
11	R	.286	.272	.450	.625	.450	.125	PT011C04L04R
12	R	.312	.298	.480	.625	.480	.125	PT012C04L04R
14	R	.364	.350	.530	.625	.530	.125	PT014C04L04R
15	R	.390	.376	.555	.625	.555	.188	PT015C06L04R
16	R	.416	.402	.580	.625	.580	.188	PT016C06L04R
18	T*	.468	.454	.635	.688	.312	.188	PT018C06L04T
20	T*	.520	.506	.685	.688	.364	.188	PT020C06L04T
21	T*	.546	.532	.710	.688	.390	.188	PT021C06L04T
22	T*	.572	.558	.740	.688	.390	.188	PT022C06L04T
24	T	.624	.610	.790	.750	.442	.250	PT024C08L04T
28	T	.728	.714	.895	.750	.494	.250	PT028C08L04T
30	T	.780	.766	.945	.750	.546	.250	PT030C08L04T
32	T	.832	.818	1.000	.750	.598	.250	PT032C08L04T
36	T	.936	.922	1.105	.750	.676	.250	PT036C08L04T
40	T	1.040	1.026	1.210	.781	.754	.250	PT040C08L04T
42	T	1.092	1.078	1.260	.781	.806	.250	PT042C08L04T
44	T	1.144	1.130	1.315	.781	.858	.250	PT044C08L04T
48	T	1.248	1.234	1.420	.781	.936	.250	PT048C08L04T
60	T	1.560	1.546	1.730	.781	1.222	.250	PT060C08L04T
60	N	1.560	1.546	—	.875	1.184	.250	PT060C08L04N
72	N	1.872	1.858	—	.875	1.195	.250	PT072C08L04N
80	N	2.080	2.066	—	.875	1.500	.250	PT080C08L04N
90	N	2.340	2.326	—	.875	1.500	.250	PT090C08L04N
100	N	2.600	2.586	—	.875	1.500	.312	PT100C10L04N
120	N	3.120	3.106	—	.875	1.500	.375	PT120C12L04N

Special: Materials, bores, hub styles, integral bushings or bearings, widths, finishes, sizes, etc., consult factory.

*Type "R" hub style available. Consult factory. Type "N", no flange.

Note: Pulleys over 60 grooves are without flanges.

E*P*S TIMING BELTS

1/5" (.200) Pitch, 1/4", 3/8" Wide For Economy ■ Power ■ Speed

XL

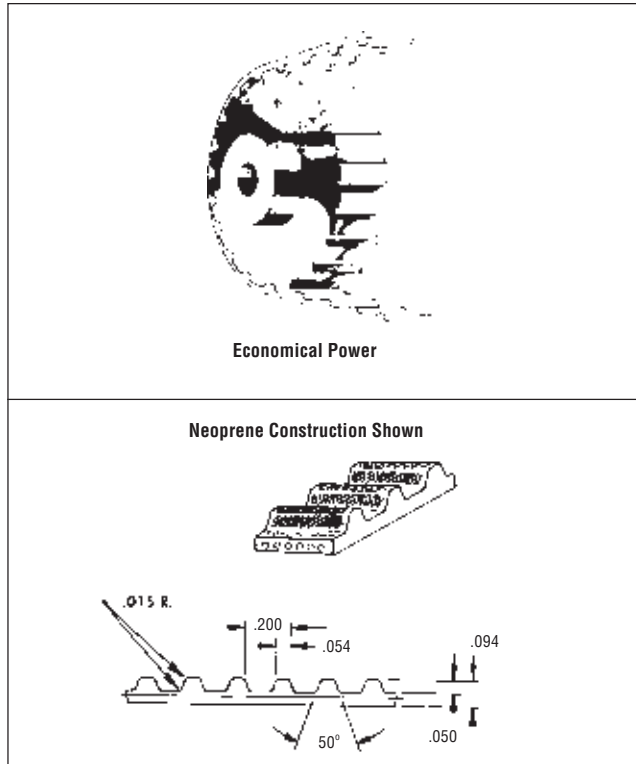

Pitch Length	No. of Grooves	Neoprene Belts		Urethane Belts*	
		1/4" Wide Belts Part No.	3/8" Wide Belts Part No.	1/4" Wide Belts Part No.	3/8" Wide Belts Part No.
5.00	25	EPS0025D250N	EPS0025D375N	—	—
6.00	30	EPS0030D250N	EPS0030D375N	EPS0030D250U	EPS0030D375U
7.00	35	EPS0035D250N	EPS0035D375N	EPS0035D250U	EPS0035D375U
8.00	40	EPS0040D250N	EPS0040D375N	EPS0040D250U	EPS0040D375U
9.00	45	EPS0045D250N	EPS0045D375N	EPS0045D250U	EPS0045D375U
10.00	50	EPS0050D250N	EPS0050D375N	EPS0050D250U	EPS0050D375U
11.00	55	EPS0055D250N	EPS0055D375N	EPS0055D250U	EPS0055D375U
12.00	60	EPS0060D250N	EPS0060D375N	EPS0060D250U	EPS0060D375U
13.00	65	EPS0065D250N	EPS0065D375N	EPS0065D250U	EPS0065D375U
14.00	70	EPS0070D250N	EPS0070D375N	EPS0070D250U	EPS0070D375U
15.00	75	EPS0075D250N	EPS0075D375N	EPS0075D250U	EPS0075D375U
16.00	80	EPS0080D250N	EPS0080D375N	EPS0080D250U	EPS0080D375U
17.00	85	EPS0085D250N	EPS0085D375N	EPS0085D250U	EPS0085D375U
18.00	90	EPS0090D250N	EPS0090D375N	EPS0090D250U	EPS0090D375U
19.00	95	EPS0095D250N	EPS0095D375N	EPS0095D250U	EPS0095D375U
20.00	100	EPS0100D250N	EPS0100D375N	EPS0100D250U	EPS0100D375U
21.00	105	EPS0105D250N	EPS0105D375N	EPS0105D250U	EPS0105D375U
22.00	110	EPS0110D250N	EPS0110D375N	EPS0110D250U	EPS0110D375U
23.00	115	EPS0115D250N	EPS0115D375N	EPS0115D250U	EPS0115D375U
24.00	120	EPS0120D250N	EPS0120D375N	EPS0120D250U	EPS0120D375U
25.00	125	EPS0125D250N	EPS0125D375N	EPS0125D250U	EPS0125D375U
26.00	130	EPS0130D250N	EPS0130D375N	EPS0130D250U	EPS0130D375U
28.00	140	EPS0140D250N	EPS0140D375N	—	—
29.00	145	EPS0145D250N	EPS0145D375N	EPS0145D250U	EPS0145D375U
30.00	150	EPS0150D250N	EPS0150D375N	—	—
31.00	155	EPS0155D250N	EPS0155D375N	—	—
33.00	165	EPS0165D250N	EPS0165D375N	—	—

*For Urethane belts with Kevlar tensile member, add "K" to end of part number.

E*P*S TIMING PULLEYS

1/5" (.200) Pitch, 3/8" Belt Width, No Flange

XL

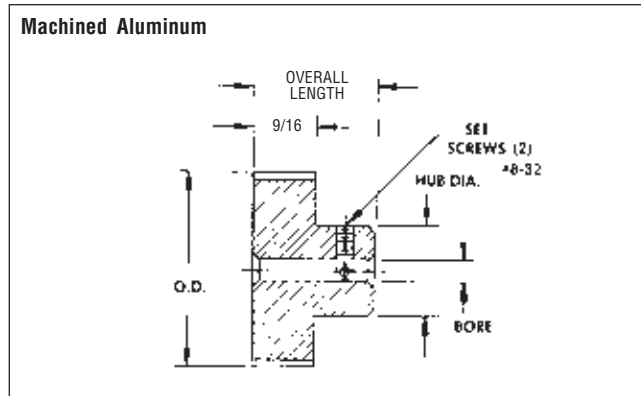

Material: Aluminum Alloy, Anodized

No. of Grooves	Pitch Diameter	Outside Diameter	Overall Length ±.016	Hub Diameter ±.016	Standard Bore +.001 - .000	Standard Bore Part Number
10	.637	.617	.813	.438	.188	PT010D06L06N
11	.700	.680	.813	.500	.188	PT011D06L06N
12	.764	.744	.813	.563	.188	PT012D06L06N
14	.891	.871	.813	.625	.250	PT014D08L06N
15	.955	.935	.875	.688	.250	PT015D08L06N
16	1.019	.999	.875	.750	.250	PT016D08L06N
17	1.082	1.062	.875	.813	.250	PT017D08L06N
18	1.146	1.126	.875	.875	.250	PT018D08L06N
19	1.210	1.190	.875	.875	.250	PT019D08L06N
20	1.273	1.253	.938	.938	.250	PT020D08L06N
21	1.337	1.317	.938	1.000	.250	PT021D08L06N
22	1.401	1.381	.938	1.063	.250	PT022D08L06N
23	1.464	1.444	.938	1.125	.250	PT023D08L06N
24	1.528	1.508	.938	1.188	.250	PT024D08L06N
25	1.592	1.572	.938	1.250	.250	PT025D08L06N
27	1.719	1.699	.938	1.250	.313	PT027D10L06N
28	1.783	1.763	.938	1.250	.250	PT028D08L06N
29	1.846	1.826	.938	1.313	.313	PT029D10L06N
30	1.910	1.890	.938	1.375	.250	PT030D08L06N
32	2.037	2.017	1.000	1.500	.313	PT032D10L06N
36	2.292	2.272	1.000	1.500	.313	PT036D10L06N

Bore	Set Screw	Quantity
.188	#6-40	1
.250	#8-32	2
.313	#8-32	2

O.D. Tolerance	
O.D.	Tol
Thru 1.000	+.002
1.001-2.000	+.003
2.001-4.000	+.004

Specials: Materials, bores, hub styles, integral bushings or bearings, widths, finishes, sizes, etc., consult factory.

E*P*S TIMING PULLEYS

XL

1/5" (.200) Pitch, 3/8" Belt Width, Single & Double Flange

No. Grooves	Hub Diameter
10-13	11/16
14-19	3/4
20 & Up	7/8

Molded, With Metal Hub Or Sleeve.

Single Flange Double Flange

Material: Glass Filled Polycarbonate.

Bore	Set Screw	O.D. Tolerance	
		No. Grooves	+ Tol
.187	#6-32	10 - 28	+ .003
.250	#8-32		- .001
.313	#10-32	29 - 58	+ .004
			- .001
		60 - 72	+ .005
			- .001

Specials: Materials, bores, hub styles, integral bushings or bearings, widths, finishes, sizes, etc., consult factory.

Pulley Data					Single Flange	Double Flange
No. of Grooves	Pitch Dia.	Outside Dia.	Flange Dia. ±.030	Bore +.0015 -.0000	Part Number	Part Number
10	.637	.617	.87	.187	PT010D06K06S	PT010D06K06T
11	.700	.680	.93	.187	PT011D06K06S	PT011D06K06T
12	.764	.744	.99	.187	PT012D06K06S	PT012D06K06T
13	.828	.808	1.06	.187	PT013D06K06S	PT013D06K06T
14	.891	.871	1.12	.250	PT014D08K06S	PT014D08K06T
15	.955	.935	1.19	.250	PT015D08K06S	PT015D08K06T
16	1.019	.999	1.24	.250	PT016D08K06S	PT016D08K06T
17	1.082	1.062	1.31	.250	PT017D08K06S	PT017D08K06T
18	1.146	1.126	1.39	.250	PT018D08K06S	PT018D08K06T
19	1.210	1.190	1.44	.250	PT019D08K06S	PT019D08K06T
20	1.273	1.253	1.51	.250	PT020D08K06S	PT020D08K06T
21	1.337	1.317	1.57	.250	PT021D08K06S	PT021D08K06T
22	1.401	1.381	1.63	.250	PT022D08K06S	PT022D08K06T
23	1.464	1.444	1.69	.250	PT023D08K06S	PT023D08K06T
24	1.528	1.508	1.76	.250	PT024D08K06S	PT024D08K06T
25	1.592	1.572	1.82	.250	PT025D08K06S	PT025D08K06T
26	1.655	1.635	1.89	.250	PT026D08K06S	PT026D08K06T
27	1.719	1.699	1.95	.250	PT027D08K06S	PT027D08K06T
28	1.783	1.763	2.02	.250	PT028D08K06S	PT028D08K06T
29	1.846	1.826	2.08	.250	PT029D08K06S	PT029D08K06T
30	1.910	1.890	2.14	.313	PT030D10K06S	PT030D10K06T
31*	1.974	1.954	2.20	.313	PT031D10K06S	PT031D10K06T
32*	2.037	2.017	2.27	.313	PT032D10K06S	PT032D10K06T
34*	2.165	2.145	2.40	.313	PT034D10K06S	PT034D10K06T
35*	2.228	2.208	2.46	.313	PT035D10K06S	PT035D10K06T
36*	2.292	2.272	2.53	.313	PT036D10K06S	PT036D10K06T
37*	2.355	2.335	2.59	.313	PT037D10K06S	PT037D10K06T
39*	2.482	2.462	2.71	.313	PT039D10K06S	PT039D10K06T
40*	2.546	2.526	2.78	.313	PT040D10K06S	PT040D10K06T
42*	2.674	2.654	2.92	.313	PT042D10K06S	PT042D10K06T
44*	2.801	2.781	3.04	.313	PT044D10K06S	PT044D10K06T
48*	3.056	3.036	3.29	.313	PT048D10K06S	PT048D10K06T

* Overall length 7/8"

E*P*S TIMING PULLEYS

XL

1/5" (.200) Pitch, 3/8" Belt Width, Single & Double Flange

No. Grooves	Hub Diameter
10-13	11/16
14-19	3/4
20 & Up	7/8

Molded, With Molded Hubs.

Single Flange* Double Flange

* 60 & 72 Groove Pulleys Have No Flange
Overall length of 7/8"

Material: Glass Filled Polycarbonate.

O.D. Tolerance	
No. Grooves	+ Tol
10 - 28	+ .003
29 - 58	+ .004
60 - 72	+ .005

Specials: Materials, bores, hub styles, integral bushings or bearings, widths, finishes, sizes, etc., consult factory.

Pulley Data					Single Flange	Double Flange
No. of Grooves	Pitch Dia.	Outside Dia.	Flange Dia. ±.030	Bore +.002 -.000	Part Number	Part Number
10	.637	.617	.87	.187	PT010D06J06S	PT010D06J06T
11	.700	.680	.93	.187	PT011D06J06S	PT011D06J06T
12	.764	.744	.99	.187	PT012D06J06S	PT012D06J06T
13	.828	.808	1.06	.187	PT013D06J06S	PT013D06J06T
14	.891	.871	1.12	.250	PT014D08J06S	PT014D08J06T
15	.955	.935	1.19	.250	PT015D08J06S	PT015D08J06T
16	1.019	.999	1.24	.250	PT016D08J06S	PT016D08J06T
17	1.082	1.062	1.31	.250	PT017D08J06S	PT017D08J06T
18	1.146	1.126	1.39	.250	PT018D08J06S	PT018D08J06T
19	1.210	1.190	1.44	.250	PT019D08J06S	PT019D08J06T
20	1.273	1.253	1.51	.250	PT020D08J06S	PT020D08J06T
21	1.337	1.317	1.57	.250	PT021D08J06S	PT021D08J06T
22	1.401	1.381	1.63	.250	PT022D08J06S	PT022D08J06T
23	1.464	1.444	1.69	.250	PT023D08J06S	PT023D08J06T
24	1.528	1.508	1.76	.250	PT024D08J06S	PT024D08J06T
25	1.592	1.572	1.82	.250	PT025D08J06S	PT025D08J06T
26	1.655	1.635	1.89	.250	PT026D08J06S	PT026D08J06T
27	1.719	1.699	1.95	.250	PT027D08J06S	PT027D08J06T
28	1.783	1.763	2.02	.250	PT028D08J06S	PT028D08J06T
29	1.846	1.826	2.08	.250	PT029D08J06S	PT029D08J06T
30	1.910	1.890	2.14	.313	PT030D10J06S	PT030D10J06T
31	1.974	1.954	2.20	.313	PT031D10J06S	PT031D10J06T
32	2.037	2.017	2.27	.313	PT032D10J06S	PT032D10J06T
34	2.165	2.145	2.40	.313	PT034D10J06S	PT034D10J06T
35	2.228	2.208	2.46	.313	PT035D10J06S	PT035D10J06T
36	2.292	2.272	2.53	.313	PT036D10J06S	PT036D10J06T
37	2.355	2.335	2.59	.313	PT037D10J06S	PT037D10J06T
39	2.482	2.462	2.71	.313	PT039D10J06S	PT039D10J06T
40	2.546	2.526	2.78	.313	PT040D10J06S	PT040D10J06T
42	2.674	2.654	2.92	.313	PT042D10J06S	PT042D10J06T
44	2.801	2.781	3.04	.313	PT044D10J06S	PT044D10J06T
48	3.056	3.036	3.29	.313	PT048D10J06S	PT048D10J06T
58	3.692	3.672	3.92	.375	PT058D12J06S	—
60*	3.820	3.800	4.05	.375	PT060D12J06N	—
72*	4.584	4.564	4.81	.375	PT072D12J06N	—

E*P*S TIMING PULLEYS

1/5" (.200) Pitch, 1/4" Belt Width, Double Flange

XL

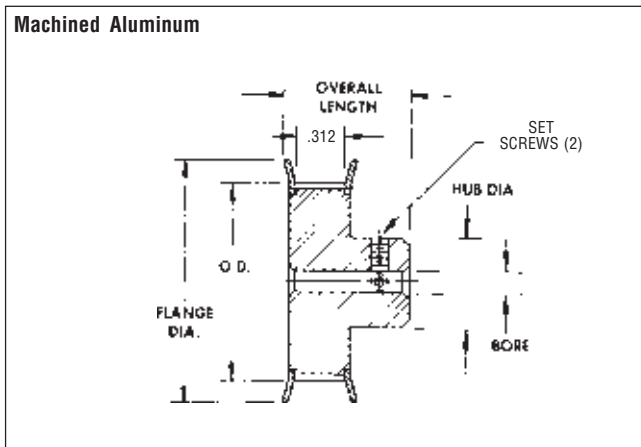

No. of Grooves	Pitch Diameter	Outside Diameter	Flange Diameter ±.016	Overall Length ±.016	Hub Diameter ±.016	Standard Bore +.001 -.000	Bore Part Number
10	.637	.617	.875	.688	.375	.188	PT010D06L04T
11	.700	.680	.938	.688	.438	.188	PT011D06L04T
12	.764	.744	1.000	.688	.500	.188	PT012D06L04T
13	.828	.808	1.063	.688	.563	.250	PT013D08L04T
14	.891	.871	1.095	.688	.563	.250	PT014D08L04T
15	.955	.935	1.188	.688	.625	.250	PT015D08L04T
16	1.019	.999	1.250	.688	.688	.250	PT016D08L04T
18	1.146	1.126	1.375	.688	.813	.250	PT018D08L04T
20	1.273	1.253	1.500	.750	.938	.250	PT020D08L04T
21	1.337	1.317	1.563	.750	1.000	.250	PT021D08L04T
22	1.401	1.381	1.625	.750	1.000	.250	PT022D08L04T
24	1.528	1.508	1.750	.781	1.063	.250	PT024D08L04T
26	1.655	1.635	1.875	.781	1.188	.250	PT026D08L04T
28	1.783	1.763	2.000	.781	1.188	.250	PT028D08L04T
30	1.910	1.890	2.125	.781	1.313	.250	PT030D08L04T

Material: Aluminum Alloy, Anodized.

Specials: Materials, bores, hub styles, integral bushings or bearings, widths, finishes, sizes, etc., consult factory.

Bore	Set Screw	Quantity
.188	#6-40	2
.250	#8-32	2

O.D. Tolerance	
O.D.	Tol
Thru 1.000	+.002
1.001-2.000	+.003
2.001-4.000	+.004

E*P*S TIMING PULLEYS

1/5" (.200) Pitch, 3/8" Belt Width, Double Flange

XL

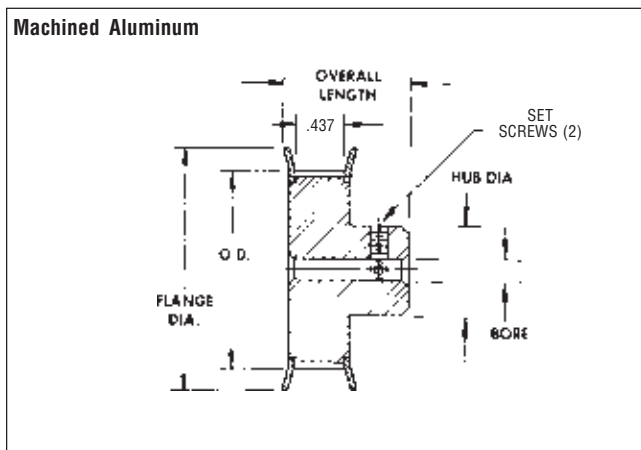

No. of Grooves	Pitch Diameter	Outside Diameter	Flange Diameter ±.016	Overall Length ±.016	Hub Diameter ±.016	Standard Bore +.001 -.000	Bore Part Number
10	.637	.617	.875	.813	.438	.188	PT010D06L06T
11	.700	.680	.938	.813	.500	.188	PT011D06L06T
12	.764	.744	1.000	.813	.500	.188	PT012D06L06T
13	.828	.808	1.063	.813	.563	.250	PT013D08L06T
14	.891	.871	1.095	.813	.563	.250	PT014D08L06T
15	.955	.935	1.188	.813	.625	.250	PT015D08L06T
16	1.019	.999	1.250	.813	.688	.250	PT016D08L06T
17	1.082	1.062	1.313	.813	.750	.250	PT017D08L06T
18	1.146	1.126	1.375	.813	.813	.250	PT018D08L06T
19	1.210	1.190	1.438	.813	.875	.250	PT019D08L06T
20	1.273	1.253	1.500	.875	.938	.250	PT020D08L06T
21	1.337	1.317	1.563	.875	1.000	.250	PT021D08L06T
22	1.401	1.381	1.625	.875	1.000	.250	PT022D08L06T
23	1.464	1.444	1.688	.875	1.063	.250	PT023D08L06T
24	1.528	1.508	1.750	.906	1.063	.250	PT024D08L06T
25	1.592	1.572	1.813	.906	1.095	.250	PT025D08L06T
26	1.655	1.635	1.875	.906	1.188	.250	PT026D08L06T
28	1.783	1.763	2.000	.906	1.188	.250	PT028D08L06T
30	1.910	1.890	2.125	.906	1.313	.250	PT030D08L06T
32	2.037	2.017	2.250	.906	1.438	.313	PT032D10L06T

Material: Aluminum Alloy, Anodized.

Specials: Materials, bores, hub styles, integral bushings or bearings, widths, finishes, sizes, etc., consult factory.

Bore	Set Screw	Quantity
.188	#6-40	2
.250	#8-32	2
.313	#8-32	2

O.D. Tolerance	
O.D.	Tol
Thru 1.000	+.002
1.001-2.000	+.003
2.001-4.000	+.004

E*P*S TIMING BELTS

3/8" Pitch, 1/2" Wide For Economy ■ Power ■ Speed

L

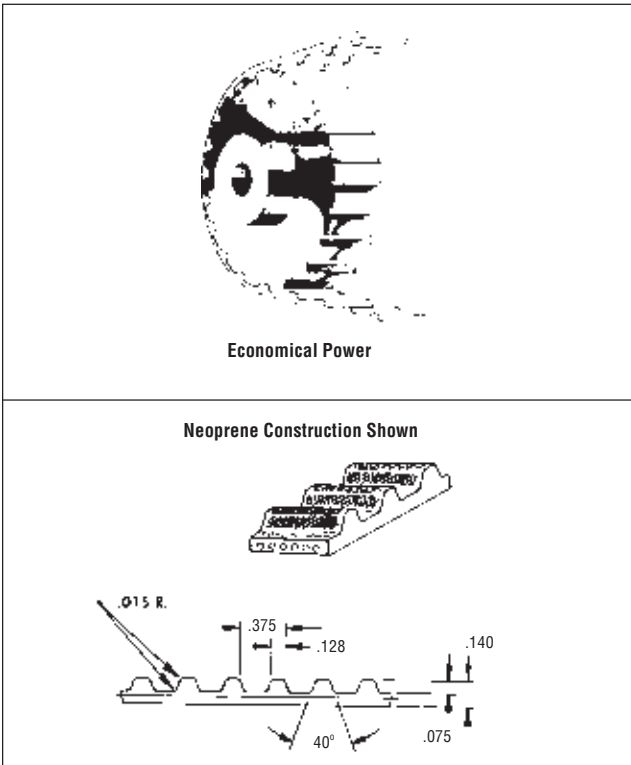

Pitch Length	Number of Teeth	1/2" Wide Part Number
12.375	33	EPS0033J500N
13.500	36	EPS0036J500N
15.000	40	EPS0040J500N
16.500	44	EPS0044J500N
18.750	50	EPS0050J500N
19.500	52	EPS0052J500N
21.000	56	EPS0056J500N
22.500	60	EPS0060J500N
24.000	64	EPS0064J500N
25.500	68	EPS0068J500N
27.000	72	EPS0072J500N
28.500	76	EPS0076J500N
30.000	80	EPS0080J500N
31.500	84	EPS0084J500N
32.250	86	EPS0086J500N
34.500	92	EPS0092J500N
36.700	98	EPS0098J500N
39.000	104	EPS0104J500N
42.000	112	EPS0112J500N
45.000	120	EPS0120J500N

E*P*S TIMING PULLEYS

3/8" Pitch, 1/2" Belt Width, Double Flange

L

Machined Aluminum

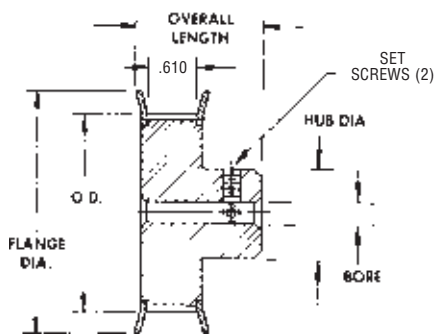

Material: 10-24 Grooves — Aluminum Alloy, Anodized.
26-32 Grooves — Cast Iron. No hole for set screw on Cast Iron Pulleys.

No. of Grooves	Pitch Diameter	Outside Diameter	Flange Diameter ±.016	Overall Length ±.016	Hub Diameter ±.016	Standard Bore +.001 -.000	Standard Bore Part Number
10	1.194	1.164	1.438	1.125	.813	.375	PT010J12L08T
11	1.313	1.283	1.531	1.125	.938	.375	PT011J12L08T
12	1.432	1.402	1.656	1.250	1.063	.375	PT012J12L08T
13	1.552	1.522	1.781	1.250	1.094	.375	PT013J12L08T
14	1.671	1.641	1.906	1.250	1.125	.375	PT014J12L08T
15	1.790	1.760	2.031	1.250	1.250	.375	PT015J12L08T
16	1.910	1.880	2.125	1.375	1.438	.500	PT016J16L08T
17	2.029	1.999	2.250	1.375	1.500	.500	PT017J16L08T
18	2.149	2.119	2.375	1.375	1.563	.500	PT018J16L08T
19	2.268	2.238	2.500	1.375	1.625	.500	PT019J16L08T
20	2.387	2.357	2.625	1.375	1.688	.500	PT020J16L08T
21	2.507	2.477	2.750	1.438	1.875	.500	PT021J16L08T
22	2.626	2.596	2.875	1.500	2.000	.500	PT022J16L08T
24	2.865	2.835	3.094	1.500	2.250	.500	PT024J16L08T
26	3.104	3.074	3.375	1.500	2.250	.500	PT026J16L08T
28	3.342	3.312	3.625	1.500	2.250	.500	PT028J16L08T
30	3.581	3.551	3.813	1.500	2.250	.500	PT030J16L08T
32	3.820	3.790	4.063	1.625	2.563	.500	PT032J16L08T

*Alternate Bores Available, Consult Factory.
Special: Materials, bores, hub styles, integral bushings or bearings, widths, finishes, sizes, etc., consult factory.

Bore	Set Screw	O.D. Tolerance	
		O.D.	Tol
3/8	#10-32	1.001-2.000	+ .003
1/2	#1/4-20	2.001-4.000	+ .004

E*P*S HTD® TIMING BELTS

3mm HTD® Pitch, 6mm & 9mm Wide For Economy ▪ Power ▪ Speed

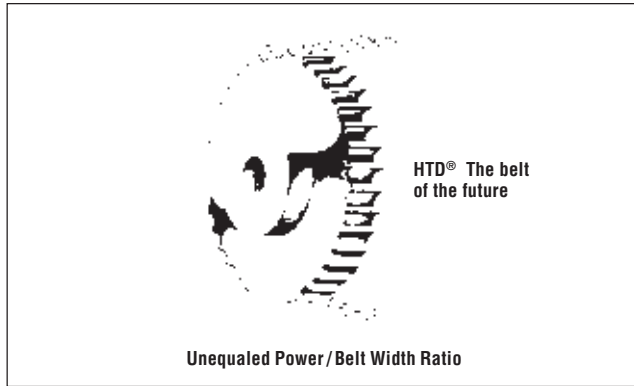

Material: Neoprene with nylon wear surface & helically-wound fiberglass reinforcing

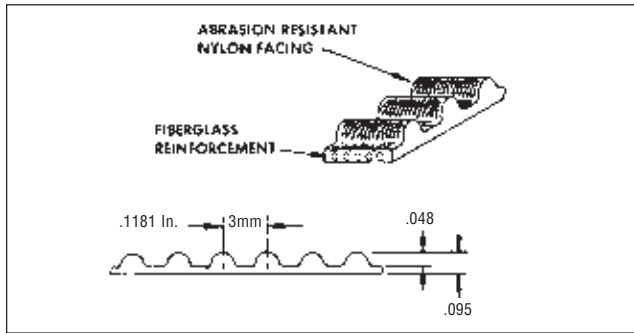

Pitch Length		Number of Grooves	6mm Wide Belts Part Number	9mm Wide Belts Part Number
Inch	mm			
5.91	150	50	EPS0050F06mN	EPS0050F09mN
6.26	159	53	EPS0053F06mN	EPS0053F09mN
6.61	168	56	EPS0056F06mN	EPS0056F09mN
6.97	177	59	EPS0059F06mN	EPS0059F09mN
7.91	201	67	EPS0067F06mN	EPS0067F09mN
8.39	213	71	EPS0071F06mN	EPS0071F09mN
8.86	225	75	EPS0075F06mN	EPS0075F09mN
9.92	252	84	EPS0084F06mN	EPS0084F09mN
10.04	255	85	EPS0085F06mN	EPS0085F09mN
10.51	267	89	EPS0089F06mN	EPS0089F09mN
11.22	285	95	EPS0095F06mN	EPS0095F09mN
11.81	300	100	EPS0100F06mN	EPS0100F09mN
12.28	312	104	EPS0104F06mN	EPS0104F09mN
12.52	318	106	EPS0106F06mN	EPS0106F09mN
13.35	339	113	EPS0113F06mN	EPS0113F09mN
14.29	363	121	EPS0121F06mN	EPS0121F09mN
15.12	384	128	EPS0128F06mN	EPS0128F09mN
15.35	390	130	EPS0130F06mN	EPS0130F09mN
16.54	420	140	EPS0140F06mN	EPS0140F09mN
17.60	447	149	EPS0149F06mN	EPS0149F09mN
18.66	474	158	EPS0158F06mN	EPS0158F09mN
19.13	486	162	EPS0162F06mN	EPS0162F09mN
19.72	501	167	EPS0167F06mN	EPS0167F09mN
20.20	513	171	EPS0171F06mN	EPS0171F09mN
20.91	531	177	EPS0177F06mN	EPS0177F09mN
22.20	564	188	EPS0188F06mN	EPS0188F09mN
23.50	597	199	EPS0199F06mN	EPS0199F09mN
24.92	633	211	EPS0211F06mN	EPS0211F09mN
26.34	669	223	EPS0223F06mN	EPS0223F09mN

E*P*S HTD® TIMING PULLEYS

3mm HTD® Pitch, 9mm Belt Width, No Flanges

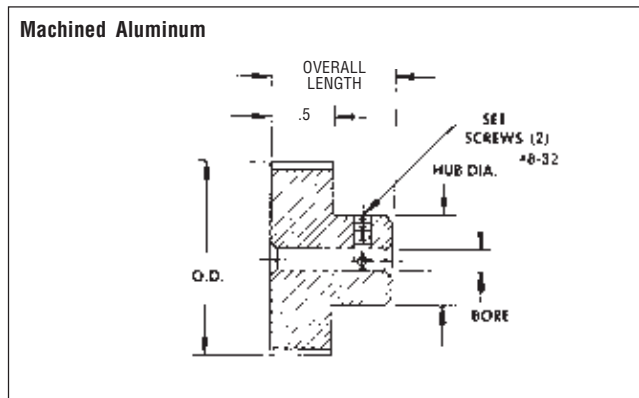

Material: Aluminum Alloy, Anodized

O.D. Tolerance	
O.D.	Tol
Thru 1.000	+.002
1.001-2.000	+.003
2.001-4.000	+.004

No. of Grooves	Pitch Diameter	Outside Diameter	Overall Length ±.016	Hub Diameter ±.016	Standard Bore +.001 - .000	Part Number
18	.677	.647	.812	.442	.250	PT018F08L09N
19	.714	.684	.812	.468	.250	PT019F08L09N
20	.752	.722	.812	.500	.250	PT020F08L09N
22	.827	.797	.812	.562	.250	PT022F08L09N
24	.902	.872	.812	.625	.250	PT024F08L09N
25	.940	.910	.812	.625	.250	PT025F08L09N
26	.977	.947	.812	.625	.250	PT026F08L09N
28	1.053	1.023	.812	.701	.250	PT028F08L09N
30	1.128	1.098	.812	.776	.250	PT030F08L09N
32	1.203	1.173	.812	.851	.250	PT032F08L09N
34	1.278	1.248	.834	.921	.250	PT034F08L09N
36	1.353	1.323	.834	1.000	.250	PT036F08L09N
38	1.429	1.399	.834	1.075	.250	PT038F08L09N
40	1.504	1.474	.834	1.150	.250	PT040F08L09N
44	1.654	1.624	.834	1.300	.250	PT044F08L09N
48	1.805	1.775	.875	1.250	.313	PT048F10L09N
50	1.880	1.850	.875	1.250	.313	PT050F10L09N
56	2.105	2.075	.875	1.250	.313	PT056F10L09N
60	2.256	2.226	.875	1.250	.313	PT060F10L09N
62	2.331	2.301	.875	1.250	.313	PT062F10L09N
72	2.707	2.677	.875	1.250	.313	PT072F10L09N

Special: Materials, bores, hub styles, integral bushings or bearings, widths, finishes, sizes, etc., consult factory.

E*P*S HTD® TIMING PULLEYS

3mm HTD® Pitch, 6mm Belt Width, Double Flange

Machined Aluminum

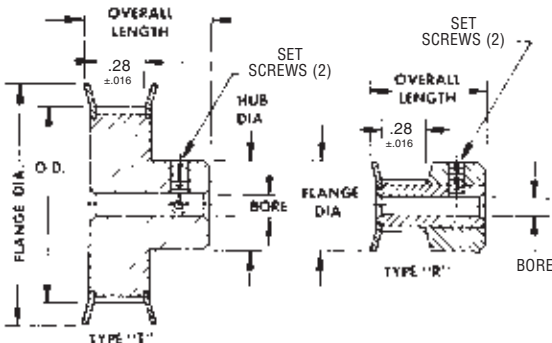

Material: Aluminum Alloy, Anodized.

Bore	Set Screw	Quantity
.125	#4-40	1
.188	#6-40*	2*
.250	#8-32	2

O.D. Tolerance	
O.D.	Tol
Thru 1.000	+ .002
1.001-2.000	+ .003
2.001-4.000	+ .004

* 12 groove, #4-40 (1)

No. of Grooves	Type	Pitch Diameter	Outside Diameter	Flange Diameter ±.016	Overall Length ±.016	Hub Diameter ±.016	Bore +.001 - .000	Part Number
10	R	.376	.346	.505	.562	.505	.125	PT010F04L06R
11	R	.414	.384	.530	.562	.530	.125	PT011F04L06R
12	R	.451	.421	.580	.562	.580	.188	PT012F06L06R
13	R	.489	.459	.610	.572	.610	.188	PT013F06L06R
14	R	.526	.496	.635	.572	.635	.188	PT014F06L06R
15	R	.564	.534	.685	.572	.685	.188	PT015F06L06R
16	R	.602	.572	.710	.572	.710	.188	PT016F06L06R
17	R	.639	.609	.740	.572	.740	.188	PT017F06L06R
18	T	.677	.647	.790	.691	.442	.250	PT018F08L06T
19	T	.714	.684	.827	.691	.479	.250	PT019F08L06T
20	T	.752	.722	.895	.691	.500	.250	PT020F08L06T
22	T	.827	.797	.945	.691	.562	.250	PT022F08L06T
24	T	.902	.872	1.025	.691	.625	.250	PT024F08L06T
25	T	.940	.910	1.060	.691	.625	.250	PT025F08L06T
26	T	.977	.947	1.105	.691	.625	.250	PT026F08L06T
28	T	1.053	1.023	1.173	.691	.701	.250	PT028F08L06T
30	T	1.128	1.098	1.250	.691	.776	.250	PT030F08L06T
32	T	1.203	1.173	1.323	.691	.851	.250	PT032F08L06T
34	T	1.278	1.248	1.398	.713	.921	.250	PT034F08L06T
36	T	1.353	1.323	1.473	.713	1.000	.250	PT036F08L06T
38	T	1.429	1.399	1.549	.713	1.075	.250	PT038F08L06T
40	T	1.504	1.474	1.625	.713	1.150	.250	PT040F08L06T
44	T	1.654	1.624	1.775	.713	1.300	.250	PT044F08L06T

Specials: Materials, bores, hub styles, integral bushings or bearings, widths, finishes, sizes, etc., consult factory.

E*P*S HTD® TIMING PULLEYS

3mm HTD® Pitch, 9mm Belt Width, Double Flange

Machined Aluminum

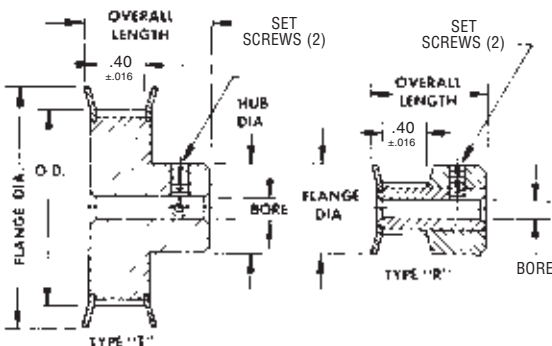

Material: Aluminum Alloy, Anodized.

Bore	Set Screw	Quantity
.125	#4-40	1
.188	#6-40*	2*
.250	#8-32	2

O.D. Tolerance	
O.D.	Tol
Thru 1.000	+ .002
1.001-2.000	+ .003
2.001-4.000	+ .004

* 12 groove, #4-40 (1)

No. of Grooves	Type	Pitch Diameter	Outside Diameter	Flange Diameter ±.016	Overall Length ±.016	Hub Diameter ±.016	Bore +.001 - .000	Part Number
10	R	.376	.346	.505	.681	.505	.125	PT010F04L09R
11	R	.414	.384	.530	.681	.530	.125	PT011F04L09R
12	R	.451	.421	.580	.681	.580	.188	PT012F06L09R
13	R	.489	.459	.610	.691	.610	.188	PT013F06L09R
14	R	.526	.496	.635	.691	.635	.188	PT014F06L09R
15	R	.564	.534	.685	.691	.685	.188	PT015F06L09R
16	R	.602	.572	.710	.691	.710	.188	PT016F06L09R
17	R	.639	.609	.740	.691	.740	.188	PT017F06L09R
18	T	.677	.647	.790	.812	.442	.250	PT018F08L09T
19	T	.714	.684	.827	.812	.479	.250	PT019F08L09T
20	T	.752	.722	.895	.812	.500	.250	PT020F08L09T
22	T	.827	.797	.945	.812	.562	.250	PT022F08L09T
24	T	.902	.872	1.025	.812	.625	.250	PT024F08L09T
25	T	.940	.910	1.060	.812	.625	.250	PT025F08L09T
26	T	.977	.947	1.105	.812	.625	.250	PT026F08L09T
28	T	1.053	1.023	1.173	.812	.701	.250	PT028F08L09T
30	T	1.128	1.098	1.250	.812	.776	.250	PT030F08L09T
32	T	1.203	1.173	1.323	.812	.851	.250	PT032F08L09T
34	T	1.278	1.248	1.398	.833	.921	.250	PT034F08L09T
36	T	1.353	1.323	1.473	.833	1.000	.250	PT036F08L09T
38	T	1.429	1.399	1.549	.833	1.075	.250	PT038F08L09T
40	T	1.504	1.474	1.625	.833	1.150	.250	PT040F08L09T
44	T	1.654	1.624	1.775	.833	1.300	.250	PT044F08L09T

Specials: Materials, bores, hub styles, integral bushings or bearings, widths, finishes, sizes, etc., consult factory.

E*P*S HTD® TIMING BELTS

5mm HTD® Pitch, 9mm & 15mm Wide

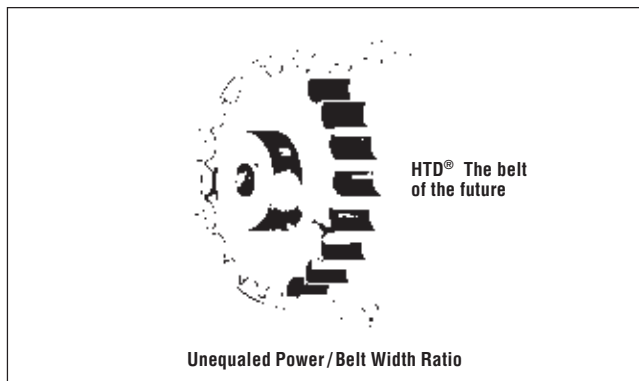

Material: Neoprene with nylon wear surface & helically-wound fiberglass reinforcing

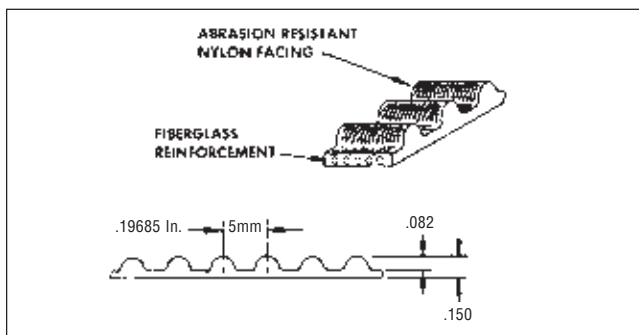

Pitch Length		Number of Grooves	9mm Wide Belts Part Number	15mm Wide Belts Part Number
Inch	mm			
13.78	350	70	EPS0070G09mN	EPS0070G15mN
14.76	375	75	EPS0075G09mN	EPS0075G15mN
15.75	400	80	EPS0080G09mN	EPS0080G15mN
16.73	425	85	EPS0085G09mN	EPS0085G15mN
17.72	450	90	EPS0090G09mN	EPS0090G15mN
18.70	475	95	EPS0095G09mN	EPS0095G15mN
19.69	500	100	EPS0100G09mN	EPS0100G15mN
21.06	535	107	EPS0107G09mN	EPS0107G15mN
22.24	565	113	EPS0113G09mN	EPS0113G15mN
23.62	600	120	EPS0120G09mN	EPS0120G15mN
25.00	635	127	EPS0127G09mN	EPS0127G15mN
26.38	670	134	EPS0134G09mN	EPS0134G15mN
27.95	710	142	EPS0142G09mN	EPS0142G15mN
29.13	740	148	EPS0148G09mN	EPS0148G15mN
31.50	800	160	EPS0160G09mN	EPS0160G15mN
33.46	850	170	EPS0170G09mN	EPS0170G15mN
35.04	890	178	EPS0178G09mN	EPS0178G15mN
37.40	950	190	EPS0190G09mN	EPS0190G15mN
39.37	1000	200	EPS0200G09mN	EPS0200G15mN

E*P*S HTD® TIMING PULLEYS

5mm HTD® Pitch, 9mm & 15mm Belt Width, No Flanges

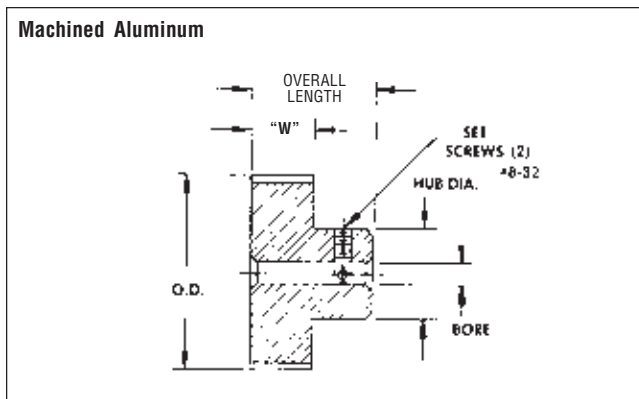

Material: Aluminum Alloy, Anodized

Number of Grooves	Overall Length ±.016		Face Width "W"	
	9mm Width	15mm Width	9mm	15mm
12-22	.796	1.032		
24-34	.859	1.093		
36-40	.937	1.187		
			"W"	.541 .781

No. of Grooves	Pitch Dia.	Outside Dia.	Hub Dia. ±.016	Bore +.001 -.000	9mm Belt Width Part Number	15mm Belt Width Part Number
12	.752	.707	.437	.250	PT012G08L09N	PT012G08L15N
13	.815	.770	.500	.250	PT013G08L09N	PT013G08L15N
14	.877	.832	.500	.250	PT014G08L09N	PT014G08L15N
15	.940	.895	.562	.250	PT015G08L09N	PT015G08L15N
16	1.003	.958	.562	.250	PT016G08L09N	PT016G08L15N
17	1.065	1.020	.625	.250	PT017G08L09N	PT017G08L15N
18	1.128	1.083	.687	.250	PT018G08L09N	PT018G08L15N
19	1.191	1.146	.750	.250	PT019G08L09N	PT019G08L15N
20	1.253	1.208	.812	.250	PT020G08L09N	PT020G08L15N
22	1.379	1.334	.937	.250	PT022G08L09N	PT022G08L15N
24	1.504	1.459	1.000	.250	PT024G08L09N	PT024G08L15N
25	1.566	1.521	1.000	.250	PT025G08L09N	PT025G08L15N
26	1.629	1.584	1.062	.250	PT026G08L09N	PT026G08L15N
28	1.754	1.709	1.187	.250	PT028G08L09N	PT028G08L15N
30	1.880	1.835	1.187	.250	PT030G08L09N	PT030G08L15N
32	2.005	1.960	1.250	.250	PT032G08L09N	PT032G08L15N
34	2.130	2.085	1.375	.250	PT034G08L09N	PT034G08L15N
36	2.256	2.211	1.500	.313	PT036G10L09N	PT036G10L15N
38	2.381	2.336	1.500	.313	PT038G10L09N	PT038G10L15N
40	2.506	2.461	1.500	.313	PT040G10L09N	PT040G10L15N

Special: Materials, bores, hub styles, integral bushings or bearings, widths, finishes, sizes, etc., consult factory.

E*P*S HTD® TIMING PULLEYS

5mm HTD® Pitch, 9mm Belt Width, Double Flange

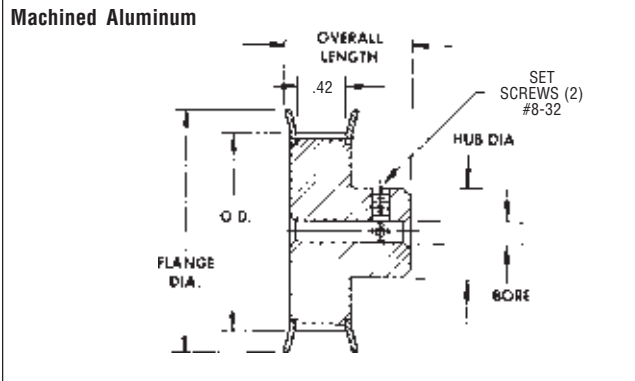

Material: Aluminum Alloy, Anodized.

O.D. Tolerance	
O.D.	Tol
Thru 1.000	+.002
1.001-2.000	+.003
2.001-4.000	+.004

No. of Grooves	Pitch Diameter	Outside Diameter	Flange Diameter ±.016	Overall Length ±.016	Hub Diameter ±.016	Standard Bore +.001 - .000	Standard Bore Part Number
12	.752	.707	.875	.790	.437	.250	PT012G08L09T
13	.815	.770	.939	.790	.500	.250	PT013G08L09T
14	.877	.832	1.000	.790	.500	.250	PT014G08L09T
15	.940	.895	1.063	.790	.562	.250	PT015G08L09T
16	1.003	.958	1.094	.790	.625	.250	PT016G08L09T
17	1.065	1.020	1.188	.790	.625	.250	PT017G08L09T
18	1.128	1.083	1.250	.790	.687	.250	PT018G08L09T
19	1.191	1.146	1.313	.790	.750	.250	PT019G08L09T
20	1.253	1.208	1.375	.790	.812	.250	PT020G08L09T
22	1.379	1.334	1.500	.790	.937	.250	PT022G08L09T
24	1.504	1.459	1.625	.852	1.000	.250	PT024G08L09T
25	1.566	1.521	1.688	.852	1.000	.250	PT025G08L09T
26	1.629	1.584	1.750	.852	1.062	.250	PT026G08L09T
28	1.754	1.709	1.875	.852	1.187	.250	PT028G08L09T
30	1.880	1.835	2.000	.852	1.187	.250	PT030G08L09T
32	2.005	1.960	2.125	.852	1.250	.250	PT032G08L09T
34	2.130	2.085	2.250	.852	1.375	.250	PT034G08L09T

Specials: Materials, bores, hub styles, integral bushings or bearings, widths, finishes, sizes, etc., consult factory.

E*P*S HTD® TIMING PULLEYS

5mm HTD® Pitch, 15mm Belt Width, Double Flange

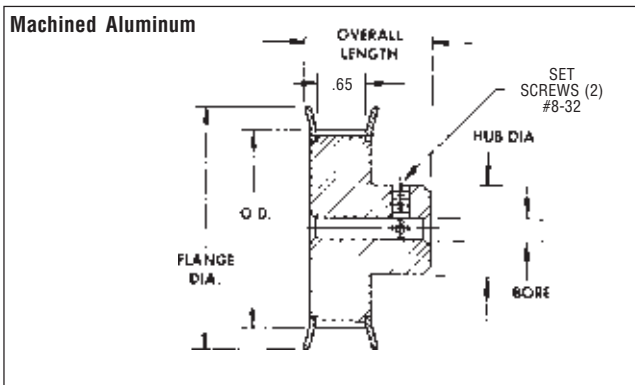

Material: Aluminum Alloy, Anodized.

O.D. Tolerance	
O.D.	Tol
Thru 1.000	+.002
1.001-2.000	+.003
2.001-4.000	+.004

No. of Grooves	Pitch Diameter	Outside Diameter	Flange Diameter ±.016	Overall Length ±.016	Hub Diameter ±.016	Standard Bore +.001 - .000	Standard Bore Part Number
12	.752	.707	.875	1.025	.437	.250	PT012G08L15T
13	.815	.770	.939	1.025	.500	.250	PT013G08L15T
14	.877	.832	1.000	1.025	.500	.250	PT014G08L15T
15	.940	.895	1.063	1.025	.562	.250	PT015G08L15T
16	1.003	.958	1.094	1.025	.625	.250	PT016G08L15T
17	1.065	1.020	1.188	1.025	.625	.250	PT017G08L15T
18	1.128	1.083	1.250	1.025	.687	.250	PT018G08L15T
19	1.191	1.146	1.313	1.025	.750	.250	PT019G08L15T
20	1.253	1.208	1.375	1.025	.812	.250	PT020G08L15T
22	1.379	1.334	1.500	1.025	.937	.250	PT022G08L15T
24	1.504	1.459	1.625	1.087	1.000	.250	PT024G08L15T
25	1.566	1.521	1.688	1.087	1.000	.250	PT025G08L15T
26	1.629	1.584	1.750	1.087	1.062	.250	PT026G08L15T
28	1.754	1.709	1.875	1.087	1.187	.250	PT028G08L15T
30	1.880	1.835	2.000	1.087	1.187	.250	PT030G08L15T
32	2.005	1.960	2.125	1.087	1.250	.250	PT032G08L15T
34	2.130	2.085	2.250	1.087	1.375	.250	PT034G08L15T

Specials: Materials, bores, hub styles, integral bushings or bearings, widths, finishes, sizes, etc., consult factory.

ROUND BELTS AND PRECISION GROOVED PULLEYS

Round belts are manufactured from a polyurethane seal compound that finds use in drive belt applications where petroleum and chemical products may be encountered and temperatures will not exceed 180°F. The flex life and abrasion resistance of this belt are excellent. The formulas listed on this and the adjacent page are to be used in the selection of belt length and pulley size for the Round Belt drive system.

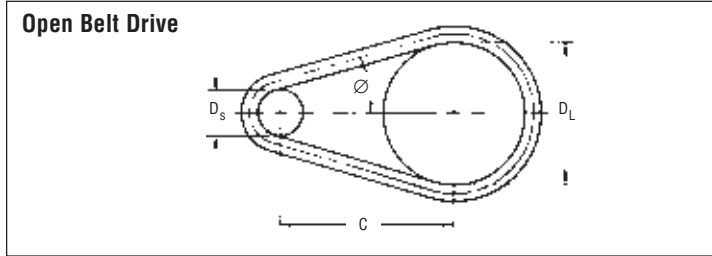

Open Belt Drives are used in most applications. In a crossed belt drive, the direction of rotation of the driven pulley is reversed. If the axes of the pulleys are parallel to each other, the two belts will rub at the crossing point; this may cause premature wearing of the belt. Tilting one axis will eliminate rubbing of the belt, but may complicate the design of the drive.

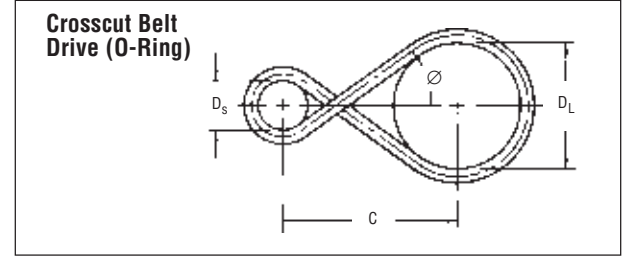

The following formulas are to calculate the belt length for either an Open Belt or Cross Cut Belt drive. Tensile = 3,500 psi.

Open Belt Drive	Cross Cut Belt Drive
$\sin \phi = \frac{DL - DS}{2C}$	$\sin \phi = \frac{DL + DS}{2C}$
Belt Half Angle ϕ	
Length of Belt Under Tension	
$L1 = \frac{\pi}{2} (DL + DS) + \frac{\pi \phi}{180} (DL - DS) + 2C \cos \phi$	$L1 = \left[\frac{\pi}{2} \left(1 + \frac{\phi}{90} \right) (DL + DS) \right] + 2C \cos \phi$
Free Belt Length	
$LF = L1 (.88)$	Inside Diameter Of Belt
	$ID = \frac{LF}{\pi} - W$

NOTE: It is recommended that belt be installed with an initial stretch of approx. 12%

The pulleys are available in aluminum for the 1/6", 3/32" and 3/16" diameter belts. Pulleys for 1/8" and 1/4" diameter belts are available as a standard in stainless steel. The outside diameter of the pulley is equivalent to the pitch diameter of the pulley; therefore the diameters listed could be used to determine the proper ratio. For maximum flex life, the diameter of the smaller pulleys should be at least six times the actual belt width W.

Nominal Belt Size	W	Minimum Pulley Diameter
1/16"	.070	.42
3/32"	.103	.618
1/8"	.139	.834
3/16"	.210	1.260
1/4"	.275	1.650

DS = Smaller Diameter Pulley
DL = Larger Diameter Pulley

The ratio of change in speed is DL/DS

1/16" Diameter

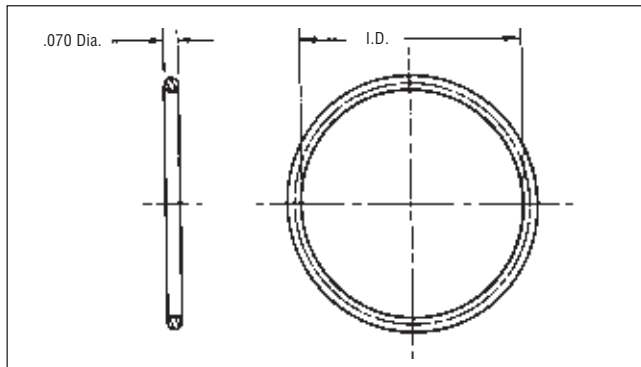

Material: Polyurethane

Temperature Range: -30° to +180°F 83 Durometer

Inside Cir. Approx.	I.D.	Part Number	Inside Cir. Approx.	I.D.	Part Number
4.71	1.489	AF2-1	8.63	2.739	AF2-9
5.49	1.739	AF2-2	9.03	2.864	AF2-10
6.28	1.989	AF2-3	9.42	2.989	AF2-11
6.67	2.114	AF2-4	10.21	3.239	AF2-12
7.06	2.239	AF2-5	10.99	3.489	AF2-13
7.46	2.364	AF2-6	11.78	3.739	AF2-14
7.85	2.489	AF2-7	12.56	3.989	AF2-15
8.24	2.614	AF2-8			

For 1/16" Diameter Pulley Belts

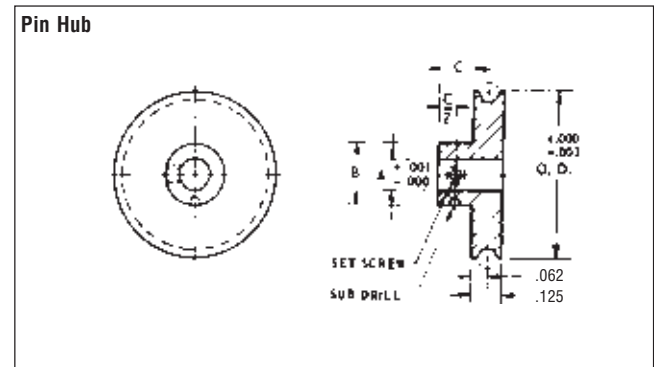

Material: 2024-T4 Aluminum, Anodized

Shaft Size	O.D.	A	B	C	Set Screw	Part Number
1/8	.500	.1248	.312	.187	#2-56	AE5-1
	.750					AE5-2
	1.000					AE5-3
	1.500					AE5-4
	2.000					AE5-5
3/16	.500	.1873	.375	.218	#4-40	AE6-1
	.750					AE6-2
	1.000					AE6-3
	1.500					AE6-4
	2.000					AE6-5
1/4	1.000	.2498	.500	.250	#6-32	AE7-1
	1.500					AE7-2
	2.000					AE7-3
	2.500					AE7-4
	3.000					AE7-5

ROUND BELTS AND PRECISION GROOVED PULLEYS

3/32" Diameter

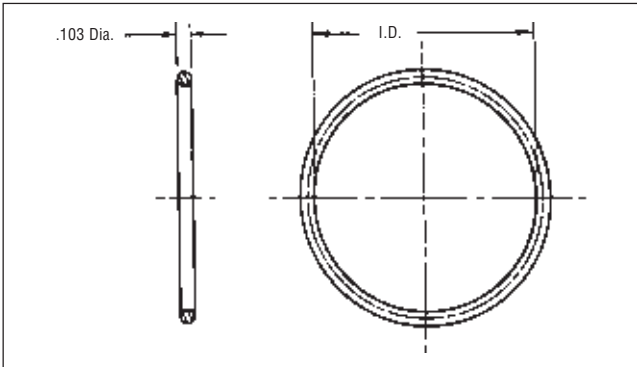

Material: Polyurethane

Temperature Range: -30° to +180°F 83 Durometer

Inside Cir. Approx.	I.D.	Part Number	Inside Cir. Approx.	I.D.	Part Number
7.85	2.487	AF3-1	14.13	4.487	AF3-9
8.63	2.737	AF3-2	14.92	4.737	AF3-10
9.42	2.800	AF3-3	15.70	4.987	AF3-11
10.21	3.237	AF3-4	16.29	5.237	AF3-12
10.99	3.487	AF3-5	17.27	5.487	AF3-13
11.78	3.737	AF3-6	18.06	5.737	AF3-14
12.56	3.987	AF3-7	18.84	5.987	AF3-15
13.35	4.237	AF3-8			

For 3/32" Diameter Pulley Belts

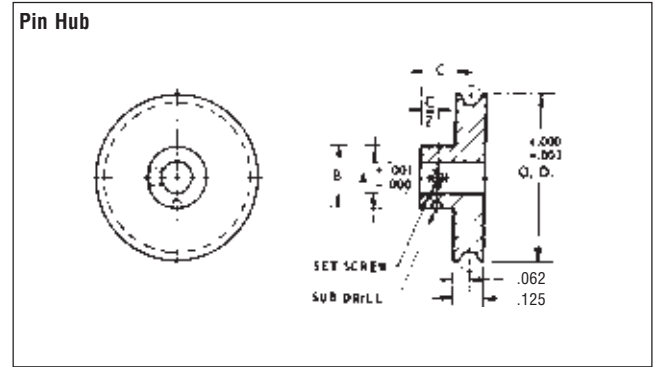

Material: 2024-T4 Aluminum, Anodized

Shaft Size	O.D.	A	B	C	Set Screw	Part Number
1/8	.500	.1248	.312	.187	#2-56	AE8-1
	.750					AE8-2
	1.000					AE8-3
	1.500					AE8-4
	2.000					AE8-5
3/16	.500	.1873	.375	.218	#4-40	AE9-1
	.750					AE9-2
	1.000					AE9-3
	1.500					AE9-4
	2.000					AE9-5
1/4	1.000	.2498	.500	.250	#6-32	AE10-1
	1.500					AE10-2
	2.000					AE10-3
	2.500					AE10-4
	3.000					AE10-5

1/8" Diameter

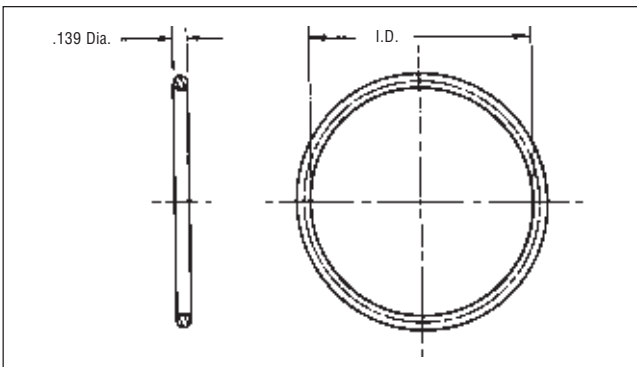

Material: Polyurethane

Temperature Range: -30° to +180°F 83 Durometer

Inside Cir. Approx.	I.D.	Part Number	Inside Cir. Approx.	I.D.	Part Number
13.35	4.234	AF4-1	25.13	7.984	AF4-13
14.13	4.484	AF4-2	26.70	8.484	AF4-14
14.92	4.734	AF4-3	28.27	8.984	AF4-15
15.70	4.984	AF4-4	29.84	9.484	AF4-16
16.49	5.234	AF4-5	31.41	9.984	AF4-17
17.27	5.484	AF4-6	32.98	10.484	AF4-18
18.06	5.734	AF4-7	34.55	10.984	AF4-19
18.84	5.984	AF4-8	36.12	11.484	AF4-20
19.63	6.234	AF4-9	37.69	11.984	AF4-21
20.42	6.484	AF4-10	40.84	12.984	AF4-22
21.99	6.984	AF4-11	43.98	13.984	AF4-23
23.56	7.484	AF4-12	47.12	14.984	AF4-24

For 1/8" Diameter Round Pulley Belts

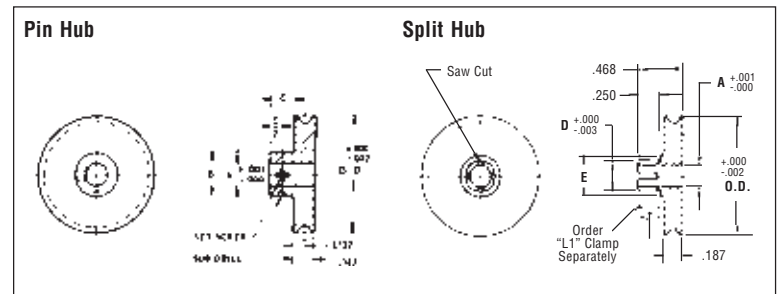

Material: 303 Stainless Steel

Shaft Size	O.D.	A	B	C	D	E	Set Screw	Clamp	Pin Hub Part No.	Split Hub Part No.
1/8	.500	.1248	.312	.187	.188	1/4	#2-56	L1-1 or L1-4	AE-1	AE-21
	.750								AE-2	AE-22
	1.000								AE-3	AE-23
	1.500								AE-4	AE-24
	2.000								AE-5	AE-25
3/16	.500	.1873	.375	.218	.250	5/16	#4-40	L1-2 or L1-5	AE-6	AE-26
	.750								AE-7	AE-27
	1.000								AE-8	AE-28
	1.500								AE-9	AE-29
	2.000								AE-10	AE-30
1/4	.500	.2498	.500	.250	.312	3/8	#6-32	L1-3 or L1-6	AE-11	AE-31
	.750								AE-12	AE-32
	1.000								AE-13	AE-33
	1.500								AE-14	AE-34
	2.000								AE-15	AE-35
	2.500								AE-16	AE-36
	3.000								AE-17	AE-37

ROUND BELTS AND PRECISION GROOVED PULLEYS

3/16" Diameter

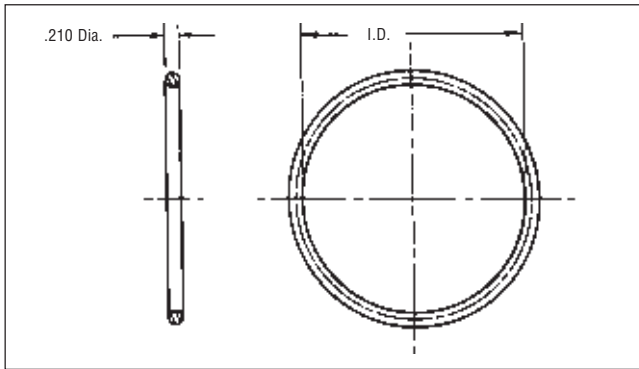

Material: Polyurethane

Temperature Range: -30° to +180°F 83 Durometer

Inside Cir. Approx.	I.D.	Part Number	Inside Cir. Approx.	I.D.	Part Number
6.28	1.975	AF5-1	10.99	3.475	AF5-7
7.06	2.225	AF5-2	11.78	3.725	AF5-8
7.85	2.475	AF5-3	12.56	3.975	AF5-9
8.63	2.725	AF5-4	13.35	4.225	AF5-10
9.42	2.975	AF5-5	14.13	4.475	AF5-11
10.21	3.225	AF5-6			

For 3/16" Diameter Pulley Belts

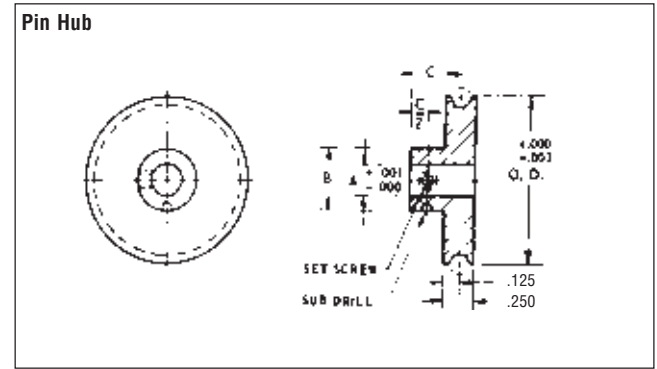

Material: 2024-T4 Aluminum, Anodized

Shaft Size	O.D.	A	B	C	Set Screw	Part Number
1/4	1.000	.2498	.500	.250	#6-32	AE14-1
	1.500					AE14-2
	2.000					AE14-3
	3.000					AE14-4
5/16	1.000	.3123	.750	.375	#8-32	AE15-1
	1.500					AE15-2
	2.000					AE15-3
	3.000					AE15-4
3/8	1.000	.3748	.750	.500	#10-32	AE16-1
	1.500					AE16-2
	2.000					AE16-3
	3.000					AE16-4

1/4" Diameter

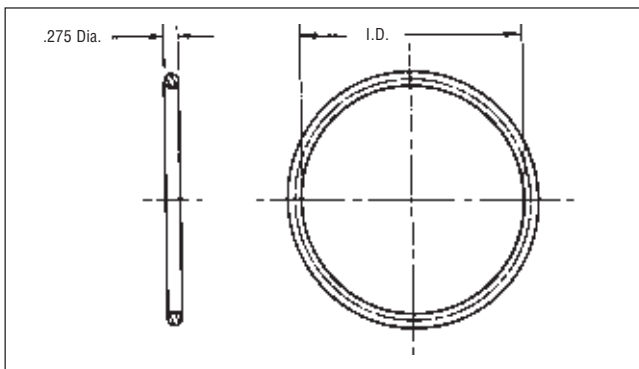

Material: Polyurethane

Temperature Range: -30° to +180°F 83 Durometer

Inside Cir. Approx.	I.D.	Part Number
18.84	5.975	AF6-1
20.42	6.475	AF6-2
21.99	6.975	AF6-3
25.13	7.975	AF6-4
28.27	8.975	AF6-5
31.41	9.975	AF6-6
37.69	11.975	AF6-7
40.84	12.975	AF6-8
43.98	13.975	AF6-9
47.12	14.975	AF6-10

For 1/4" Diameter Pulley Belts

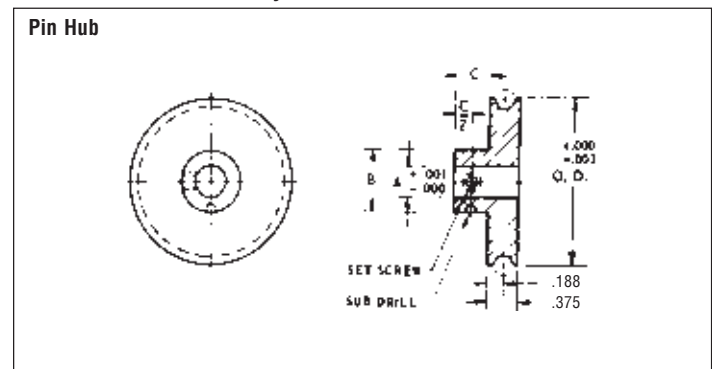

Material: 303 Stainless Steel

Shaft Size	O.D.	A	B	C	Set Screw	Part Number
3/8	1.000	.3748	.750	.500	#10-32	AE17-1
	1.500					AE17-2
	2.000					AE17-3
	3.000					AE17-4
	4.000					AE17-5
1/2	1.000	.4998	1.000	.500	#1/4-20	AE18-1
	1.500					AE18-2
	2.000					AE18-3
	3.000					AE18-4
	4.000					AE18-5

.250 PITCH CHAIN AND SPROCKETS

#25 Roller Chain

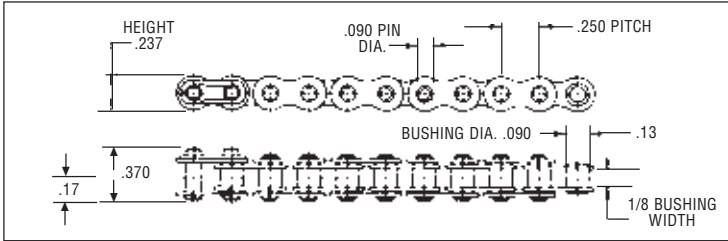

Chain Material: Stainless Steel Type 18-8 Weight per Foot: .0828 lbs.
Tensile Strength: 700 lbs. Average

Extra Connectors Available
Catalog Number EL25-C

SPRING CLIP

All Chains Supplied With Connectors
Random lengths available: Specify part number by indicating total number of links ÷ 10 after series number. Specify even numbers of links including connector.

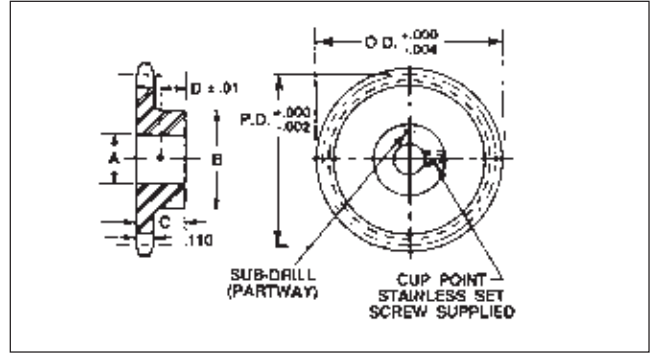

Sprocket Material: Stainless Steel
2024-T4 Aluminum (Anodize Before Cutting)

No. of Teeth	Bore A +.001	B	C	D	Set Size
9-22	1/4	1/2	1/2	.19	#6-32
24-36	3/8	3/4	5/8	.25	#10-32
40-50	1/2	1-1/2	3/4	.31	#10-32

Part Number	L	Part Number	L
EL25-4	10.000	EL25-17	42.500
EL25-5	12.500	EL25-18	45.000
EL25-6	15.000	EL25-19	47.500
EL25-7	17.500	EL25-20	50.000
EL25-8	20.000	EL25-21	52.500
EL25-9	22.500	EL25-22	55.000
EL25-10	25.000	EL25-23	57.500
EL25-12	30.000	EL25-24	60.000
EL25-13	32.500	EL25-25	62.500
EL25-14	35.000	EL25-26	65.000
EL25-15	37.500	EL25-27	67.500
EL25-16	40.000	EL25-28	70.000

Sprocket Data			Stainless Steel	Aluminum
No. Teeth	P.D.	O.D.	Part Number	Part Number
9	.7310	.836	EM255-9	EM256-9
10	.8090	.919	EM255-10	EM256-10
11	.8874	1.001	EM255-11	EM256-11
12	.9659	1.083	EM255-12	EM256-12
13	1.0446	1.164	EM255-13	EM256-13
14	1.1235	1.245	EM255-14	EM256-14
15	1.2024	1.326	EM255-15	EM256-15
16	1.2813	1.406	EM255-16	EM256-16
18	1.4397	1.567	EM255-18	EM256-18
20	1.5981	1.728	EM255-20	EM256-20
21	1.6773	1.808	EM255-21	EM256-21
22	1.7566	1.880	EM255-22	EM256-22

Sprocket Data			Stainless Steel	Aluminum
No. Teeth	P.D.	O.D.	Part Number	Part Number
24	1.9153	2.049	EM255-24	EM256-24
25	1.9946	2.129	EM255-25	EM256-25
26	2.0740	2.209	EM255-26	EM256-26
28	2.2328	2.368	EM255-28	EM256-28
30	2.3917	2.528	EM255-30	EM256-30
32	2.5505	2.688	EM255-32	EM256-32
36	2.8684	3.007	EM255-36	EM256-36
40	3.1863	3.326	EM255-40	EM256-40
45	3.5838	3.725	EM255-45	EM256-45
48	3.8220	3.964	EM255-48	EM256-48
50	3.9815	4.123	EM255-50	EM256-50

.1475 MINIATURE PITCH CHAINS

.1475 Pitch-Prestretched

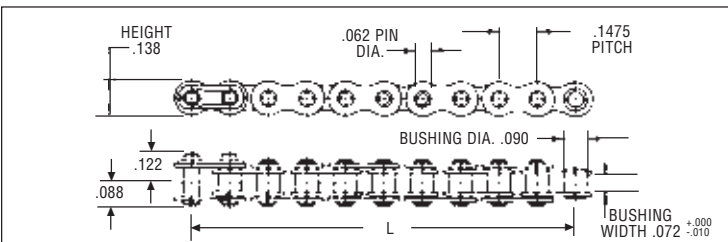

Material: Stainless Steel Type 18-8 Weight per Foot: .035 lbs.
Tensile Strength: 180 lbs. Average

Extra Connectors Available
Catalog Number EL-C

SPRING CLIP

Prestretched For:

- Reduced run in time
- Negligible preload expansion

Part Number	L	Part Number	L	Part Number	L	Part Number	L
EL-4	5.900	EL-13	19.175	EL-22	32.450	EL-31	45.725
EL-5	7.375	EL-14	20.650	EL-23	33.925	EL-32	47.200
EL-6	8.850	EL-15	22.125	EL-24	35.400	EL-33	48.675
EL-7	10.325	EL-16	23.600	EL-25	36.875	EL-34	50.150
EL-8	11.800	EL-17	25.075	EL-26	38.350	EL-35	51.625
EL-9	13.275	EL-18	26.550	EL-27	39.825	EL-36	53.100
EL-10	14.750	EL-19	28.025	EL-28	41.300	EL-37	54.575
EL-11	16.225	EL-20	29.500	EL-29	42.775	EL-38	56.050
EL-12	17.700	EL-21	30.975	EL-30	44.250	EL-39	57.525

All Chains Supplied With Connectors
Random lengths available: Specify part number by indicating total number of links ÷ 10 after series number. Specify even numbers of links including connector.
Example: EL-54.4 contains 544 links; EL-12.8 contains 128 links.
Closed loop chain available on request (specify length)

.1475 PITCH MINIATURE PITCH SPROCKETS

Pin Type Hub

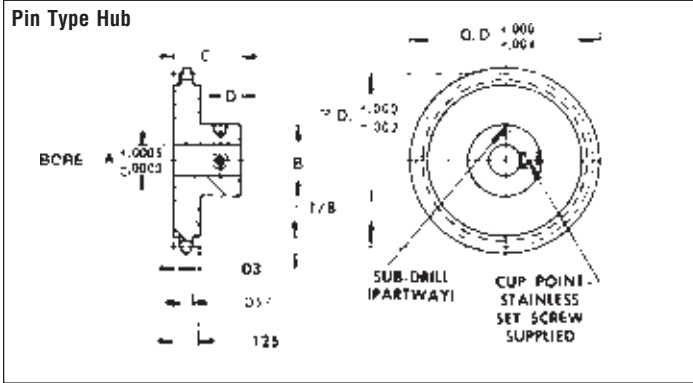

Hubless

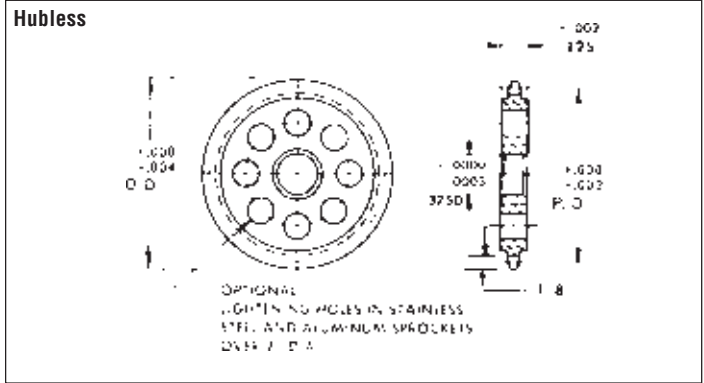

Dimension	Bore				
	1/8	3/16	1/4	4mm	6mm
A	.1248	.1873	.2498	.1573	.2360
B	.312	.375	.500	.375	.500
C	.312	.343	.375	.343	.375
D	.090	.110	.120	.110	.120
Set Screw	#2-56	#4-40	#6-32	M2 x .4	M3 x .5

Material: 303 Stainless Steel
2024-T4 Aluminum (Anodized - Before Cutting)

Sprocket Data			Stainless Steel						Aluminum					
			Pin Hub Part Number Bore Size						Hubless Part No. Bore Size	Pin Hub Part Number Bore Size				
Number Teeth	P.D.	O.D.	.1248	.1873	.2498	4mm	6mm	.3750	.1248	.1873	.2498	4mm	6mm	.3750
9	.431	.483	EM1-9	—	—	—	—	—	EM2-9	—	—	—	—	—
10	.477	.529	EM1-10	EM3-10	—	MMS1-10	—	—	EM2-10	EM4-10	—	MMS2-10	—	—
11	.524	.576	EM1-11	EM3-11	—	MMS1-11	—	—	EM2-11	EM4-11	—	MMS2-11	—	—
12	.570	.622	EM1-12	EM3-12	—	MMS1-12	—	—	EM2-12	EM4-12	—	MMS2-12	—	—
13	.616	.668	EM1-13	EM3-13	EM5-13	MMS1-13	MMS3-13	—	EM2-13	EM4-13	EM6-13	MMS2-13	MMS4-13	—
14	.663	.715	EM1-14	EM3-14	EM5-14	MMS1-14	MMS3-14	—	EM2-14	EM4-14	EM6-14	MMS2-14	MMS4-14	—
15	.709	.761	EM1-15	EM3-15	EM5-15	MMS1-15	MMS3-15	—	EM2-15	EM4-15	EM6-15	MMS2-15	MMS4-15	—
16	.756	.808	EM1-16	EM3-16	EM5-16	MMS1-16	MMS3-16	—	EM2-16	EM4-16	EM6-16	MMS2-16	MMS4-16	—
17	.803	.855	EM1-17	EM3-17	EM5-17	MMS1-17	MMS3-17	—	EM2-17	EM4-17	EM6-17	MMS2-17	MMS4-17	—
18	.849	.901	EM1-18	EM3-18	EM5-18	MMS1-18	MMS3-18	—	EM2-18	EM4-18	EM6-18	MMS2-18	MMS4-18	—
19	.896	.948	EM1-19	EM3-19	EM5-19	MMS1-19	MMS3-19	—	EM2-19	EM4-19	EM6-19	MMS2-19	MMS4-19	—
20	.943	.995	EM1-20	EM3-20	EM5-20	MMS1-20	MMS3-20	—	EM2-20	EM4-20	EM6-20	MMS2-20	MMS4-20	—
21	.990	1.042	EM1-21	EM3-21	EM5-21	MMS1-21	MMS3-21	—	EM2-21	EM4-21	EM6-21	MMS2-21	MMS4-21	—
22	1.036	1.088	EM1-22	EM3-22	EM5-22	MMS1-22	MMS3-22	—	EM2-22	EM4-22	EM6-22	MMS2-22	MMS4-22	—
23	1.083	1.135	EM1-23	EM3-23	EM5-23	MMS1-23	MMS3-23	—	EM2-23	EM4-23	EM6-23	MMS2-23	MMS4-23	—
24	1.130	1.182	EM1-24	EM3-24	EM5-24	MMS1-24	MMS3-24	—	EM2-24	EM4-24	EM6-24	MMS2-24	MMS4-24	—
25	1.177	1.228	EM1-25	EM3-25	EM5-25	MMS1-25	MMS3-25	—	EM2-25	EM4-25	EM6-25	MMS2-25	MMS4-25	—
26	1.224	1.276	EM1-26	EM3-26	EM5-26	MMS1-26	MMS3-26	—	EM2-26	EM4-26	EM6-26	MMS2-26	MMS4-26	—
27	1.270	1.322	EM1-27	EM3-27	EM5-27	MMS1-27	MMS3-27	EM13-27	EM2-27	EM4-27	EM6-27	MMS2-27	MMS4-27	EM14-27
28	1.317	1.369	EM1-28	EM3-28	EM5-28	MMS1-28	MMS3-28	EM13-28	EM2-28	EM4-28	EM6-28	MMS2-28	MMS4-28	EM14-28
29	1.364	1.416	EM1-29	EM3-29	EM5-29	MMS1-29	MMS3-29	EM13-29	EM2-29	EM4-29	EM6-29	MMS2-29	MMS4-29	EM14-29
30	1.411	1.463	EM1-30	EM3-30	EM5-30	MMS1-30	MMS3-30	EM13-30	EM2-30	EM4-30	EM6-30	MMS2-30	MMS4-30	EM14-30
31	1.458	1.510	EM1-31	EM3-31	EM5-31	MMS1-31	MMS3-31	EM13-31	EM2-31	EM4-31	EM6-31	MMS2-31	MMS4-31	EM14-31
32	1.505	1.557	EM1-32	EM3-32	EM5-32	MMS1-32	MMS3-32	EM13-32	EM2-32	EM4-32	EM6-32	MMS2-32	MMS4-32	EM14-32
33	1.552	1.604	EM1-33	EM3-33	EM5-33	MMS1-33	MMS3-33	EM13-33	EM2-33	EM4-33	EM6-33	MMS2-33	MMS4-33	EM14-33
34	1.598	1.650	EM1-34	EM3-34	EM5-34	MMS1-34	MMS3-34	EM13-34	EM2-34	EM4-34	EM6-34	MMS2-34	MMS4-34	EM14-34
35	1.645	1.697	EM1-35	EM3-35	EM5-35	MMS1-35	MMS3-35	EM13-35	EM2-35	EM4-35	EM6-35	MMS2-35	MMS4-35	EM14-35
36	1.692	1.744	EM1-36	EM3-36	EM5-36	MMS1-36	MMS3-36	EM13-36	EM2-36	EM4-36	EM6-36	MMS2-36	MMS4-36	EM14-36
38	1.786	1.838	EM1-38	EM3-38	EM5-38	MMS1-38	MMS3-38	EM13-38	EM2-38	EM4-38	EM6-38	MMS2-38	MMS4-38	EM14-38
40	1.880	1.932	EM1-40	EM3-40	EM5-40	MMS1-40	MMS3-40	EM13-40	EM2-40	EM4-40	EM6-40	MMS2-40	MMS4-40	EM14-40
42	1.974	2.026	EM1-42	EM3-42	EM5-42	MMS1-42	MMS3-42	EM13-42	EM2-42	EM4-42	EM6-42	MMS2-42	MMS4-42	EM14-42
44	2.068	2.120	EM1-44	EM3-44	EM5-44	MMS1-44	MMS3-44	EM13-44	EM2-44	EM4-44	EM6-44	MMS2-44	MMS4-44	EM14-44
45	2.114	2.166	—	—	—	—	—	EM13-45	—	—	—	—	—	EM14-45
48	2.255	2.307	—	—	—	—	—	EM13-48	—	—	—	—	—	EM14-48
50	2.349	2.401	—	—	—	—	—	EM13-50	—	—	—	—	—	EM14-50
52	2.443	2.495	—	—	—	—	—	EM13-52	—	—	—	—	—	EM14-52
54	2.537	2.589	—	—	—	—	—	EM13-54	—	—	—	—	—	EM14-54
55	2.584	2.636	—	—	—	—	—	EM13-55	—	—	—	—	—	EM14-55
56	2.631	2.683	—	—	—	—	—	EM13-56	—	—	—	—	—	EM14-56
60	2.818	2.870	—	—	—	—	—	EM13-60	—	—	—	—	—	EM14-60
65	3.053	3.105	—	—	—	—	—	EM13-65	—	—	—	—	—	EM14-65
70	3.288	3.340	—	—	—	—	—	EM13-70	—	—	—	—	—	EM14-70
72	3.382	3.434	—	—	—	—	—	EM13-72	—	—	—	—	—	EM14-72
75	3.522	3.574	—	—	—	—	—	EM13-75	—	—	—	—	—	EM14-75
80	3.757	3.809	—	—	—	—	—	EM13-80	—	—	—	—	—	EM14-80
85	3.992	4.044	—	—	—	—	—	EM13-85	—	—	—	—	—	EM14-85

BEARINGS

RADIAL BEARINGS & ACCESSORIES



PIC Design has recently added several new bearing products to its already extensive offerings. What's more, PIC has expanded the coverage available from its existing products. The new lines, including Spherical Bearings, Rod Ends, and Tapered Outside Diameter Ball Bearings complement the expanded ABEC and equivalent ISO Ball Bearings. PIC Design ball bearings are available in inch and metric sizes. PIC Design Bearings — a brief overview.

BALL BEARINGS:

PIC offers a comprehensive and varied line of ball bearings. Engineers and designers can precisely select bearings for specific applications. The ABEC rating of a bearing is determined by radial runout and tolerancing:

ABEC-7 Precision Bearings used in instrument applications, disk drives and applications with low noise requirements.

ABEC-3 Semi-Precision Bearings are used in applications such as office equipment and computer print heads.

ABEC-1 Commercial Bearings are used in applications such as gear trains, chain drive systems, and other applications requiring long service life and good load carrying capabilities, but not necessarily high degrees of precision.

Tapered Outside Diameter Precision Bearings eliminate mounting problems in sheet metal or soft metal housings.

Metric Precision Bearings available in standard and extra-small series for use with metric shafts and housings.

Extra Thin section bearings save space and are appropriate for aerospace applications and anywhere a need for reduced weight exists.

EXTENDED INNER RING BEARINGS:

Used to provide a mounting clearance between the inner and outer race.

THRUST BEARINGS:

Designed for low speed and high thrust application. Available in carbon steel and stainless steel materials.

NON-METALLIC BEARINGS:

PIC offers a line of non-corrosive ball bearings which are particularly desirable for use in chemical or magnetic environments.

SPHERICAL BEARINGS:

Designed for use in applications where high loads are present and compensation for angular misalignment is required.

ROD ENDS:

Used as connecting links in many applications, with allowance for angular misalignment.

SINTERED BRONZE BEARINGS:

PIC offers a line of self-lubricating, oil impregnated bronze bearings which are particularly desirable for maintenance free applications.

Precision Bearings: Direct replacement for ball bearings.

Sleeve and Flanged: For inexpensive low speed systems. Available in inch and metric sizes.

ENGINEERED PLASTIC BEARINGS:

Similar to sleeve and flanged bronze bearings, but made of custom blended material for ease of maintenance and lube-free performance.

BEARING MOUNTING ACCESSORIES:

- Cam followers
- Bearing housings
- Shims and spacers
- Pre-load springs

TECHNICAL SECTION

To help customers select the most appropriate bearings for use in particular applications, PIC Design has included an Application Guide and an ABEC and ISO Tolerancing Chart.

The Application Guide assists in determining the bearing quality necessary for your system. If you do not find your specific applications listed, use ones which are most similar.

Table 1. Application Guide

Application	ABEC Grade			
	1	3	5	7
Electric Motors		✓		
Tape Guides				✓
Gyro Gimbals				✓
Commercial Gear Trains	✓	✓		
Precision Gear Trains			✓	✓
AGMA Q14 Gear Trains				✓
Very High Speed Applications				✓
Timing Pulley Supports	✓	✓		
"No-Slip" Pulley Systems		✓	✓	
Chain Drive Systems	✓			
Bread Board Experiments				✓
Computer Disk Drive				✓
Laser Aligning Equipment			✓	✓
Hand Adjusted Settings	✓			
Robotics			✓	✓
Encoder Applications			✓	✓
Office Equipment		✓	✓	
Print Heads		✓	✓	

Table 2. ABEC & ISO Tolerancing Chart

ABEC Grade	Radial Runout		Mean Diameter Tolerance			ISO Class
	Inner Ring	Outer Ring	Bore	O.D.	O.D. Size	
1	.0003	.0005	+0.0000 -.0003	+0.0000 -.0003	0-18 mm	0 (Normal)
3	.0003	.0004	+0.0000 -.0002	+0.0000 -.0003	0-30 mm	6
5	.00015	.0002	+0.0000 -.0002	+0.0000 -.0002	0-30 mm	5
7	.0001	.00015	+0.0000 -.0002	+0.0000 -.0002	0-30 mm	4

This information is intended for reference only. All dimensions are in inches.

BEARING SELECTION:

Bearing Size

A variety of criteria may have an influence on bearing size selection for different installations:

Mating parts. One or more of the bearing dimensions may be governed by the size of a mating part (e.g. shaft, housing).

Capacity. Bearing loading, dynamic and static, will establish minimum capacity requirements and influence size selection because capacity generally increases with size.

Speedability. Smaller bearings can usually operate at higher speeds than large bearings, hence the speed requirement of an application may affect size selection.

Stiffness. Large bearings yield less than small bearings and are the better choice where bearing stiffness is crucial.

Weight. In some cases, bearing weight may have to be considered and factored into the selection process.

Torque. Reducing the ball size and using wider raceway curvatures are tactics which may be used to reduce torque.

AISI 440 stainless steel is the standard material for miniature and instrument bearings and torque tube bearings. It is optional for spindle and turbine bearings. This is a hardenable, corrosion-resistant steel with adequate fatigue resistance, good load-carrying capacity, excellent stability and wear resistance. Operating temperature range is -400°F to 300°F for miniature and instrument bearings.

SAE 52100 chrome steel is the standard material for spindle and turbine bearings. It is also available in many miniature and instrument sizes, and may be preferable when fatigue life and static capacity are critical. This material has excellent capacity, fatigue resistance and stability. Operating temperature limit is 400°F when used in spindle and turbine bearings.

Preloading Techniques

Preloading is the removal of internal clearance in a bearing by applying a permanent thrust load to it. Preloading is used to:

- Eliminate radial and axial play
- Increase system rigidity
- Reduce nonrepetitive runout
- Lessen the difference in contact angles between the balls and both inner and outer rings at very high speeds
- Prevent ball skidding under very high accelerations
- Suppress noise

Bearings should be preloaded as lightly as is necessary to achieve the desired results. This avoids excessive heat generation, which reduces speed capability and bearing life.

There are three basic methods of preloading — springs, axial adjustment and duplex bearings.

Limiting Speeds

Limiting speed is defined as the speed at which the internally generated temperature in a mounted bearing reaches the lowest maximum temperature permissible for any of its components, including the lubricant.

There are many factors which combine to determine the limiting speeds of ball and roller bearings. Therefore it is not possible to calculate these speeds with accuracy. Frequently it is necessary to estimate the speed limit of a bearing on the basis of experience with bearings operating under conditions similar to those in question. For small and medium size bearings of the same type and dimension series, operating under similar conditions, the speed limit is approximately inversely proportional to the bearing bore. For large bearings this no longer applies as their speed limits are relatively lower. A bearing of light section has a higher speed limit than a bearing of heavy section. As a result a more general comparison can be made between speeds of different radial bearings by using the bearing mean diameter d_m as a reference instead of the bore d . From the above, the following formulas are derived:

$$\text{For Radial and Angular Contact Bearings. } N = \frac{A}{d_m}$$

$$\text{Where: } N = \text{The speed Limit, RPM} \\ d_m = \text{The Bearing, mean diameter} = \frac{d + D}{2}$$

d = The bearing bore in mm

D = The bearing O.D., mm

A = A value Single Row Ball: 400,000

Single Row Angular Contact:

Low Contact Angle: 800,000

High Contact Angle: 500,000

The above values for A are useful as a quick orientation regarding speed limits for different bearing types and sizes operating under a moderate load and otherwise favorable conditions.

The speed limits calculated using these formulas and values of A should be considered a maximum. These values apply only to bearings lubricated with oil. When bearings are lubricated with grease, use 70% of the above for A .

EXTENDED INNER RACE BEARINGS

TOLERANCES: ABEC 3 & 7

Material: 440 Stainless Steel

Lubrication: Open - Oil per MIL-L-6085
Double Shielded: Grease per MIL-G-23827

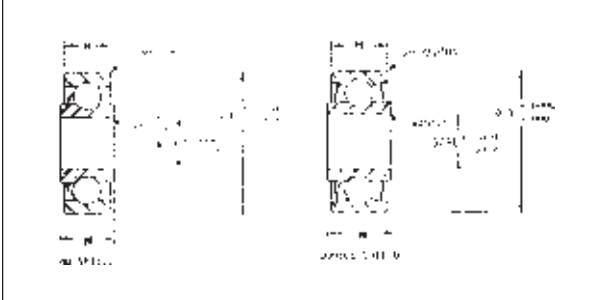

BORE	O.D.	H	W	Shield DATA	ABEC 3 Part No.	ABEC 7 Part No.
.1250	.2500	.0937	.125	Open	E1-OE-3	E1-OE-7
		.1094	.1406	Double Shield	E1-SE-3	E1-SE-7
.1875	.3125	.1094	.1406	Open	E2-OE-3	E2-OE-7
		.125	.1562	Double Shield	E2-SE-3	E2-SE-7
.2500	.3750	.125	.1562	Open	E3-OE-3	E3-OE-7
				Double Shield	E3-SE-3	E3-SE-7
.3125	.5000	.1562	.1875	Open	E4-OE-3	E4-OE-7
				Double Shield	E4-SE-3	E4-SE-7

TAPERED O.D. BEARINGS

TOLERANCES: ABEC 7

Material: 440 Stainless Steel

Lubricated: Grease Per MIL-G-23827
Supplied With Double Shield

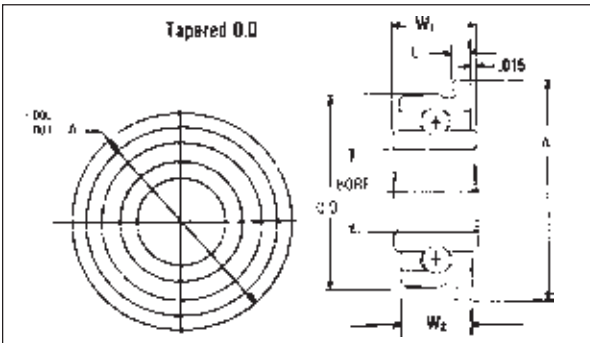

Bore	O.D.	W ₁	W ₂	A	E	Part No.
.1250	.3757	.189	.163	.4380	.037	E8-1
.1875	.5632	.251	.226	.6250	.042	E8-2
.2498	.6257	.251	.226	.6850	.042	E8-3
.3125	.6887	.251	.226	.7500	.042	E8-4

EXTRA THIN BALL BEARINGS

TOLERANCES: ABEC-5 OPEN

Material: 440 Stainless Steel
Oil Per MIL-L-6085

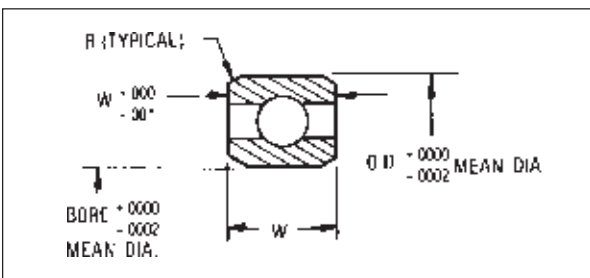

Bore	O.D.	W	R	Load Rating		Part No.
				Dyn.	Static	
.3750	.6250	.1562	.010	96	53	E5-1
.5000	.7500	.1562	.010	112	67	E5-2
.6250	.8750	.1562	.010	116	81	E5-3
.7500	1.0000	.1562	.010	129	98	E5-4

PRECISION BALL BEARINGS

ABEC 1,3, And 7 Tolerances

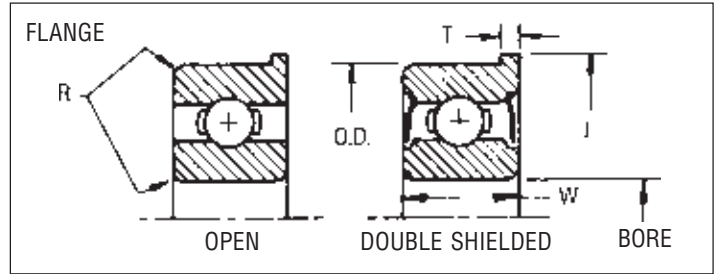
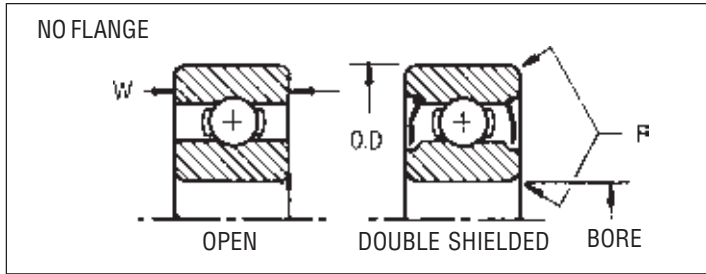

Material: ABEC 3 & 7 440 Stainless Steel
ABEC 1 - 52100 Steel

Lubrication: Open - Oil per MIL-L-6085
Double Shielded & Sealed: Grease per MIL-G-23827

Standard Radial Play: .0002-.0005 (Inch)
0.005-0.013 (Millimeter)

Sealed: Buna N Rubber or Teflon at PIC Option

Bore	O.D.	W	F	T	R Radius	Shield Data	Radial Load Rating (lbs.)		No Flange			Flanged			
							Dynamic	Static	ABEC 1 Part No.	ABEC 3 Part No.	ABEC 7 Part No.	ABEC 1 Part No.	ABEC 3 Part No.	ABEC 7 Part No.	
.0400	.1250	.0469			.003	Open	19	6		E1-16-3	E1-16				
.0469	.1562	.0625 .0937	.203	.013 .031	.005	Open Dbl. Shield	27	9		E3-11-3 E3-12-3	E3-11 E3-12		E4-11-3 E4-12-3	E4-11 E4-12	
.0550	.1875	.0781 .1094	.234	.023 .031	.005	Open Dbl. Shield	46	14		E3-13-3 E3-14-3	E3-13 E3-14		E4-13-3 E4-14-3	E4-13 E4-14	
.0781	.2500	.0937 .1406	.296	.023 .031	.006	Open Dbl. Shield	59	19		E3-1-3 E3-2-3	E3-1 E3-2		E4-1-3 E4-2-3	E4-1 E4-2	
.0937	.1875	.0625 .0937	.234	.018 .031	.006	Open Dbl. Shield	34	10	E13-01 E13-S1	E13-03 E13-S3	E13-07 E13-S7	E13-01F E13-S1F	E13-03F E13-S3F	E13-07F E13-S7F	
.0937	.3125	.1094 .1406	.359	.023 .031	.006	Open Dbl. Shield	101	33		E3-3-3 E3-4-3	E3-3 E3-4		E4-3-3 E4-4-3	E4-3 E4-4	
.1250	.2500	.0937 .1094	.296	.023 .031	.005	Open Dbl. Shield	51	18		E3-5-3 E3-6-3	E3-5 E3-6		E4-5-3 E4-6-3	E4-5 E4-6	
.1250	.3125	.1094 .1406	.359	.023 .031	.006	Open Dbl. Shield	100	32		E3-7-3 E3-8-3	E3-7 E3-8		E4-7-3 E4-8-3	E4-7 E4-8	
.1250	.3750	.1094 .1406	.422	.023 .031	.005	Open Dbl. Shield	102	33				E2-16-1 E2-17-1	E2-16-3 E2-17-3	E2-16 E2-17	
.1250	.3750	.1562	.440	.030	.012	Open Dbl. Shield Dbl. Seal	115	41	E1-1-1 E6-2 E6-3	E1-1-3 E1-3-3	E1-1 E1-3	E2-1-1 E2-3-1	E2-1-3 E2-3-3	E2-1 E2-3	
.1562	.3125	.1094 .1250	.359	.023 .036	.006	Open Dbl. Shield	70	26	E14-01 E14-S1	E14-03 E14-S3	E14-07 E14-S7	E14-01F E14-S1F	E14-03F E14-S3F	E14-07F E14-S7F	
.1875	.3125	.1094 .1250	.359	.023 .036	.006	Open Dbl. Shield	70	26	E15-01 E15-S1	E15-03 E15-S3	E15-07 E15-S7	E15-01F E15-S1F	E15-03F E15-S3F	E15-07F E15-S7F	
.1875	.3750	.1250	.422	.023 .031	.005	Open Dbl. Shield	129	50	E1-2-1 E1-5-1	E1-2-3 E1-5-3	E1-2 E1-5	E2-2-1 E2-5-1	E2-2-3 E2-5-3	E2-2 E2-5	
.1875	.5000	.1562 .1960 .1960	.565	.042	.012	Open Dbl. Shield Dbl. Seal	236	88	E1-4-1 E6-5 E6-6	E1-4-3 E1-6-3	E1-4 E1-6	E2-4-1 E2-6-1	E2-4-3 E2-6-3	E2-4 E2-6	
.2500	.3750	.1250	.422	.023 .036	.005	Open Dbl. Shield	76	37	E1-8-1 E1-11-1	E1-8-3 E1-11-3	E1-8 E1-11	E2-8-1 E2-11-1	E2-8-3 E2-11-3	E2-8 E2-11	
.2500	.5000	.1250 .1875	.547	.023 .045	.005	Open Dbl. Shield	150	67	E1-12-1 E1-13-1	E1-12-3 E1-13-3	E1-12 E1-13	E2-12-1 E2-13-1	E2-12-3 E2-13-3	E2-12 E2-13	
.2500	.6250	.1960	.690	.042	.012	Open Dbl. Shield Dbl. Seal	265	107	E1-7-1 E6-8 E6-9	E1-7-3 E1-9-3	E1-7 E1-9	E2-7-1 E2-9-1	E2-7-3 E2-9-3	E2-7 E2-9	
.2500	.7500	.2188 .2812			.012	Open Dbl. Shield	434	164	E16-01 E16-S1	E16-03 E16-S3	E16-07 E16-S7				
.3125	.5000	.1562	.547	.031	.016	Open Dbl. Shield	98	42	E6-01 E6-S1	E6-03 E6-S3	E6-07 E6-S7	E6-01F E6-S1F	E6-03F E6-S3F	E6-07F E6-S7F	
.3750	.8750	.2188 .2812 .2812	.969	.062	.016	Open Dbl. Shield Dbl. Seal	599	252	E1-14-1 E6-11 E6-12	E1-14-3 E1-15-3	E1-14 E1-15	E2-14-1 E2-15-1	E2-14-3 E2-15-3	E2-14 E2-15	
.5000	1.125	.2500 .3125	1.225	.062	.016	Open Dbl. Shield	696	402	E7-01 E7-S1	E7-03 E7-S3	E7-07 E7-S7	E7-S1F E7-S3F	E7-S3F E7-S7F	E7-S7F	

Continued on page 6-5

PRECISION BALL BEARINGS

Continued from page 6-4

ABEC 1, 3, and 7 Tolerances

Bore	O.D.	W	F	T	R Radius	Shield Data	Radial Load Rating (lbs.)		No Flange			Flanged								
							Dynamic	Static	ABEC 1 Part No.	ABEC 3 Part No.	ABEC 7 Part No.	ABEC 1 Part No.	ABEC 3 Part No.	ABEC 7 Part No.						
															E9-01 E9-S1	E9-03 E9-S3	E10-01 E10-S1	E10-03 E10-S3	E11-01 E11-S1	E11-03 E11-S3
.6250	1.375	.2812 .3438			.031	Open Dbl. Shield	1072	582												
.7500	1.625	.3125 .4375			.031	Open Dbl. Shield	1688	1048												
.8750	1.875	.3750 .5000			.031	Open Dbl. Shield	1816	1048												
1.000	2.000	.3750 .5000			.031	Open Dbl. Shield	1816	1048												
*1.1250	2.1250	.5000			.031	Open Dbl. Shield	2384	1488												
*1.2500	2.250	.3750 .5000			.031	Open Dbl. Shield	2384	1488												
*1.5000	2.625	.4375 .5625			.031	Open Dbl. Shield	3016	2072												

*Material ABEC 1 and 3 — 52100 chrome steel

METRIC PRECISION BALL BEARINGS

TOLERANCES: ISO Class 4 or Normal

Material: 440 Stainless Steel

Bore	O.D.	W	F	T	R	Shield Data	Radial Load Rating (N)		No Flange Part No.	Flanged Part No.
							Dynamic	Static		
3	7	2.0 3.0	8.1	0.5 0.8	0.2 0.15	Open Shielded	248	88	MBG1-1 MBG2-1	MBG3-1 MBG4-1
3	10	4.0	11.5	1.0	0.3	Open Shielded	504	172	MBG5-1 MBG6-1	MBG7-1 MBG8-1
4	9	2.5 4.0	10.3	0.6 1.0	0.25 0.5	Open Shielded	512	180	MBG1-2 MBG2-2	MBG3-2 MBG4-2
4	13	5.0	15.0	1.0	0.4	Open Shielded	1040	388	MBG5-2 MBG6-2	MBG7-2 MBG8-2
4	16	5.0	18.0	1.0	0.5	Open Shielded	1072	416	MBG5-3 MBG6-3	MBG7-3 MBG8-3
5	11	3.0 5.0	12.5	0.8 1.0	0.3 0.2	Open Shielded	572	226	MBG1-3 MBG2-3	MBG3-3 MBG4-3
5	16	5.0	18.0	1.0	0.5	Open Shielded	1382	540	MBG5-4 MBG6-4	MBG7-4 MBG8-4
6	13	3.5 5.0	15.0	1.0 1.1	0.3 0.2	Open Shielded	864	352	MBG1-4 MBG2-4	MBG3-4 MBG4-4
6	19	6.0	22.0	1.5	0.5	Open Shielded	1868	716	MBG5-5 MBG6-5	MBG7-5 MBG8-5
7	22	7.0			0.3	Open Shielded	2632	1104	MBG7-0 MBG7-S	
8	16	4.0 5.0	18.0	1.0	0.4 0.3	Open Shielded	1000	474	MBG1-5 MBG2-5	MBG3-5 MBG4-5
8	22	7.0	25.0	1.5	0.5	Open Shielded	2632	1104	MBG5-6 MBG6-6	MBG7-6 MBG8-6
10	19	5.0 7.0			0.5	Open Shielded	1372	670	MBG1-6 MBG2-6	
10	26	8.0			0.5	Open	3470	1950	MBG5-7	
12 *	28	8.0			0.5	Open Shielded	4340	1910	MBG10-0 MBG10-S	
15 *	32	9.0			0.5	Open Shielded	4750	2270	MBG15-0 MBG15-S	
20 *	42	12.0			1.0	Open Shielded	7960	4050	MBG20-0 MBG20-S	
25 *	47	12.0			1.0	Open Shielded	8550	4690	MBG25-0 MBG25-S	
30 *	55	13.0			1.5	Open Shielded	11240	6610	MBG30-0 MBG30-S	
40 *	68	15.0			1.5	Open Shielded	14250	9220	MBG40-0 MBG40-S	

* ISO Class Normal 52100 Chrome Steel

SINTERED BRONZE BEARINGS

Sleeve & Flanged

Oil-Impregnated

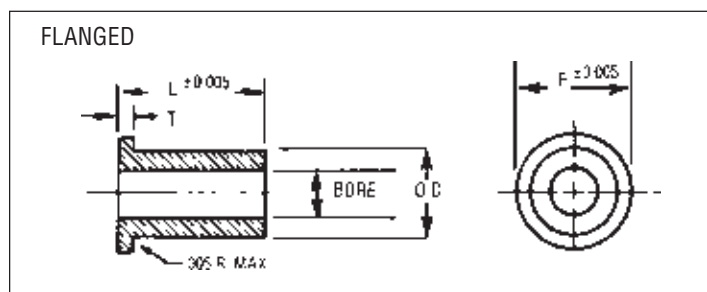
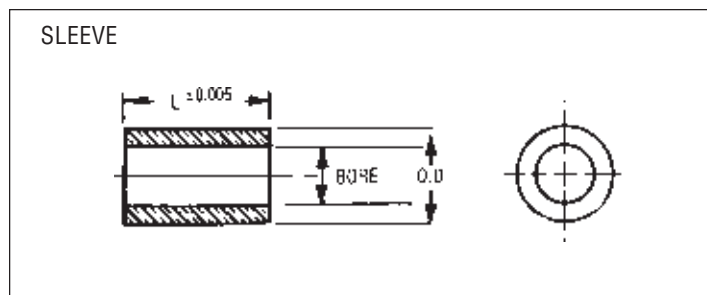

Material: Bronze, MIL-B-438/438
Type 2, Grade 1

Specifications:

Density:	6.4 - 6.8 gm/cm ³	PV (100ft./min.):	50,000
Porosity (% by Vol.):	19 min.	Static, P:	8,000 PSI
Tensile Strength:	14,000 PSI	Dynamic P:	2,000 PSI
Compressive Yield Strength:	11,000 PSI	Speed V:	1,200 fpm

Bearing Design Calculations For Loads & Speed: The load carrying capability of sleeve bearings is expressed by a PV factor in the following formula:

$$PV = \frac{.262 WN}{L}$$

$$P = \frac{W}{LD}$$

$$V = .262 DN$$

Where:
P = Load, PSI
V = Shaft Speed (fpm)

W = Load (lbs.)
L = Bearing Length (In.)
D = Bearing I.D. (In.)
N = Shaft Speed (Rpm)

Recommended Press Fits

Outside Diameter In.	Press Fit, In.	
	Minimum	Maximum
Up to 0.760	0.001	0.003
0.761 to 1.150	0.0015	0.004
1.511 to 2.510	0.002	0.005
2.511 to 3.010	0.002	0.006
Over 3.010	0.002	0.007

Running Clearances

Shaft Size In.	Clearance, min. in.	
	Sintered Bronze	
Up to 0.760	0.0005	
0.761 to 1.150	0.001	
1.511 to 2.510	0.00015	
Over 2.510	0.002	

Shaft Size	Bore +.000 -.001	O.D. +.000 -.001	L ±.005	F ±.005	T ±.0025	Part No. Sleeve	Part No. Flange		
1/8	.127	.252	.125	.360	.047	B10-1 B10-2 B10-3	B11-1 B11-2 B11-3		
			.250						
			.375						
3/16	.189	.314	.250	.370	.047	B10-5 B10-6 B10-7 B10-8	B11-5 B11-6 B11-7 B11-8		
			.375						
			.500						
			.625						
1/4	.252	.377	.250	.560	.047	B10-9 B10-10 B10-11 B10-12	B11-9 B11-10 B11-11 B11-12		
			.375						
			.500						
			.625						
1/4	.252	.439	.375			B10-31 B10-32 B10-33 B10-34			
			.500						
			.625						
			.750						
1/4	.252	.503	.500	.625	.062	B10-49 — B10-51	— B11-50 B11-51		
			.625						
			.750						
5/16	.315	.440	.250	.563	.062	B10-13 B10-14 B10-15 B10-16	B11-13 B11-14 B11-15 B11-16		
			.375						
			.500						
			.625						
3/8	.377	.502	.250	.625	.062		B11-17 B11-18 B11-19 B11-20 B11-21		
			.375						
			.500						
			.625						
3/8	.378	.503	.250			B10-17 B10-18 B10-19 B10-20 B10-21			
			.375						
			.500						
			.625						
1/2	.502	.628	.375			B10-22 B10-23 B10-24 B10-25 B10-26			
			.500						
			.625						
			.750						
1/2	.502	.627	.750	.875	.062		B11-22 B11-23 B11-24 B11-25 B11-26		
			1.000						
5/8	.628	.753	.500			B10-52 B10-53 B10-54			
			.750						
			1.000						
5/8	.627	.753	.500	1.000	.094		B11-52 B11-53 B11-54		
			.750						
			1.000						
3/4	.753	1.003	.500	1.125	.125	B10-55 B10-56 B10-57 B10-58	B11-55 B11-56 B11-57 B11-58		
			.750						
			1.000						
			1.250						
7/8	.878	1.003	.500			B10-59 B10-60 B10-61			
			.750						
		1.128	.625			1.500	.125	— B10-63 B10-64	B11-62 B11-63 B11-64
			.750						
	1.000								
1	1.004	1.254	.500			B10-65 B10-66 B10-67			
			.750						
	1.003	1.253	.750			1.625	.125		B11-68 B11-69 B11-70
			1.000						
	1.250								

METRIC SINTERED BRONZE BEARINGS

Oil-Impregnated

ISO Standard

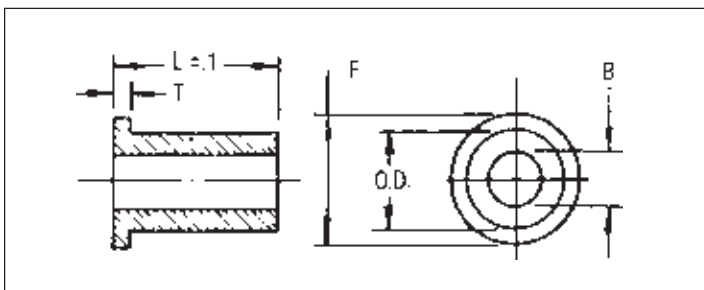
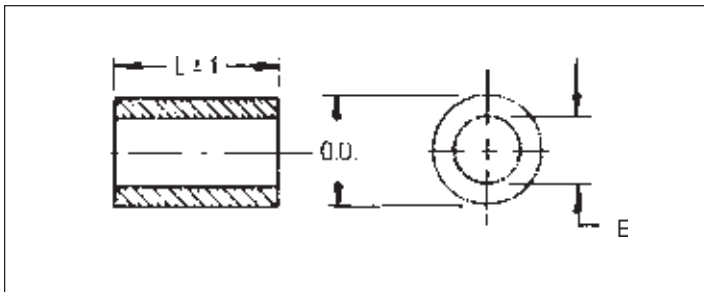

All Dimensions in Millimeters

Material: Bronze, Per MIL-B-438/438
Type 2, Grade 1 (BP 25)

Bearing Tolerances

(Before Fitting):

Bore (B)

Unflanged Bearing F7
Flanged Bearing F8

O.D.

Unflanged Bearing s7
Flanged Bearing s8

Flange

Diameter (F) js13
Thickness (T) js14

T.I.R. O.D. and Bore .060μ

Bore After Assembly

Unflanged H7
Flanged H8

Recommended Housing H7

Features:

Eliminates Lubrication Points

Reduces Maintenance

Max Speed 30,000 rpm

Dynamic Load 1500 daN/cm²

Temperature -20° to +100°c

No Siezing

Permanent Presence of a Veritable Cushion of Oil.

Silent Running

Shaft Size F7	Bore	O.D.	L	F	T	Part No. Unflanged	Part No. Flanged
3	3	6	4	9	1.5	MBG9-1 MBG9-2 MBG9-3	MBG10-1 MBG10-2 MBG10-3
			6				
			10				
4	4	8	4	12	2	MBG9-4 MBG9-5 MBG9-7	MBG10-4 MBG10-5 MBG10-7
			8				
			12				
5	5	8	5	12	2	MBG9-8 MBG9-9 MBG9-10 MBG9-11	
			8				
			12				
			16				
6	6	10	6	14	2	MBG9-12 MBG9-13 MBG9-14 MBG9-15	MBG10-12 MBG10-13 * MBG10-14 MBG10-15
			10				
			12				
			16				
8	8	12	8	16	2	MBG9-16 MBG9-17 MBG9-18	MBG10-16 MBG10-17 MBG10-18
			12				
			16				
10	10	13	10	16	1.5	MBG9-19 MBG9-20 MBG9-21	MBG10-19 MBG10-20 MBG10-21
			16				
			20				
			20				
12	12	17	12	22	2.5	MBG9-22 MBG9-23 MBG9-24	MBG10-22 MBG10-23 MBG10-24
			16				
			20				
			20				
16	16	22	16	28	3	MBG9-25 MBG9-26 MBG9-27	MBG10-25 MBG10-26 MBG10-27
			20				
			25				
			25				
20	20	26	16	32	3	MBG9-28 MBG9-29 MBG9-30 MBG9-31	MBG10-28 MBG10-29 MBG10-30 MBG10-31
			20				
			25				
			32				
25	25	30	20	35	2.5	MBG9-32 MBG9-33 MBG9-34 MBG9-35	MBG10-32 MBG10-33 MBG10-34
			25				
			32				
			40				

* Flange thickness on MBG10-14 = 1.2mm

Tolerances per ISO 286-2 μm

Bore	O.D.	F7	F8	s7	s8
3	6	+16	+21	+31	+37
		+7	+7	+19	+19
4	8	+22	+28	+38	+45
		+10	+10	+23	+23
5	8	+22		+38	
		+10		+23	
6	10	+22	+28	+38	+45
		+10	+10	+23	+23
8	12	+28	+35	+46	+55
		+13	+13	+28	+28
10	13	+28	+35	+46	+55
		+13	+13	+28	+28
12	17	+34	+43	+46	+55
		+16	+16	+28	+28
16	22	+34	+43	+56	+68
		+16	+16	+35	+35
20	26	+41	+53	+56	+68
		+20	+20	+35	+35
25	30	+41	+53	+56	+68
		+20	+20	+35	+35

NON-METALLIC BEARINGS

Sleeve & Flanged

Material: This self-lubricating, maintenance-free bearing is manufactured from a custom blended material that exhibits excellent abrasion resistance and long life. It's an all-purpose bearing for rotational, linear and oscillating movements with low & medium loads.

Specifications:

Operating Temperature Range -40° to 176°F (+338° short term)
 Max PV 3,400 PSI x FPM
 Max V (continuous) FPM Rotating 118 Oscillating 157 Linear 492
 Coefficient of friction approximate .2
 Chemical resistance Parts are resistant to alkalis and most weak organic and inorganic acids. Insoluble in normal organic solution.

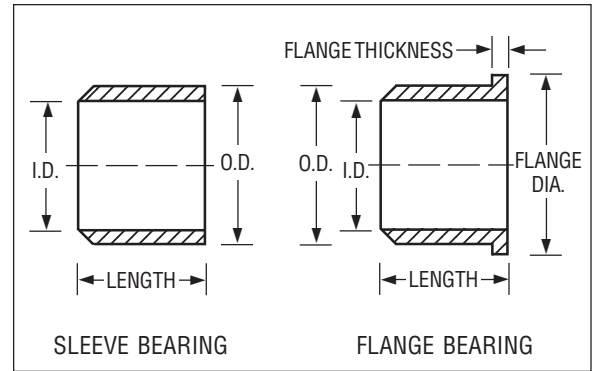

Nominal Sizes					I.D. When In Housing		Housing Bore		Recommend Shaft Size		Sleeve Part No.	Flanged Part No.
I.D.	O.D.	LENGTH	FLG. Dia.	FLG. TH. (-0.0055")	MAX.	MIN.	MAX.	MIN.	MAX.	MIN.		
1/8	1/4	1/4 3/8	.360	.047	.1280	.1262	.2515	.2510	.1250	.1241	BS-0204-04 BS-0204-06	BF-0204-04 BF-0204-06
3/16	5/16	1/4 3/8 1/2	.370	.047	.1905	.1887	.3140	.3135	.1875	.1866	BS-0305-04 BS-0305-06 BS-0305-08	BF-0305-04 BF-0305-06 BF-0305-08
1/4	3/8	1/4 5/16 3/8 1/2	.560	.047	.2539	.2516	.3765	.3760	.2500	.2491	BS-0406-04 BS-0406-05 BS-0406-06 BS-0406-08	BF-0406-04 BF-0406-05 BF-0406-06 BF-0406-08
5/16	7/16	3/8 1/2 5/8	.560	.062	.3164	.3141	.4390	.4385	.3125	.3116	BS-0507-06 BS-0507-08 BS-0507-10	BF-0507-06 BF-0507-08 BF-0507-10
3/8	1/2	3/8 1/2 5/8 3/4	.625	.062	.3789	.3766	.5015	.5010	.3750	.3741	BS-0608-06 BS-0608-08 BS-0608-10 BS-0608-12	BF-0608-06 BF-0608-08 BF-0608-10 BF-0608-12
1/2	5/8	3/8 1/2 5/8 3/4 1	.875	.062	.5047	.5020	.6260	.6250	.5000	.4990	BS-0810-06 BS-0810-08 BS-0810-10 BS-0810-12 BS-0810-16	BF-0810-06 BF-0810-08 BF-0810-10 BF-0810-12 BF-0810-16
5/8	13/16	1/2 5/8 3/4 1	1.063	.156	.6297	.6270	.8135	.8125	.6250	.6240	BS-1013-08 BS-1013-10 BS-1013-12 BS-1013-16	BF-1013-08 BF-1013-10 BF-1013-12 BF-1013-16
3/4	1	5/8 3/4 1	1.250	.156	.7559	.7525	1.0010	1.0000	.7500	.7490	BS-1216-10 BS-1216-12 BS-1216-16	BF-1216-10 BF-1216-12 BF-1216-16
1	1-1/4	1/2 3/4 1	1.500	.188	1.0059	1.0025	1.2510	1.2500	1.0000	.9990	BS-1620-08 BS-1620-12 BS-1620-16	BF-1620-08 BF-1620-12 BF-1620-16

Tolerances for Sleeve and Flange Bearings

(Dimensions shown in inches)

Range	Length	Flange Diameter
1/8 to 3/8	0/-0.0087	-0.0016 / -0.0102
above 3/8 to 11/16	0/-0.0106	-0.0020 / -0.0126
above 11/16 to 1-1/8	0/-0.0130	-0.0026 / -0.0156
above 1-1/8 to 1-15/16	0/-0.0150	-0.0031 / -0.0185
above 1-15/16 to 3-1/8	0/-0.0180	-0.0040 / -0.0220

METRIC NON-METALLIC BEARINGS

Sleeve & Flanged

Material: A custom blended formulation for a self-lubricating, maintenance-free bearing with high performance in almost any environment.

Specifications:

Operating Temperature Range -40° to 82°C
 Max PV (continuous) 0.35 N/mm² x m/sec
 Max P 18 N/mm²
 Max V (continuous) cm/sec
 Rotating 60 Oscillating 80 Linear 250
 Coefficient of Friction approximate .2
 Chemical Resistance Parts are resistant to alkalis and most weak organic and inorganic acids. Insoluble in normal organic solution.

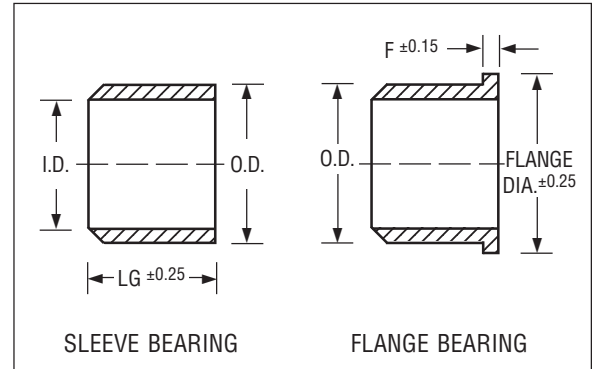

Nominal Sizes					I.D. In Housing		Housing Bore		Recommend Shaft Size		Sleeve Part No.	Flanged Part No.
I.D.	O.D.	LG.	FLG. Dia.	FLG. TH.	MAX.	MIN.	MAX.	MIN.	MAX.	MIN.		
3	6	4	9	1.5	3.078	3.030	6.012	6.000	3.000	2.975	MBS-0306-4	MBF-0306-4
4	8	4	12	2	4.078	4.030	8.015	8.000	4.000	3.970	—	MBF-0408-4 MBF-0408-6
		6									MBS-0408-6	
5	9	5	13	2	5.078	5.030	9.015	9.000	5.000	4.970	MBS-0509-5	MBF-0509-5 MBF-0509-6 MBF-0509-8
		6									—	
		8									MBS-0509-8	
6	10	6	14	2	6.078	6.030	10.015	10.000	6.000	5.970	MBS-0610-6	MBF-0610-6 MBF-0610-10
		10									MBS-0610-10	
8	12	6	16	2	8.098	8.040	12.018	12.000	8.000	7.964	MBS-0812-6	MBF-0812-6 MBF-0812-8 MBF-0812-12
		8									MBS-0812-8	
		12									MBS-0812-12	
10	16	6	20	3	10.130	10.040	16.018	16.000	10.000	9.964	MBS-1016-6	MBF-1016-6 MBF-1016-8 MBF-1016-10 MBF-1016-16
		8									—	
		10									MBS-1016-10	
		16									MBS-1016-16	
12	18	8	24	3	12.160	12.050	18.018	18.000	12.000	11.957	MBS-1218-8	MBF-1218-8 MBF-1218-10 MBF-1218-15 MBF-1218-20
		10									MBS-1218-10	
		15									MBS-1218-15	
		20									MBS-1218-20	
16	22	12	28	3	16.160	16.050	22.021	22.000	16.000	15.957	MBS-1622-12	MBF-1622-12 MBF-1622-15 MBF-1622-20 MBF-1622-25
		15									MBS-1622-15	
		20									MBS-1622-20	
		25									MBS-1622-25	
20	26	15	32	3	20.195	20.065	26.021	26.000	20.000	19.948	MBS-2026-15	MBF-2026-15 MBF-2026-20 MBF-2026-30
		20									MBS-2026-20	
		30									MBS-2026-30	
25	32	20	38	4	25.195	25.065	32.025	32.000	25.000	24.948	MBS-2532-20	MBF-2532-20 MBF-2532-30 MBF-2532-40
		30									MBS-2532-30	
		40									MBS-2532-40	

NON-CORROSIVE BALL BEARINGS

Inch & Metric

Plastic Races

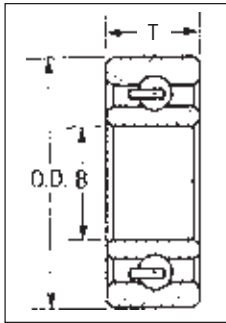

Material: Acetal Races & Cage
Stainless Steel or Glass Balls

Acetal polymer bearings have excellent corrosion resistance & dielectric properties. Ball bearings are available with stainless steel or hard glass balls. The glass balls offer additional corrosion resistance, have good electrical insulation and magnetic properties. These bearings are ideal for use in gas or liquid media and food processing applications. They can be washed and remain corrosion free. Their main features are: resistance to chemicals and corrosion; lubrication free/no maintenance; light weight, low friction, non magnetic properties; operating temperature range from -22° to +220° F (intermittent temperature range from -67° to 284° F).

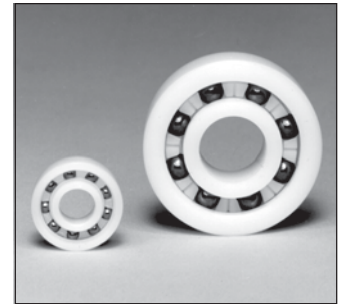

Inch Sizes

B +.003 -.000	O.D. +.000 -.003	T ±.005	Load Capacity Radial (LB)		Max Speed In Air (RPM)	Part No. Ball Type Glass	Part No. Ball Type Stainless Steel
			Dyn.	Static			
.250	.625	.1960	27	18	2300		ES-250
.375	.875	.2187	58	42	1600	EG-375	ES-375
.375	1.375	.4375	86	64	1600	EG-375B	ES-375B
.500	1.125	.2500	84	59	1150	EG-500	ES-500
.500	1.375	.4375	86	60	1150	EG-500B	ES-500B
.625	1.125	.2500	86	64	1070	EG-625	ES-625
.625	1.375	.4375	96	64	1070	EG-625B	ES-625B
1.000*	2.000**	.5000	160	92	750		ES-1000

* Bore Tolerance +.004, -.000

** OD Tolerance +.000, -.004

Metric Sizes

B +.07 -.00	O.D. +.00 -.09	T +.00 -.09	Load Capacity Radial (N)		Max Speed In Air (RPM)	Part No. Ball Type Glass	Part No. Ball Type Stainless Steel
			Dyn.	Static			
6	19	6	65	35	3500	MEG-6	MES-6
8	22	7	80	53	2600	MEG-8	MES-8
10	26	8	160	110	2200	MEG-10	MES-10
12	28	8	240	150	2050	MEG-12	MES-12
15	32	9	280	170	1800	MEG-15	MES-15
17	35	10	325	215	1640	MEG-17	MES-17
20	42	12	415	275	1365	MEG-20	MES-20

TEFLON FILLED POLYMER BEARINGS

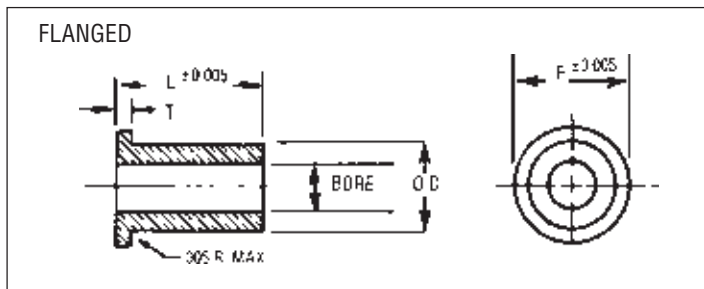
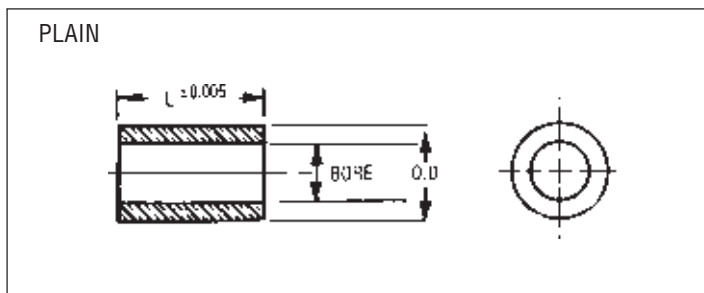

Material: Heavy Duty TFE Filled Polymer
(Practically inert to all acids, bases, and solvents)

Shaft Size	Bore +.002 -.000	O.D. +.000 -.002	L	F	T ±.003	Part No. PLAIN	Part No. FLANGED
1/8"	.126	.253	.250 .375	.360	.047	-	B15-1A B15-2A
1/8"	.129	.253	.250 .375	.344	.062	B14-1 B14-2	B15-1 B15-2
3/16"	.191	.315	.250 .500	.437	.062	B14-3 B14-4	B15-3 B15-4
1/4"	.254	.378	.375 .500	.500	.062	B14-5 B14-6	B15-5 B15-6
5/16"	.316	.437	.375 .500	.562	.062	-	B15-7A B15-8A
5/16"	.316	.503	.375 .500	.625	.094	B14-7 B14-8	B15-7 B15-8
3/8"	.379	.565	.500 .750	.875	.125	B14-9 B14-10	B15-9 B15-10
3/8"	.379	.628	.500 .750	.875	.125	-	B15-13 B15-14
1/2"	.504	.753	.500 1.000	1.000	.125	B14-11 B14-12	B15-11 B15-12

Specifications: Temperature Limits -400° F to +550° F
Coefficient of Friction Approximate 0.20
Recommended Max. PV 10,000 PSI x FPM
Recommended Max V 400 FPM
Recommended Max. P 1000 PSI
Chemical Resistance Excellent
Water Absorption Zero
Outgassing Negligible at 10⁻⁷ TORR

THRUST BEARINGS

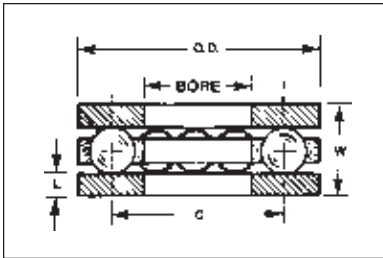

Material: STAINLESS STEEL MODEL

Races — 410 SS. RC 42-45
 Balls — 440C SS Hardened
 Retainer — Nylon 8200

CARBON STEEL MODEL

Races — C1075 Steel. RC 59-61
 Balls — Hardened Carbon Steel
 Retainer — Nylon 8200

Bore +.008 -.008	O.D. +.006 -.008	C	W	L ±.002	NO. OF BALLS	410 Stainless Steel		C1075 Carbon Steel	
						LOAD RATING AT 15 RPM	Part No.	LOAD RATING AT 15 RPM	Part No.
.128	.434	9/32	.195	.050	6	63 LBS.	ET-02-S	89 LBS.	ET-02-C
.190	.497	11/32	.195	.050	7	73 LBS.	ET-03-S	104 LBS.	ET-03-C
.253	.559	13/32	.195	.050	8	83 LBS.	ET-04-S	119 LBS.	ET-04-C
.315	.622	15/32	.195	.050	9	94 LBS.	ET-05-S	134 LBS.	ET-05-C
.378	.689	19/32	.249	.062	6	104 LBS.	ET-06-S	149 LBS.	ET-06-C
.509	.934	23/32	.249	.062	8	139 LBS.	ET-08-S	198 LBS.	ET-08-C
.628	1.122	7/8	.342	.093	6	170 LBS.	ET-10-S	243 LBS.	ET-10-C
.753	1.247	1"	.342	.093	8	255 LBS.	ET-12-S	322 LBS.	ET-12-C
1.003	1.622	1-5/16	.437	.125	10	347 LBS.	ET-16-S	496 LBS.	ET-16-C
1.253	1.872	1-9/16	.437	.125	14	486 LBS.	ET-20-S	694 LBS.	ET-20-C

THRUST WASHERS

Oil Impregnated Bronze & Steel

STEEL-HARDENED AND GROUND

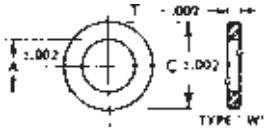

A	Bronze C	Steel C	T	Bronze Part No.	Steel Part No.
.130	.370	.250	.062	AH-1-W	AJ-1-W
.192	.495	.375	.062	AH-2-W	AJ-2-W
.255	.620	.500	.062	AH-3-W	AJ-3-W
.318	.745	.625	.093	AH-4-W	AJ-4-W
.380	.870	.750	.125	AH-5-W	AJ-5-W
.505	1.125	1.000	.187	AH-6-W	AJ-6-W

Material: Tool Steel
 Hardened and Ground RC55-60
 Bronze (Oil Impregnated)

PRECISION BRONZE BEARINGS

Oil Impregnated

PLAIN

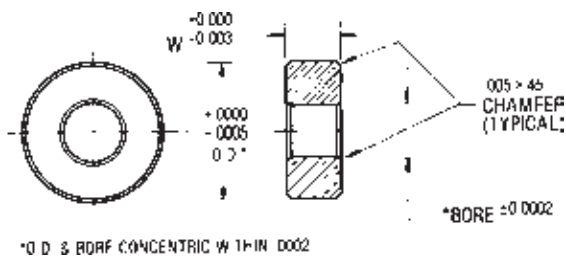

FLANGED

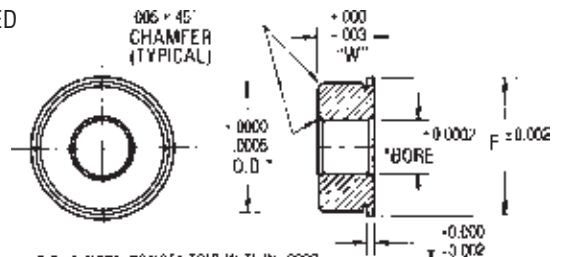

Material: Bronze ASTM B438
 Type 2, Grade 1

Bore	O.D.	W	F	T	Part No.	Plain		Flanged	
						Interchangeable with Ball Bearing Part No.	Part No.	Interchangeable with Ball Bearing Part No.	Part No.
.1250	.2500	.0937	.296	.023	AM-10	E3-5 to E3-6	AM-14	E4-5 to E4-6	
.1250	.3125	.1094	.359	.023	AM-11	E3-7 to E3-8	AM-15	E4-7 to E4-8	
.1250	.3750	.1562	.440	.030	AM-1	E1-1 to E1-3	AM-5	E2-1 to E2-3	
.1875	.5000	.1562			AM-2	E1-4			
.1875	.5000	.1960	.565	.042	AM-3	E1-5 to E1-6	AM-6	E2-4 to E2-6	
.2500	.6250	.1960	.690	.042	AM-4	E1-7 to E1-9	AM-7	F2-7 to E2-9	

ROD ENDS

Nylon & Phosphor Bronze Races

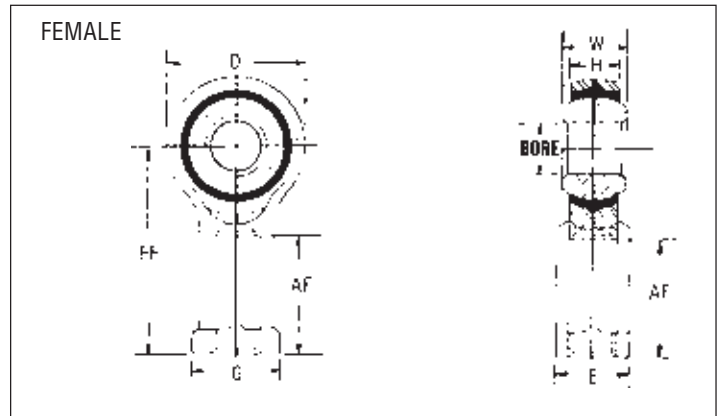
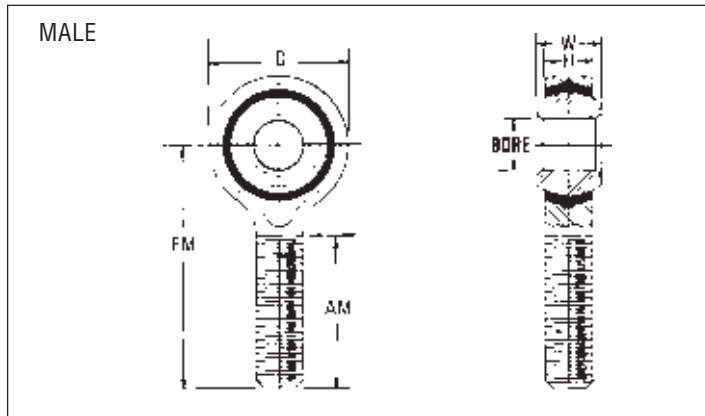

Integral Nylon Race

Materials: Housing — Mild Steel, Plated.
 Race — Nylon Integrally Molded Around The Ball.
 Ball — Case Hardened, Plated
 — Sintered Oil Impregnated Ball Available On Special
 Quotes And Orders Only

Bore	W	H	AM	FM	AF	FF	D	G	E	Thread	Angle of misalignment Degrees	Ultimate Radial Static Load Rating (lbs.)					
												PART NUMBER		Male	Female		
												PART NUMBER					
		MALE		FEMALE													
		RH	LH	RH	LH												
+ .0025 - .0065	± .005 (Ref.)	± .062	± .030	± .036	± .030	+ 6°D	(Ref.)	(Ref.)	Class UNF-2			Male	Female	RH	LH	RH	LH
.1900	.312	.250	.750	1.250	.562	1.062	.625	.406	.312	10-32	24	1150	1700	PE3-1	PE4-1	PE5-1	PE6-1
.2500	.375	.291	1.000	1.562	.750	1.312	.750	.468	.375	1/4-28	28	1600	1550	PE3-2	PE4-2	PE5-2	PE6-2
.3125	.437	.344	1.250	1.875	.750	1.375	.875	.500	.437	5/16-24	24	2700	2800	PE3-3	PE4-3	PE5-3	PE6-3
.3750	.500	.406	1.250	1.938	.937	1.625	1.000	.687	.562	3/8-24	22	3200	3250	PE3-4	PE4-4	PE5-4	PE6-4
.5000	.625	.500	1.500	2.438	1.187	2.125	1.312	.875	.750	1/2-20	20	5800	6400	PE3-5	PE4-5	PE5-5	PE6-5

*Ultimate static load in lbs.

Phosphor Bronze Race

Materials: Housing — Mild Steel, Cadmium Plated.
 Race — Sintered Phosphor Bronze Oil Impregnated
 Ball — Case Hardened Carbon Steel, Tin-Nickel Plated

Bore	W	H	AM	FM	AF	FF	D	G	E	Thread	Angle of misalignment Degrees	Ultimate Radial Static Load Rating (lbs.)					
												PART NUMBER		Male	Female		
												PART NUMBER					
		MALE		FEMALE													
		RH	LH	RH	LH												
+ .0025 - .0005	± .005 (Ref.)	± .062	± .030	± .036	± .030	± .030	± .010 (Ref.)	(Ref.)	(Ref.)	Class UNF-2		Male	Female	RH	LH	RH	LH
.1900	.312	.250	.750	1.250	.562	1.062	.750	.406	.312	10-32	22	1600	1800	PE13-1	PE14-1	PE15-1	PE16-1
.2500	.375	.291	1.000	1.562	.750	1.312	.750	.468	.375	1/4-28	26	2250	2300	PE13-2	PE14-2	PE15-2	PE16-2
.3125	.437	.344	1.250	1.875	.750	1.375	.875	.500	.437	5/16-24	22	2850	2900	PE13-3	PE14-3	PE15-3	PE16-3
.3750	.500	.406	1.250	1.938	.937	1.625	1.000	.687	.562	3/8-24	20	3900	4300	PE13-4	PE14-4	PE15-4	PE16-4
.5000	.625	.500	1.500	2.438	1.187	2.125	1.312	.875	.750	1/2-20	20	7400	8400	PE13-5	PE14-5	PE15-5	PE16-5

Metric Sizes Available
 Inquire for Price and Availability

SPHERICAL BEARINGS

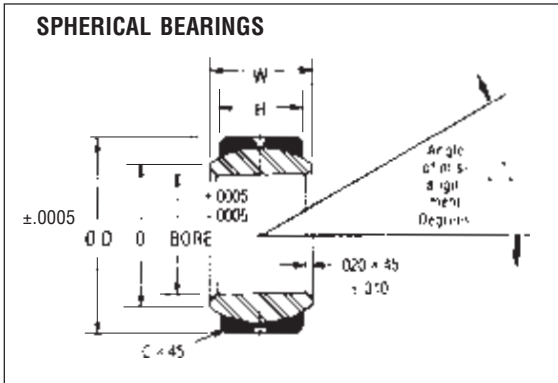

Bore	O.D.	H	W	C	Ball Dia.	Ø	Angle of 5-degree sphericity Degrees	Ultimate (Radial) Static Load Rating (lbs.)	Part No.
.1900	.5625	.218	.281	.010	.500	.416	17°	4800	PE12-1
.2500	.6562	.250	.343	.010	.594	.485	21°	7720	PE12-2
.3125	.7500	.281	.375	.020	.670	.556	18.5°	10550	PE12-3
.3750	.8125	.312	.406	.020	.718	.592	17.5°	13700	PE12-4
.5000	1.0000	.390	.500	.020	.880	.725	16.5°	22500	PE12-5

Materials: Race-Hardened Steel
Ball-Impregnated Nickel Iron

CAM FOLLOWER WITH BALL BEARINGS

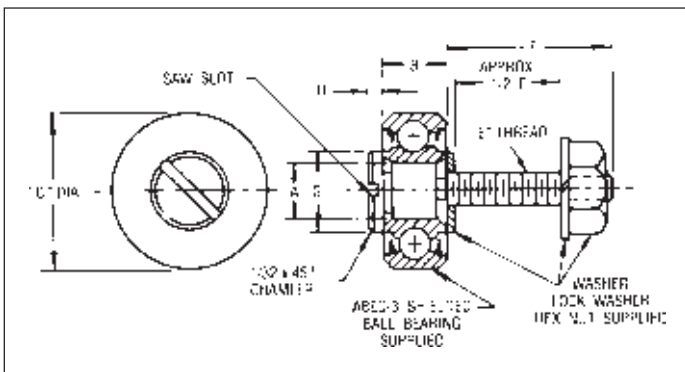

A	B	C	D	E	F	G	Part No.
.0781	.1406	.2500	3/32	#1-64	1/4	5/32	P1-21
.0937	.1406	.3125	3/32	#2-56	1/4	3/16	P1-22
.1250	.1094	.2500	1/8	#4-40	9/32	3/16	P1-23
.1250	.1406	.3125	1/8	#4-40	5/16	7/32	P1-24
.1250	.1562	.375	1/8	#4-40	5/16	1/4	P1-25
.1875	.1960	.500	5/32	#8-32	3/8	5/16	P1-26
.2500	.1960	.625	5/32	#10-32	1/2	3/8	P1-27

Material: Bearings — 440 Stainless Steel
Screw — 303 Stainless Steel
Nut & Washer — 300 Series Stainless Steel

CAM FOLLOWER WITH BRONZE BEARINGS

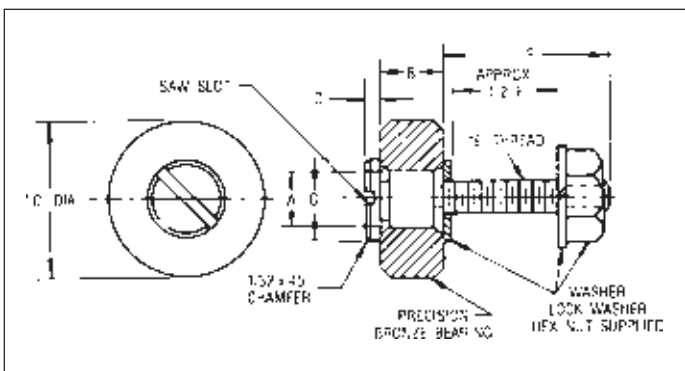

A	B	C	D	E	F	G	Part No.
.1250	.0937	.2500	1/8	#4-40	9/32	3/16	P1-23B
.1250	.1094	.3125	1/8	#4-40	5/16	7/32	P1-24B
.1250	.1562	.375	1/8	#4-40	5/16	1/4	P1-25B
.1875	.1960	.500	5/32	#8-32	3/8	5/16	P1-26B
.2500	.1960	.625	5/32	#10-32	1/2	3/8	P1-27B

Material: Bearings — Bronze, Oil Impregnated
Screw — 416 Stainless Steel
Nut & Washer — 300 Series Stainless Steel

BEARING HOUSING — 3/8", 1/2" and 5/8" Bores

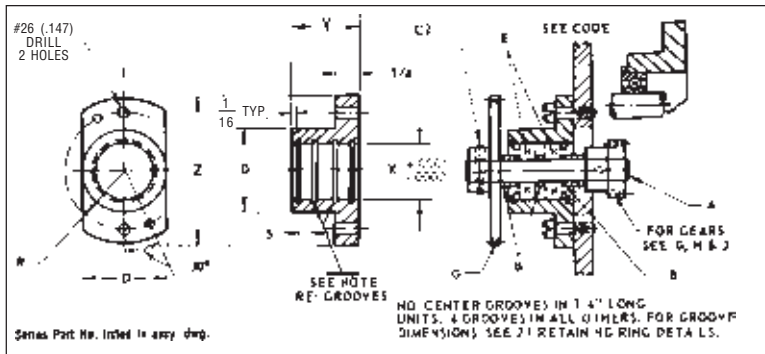

X	Y	D	Z	R	S	Part No. (Tap Holes)	Part No. (Cl. Drill)
.3750	3/4 1 1-1/2	3/4	1-1/2	.562	.187	AA1-1 AA1-2 AA1-3	AA2-1 AA2-2 AA2-3
.5000	3/4 1 1-1/2	7/8	1-5/8	.625	.260	AA3-1 AA3-2 AA3-3	AA4-1 AA4-2 AA4-3
.6250	3/4 1 1-1/2	15/16	1-3/4	.687	.260	AA5-1 AA5-2 AA5-3	AA6-1 AA6-2 AA6-3

Material: Aluminum

Finish: Anodized

Above assembly drawing depicts a common usage with PIC parts. Consult Series Index for description of parts shown.

See Section 3 for alternate Bearing Housings

BEARING MOUNTING PLATE

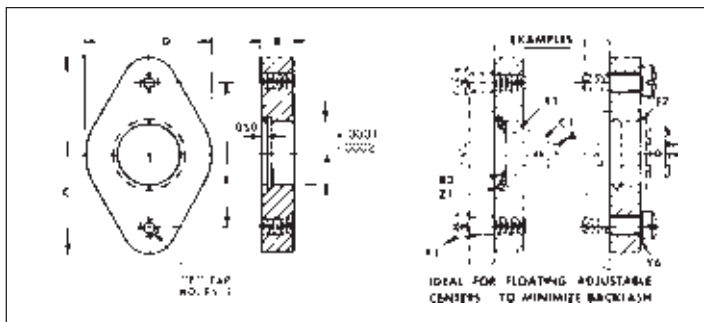

Shaft Size	A	B	C	D	E	F Holes	Part No.
						Tap	
1/4	.6250	.312	1-3/4	1	1.375	#6-32	AP-3

Material: Aluminum

Finish: Anodized

See Section 3 for alternate Bearing Housings

WAVE SPRING WASHERS

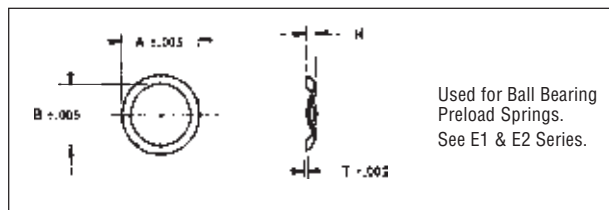

Material: 300 Series Stainless Steel - spring tempered, except where noted with "*" it is high carbon steel

Note: A and B dimensions shown in above diagram indicate blank size before forming.

A	B	T	H (Aprox.)	H ₁ (Aprox.)	Load in Lbs. H Deflected to H ₁ (Aprox.)	Part No.
.367	.265	.006	.030	.015	2-4	D6-1
.492	.350	.007	.035	.020	3-5	D6-2
.618	.440	.008	.040	.025	3-5	D6-4
.734	.531	.009	.050	.030	4-7	D6-5
.855	.650	.010	.060	.030	4-7	D6-6
1.102 *	.856	.012	.075	.037	9-13	D6-7
1.351	1.051	.015	.099	.049	16-20	D6-8
1.543 *	1.201	.017	.105	.053	19-23	D6-9
1.819 *	1.404	.020	.125	.062	26-34	D6-10
2.028 *	1.575	.022	.140	.069	31-39	D6-11
2.420 *	1.872	.022	.168	.082	40-50	D6-12

DOUBLE SHAFT HANGER / BEARING HOUSING

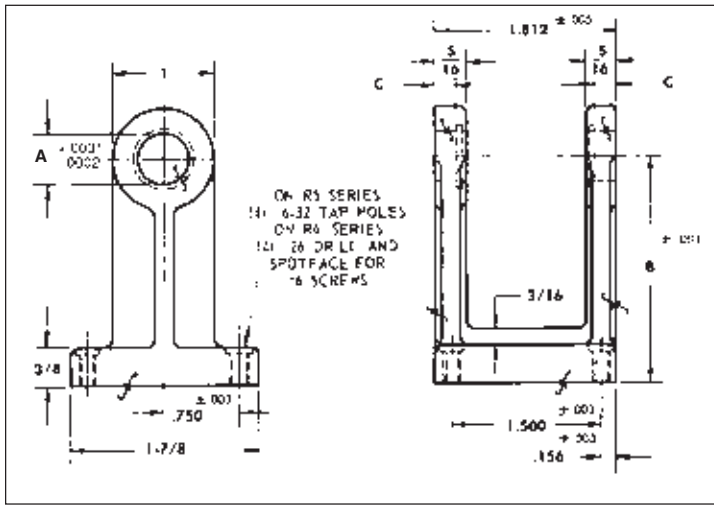

Material: Aluminum
Finish: Anodized

Shaft Size Bearing I.D.	A	B	C	Part No. (Tap Holes)	Part No. (Clearance Holes)
1/8	.3750	1.000	3/16	R5-1	R6-1
		1.500		R5-2	R6-2
		2.000		R5-3	R6-3
		2.250		R5-4	R6-4
		2.500		R5-5	R6-5
3/16	5000	1.000	7/32	R5-6	R6-6
		1.500		R5-7	R6-7
		2.000		R5-8	R6-8
		2.250		R5-9	R6-9
		2.500		R5-10	R6-10
1/4	.6250	1.000	7/32	R5-11	R6-11
		1.500		R5-12	R6-12
		2.000		R5-13	R6-13
		2.250		R5-14	R6-14
		2.500		R5-15	R6-15

See E Series for Ball Bearings, AM Series for Oil Impregnated Bearings and Z Series for Retaining Rings
See R1 Series for Bearing and Spacer Arrangements.

See Section 3 for alternate Bearing Housings

UNIVERSAL SHAFT HANGER / BEARING HOUSING

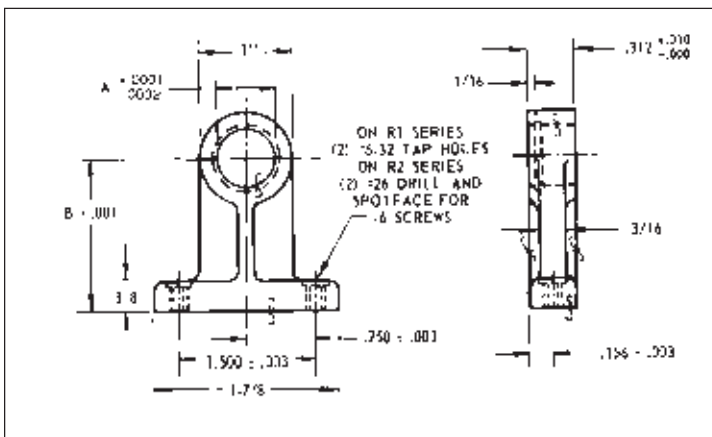

Material: Aluminum
Finish: Anodized

Shaft Size Bearing I.D.	A	B	Part No. (Tap Holes)	Part No. (Clearance Holes)	
1/8	.3750	1.000		R1-1	R2-1
		1.500		R1-2	R2-2
		2.000		R1-3	R2-3
		2.250		R1-13	R2-13
		2.500		R1-4	R2-4
3/16	5000	1.000		R1-5	R2-5
		1.500		R1-6	R2-6
		2.000		R1-7	R2-7
		2.250		R1-14	R2-14
		2.500		R1-8	R2-8
1/4	.6250	1.000		R1-9	R2-9
		1.500		R1-10	R2-10
		2.000		R1-11	R2-11
		2.250		R1-15	R2-15
		2.500		R1-12	R2-12

See Section 3 for alternate Bearing Housings

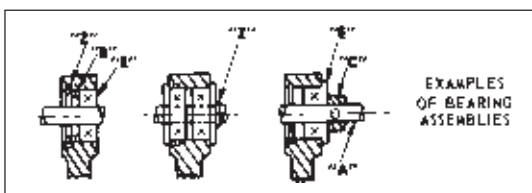

OUTER RACE SHIM SPACERS

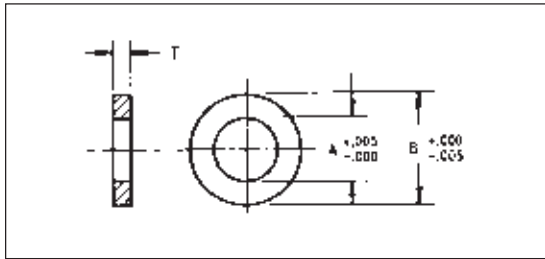

Material: 300 Series Stainless Steel

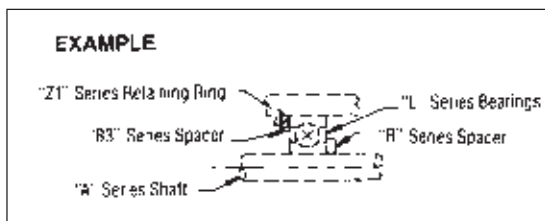

Bearing Size (Ref.) I.D. X O.D.	A	B	T	Part No.
3/64 X 5/32	.088	.153	.003	B3-39
			.005	B3-40
			.007	B3-41
			.010	B3-42
			.020	B3-43
.055 X 3/16	.123	.178	.003	B3-44
			.005	B3-45
			.007	B3-46
			.010	B3-47
			.020	B3-48
5/64 X 1/4 & 1/8 X 1/4	.167	.248	.003	B3-31
			.005	B3-32
			.007	B3-33
			.010	B3-34
			.020	B3-49
3/32 X 5/16 & 1/8 X 5/16	.206	.310	.003	B3-35
			.005	B3-36
			.007	B3-37
			.010	B3-38
			.020	B3-50
1/8 X 3/8 & 3/16 X 3/8	.253	.373	.003	B3-1
			.005	B3-2
			.007	B3-3
			.010	B3-4
			.020	B3-5
			.062	B3-16
			.125	B3-17
			.250	B3-18
			.375	B3-19
			.500	B3-20

Bearing Size (Ref.) I.D. X O.D.	A	B	T	Part No.
3/16 X 1/2 & 1/4 X 1/2	.378	.498	.003	B3-5
			.005	B3-7
			.007	B3-8
			.010	B3-9
			.020	B3-10
			.062	B3-21
			.125	B3-22
1/4 X 5/8	.503	.623	.003	B3-11
			.005	B3-12
			.007	B3-13
			.010	B3-14
			.020	B3-15
			.062	B3-26
			.125	B3-27
3/8 X 7/8	.687	.873	.003	B3-51
			.005	B3-52
			.007	B3-53
			.010	B3-54
			.020	B3-55
			.062	B3-56

OUTER RACE KITS			
Bearing Shim Spacers—Stainless Steel Outer Race Assortment Thickness for 1/8", 3/16" & 1/4" Bearing Bores	350	Y28K	

THICKNESS TOLERANCES			
T	.003 to .007	.010 to .020	.062 to .500
Tolerance	± .0005	± .001	± .002

METRIC OUTER RACE SHIM SPACERS

All Dimensions in Millimeters

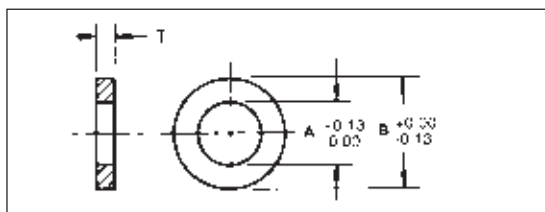

Material: 300 Series Stainless Steel

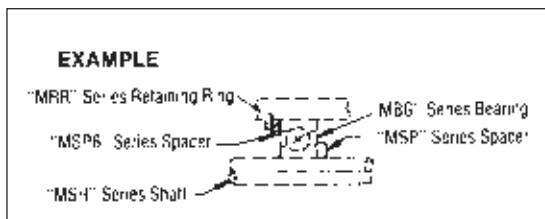

Bearing Size (Ref.) I.D. X O.D.	A	B	T	Part No.
3 X 7	5	6.95	0.1	MSP6-1
			0.25	MSP6-2
			0.5	MSP6-3
			1.5	MSP6-4
4 X 9	6.5	8.95	0.1	MSP6-5
			0.25	MSP6-6
			0.5	MSP6-7
			1.5	MSP6-8
5 X 11	8	10.95	0.1	MSP6-9
			0.25	MSP6-10
			0.5	MSP6-11
			1.5	MSP6-12

Bearing Size (Ref.) I.D. X O.D.	A	B	T	Part No.
6 X 13	9.5	12.95	0.1	MSP6-13
			0.25	MSP6-14
			0.5	MSP6-15
			1.5	MSP6-16
8 X 16	12	15.95	0.1	MSP6-17
			0.25	MSP6-18
			0.5	MSP6-19
			1.5	MSP6-20
10 X 19	14.5	18.95	0.1	MSP6-21
			0.25	MSP6-22
			0.5	MSP6-23
			1.5	MSP6-24

THICKNESS TOLERANCES				
Thickness (T)	0.1	0.25	0.5	1.5
Tolerance	± 0.013	± 0.025	± 0.025	± 0.05

INNER RACE SHAFT SPACERS — 3/32" To 1/2" Bores

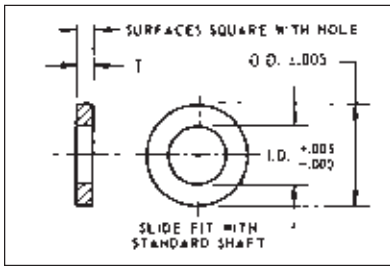

Material: 300 Series Stainless Steel

Shaft	I.D.	O.D.
5/64	.078	.164
3/32	.093	.203
1/8	.125	.187
3/16	.188	.250
1/4	.250	.375
5/16	.313	.500
3/8	.375	.562
1/2	.500	.750

T	Tolerance
.002 to .008	+ .0005
.010 to .016	+ .001
.031 to .500	+ .002

T	5/64" Spacer Part No.	3/32" Spacer Part No.	1/8" Spacer Part No.	3/16" Spacer Part No.	1/4" Spacer Part No.	5/16" Spacer Part No.	3/8" Spacer Part No.	1/2" Spacer Part No.
.002	B8-23	B6-23	B4-23	B5-24	B8-24	B14-23	B12-23	B15-23
.004	B8-16	B6-16	B4-1	B5-1	B8-1	B14-16	B12-1	B15-16
.006	B8-17	B6-17	B4-2	B5-2	B8-2	B14-17	B12-2	B15-17
.008	B8-18	B6-18	B4-3	B5-3	B8-3	—	B12-3	—
.010	B8-19	B6-19	B4-4	B5-4	B8-4	B14-19	B12-4	B15-19
.012	B8-20	B6-20	B4-5	B5-5	B8-5	B14-20	B12-5	B15-20
.014	B8-21	B6-21	B4-6	B5-6	B8-6	B14-21	B12-6	B15-21
.016	B8-22	B6-22	B4-7	B5-7	B8-7	B14-22	B12-7	B15-22
.031	—	—	B4-8	B5-8	B8-8	B14-24	B12-8	B15-24
.063	—	—	B4-9	B5-9	B8-9	B14-25	B12-9	B15-25
.094	—	—	B4-10	B5-10	B8-10	—	B12-10	—
.125	—	—	B4-11	B5-11	B8-11	—	B12-11	—
.188	—	—	B4-12	B5-12	B8-12	—	B12-12	—
.250	—	—	B4-13	B5-13	B8-13	—	B12-13	—
.375	—	—	B4-14	B5-14	B8-14	—	B12-14	—
.500	—	—	B4-15	B5-15	B8-15	—	B12-15	—

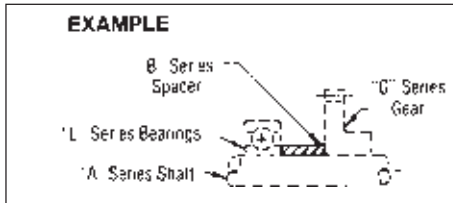

INNER RACE KITS		
Bearing Shaft Spacers—Stainless Steel	350	Y27K
Inner Race Assorted Thicknesses for 1/8", 3/16" & 1/4" Shaft Sizes		

METRIC INNER RACE SHAFT SPACERS — 3, 4, 6 & 10 mm Bores

All Dimensions in Millimeters

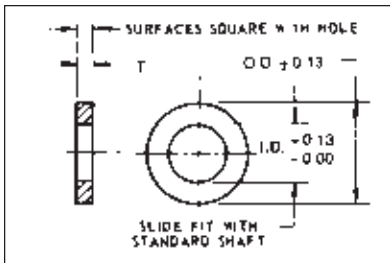

Material: 300 Series Stainless Steel

Shaft Size	Spacer	
	Inside Dia.	Outside Dia.
3	3.05	5
4	4.05	6
6	6.05	10
10	10.05	14

T	Tolerance
0.05 to .20	±0.013
0.25 to .40	±0.025
0.63 to 1.0	±0.050

T	3 Shaft Spacer Part Number	4 Shaft Spacer Part Number	5 Shaft Spacer Part Number	10 Shaft Spacer Part Number
0.05	MSP1-1	MSP2-1	MSP3-1	MSP4-1
0.10	MSP1-2	MSP2-2	MSP3-2	MSP4-2
0.15	MSP1-3	MSP2-3	MSP3-3	MSP4-3
0.20	MSP1-4	MSP2-4	MSP3-4	MSP4-4
0.25	MSP1-5	MSP2-5	MSP3-5	MSP4-5
0.30	MSP1-6	MSP2-6	MSP3-6	MSP4-6
0.35	MSP1-7	MSP2-7	MSP3-7	MSP4-7
0.40	MSP1-8	MSP2-8	MSP3-8	MSP4-8
0.60	MSP1-9	MSP2-9	MSP3-9	MSP4-9
1.00	MSP1-10	MSP2-10	MSP3-10	MSP4-10
2.00	MSP1-11	MSP2-11	MSP3-11	MSP4-11
3.00	MSP1-12	MSP2-12	MSP3-12	MSP4-12
4.50	MSP1-13	MSP2-13	MSP3-13	MSP4-13
6.00	MSP1-14	MSP2-14	MSP3-14	MSP4-14
10.00	MSP1-15	MSP2-15	MSP3-15	MSP4-15
12.00	MSP1-16	MSP2-16	MSP3-16	MSP4-16

Special Spacers Available, Consult Factory

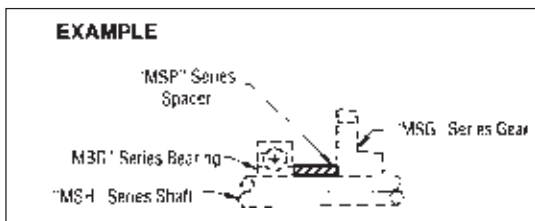

LAMINATED BRASS SHIM SPACERS

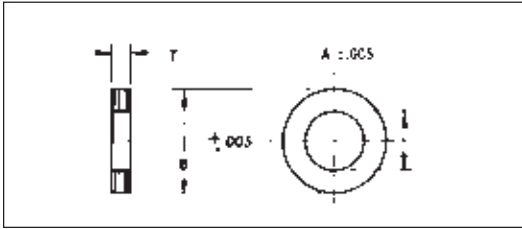

Material: Laminated Brass Shims (.002 Lamination)

Shaft Size	Type	A	B	T	Part No.
1/8	Outer Race	.312	.370	1/32	B1-1
3/16	Bearing	.375	.498		B1-2
1/4	Spacer	.437	.623		B1-3
3/8	(See Note)	.687	.873		B1-4
1/8	Shaft Spacer	.135	.234	1/32	B2-1
3/16		.193	.375		B2-2
1/4		.255	.500		B2-3
3/8		.380	.620		B2-4

NOTE: B1 SERIES DD TOLERANCE +.000
-.005

PRECISION BALLS — Inch and Metric

Stainless Steel & Nylon

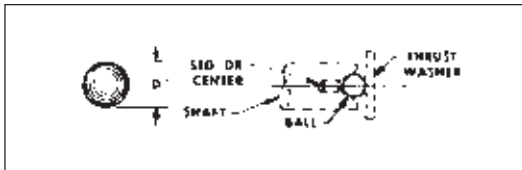

Material: 440 Stainless Steel, Grade #25
Hardened to RC55-60
Sphericity .000025
Zytel 101 Nylon
Sphericity .001

Nylon		Stainless Steel	
.0937	AL-1	.06250	AK-1
.1250	AL-2	.09375	AK-2
.1562	AL-3	.12500	AK-3
.1875	AL-4	.15625	AK-4
.2187	AL-5	.18750	AK-5
.2500	AL-6	.25000	AK-6
.3750	AL-7	.31250	AK-7
.5000	AL-8	.37500	AK-8
.5000		.50000	AK-9

METRIC Stainless Steel	
1.5000	MBL1-1
2.5000	MBL1-2
3.0000	MBL1-3
4.0000	MBL1-4
5.0000	MBL1-5
6.0000	MBL1-6
± .0013	

All Dimensions in Millimeters

PRECISION SET SCREW COLLARS

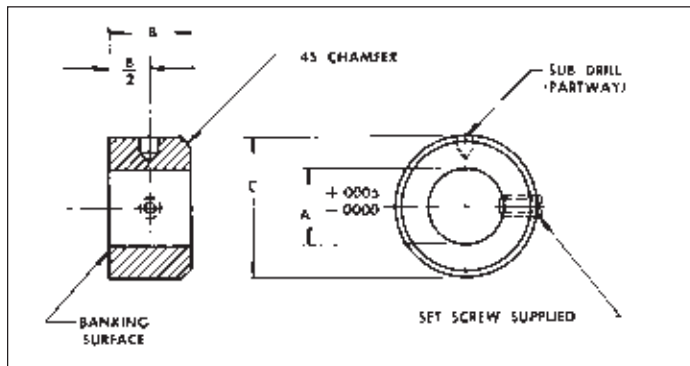

Material: 303 Stainless Steel

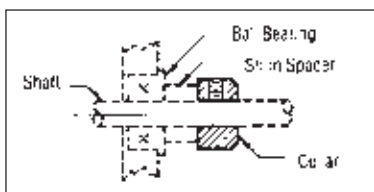

Shaft Size	A	B	C	Set Screw	Part No.
3/32	.0935	.12	1/4	# 0-80	C1-8
1/8	.1248	.18	5/16	* 2-56	C1-1
5/32	.1560	.18	5/16	ø 2-56	C1-5
3/16	.1873	.22	3/8	ø 4-40	C1-2
1/4	.2498	.25	1/2	ø 6-32	C1-3
5/16	.3123	.28	9/16	ø 6-32	C1-9
3/8	.3748	.37	3/4	#10-32	C1-10
1/2	.4998	.50	1	1/4-20	C1-11

Dimensions Below Are In Millimeters

Shaft Size	A	B	C	Set Screw	Part No.
3	2.995	4.57	7.9	M2X.4	MSC1-1
4	3.995	5.59	9.5	M2X.4	MSC1-2
5	4.995	5.59	9.5	M3X.5	MSC1-3
6	5.995	6.35	12.7	M3X.5	MSC1-4
8	7.995	7.11	14.3	M3X.5	MSC1-5
10	9.995	9.4	19.1	M5X.8	MSC1-6
12	11.995	12.7	25.4	M6X.1	MSC1-7

Special Collars Available. Consult Factory.
For "No-Mar" Set Screws See CS Series

CLAMPS - SPLIT & SCREW TYPES — 1/8" To 1/2" Shaft Size

SPLIT TYPE

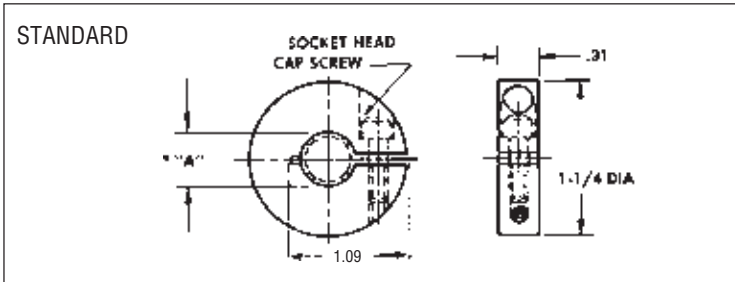

Ref. Gear Bore	*A +.001 -.000	Part Number
5/16	.375	L1-20
3/8	.437	L1-21
1/2	.562	L1-22

Material: 303 Stainless Steel
Clearance radius .63

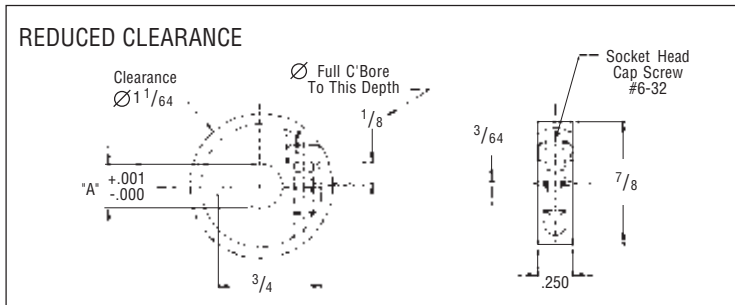

Ref. Gear Bore	*A +.001 -.000	Part Number
1/8	.188	L4-1
3/16	.250	L4-2
1/4	.313	L4-3

Also available in Aluminum, Consult Factory

Material: 303 Stainless Steel
Clearance radius .508

SCREW TYPE

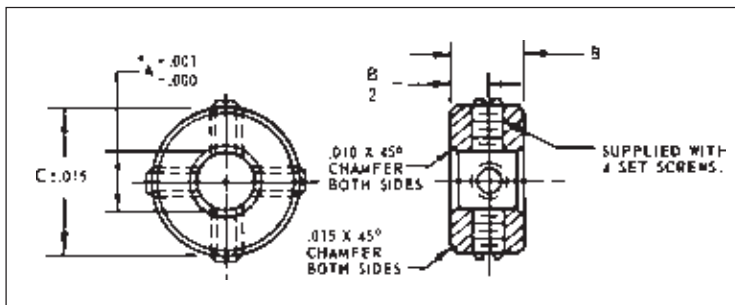

*NOTE: "A" diameter is O.D. of split hub gear or sprocket hub & is I.D. of clamp.

Ref. Gear Bore	*A +.001 -.000	A	C	Set Screws	Part Number
1/8	.188	.25	.37	#4-40	L4-13
3/16	.250	.25	.50	#6-32	L4-14
1/4	.313	.25	.50	#6-32	L4-15

Also available in Aluminum, Consult Factory

Material: 303 Stainless Steel

ADJUSTABLE HUB CLAMP

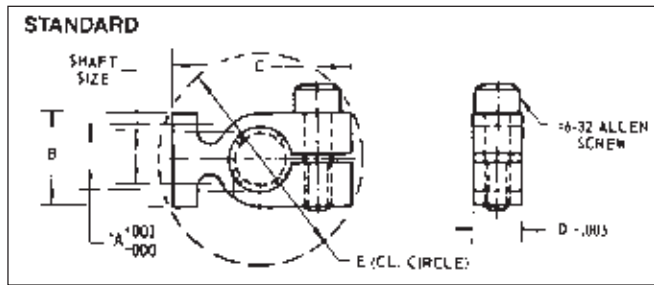

Material: 416 Stainless Steel — Heat Treated RC38-45

Ref. Gear Bore	*A	B	C	D	E	Finish	Part No.
1/8	.188	5/16	11/16	240	7/8	Black Passivate	L1-1
3/16	.250	3/8	13/16		1-1/32		L1-2
1/4	.312	7/16	13/16		1-1/8		L1-3
1/8	.188	5/16	11/16	240	7/8	Clear Passivate	L1-4
3/16	.250	3/8	13/16		1-1/32		L1-5
1/4	.312	7/16	13/16		1-1/8		L1-6

*NOTE: "A" diameter is O.D. of split hub gear or sprocket hub & is I.D. of clamp.

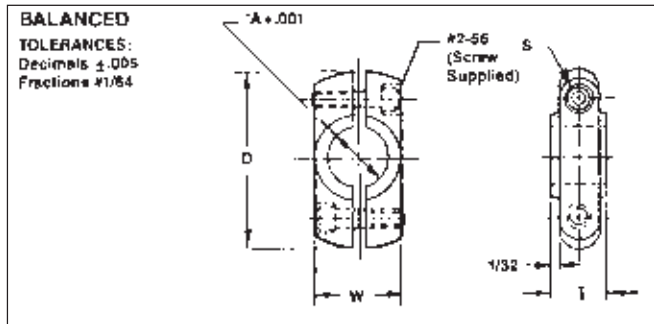

Material: 416 Stainless Steel — Heat Treated RC38-45

Ref. Gear Bore	*A	D	T	W	Type Balance	Part No.
1/8	.188	23/32	240	5/16	As Machined	L1-7
3/16	.250	3/4	240	3/8		L1-8
1/4	.312	7/8	240	7/16		L1-9

Dynamically balanced units available on request. Consult Factory

ADJUSTABLE HUB CLAMP — .188" To .438" Bores

Miniature

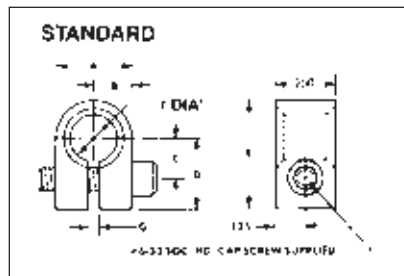

Material: 303 Stainless Steel
416 Stainless Steel Available on Request, Consult Factory

Ref. Gear Bore	F Dia. ±.0005	A	B	C	D	E	G	Part No.
1/8	.188	.312	.156	.187	312	15/32	.031	L5-1
3/16	.251	.375	.188	.256	375	9/16	.046	L5-2
1/4	.313	.437	.218	.250	375	19/32	.046	L5-3
5/16	.376	.500	.250	.281	406	21/32	.046	L5-4
3/8	.438	.625	.312	.343	468	25/32	.046	L5-5

*NOTE: "F" diameter is O.D. of split hub gear or sprocket hub & is I.D. of clamp.

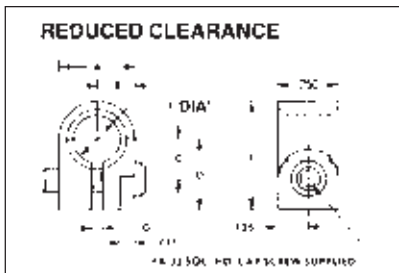

Material: 303 Stainless Steel
416 Stainless Steel Available on Request, Consult Factory

Ref. Gear Bore	F Dia. ±.0005	A	B	C	D	E	G	Part No.
1/8	.188	.312	.156	.187	312	15/32	.031	L6-1
3/16	.251	.375	.188	.256	375	9/16	.046	L6-2
1/4	.313	.437	.218	.250	375	19/32	.046	L6-3
5/16	.376	.500	.250	.281	406	21/32	.046	L6-4
3/8	.438	.625	.312	.343	468	25/32	.046	L6-5

SHAFT EXTENSIONS

1/4", 3/8" Bores

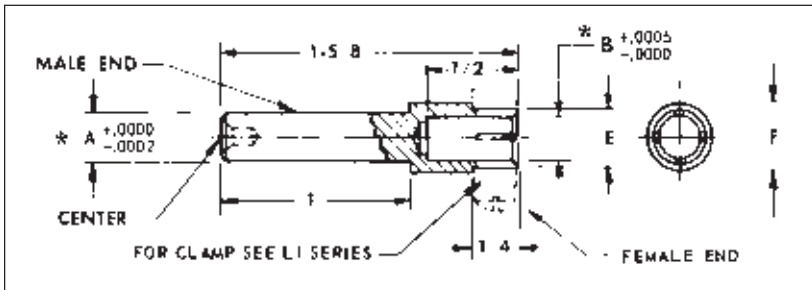

Material: 303 Stainless Steel

Shaft Size	A*	B**	E	F	Part No.
Male to Female					
1/4 to 1/4	2497	2498	.312	.375	AU-3
3/16 to 1/4	.1872	2498	.312	.375	AU-6
1/4 to 1/8	2497	1248	.188	.250	AU-8
1/4 to 3/8	2497	3748	.437	.500	AU-11
3/8 to 1/4	3747	2498	.312	.375	AU-12

*Inch Shaft Dia. Toler. $\begin{matrix} +.0000 \\ -.0002 \end{matrix}$

**Inch Bores Toler. $\begin{matrix} +.0005 \\ -.0000 \end{matrix}$

*Diameters Concentric Within .0005 T.I.R.

STAINLESS THREADED STOCK — #2-56 To 3/8 -16

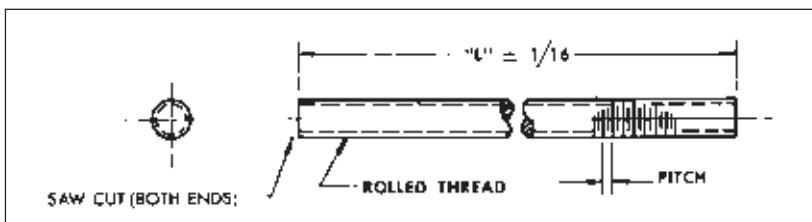

Material: 300 Series Stainless Steel

Thread	D	Pitch	L	Part No.
* 2-56	.086	.018	12	A9-10
* 4-40	.112	.025		A9-11
* 6-32	.138	.031		A9-1
* 8-32	.164	.031	16	A9-2
* 10-32	.190	.031		A9-4
1/4 -20	1/4	.050		A9-5
1/4 -28	1/4	.036	24	A9-8
5/16 -8	5/16	.056		A9-7
3/8 -16	3/8	.062		A9-8

Other Lengths, Diameters and Modifications Available.
Consult Factory

STAINLESS THREADED STUDS — #6-32 To 1/4 -20

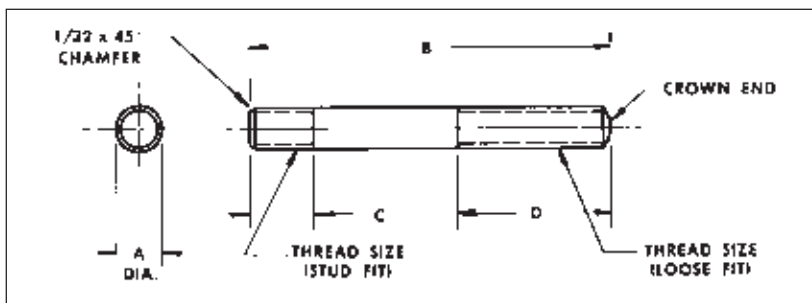

Material: 303 Stainless Steel

Thread Size	A	B	C	D	Part No.
#6-32	.138	1	7/32	1/2	2040
		1-1/4		5/8	2041
		1-1/2		3/4	2042
		1-3/4		3/4	2043
		2		3/4	2044
#8-32	.164	1	7/32	1/2	2045
		1-1/4		5/8	2046
		1-1/2		3/4	2047
		1-3/4		3/4	2048
		2		3/4	2049

Thread Size	A	B	C	D	Part No.
#10-32	.190	1	7/32	1/2	2055
		1-1/4		5/8	2056
		1-1/2		3/4	2057
		1-3/4		3/4	2058
		2		3/4	2059
1/4 -20	.250	1-1/4	9/32	5/8	2060
		1-1/2		5/8	2061
		1-3/4		3/4	2062
		2		3/4	2063
		2 1/2		3/4	2064
3	1	2065			

PRECISION GROUND SHAFTING — 1/32" To 1" Diameter

Nominal, Undersized and Oversized Diameters

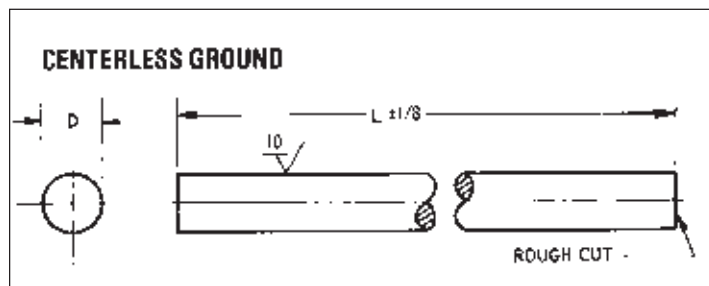

Material: 303 Stainless Steel

Diameter Tolerance	
1/32 TO 1/2	+ .0000 - .0002
5/8 TO 1	+ .0000 - .0004

Fractional Dia. (Ref.)	D	L	Part No.
1/32	.0313	12	A8-1
	.0317		A8-23
1/16	.0622	12	A8-24
	.0626		A8-2
	.0630		A8-25
5/64	.0778	12	A8-20
	.0781		A8-22
	.0786		A8-26
3/32	.0934	12	A8-21
	.0938		A8-3
	.0942		A8-27
1/8	.1247	24	A8-5
	.1250	12	A8-5
	.1251		A8-4
	.1255	24	A8-28
5/32	.1559	24	A8-29
	.1562		A8-18
	.1567		A8-30
3/16	.1872	24	A8-9
	.1875		A8-7
	.1880		A8-31
7/32	.2184	24	A8-32
	.2187		A8-19
	.2192		A8-33
1/4	.2497	24	A8-11
	.2497	36	A8-34

Fractional Dia. (Ref.)	D	L	Part No.
1/4	.2500	24	A8-10
	.2500	36	A8-35
5/16	.3122	24	A8-13
	.3125		A8-12
3/8	.3747	16	A8-15
	.3747	36	A8-38
	.3750	16	A8-14
	.3750	36	A8-39
1/2	.4997	16	A8-17
	.4997	36	A8-41
	.5000	16	A8-16
	.5000	36	A8-42
5/8	.6247	36	A8-44
	.6250		A8-45
3/4	.7497	36	A8-47
	.7500		A8-48
1	.9997	36	A8-50
	1.0000		A8-51

For Pre-Cut and Chamfered Precision Ground Shafting. See A1 Through A7 Series. Other Lengths, Diameters and Modifications Available. Consult Factory.

ULTRA PRECISION SHAFTING — 1/8", 3/16" and 1/4" Diameter

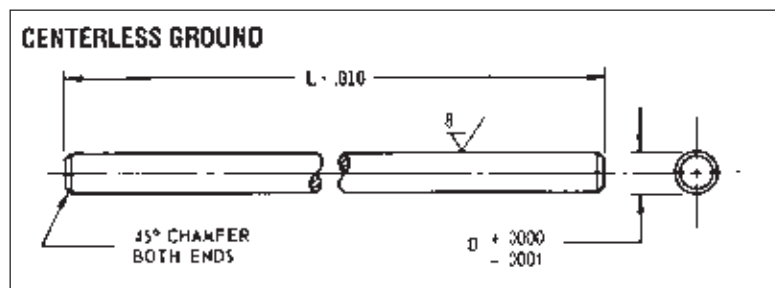

Material: 303 Stainless Steel

Diameter	D	Straightness Tolerance
1/8	.12475	.0002
3/16	.18725	.00015
1/4	.24975	.0001

L	1/8 Dia. Part No.	3/16 Dia. Part No.	1/4 Dia. Part No.
1.00	A4-10	—	—
1.12	A4-11	—	—
1.25	—	A5-12	—
1.37	A4-13	—	—
1.50	—	A5-15	A8-15
1.75	A4-17	A5-17	—
1.88	A4-18	—	—
2.00	A4-20	A5-20	A6-20
2.50	—	—	A6-25
2.75	—	—	A6-27
3.00	—	A5-30	—
3.12	—	—	A6-31
3.25	A4-32	—	—
3.50	—	—	A6-35
4.00	—	—	A6-40
4.25	—	—	A6-42

Sold in increments of 5 pcs. Other Lengths, Diameters and Modifications Available. Consult Factory.

PRECISION GROUND SHAFTING — 1/8", 3/16", 1/4", & 3/8" Diameters

Designed to fit "E" Series Ball Bearings, and "AM" Oil-Impregnated Bearings

PIC Ground Stock Shafting has been established to meet the majority of precision shaft requirements. All shaft material made of 303 Stainless Steel is ground to a 10 micro finish or better.

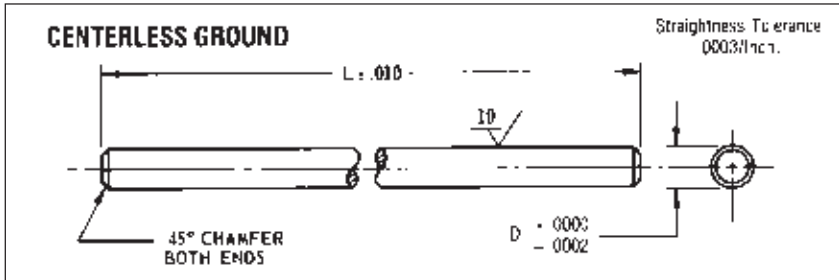

Material: 303 Stainless Steel

Dia.	D
1/8"	1247
3/16"	1872
1/4"	2497
3/8"	3747

SHAFT MODIFICATIONS

Illustrated below are standard shaft modifications available on request. For other configurations, send drawing or sketch for quotation.

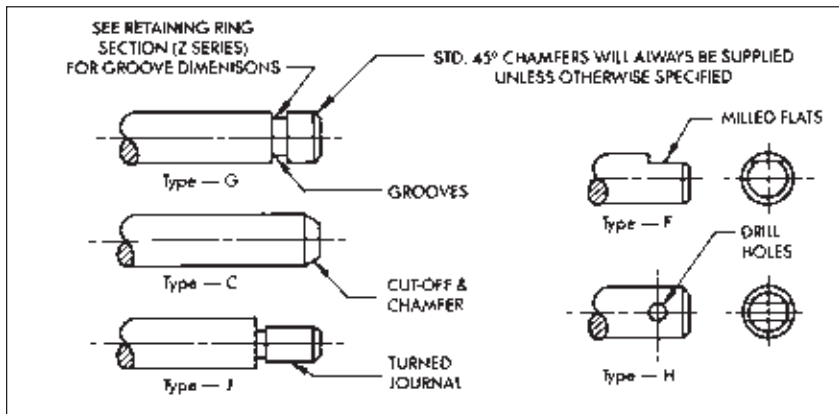

*L	1/8 Dia. Part No.	3/16 Dia. Part No.	1/4 Dia. Part No.	3/8 Dia. Part No.
1.00	A1-10	A2-10	A3-10	—
1.12	A1-11	A2-11	A3-11	—
1.25	A1-12	A2-12	A3-12	—
1.37	A1-13	A2-13	A3-13	—
1.50	A1-15	A2-15	A3-15	—
1.62	A1-16	A2-16	A3-16	—
1.75	A1-17	A2-17	A3-17	—
1.87	A1-18	A2-18	A3-18	—
2.00	A1-20	A2-20	A3-20	A7-20
2.12	A1-21	A2-21	A3-21	—
2.25	A1-22	A2-22	A3-22	A7-22
2.37	A1-23	A2-23	A3-23	—
2.50	A1-25	A2-25	A3-25	A7-25
2.62	A1-26	A2-26	A3-26	—
2.75	A1-27	A2-27	A3-27	A7-27
2.87	A1-28	A2-28	A3-28	—
3.00	A1-30	A2-30	A3-30	A7-30
3.12	A1-31	A2-31	A3-31	—
3.25	—	A2-32	A3-32	A7-32
3.37	—	A2-33	A3-33	—
3.50	A1-35	A2-35	A3-35	A7-35
3.62	—	A2-36	A3-36	—
3.75	—	A2-37	A3-37	A7-37
3.87	—	—	A3-38	—
4.00	A1-40	A2-40	A3-40	A7-40
4.12	—	—	A3-41	—
4.25	A1-42	—	A3-42	A7-42
4.37	—	—	A3-43	—
4.50	A1-45	A2-45	A3-45	A7-45
4.62	—	—	A3-46	—
4.75	—	—	A3-47	A7-47
4.87	—	—	A3-48	—
5.00	A1-50	A2-50	A3-50	A7-50
5.12	A1-51	—	A3-51	—
5.25	A1-52	A2-52	A3-52	A7-52
5.37	A1-53	—	A3-53	—
5.50	A1-55	—	A3-55	A7-55
5.62	A1-56	—	A3-56	—
5.75	A1-57	A2-57	A3-57	A7-57
5.87	—	—	A3-58	—
6.00	A1-60	A2-60	A3-60	A7-60
6.25	—	A2-62	A3-62	—
6.37	—	—	A3-63	—
6.50	—	—	A3-65	A7-65
6.62	—	—	A3-66	—
6.75	A1-67	—	—	—
7.00	—	A2-70	A3-70	—
7.50	—	A2-75	A3-75	—
8.00	—	A2-80	A3-80	A7-80
8.50	—	A2-85	A3-85	—
9.00	A1-90	—	A3-90	A7-90
9.50	—	—	A3-95	—
10.00	—	A2-100	A3-100	A7-100
11.00	—	—	—	A7-110
12.00	A1-120	A2-120	A3-120	A7-120
13.00	—	—	A3-130	—
14.00	—	—	A3-140	—
15.00	—	—	A3-150	—
16.00	A1-160	—	A3-160	A7-160
20.00	—	—	—	A7-200
24.00	—	—	—	A7-240

For Longer Lengths, See "A8" Series

* A1, A2 and A3 series, 1" thru 6" lengths, are sold in increments of 5 pcs.

Other Lengths, Diameters and Modifications Available. Consult Factory.

METRIC PRECISION GROUND SHAFTING — 3, 4, 5 & 6 mm Diameters

All Dimensions in Millimeters

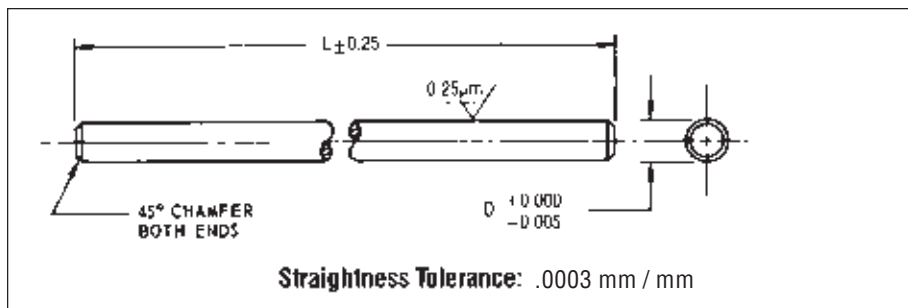

Material: 303 Stainless Steel

Diameter	D
3	2.993
4	3.993
5	4.993
6	5.993

Length	3 mm Part No.	4 mm Part No.	5 mm Part No.	6 mm Part No.
25	MSH1-1	MSH2-1	MSH3-1	MSH4-1
30	MSH1-2	MSH2-2	MSH3-2	MSH4-2
35	MSH1-3	MSH2-3	MSH3-3	MSH4-3
40	MSH1-4	MSH2-4	MSH3-4	MSH4-4
45	MSH1-5	MSH2-5	MSH3-5	MSH4-5
50	MSH1-6	MSH2-6	MSH3-6	MSH4-6
55	MSH1-7	MSH2-7	MSH3-7	MSH4-7
60	MSH1-8	MSH2-8	MSH3-8	MSH4-8
65	MSH1-9	MSH2-9	MSH3-9	MSH4-9
70	MSH1-10	MSH2-10	MSH3-10	MSH4-10
75	MSH1-11	MSH2-11	MSH3-11	MSH4-11
80	MSH1-12	MSH2-12	MSH3-12	MSH4-12
85	MSH1-13	MSH2-13	MSH3-13	MSH4-13
90	MSH1-14	MSH2-14	MSH3-14	MSH4-14
95	MSH1-15	MSH2-15	MSH3-15	MSH4-15
100	MSH1-16	MSH2-16	MSH3-16	MSH4-16
105	MSH1-17	MSH2-17	MSH3-17	MSH4-17
110	MSH1-18	MSH2-18	MSH3-18	MSH4-18
115	MSH1-19	MSH2-19	MSH3-19	MSH4-19
120	MSH1-20	MSH2-20	MSH3-20	MSH4-20
125	MSH1-21	MSH2-21	MSH3-21	MSH4-21
150	MSH1-22	MSH2-22	MSH3-22	MSH4-22
175	MSH1-23	MSH2-23	MSH3-23	MSH4-23
200	MSH1-24	MSH2-24	MSH3-24	MSH4-24
225	MSH1-25	MSH2-25	MSH3-25	MSH4-25
250	MSH1-26	MSH2-26	MSH3-26	MSH4-26

Other Lengths, Diameters and Modifications Available, Consult Factory.

METRIC PRECISION GROUND SHAFTING — 3, 4, 6, 8, 10 & 12 mm Dia.

All Dimensions in Millimeters

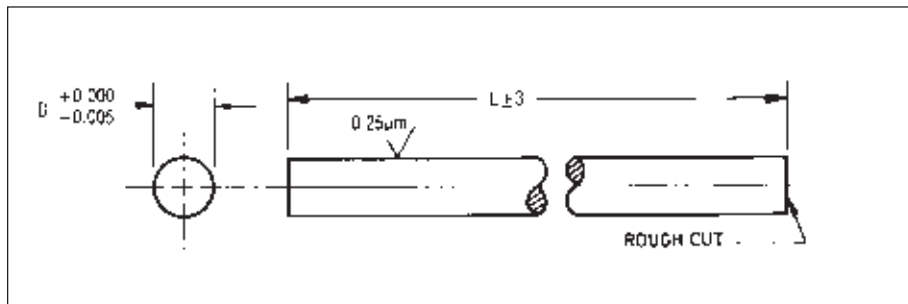

Material: 303 Stainless Steel

D	L	Part No.
2.993	600	MSH7-1
3.000		MSH7-2
3.993	600	MSH7-3
4.000		MSH7-4
5.993	600	MSH7-5
6.000		MSH7-6
7.993	600	MSH7-7
8.000		MSH7-8
9.993	1000	MSH7-9
10.000		MSH7-10
11.993	1000	MSH7-11
12.000		MSH7-12

Other Lengths, Diameters and Modifications Available, Consult Factory.

PRECISION CASE HARDENED & GROUND SHAFTING

Inch and Metric

For Linear Motion Applications

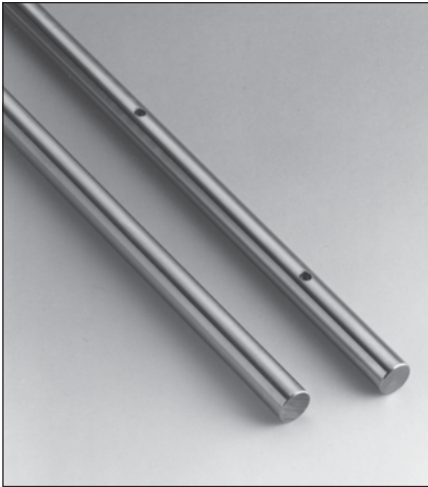

Materials and Hardness:

C-1060 steel, case hardened to Rockwell 60-65C

440 C stainless steel, case hardened to Rockwell 50-55C

303 stainless steel, (for use with engineered plastic bearings),

has approximate hardness of Rockwell 75-95B.

C-1060 can be supplied with hard satin chrome finish at additional cost. Special orders only.

(Adds .0001 to .0002 to diameter).

Finish: Normally between 10 and 16 micro-inches RMS. Other finishes can be furnished to meet special requirements.

Length Tolerances: Shafting is stocked in 6 to 10 foot lengths, and is supplied to required lengths $\pm 1/16"$ ($\pm 1.5\text{mm}$). If required, closer length tolerances can be supplied at additional cost.

Straightness: With the exception of 1/4" and 3/8" diameters, the standard straightness tolerance is .001"-.002" per foot cumulative. Straighter lengths to meet more stringent requirements can be supplied at additional cost.

Chamfered Ends: Normally, all shafts are rough cut. Precision chamfers or other dimensions are classified as a special fabrication and carry extra charges.

Maximum Lengths: The maximum lengths in stock for each diameter are shown in the tables.

HOW TO ORDER

When ordering shafts that do not require any special machining, simply add length (in inches or mm) requirement to Part Number. Example: A10-8-20".

Inch Shaft Diameters

Nominal Diameter (Inches)	Size & Tol. (Inches)	Max Length (ft)	C-1060 Steel Hardened & Ground		440 C stainless Hardened & Ground		303 Stainless Steel Ground Part No.
			Case Depth	Part No.	Case Depth	Part No.	
1/4	.2485/.2490 .2490/.2495	6	.040	A10-4 A10L-4	—	—	A11-4 —
3/8	.3735/.3740 .3740/.3745	6	.040	A10-6 A10L-6	—	—	A11-6 —
1/2	.4985/.4990 .4990/.4995	6	.060	A10-8 A10L-8	.060	A12-8 —	A11-8 —
5/8	.6235/.6240 .6240/.6245	10	.060	A10-10 A10L-10	.060	A12-10 —	A11-10 —
3/4	.7485/.7490 .7490/.7495	10	.060	A10-12 A10L-12	.060	A12-12 —	A11-12 —
1	.9985/.9990 .9990/.9995	10	.080	A10-16 A10L-16	.080	A12-16 —	A11-16 —
1 1/4	1.2485/1.2490 1.2490/1.2495	10	.080	A10-20 A10L-20	.080	A12-20 —	A11-20 —
1 1/2	1.4984/1.4989 1.4989/1.4994	10	.080	A10-24 A10L-24	.080	A12-24 —	A11-24 —

Note: L Series shafting should be used with self-aligning linear bearings.

Metric Shaft Diameters

Nominal Diameter (mm)	Tolerance μm	Max. Length (mm)	C-1060 Steel Hardened & Ground		440C Stainless Steel Hardened & Ground		303 Stainless Steel Ground Part No.
			Case Depth	Part No.	Case Depth	Part No.	
5	0/-10	700	1.0	MA10-05	1.0	MA12-05	MA11-05
8	0/-10	1500	1.0	MA10-08	1.0	MA12-08	MA11-08
12	0/-10	3000	1.0	MA10-12	1.0	MA12-12	MA11-12
16	0/-10	3000	1.5	MA10-16	1.5	MA12-16	MA11-16
20	0/-12	3000	1.5	MA10-20	1.5	MA12-20	MA11-20
25	0/-12	3000	1.5	MA10-25	1.5	MA12-25	MA11-25
30	0/-12	3000	2.0	MA10-30	2.0	MA12-30	MA11-30
40	0/-15	3000	2.0	MA10-40	2.0	MA12-40	MA11-40

SPECIAL PRECISION MACHINING

Quotations are provided after receipt of a faxed drawing, rough sketch or verbal description. Indicate quantity required.

Metric Conversion To Inches: .03937 x metric dimension

Inch Conversion To Metric: 25.4 x inch dimension

COMPONENT MTG. HANGERS

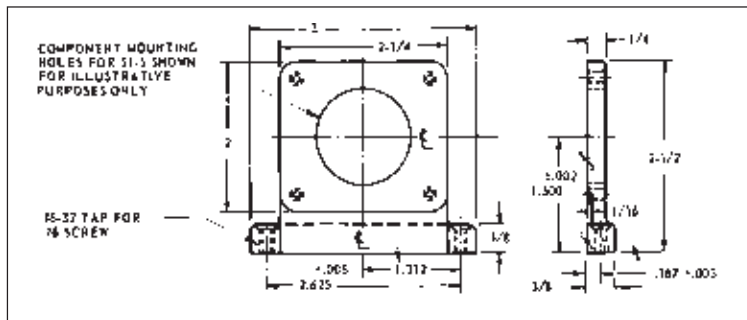

Material: Aluminum
Finish: Anodized

Part No.	Part No.
S1-1	S1-6
S1-2	S1-7
S1-3	S1-8
S1-4	S1-9
S1-5	S1-10

COMPONENT MOUNTING DATA

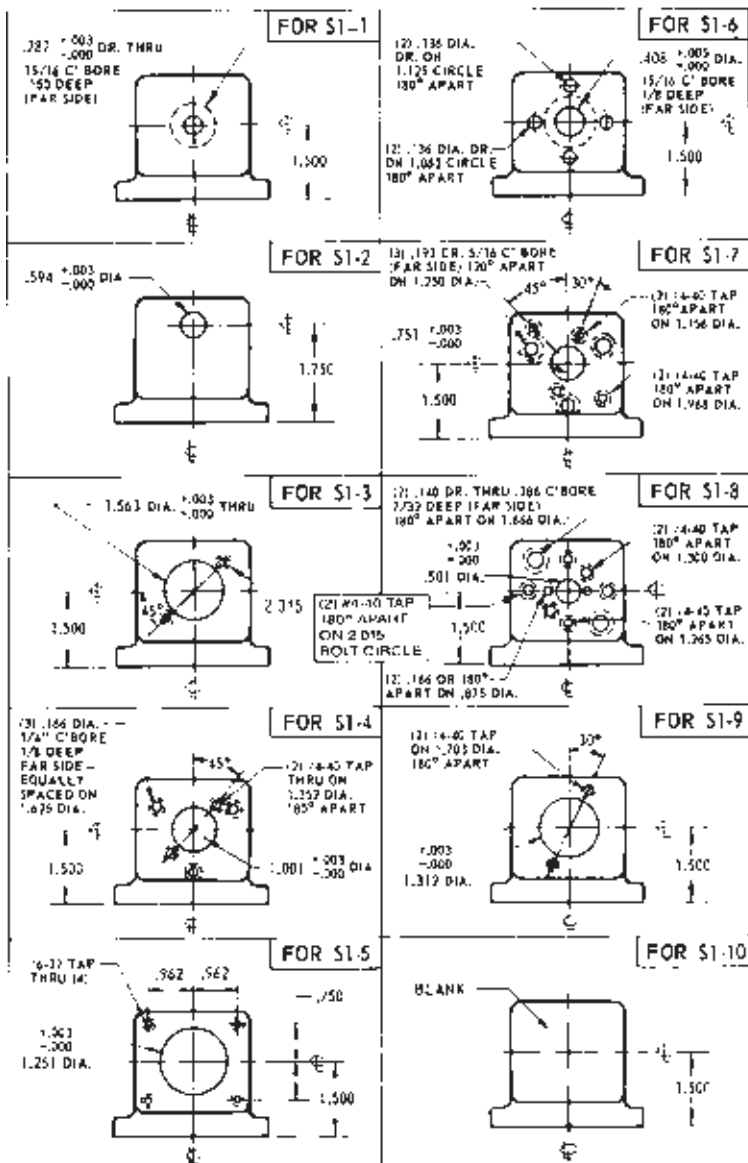

LARGE BLANK COMPONENT HANGERS

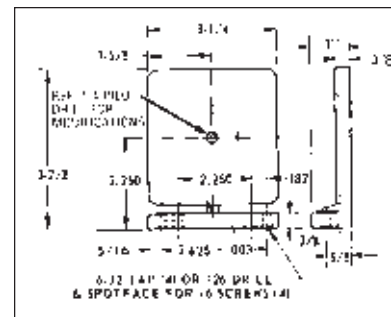

Material: Aluminum
Finish: Chromic Acid Anodize

Part No. (Tap Hole)	Part No. (Clearance Hole)
S3-1	S4-1

PIC will modify any series hanger for special rotating components on request.

CLUTCHES, BRAKES & COUPLINGS

1. Clutch
2. Power on Brake
3. Power off Brake
4. Slip Clutch Assembly
5. Slip Coupling
6. Zero Adjustable Coupling
7. Bellows Coupling
8. Miniature Oldham Coupling
9. Multi-Jaw Coupling
10. Flexible Coupling
11. Water Spring Coupling
12. Universal Lateral Coupling
13. Molded Universal Joint
14. Precision Universal Joint
15. Roller Clutch

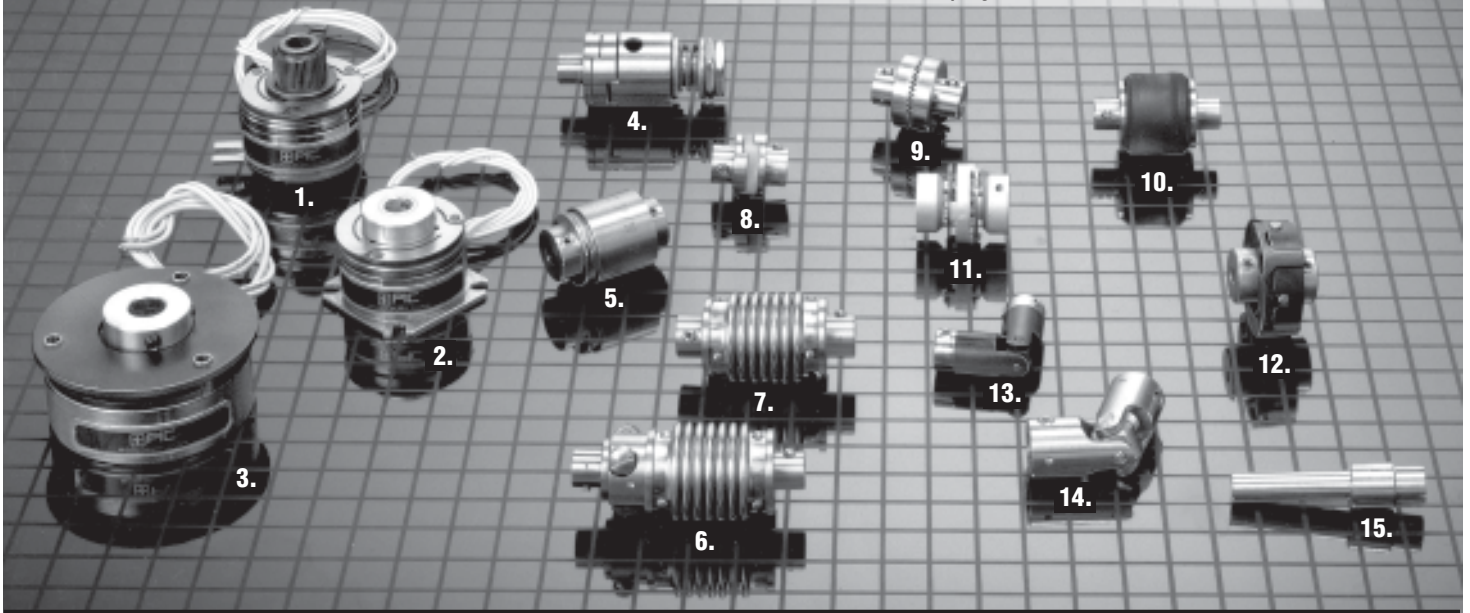

Whatever type of clutch, brake or coupling your application requires, you can be most assured of finding it quickly and easily among the comprehensive assortment of such components available from PIC Design...one that includes a complete selection of electro-magnetic clutches and brakes and mechanical slip clutches and couplings.

**PIC Design Clutches, Brakes and Couplings—
 A Brief Overview**

ELECTRIC CLUTCHES AND BRAKES

The PIC line comprises both shaft-mounted clutches and flange-mounted power-on and power-off brakes, all highly suited to situations in which an immediate response is required in either start or stop functions of driving mechanisms. The variety of voltages and bore sizes offered is aimed at giving designers and engineers especially easy access to precise components needed for such applications as copier drives, tape and film drives and packaging machines.

SERVO ELECTRIC CLUTCHES AND BRAKES

These units consist of miniature precision electro-magnetic clutches and brakes designed for use in

military/aerospace applications and precision servo mechanisms. Each is available with a servo mounting flange and with one or two output shafts.

SLIP CLUTCHES

These stainless steel mechanical clutches come precision-calibrated and spring-wrapped, and are designed to accommodate the mounting of input gears, sprockets or pulleys. Slip torque is stable and independent of velocity, regardless of rotational direction.

ROLLER CLUTCHES

The roller clutches are used to transmit torque between the shaft and housing in one direction and allows free overrun in the opposite direction. The clutches are generally used in applications requiring indexing, backstopping, or overrunning.

SLIP COUPLINGS

These devices not only serve as couplings for two colinear shafts, but also as a torque limiter. When the load exceeds the limit torque of a slip coupling, the two shafts will rotate relative to each other at the full limit torque.

COUPLINGS

The designs and styles listed below are suitable for a wide array of applications; for example, a design requiring the connection of two in-line shafts of equal or unequal diameters measured either in inches or millimeters.

- Bellows Couplings
- Zero Adjustable Couplings
- Flexible Couplings
- Miniature Oldham Couplings
- Wafer Oldham Couplings
- Universal Lateral Couplings
- Multi-Jaw Couplings
- Precision Universal Joint Couplings
- Molded Universal Joint Couplings
- Precision Sleeve Couplings
- Flexible Zero Backlash Couplings
- Spider Coupling

Assistance in determining which coupling best fills your particular requirements is provided in the technical section that follows.

TECHNICAL SECTION

Industrial Clutches and Brakes

Clutches in this category are utilized in applications involving a driving shaft which, when rotating, is able to engage or disengage a secondary shaft driven either by gears or a belt-and-pulley combination. Industrial brakes are intended for applications in which the primary mover is to be held at its stop position. A power-on brake will decelerate and provide inertia when power is supplied, requiring that power be transferred from motor to brake. A power-off brake is energized along with the motor itself, decelerating and retaining inertia when the power is shut off. The latter is geared to applications where power consumption and safety are of major concern.

PIC Design clutches and brakes can perform any of the following functions for a variety of applications similar to the ones listed below:

Functions	Applications
Remote Coupling	Copier Paper Drives
Instant Reversing	Computer Disc Drives
Speed Changing	Card Feeders
Torque Limiting	Collators
Rapid Cycling	Money Dispensers
Indexing	Teletype Machines
Jogging	X-Ray Table Drives
Tensioning	Blood Gas Analyzers
Cushioned Starts & Stops	Ticket Dispensers

BURNISHING

Burnishing is a wearing in or mating process used to ensure the highest possible output torques. It is accomplished by forcing the clutch or brake to slip rotationally when energized. Best results are obtained when the unit is energized at 30-40% of rated voltage and forced to slip for a period of 2-3 minutes at a low speed of 100-200 rpm. Units in applications involving high inertial loads and speed will usually become burnished in their normal operating mode. Whenever possible, it is desirable to perform the burnishing operation in the final location so the alignment of the burnished faces will not be disturbed.

CYCLE LIFE EXPECTANCY

The number of cycles a clutch or brake will produce before it ceases to function is largely dependent on the following factors: (1) duration of slip while accelerating or decelerating a given load, (2) ability of individual unit to dissipate heat generated at friction faces, (3) thickness of friction material (used to retard wear), (4) thickness of armature plate, (5) type of bearing system used in clutch, (6) environmental conditions contributing to bearing and friction face degradation (dust, lint, grit, toner, oil, etc.). Units that are required to accelerate or stop small inertial loads at low shaft speeds (under 500 rpm) will experience little slip before lock-in at time of engagement, hence minimal wear and extremely long life, commonly in the tens of millions of cycles (typical of copy machine applications). The bearing system is usually the life limiting factor in these applications. Units that are required to accelerate or stop loads with large inertia (such as punch press fly wheels) will experience a longer duration of slip before lock-in, resulting in faster wear and the shortened life. Friction face wear only occurs while the units are slipping differentially.

Couplings

COUPLING SELECTION GUIDE

Coupling Type	Angular Misalignment > 5°	Angular Misalignment < 5°	Lateral Misalignment > .010"	Withstand Shock Loads	Vibration Dampening	High-Speeds	High Torque	High Ambient Temperature	Clean Room Environment	Stepper Motors	Reversing Drives	Maintenance Required	Vacuum Environment (No Lube)	Compressibility	Electrically Insulated
Bellows	X	X						X	X	X	X	X	X	X	
Zero Adjustable	X	X						X	X	X	X	X	X	X	
Flexible		X	X	X	X	X			X						X
Oldham		X	X				X				X	X			
Wafer Spring	X	X	X	X	X	X	X	X	X	X	X	X	X		
Universal Lateral	X	X	X		X	X			X	X	X				X
Multi-Jaw			X				X	X	X		X		X		
Universal Joint	X	X					X	X		X	X	X			
Molded Universal Joint	X	X			X	X			X	X	X				X
Sleeve Coupling				X			X	X	X		X		X		
Flexible Zero Coupling		X	X		X	X	X	X	X	X	X		X	X	
Flexible K	X	X	X	X	X	X	X	X							X
Spider Coupling	X	X	X	X	X	X				X	X				X

Bellows Couplings

The ideal solution where shafts are angularly and laterally misaligned. They feature a stainless steel hub pinned to a stainless steel bellows.

Zero Adjustable Couplings

Get the same characteristics as on the bellows type coupling, except these couplings have an adjustable hub for zeroing synchros and other similar devices.

Flexible Couplings

These will isolate vibration, absorb shock loads and electrically insulate. They feature a molded neoprene body connected to stainless steel hubs.

Miniature Oldham Couplings

A choice of center block of oil impregnated bronze or nylon (eliminates metal-to-metal contact from taking place) between the hubs. Use these couplings in high-torque applications.

Wafer Spring Couplings

The choice for your highest torque applications and where there is up to 8° of angular and .03 inches of lateral misalignment.

Universal Lateral Couplings

Not only will these couplings provide electrical insulation, but they can handle up to 10° angular and .05 inches of lateral misalignment.

Multi-Jaw Couplings

Interlocking teeth permit precision coupling/decoupling with limited transmission error between two stainless steel hubs.

Universal Joint Couplings

Working angles up to 30° are no problem when you use these coupling. Standard in either Stainless Steel or Delrin.

Precision Sleeve Couplings

Use them when coupling shafts of similar or dissimilar diameters. This allows you to couple inch to inch, millimeter to millimeter, and inch to millimeter shafts.

Flexible Zero Backlash Couplings

Work well in high accuracy systems. Stainless steel or aluminum one-piece construction with high torsional stiffness, constant velocity, and very low wind up.

Flexible K Couplings

An excellent choice for use in abrasive dust environments and where maximum flexibility is required. The hubs are zinc plated; the bodies are polyurethane.

Spider Couplings

These provide high torque transmission without backlash or vibration due to the use of a chemically resistant and electrical isolating elastomer insert.

Shaft Extensions

Used to add an additional inch of shaft length or facilitate a change from special to standard shaft diameter. — See Section 6.

FLANGE MOUNTED-POWER OFF BRAKES

24 VDC and 120 VAC 3/16", 1/4", 5/16", and 3/8" Bores

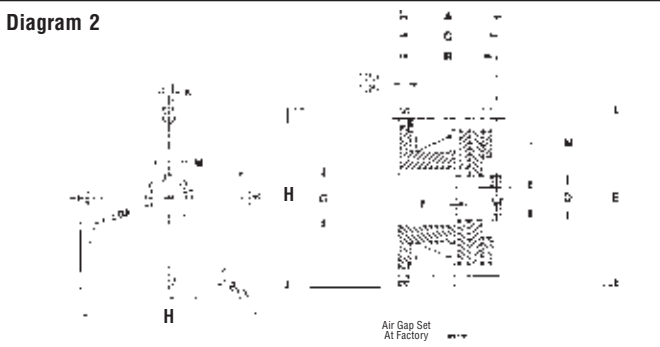
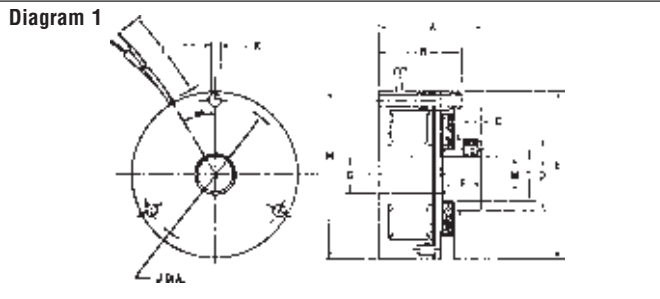

PIC Series	A	B Max.	C Nom.	D Max.	E Max.	F Min.	G Ref.	H Max.	I ±.500	J Nom.	K Min.	L Nom.	Diagram
RY5	.890	.710	.072	.510	1.485	.320	.280	1.375	12.0	1.180	.113	3/8	1
RY6	1.060	.870	.115	.755	1.910	.380	.410	1.752	12.0	1.545	.113	9/16	2
RY7	1.400	1.200	1.255	.955	2.465	.450	.781	2.436	12.0	2.125	.170	5/8	2
RY8	1.400	1.200	1.255	.722	2.465	.605	.781	2.436	12.0	2.125	.170	5/8	2

PIC Series	24 VDC		120 VAC		Key Way	M Nom.	Voltage	Part No.
	Amps	Ohms	Amps	Ohms				
RY5	170	138	.041	N.A.	1:32 x 1:16	3/16	24 VDC	RY5-302
RY6	190	132	.050	N.A.	1:32 x 1:16	3/16	120 VAC	RY5-702
RY7	247	97.3	.045	N.A.	3/64 x 3/32	1/4	24 VDC	RY5-303
RY8	359	65.1	.077	N.A.	3/64 x 3/32	1/4	120 VAC	RY5-703
					1:32 x 1:16	1/4	24 VDC	RY6-303
					1:32 x 1:16	1/4	120 VAC	RY6-703
					3/8	5/16	24 VDC	RY6-304
					3/8	5/16	120 VAC	RY6-704
					3/8	3/8	24 VDC	RY7-305
					3/8	3/8	120 VAC	RY7-705
					3/8	5/16	24 VDC	RY8-304
					3/8	5/16	120 VAC	RY8-704
					3/8	3/8	24 VDC	RY8-305
					3/8	3/8	120 VAC	RY8-705

Series	Typical Out-of-Box Torques lb.-in.	Rated Static Torques lb.-in.	Typical Torques After Burnishing lb.-in.
RY5	1	3	1.5
RY6	3	7	3
RY7	7	15	4
RY8	15	30	18

FLANGE MOUNTED-POWER ON BRAKES

24 VDC and 90 Volts DC 3/16", 1/4", 5/16", and 3/8" Bores

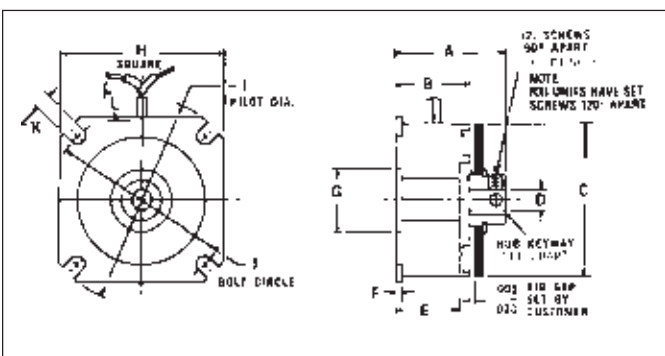

PIC Series	A	B Nom.	C Max.	E Nom.	F Max.	G ±.001	H Max.	I ±.001	J Nom.	K Min.	L ±.500
RX1	.885	.634	.905	.572	.034	NA	.980	1.1995	1.030	.094	12.0
RX2	.974	.650	1.160	.583	.052	NA	1.230	1.498	1.312	.123	12.0
RX3	1.309	.867	1.500	.805	.063	NA	1.567	1.999	1.750	.156	12.0
RX4	1.269	.848	1.780	.745	.064	NA	1.943	2.436	2.125	.186	12.0

PIC Series	Static Torque lb.-in.	Mechanical		Wgt. Oz.	D Nom.	Voltage	Part No.
		Inertia lb.-in. ²	Arm & Hub				
RX1	2.5	.011	7	3/16	90 VDC	RX1-1B2	
RX2	6	.0074	3.2	3/16	24 VDC	RX1-302	
RX3	10	.026	3.8	1/4	90 VDC	RX1-103	
RX4	15	.037	11	1/4	24 VDC	RX1-303	
				1/4	90 VDC	RX2-103	
				1/4	24 VDC	RX2-303	
				5/16	30 VDC	RX2-104	
				5/16	24 VDC	RX2-304	
				5/16	30 VDC	RX3-104	
				5/16	24 VDC	RX3-304	
				3/8	90 VDC	RX3-105	
				3/8	24 VDC	RX3-305	
				3/8	90 VDC	RX4-104	
				3/8	24 VDC	RX4-304	
				3/8	90 VDC	RX4-105	
				3/8	24 VDC	RX4-305	

PIC Series	Electrical			
	90 VDC		24 VDC	
	Amps	Ohms	Amps	Ohms
RX1	0.46	1977	.117	205
RX2	0.47	1930	.198	121
RX3	0.42	2150	.183	132
RX4	0.66	1369	.287	83

Series	Typical Out-of-Box Torques lb.-in.	Rated Static Torques lb.-in.	Typical Torques After Burnishing lb.-in.
RX1	2	2.5	3
RX2	5	6	8
RX3	8	10	15
RX4	12	15	20

To Order Alternate Bores and Voltages, Consult Factory

SHAFT MOUNTED-CLUTCHES

24 and 90 Volts DC $3/16"$, $1/4"$, $5/16"$, and $3/8"$ Bores

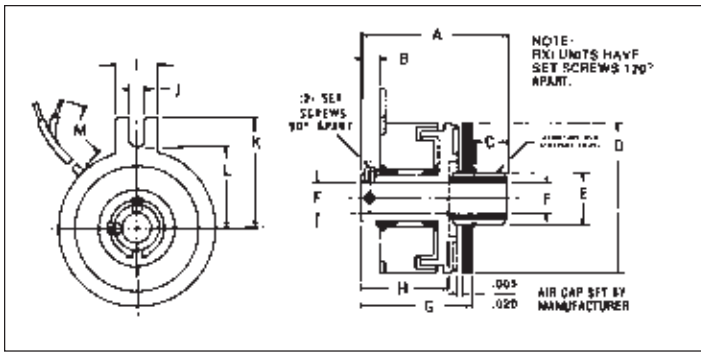

Mechanical

PIC Series	Static Torque Lb-in	Inertia Lb-in ²		Wgt. Oz.
		Rotor	Arm & Hub	
RW1	2.5	.002	.0025	2.0
RW2	6	.0058	.0029	3.2
RW3	10	.060	.0031	3.8
RW4	16	.061	.036	1?

Electrical

PIC Series	90 VDC		24 VDC	
	Amps	Ohms	Amps	Ohms
RW1	0.46	1977	1.17	206
RW2	0.47	1930	1.08	121
RW3	0.42	2150	1.83	137
RW4	0.66	1369	2.89	83

F Nom.	Voltage	Part No.
3/16	90 VDC	RW1-122
3/16	24 VDC	RW1-322
1/4	90 VDC	RW1-133
1/4	24 VDC	RW1-333
5/16	90 VDC	RW2-133
5/16	24 VDC	RW2-333
5/16	90 VDC	RW2-144
5/16	24 VDC	RW2-344
3/8	90 VDC	RW3-144
3/8	24 VDC	RW3-344
3/8	90 VDC	RW3-155
3/8	24 VDC	RW3-355
3/8	90 VDC	RW4-144
3/8	24 VDC	RW4-344
3/8	90 VDC	RW4-155
3/8	24 VDC	RW4-355

To Order Alternate Bores and Voltages, Consult Factory

Dimensions

PIC Series	A	B Nom.	C	D Max.	E ±.002	G Nom.	H Nom.	I Max.	J Min.	K Nom.	L Max.	M Min.	N Nom.	O Nom.	P ±.500
RW1	1.370	.191	.410	.903	.506	.674	.763	.305	.091	.625	.445	12.00			
RW2	1.205	.147	.336	1.150	.506	.935	.777	.380	.122	.875	.585	12.00			
RW3	1.700	.273	.303	1.520	.630	1.255	1.075	.508	.180	1.120	.750	12.00			
RW4	1.623	.270	.355	1.750	.630	1.314	1.060	.565	.184	1.325	.875	12.00			

Series	Torque Build-up Time — Milliseconds				Torque Decay Time MS
	Rated Static Torque (lb.-in.)	65% of Rated Torque	80% of Rated Torque	100% of Rated Torque	
RW1	2.5	3.3	4.8	7.5	6.6
RW2	6	5.5	2.2	10.5	11
RW3	10	6	9	12	17
RW4	15	8	10	14	14

SLIP CLUTCHES — CONTINUOUS SLIP OPERATION

$1/8"$, $3/16"$, and $1/4"$ Bores and 3, 4, 6 mm Bores

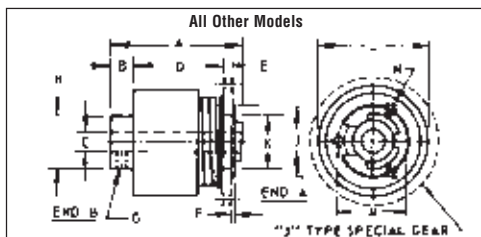
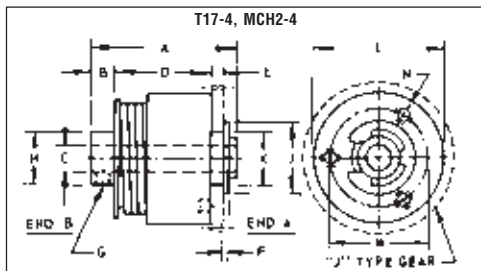

Pre-set Slip Torque Bi-directional (Oz. In.)	A	B	C +0.0005 -0.0000	D	E	F	G	H	J +0.0000 -0.0008	K	L	M	N	Part No.
9 ± 1	1.05	.18	.1246	.72	.080	.03	#2-56	.38	.45	3740	.63	.500	#0.80 x .08 deep	T17-1
20 ± 2	1.24	.21	.1873	.85	.095	.04	#4-40	.50	.58	4990	1.00	.650	#1.72 x .10 deep	T17-2
20 ± 2	1.24	.21	.2498	.85	.095	.04	#4-40	.50	.68	4990	1.00	.650	#1.72 x .10 deep	T17-3
48 ± 5	1.39	.23	.2498	.94	.130	.04	#6-32	.50	.68	4990	1.25	.925	#2.56 x .11 deep	T17-4
80 ± 8	1.39	.23	.2498	.94	.130	.04	#6-32	.63	.68	4990	1.50	.925	#2.56 x .11 deep	T17-5
120 ± 12	1.67	.25	.2498	1.20	.130	.04	#6-32	.63	.59	4990	1.87	.780	#4.40 x .15 deep	T17-6

Dimensions below are in millimeters.

Pre-set Slip Torque Bi-directional (N-m)	A	B	C +0.015 -0.008	D	E	F	G	H	J +0.00 -0.02	K	L	M	N	Part No.
0.064 ± 0.007	26.67	4.57	2.995	18.29	2.03	0.76	M2x4	9.65	11.43	9.500	16.00	12.70	#0.80 x .08 deep	MCH2-1
0.141 ± 0.014	31.50	5.33	3.995	21.59	2.41	1.02	M3x4	12.70	17.27	12.675	25.40	16.51	#1.72 x .10 deep	MCH2-2
0.141 ± 0.014	31.50	5.33	5.995	21.59	2.41	1.02	M3x5	12.70	17.27	12.675	25.40	16.51	#1.72 x .10 deep	MCH2-3
0.339 ± 0.035	35.31	5.84	5.995	23.88	3.30	1.02	M3x5	12.70	17.27	12.675	31.75	23.50	#2.56 x .11 deep	MCH2-4
0.565 ± 0.057	35.31	5.84	5.995	23.88	3.30	1.02	M3x5	16.00	17.27	12.675	38.10	23.50	#2.56 x .11 deep	MCH2-5
0.847 ± 0.085	42.42	6.35	5.995	30.48	3.30	1.02	M3x5	16.00	14.99	12.675	47.50	19.81	#4.40 x .15 deep	MCH2-6

FEATURES

- Mounting provision for modified "J" Gears, Pulleys and Sprockets
- Stainless Steel with Bronze Bearings
- Same or Different Torques Available for Two Directions of Rotation - See Special Ordering Information
- Precise and stable limit Torque
- Same Torque at breakway as at high slip velocity
- Torque Range: 2 to 120 Oz. In.

Higher Torques - To 240 Oz. In.
Larger Bores - To 1/2"
Available on Request

*SPECIALS

Torque Range	
Max. Oz. In.	Min. Oz. In.
9 ± 1	2 ± .5
20 ± 2	5 ± .
20 ± 2	5 ± .
48 ± 5	10 ± 1.5
80 ± 8	20 ± 3
120 ± 12	30 ± 4

TO ORDER SPECIAL TORQUE SETTINGS:

Refer to Torque Range Min — Max. values to obtain the practical Torque Ranges available for each basic clutch.

SPECIFY Basic Part Number Required Torque for End A, CW Rotation — Required Torque for End A, CCW Rotation.

EXAMPLE: Special Slip Clutch

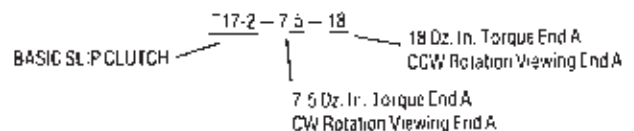

SLIP CLUTCHES — CONTINUOUS SLIP OPERATION

Adjustable Torque

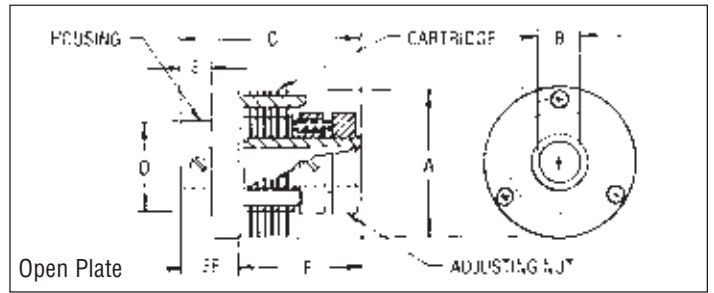

Material:

- Housing — Steel; Zinc Plated
- Clutch Plates — Brass
- Friction Plates — Proprietary (Non Asbestos)

$$\text{Maximum RPM} = \frac{\text{WATTS (From Table Below)}}{\text{Torque (oz.-in.)} \times .0007}$$

Dimensions And Capacity Rating										
A	Bore B +0.002 -0.000	C	D ±.005	E	EE	F	Capacity		Friction Surfaces	Part No*
							oz.-in.	Watts		
1.00	.250	1.06	.76	.25	Cartridge Enclosed		.3 to 32	1.0	2	T25-164-2S T25-164-2H
1.00	.250	1.31	.76	.25			4.8 to 160	5.8	8	T25-164-8S T25-164-8H
1.25	.250	1.50	.76	.25	.50	1.00	1.6 to 160	6.0	8	T25-204-S T25-204-H
1.50	.375	2.50	1.01	.37	.75	1.75	8 to 400	14.5	12	T25-246-S T25-246-H
2.00	.500	2.87	1.38	.50	1.00	1.88	12.8 to 800	29.0	12	T25-328-S T25-328-H

Features:

- A multi plate slip clutch
- Adjustable torque
- Preset torque available on special orders (Torque setting ± 10%)
- Can be used as a slip coupling
- Backlash of 6° is standard
- Constant tension
- Overload protection
- Controlled slip
- Clutches exhibit same torque in either direction
- Shaft to shaft clutch/coupling or thru shaft to pulley, gear, etc.
- Bronze bearing in housing for thru-shaft to pulley models
- Low stick-slip ratio

Capacity at continuous duty, 50 RPM, 25 million cycles (Rev)

- *Note:
- For shaft to shaft coupling, set screws in both housing and cartridge — use Part No. ending with "S"
 - For thru shaft to housing (pulley, gear, etc.), bronze bearing in housing, set screw in cartridge — use Part No. ending with "H"
 - Metric bores can be accomplished by use of bore reducers (5,6,8 & 10 mm finished bores) found in the catalog
 - Consult factory for other bore sizes

SLIP COUPLINGS — CONTINUOUS SLIP OPERATION

1/8", 3/16", and 1/4" Bores and 3, 4, 6 mm Bores

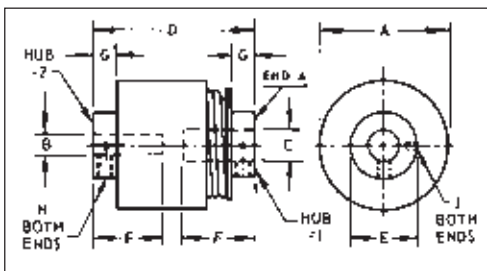

FEATURES

- Misalignment Allowance between shafts - 0.006"
- Stainless Steel
- Same or Different Torques Available for Two Directions of Rotation - See Special Ordering Information
- Torque Range: 1 to 120 Oz. In.
- Precise and stable limit Torque
- Same Torque at breakaway as at high slip velocity

Special Bores - 1/8" to 1/2"
Higher Torques - To 240 Oz. In.
Larger Bores - To 1 1/2"
Available on Request

*SPECIALS Torque Range	
Max. Oz. In.	Min. Oz. In.
12 ± 1.2	3 ± .5
20 ± 2	5 ± 1
48 ± 5	10 ± 1.5

Inch Bores Toler. + .0005 - .0000	Pre-Set Slip Torque Bi- directional	A	B	C	D	E Max	F	G	H	Part No.					
											Dimensions below are in millimeters.				
1/8"	12 ± 1.2 Oz. In.	.75	1875	1875	.11	.63	.50	.13	#4-20	T18-4					
			1875	2500						T18-5					
			2500	2500						T18-6					
3/16"	20 ± 2 Oz. In.	1.00	1875	1875	.26	.63	.55	.13	#4-40	T18-7					
			1875	2500						T18-8					
			2500	2500						T18-9					
1/4"	48 ± 5 Oz. In.	1.25	2500	2500	.43	1.01	.62	.25	#6-32	T18-10					
			2500	3750						T18-11					
			3750	3750						T18-12					
Metric Bores Toler. + .013 - .008	0.335 ± 0.005 N-m	12.70	3	3	22.60	12.5	10.92	4.32	M2X 4	MCU17-1					
			3	4						MCU17-2					
			4	4						MCU17-3					
			4	4						MCU17-4					
			4	6						28.9	16	12.70	4.83	M2X 4	MCU17-5
			6	6						MCU17-6					
0.41 ± 0.014 N-m	25.00	15.80	4	4	32.00	16	13.97	4.83	M2X 4	MCU17-7					
			4	6						MCU17-8					
			6	6						MCU17-9					
			6	6						MCU17-9					

TO ORDER SPECIAL TORQUE SETTINGS

Refer to Torque Range Min. — Max. values to obtain the practical torque ranges available for each basic coupling.

EXAMPLE: Special Slip Coupling: T18-10 — 12 — 44

44 Oz. In. Torque Hub = 1, CCW Rotation Viewing End A

12 Oz. In. Torque Hub = 1, CW Rotation Viewing End A

SPECIFY Basic Part Number Required Torque for Hub #1 Rotating CW — Required Torque for Hub #1, Rotating CCW.

SLIP CLUTCH ASSEMBLY — ADJUSTABLE-MOMENTARY OVERLOAD*

Pin Hub = 1/8", 3/16", and 1/4" Bores and 3, 4, 6 mm Bores

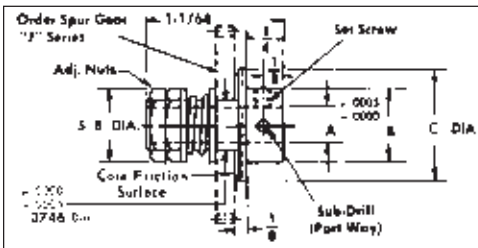

Part No.	Friction Surface
MCH3-2 -4, -6	Pads
MCH3-1 -3, -5	Ring

ADJUSTABLE TO
10 OZ IN TORQUE
FOR 10 TO 50
OZ IN TORQUE
ADD 50 TO CAT. NO.

Part No.	Friction Surface
R3-3 11, 12	Pads
	Ring

ADJUSTABLE TO
10 OZ IN TORQUE
FOR 10 TO 50
OZ IN TORQUE
ADD 50 TO CAT. NO.

Inch Bores Toler. +.0005 -0.0008	Shaft Size	A	B	C	Set Screw	Part No.
	1/8	.1248	.312	5/8	#2-56	R3-10
	3/16	.1873	.375	5/8	#2-40	R3-11
	1/4	.2498	.500	5/8	#6-32	R3-12 R3-3

Dimensions below are in millimeters.

Metric Bores Toler. +.013 -0.000	Shaft Size	A	B	C	Set Screw	Part No.
	3	2.995	7.92	15.88 25.40	M2X 4	MCH3-1 MCH3-2
	4	3.995	9.52	15.88 25.40	M2X 4	MCH3-3 MCH3-4
	6	5.995	12.70	15.88 25.40	M3X 5	MCH3-5 MCH3-6

*Not to be used for continuous slippage. For continuous Duty Slip Clutch See T17 MCH2 Series

Material: Stainless Steel

Clamp Type = 1/8", 3/16", and 1/4" Bores and 3, 4, 6 mm Bores

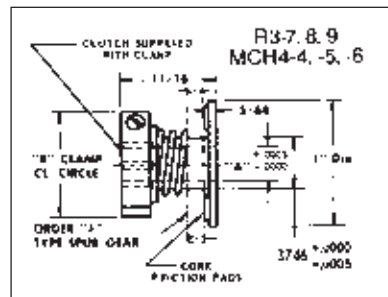
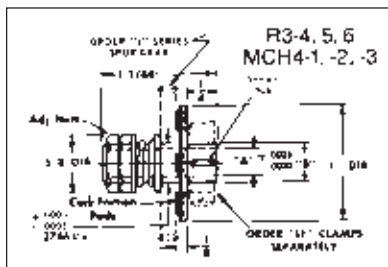

Inch Bores Toler. +.0005 -0.0008	Shaft Size	A	B	Clamp	Part No.
	1/8	.1248	.186	L1-4	R3-4
	3/16	.1873	.250	L1-5	R3-5
	1/4	.2498	.312	L1-6	R3-6
	1/8	.1248	.186	L1-4	R3-7
	3/16	.1873	1.137	L1-5	R3-8
	1/4	.2498	1.148	L1-6	R3-9

Dimensions below are in millimeters.

Metric Bores Toler. +.013 -0.000	Shaft Size	A	B	Clamp	Part No.
	3	2.995	4.78	L1-4	MCH4-1
	4	3.995	6.35	L1-5	MCH4-2
	6	5.995	7.92	L1-6	MCH4-3
	3	2.995	22.23	L1-4	MCH4-4
	4	3.995	26.18	L1-5	MCH4-5
	6	5.995	28.58	L1-6	MCH4-6

Material: Stainless Steel

*Not to be used for continuous slippage. For continuous Duty Slip Clutch See T17 MCH2 Series

IN-LINE COUPLING & SLIP CLUTCHES — ADJUSTABLE-INTERMITTENT DUTY

1/8", 3/16", and 1/4" Bores and 3, 4, 6 mm Bores

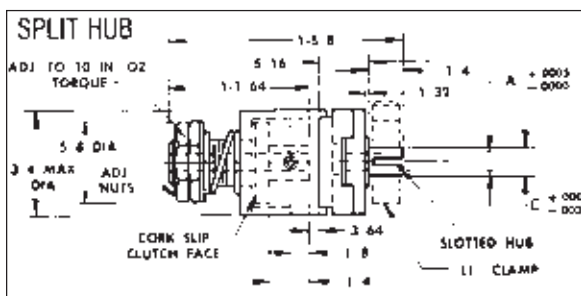
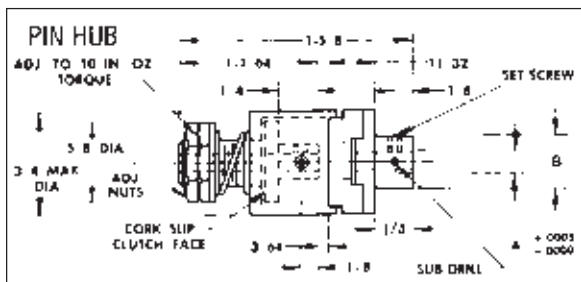

Inch Bores Toler. +.0005 -0.0008	Shaft Size	A	B	C	Set Screw	Clamp No. (Ref.)	Pin Hub Part No.	Split Hub Part No.
	1/8 to 3/16	.1248	37	.250	#4-40	L1-5	T14-7	T14-10
		.1873						
	3/16 to 3/16	.1873	37	.250	#4-40	L1-5	T14-2	T14-5
		.1873						
	3/16 to 1/4	.2498	50	.312	#6-32	L1-6	T14-9	T14-12
		.2498						

Dimensions below are in millimeters.

Metric Bores Toler. +.013 -0.000	Shaft Size	A	B	C	Set Screw	Clamp No. (Ref.)	Pin Hub Part No.	Split Hub Part No.
	3 to 3	2.995	7.92	4.78	M2X 4	L1-4	MCU18-1	MCU19-1
		3.995						
	3 to 4	2.995	9.52	6.35	M2X 4	L1-5	MCU18-2	MCU19-2
		3.995						
	3 to 6	2.995	12.70	7.92	M2X 4	L1-6	MCU18-3	MCU19-3
		5.995						
	4 to 4	3.995	9.52	6.35	M2X 4	L1-5	MCU18-4	MCU19-4
		3.995						
	4 to 6	3.995	12.70	7.92	M2X 4	L1-6	MCU18-5	MCU19-5
		5.995						
	6 to 6	5.995	12.70	7.92	M3X 5	L1-6	MCU18-6	MCU19-6

*Adjustable End's first shaft size shown.
For 10 to 50 n.m. Torque Adjustment. Add - 50 to Part Number. Available with 0.07 to 0.35 N-m on Request.

Material: 303 Stainless Steel

ROLLER CLUTCHES

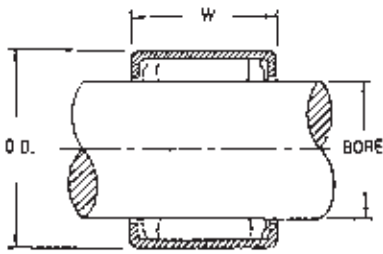

Lock Function
 Shaft Drives Gear
 Clockwise (top arrows)
 or
 Gear Can Drive Shaft
 Counter-Clockwise
 (bottom arrows)



Overrun Function
 Shaft Overruns in Gear
 Counter-Clockwise
 (top arrows)
 or
 Gear Overruns on
 Shaft: Clockwise
 (bottom arrow)



Material:
 Roller Cup - Case Hardened Steel
 Needle Bearing - 52100 Hardened
 Chrome Steel
Cage: Acetal with Integral leaf springs

- Ideal for indexing, backstopping or overrunning operations
- Free rolling one way, drives in opposite direction
- Light weight, low profile
- High indexing, frequency
- Temperature max 200°F
- Maximum Backlash
- Shaft should be RC58 min. with 16μ" finish or better

Bore	O.D.	W +.000 -.010	Torque Rating in LB	Overrun Limiting Speed RPM	Mounting Dim.		Part No.
					Shaft Dia. +.0000 -.0005	Hsg. Bore Dia. +.001 -.000	
1/8	9/32	250	2.85	50,000	.1250	.2812	EC-02-04
1/4	7/16	500	17.2	21,000	.2500	.4370	EC-04-07
3/8	5/8	500	45.4	14,000	3/50	.6245	EC-06-10
1/2	3/4	500	75.5	11,000	.5000	.7495	EC-08-12
5/8	7/8	625	143	8,500	.6250	.8745	EC-10-14
3/4	1	625	196	7,000	.7500	.9995	EC-12-16

BACKLASH FREE ELASTOMER JAW "SPIDER" COUPLING

1/8" to 1/2" Diameter Bores and 4mm to 12mm Bores

Features:

- For electrical isolation and chemical resistance
- Coupling with Integral radial clamp using socket head cap screws
- High torsional stiffness:
 - Static 4.5 Lbf-Ft/deg (700Nm/rad)
 - Dynamic 9 Lbf-Ft/deg (350Nm/rad)
- Misalignment Tolerances:
 - Angular 0.8°
 - Lateral .002" (.06 mm)
 - Axial ± .039" (1 mm)
- Temp. Range (due to elastomer)
 22° to 248°F (-30° to 120°C)

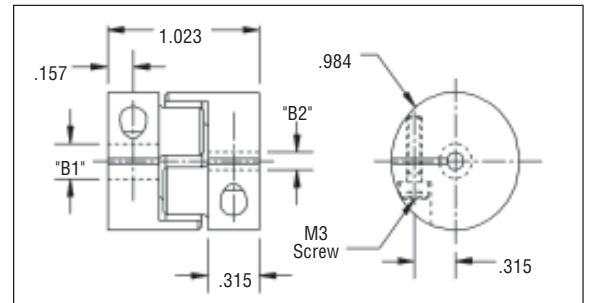
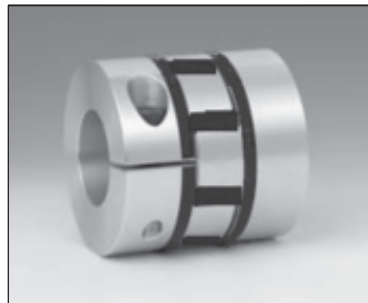

Specifications: Inch / (Metric)

- Rated Torque 106 Lbf-in / (12Nm)
- Over all length 1.02" / (26mm)
- C Fit Length .315" / (8mm)
- Clamping Screw M3
- Torque to tighten screw 17.7 Lbf-in / (2Nm)
- Aprox. Weight .07 oz / (.02 kg)
- Bore Tolerance +.001" / (H7)
 -.000

Material:

- Hubs: High Strength Aluminum
- Elastomer Insert: Precision molded, wear resistant and thermally stable polymer 64 Shore D

Inch bores

B ₁ / B ₂ Bore	Part Number
.188	T13E-18
.250	T13E-25
.250/.188	T13E-2518
.3125	T13E-31
.3125/.188	T13E-3118
.3125/.250	T13E-3125
.375	T13E-37
.375/.188	T13E-3718

Inch bores

B ₁ / B ₂ Bore	Part Number
.375/.250	T13E-3725
.375/.3125	T13E-3731
.500	T13E-50
.500/.188	T13E-5018
.500/.250	T13E-5025
.500/.3125	T13E-5031
.500/.375	T13E-5037

Metric Bores

B ₁ / B ₂ Bore	Part Number
4	T13E-4M
5	T13E-5M
5/4	T13E-5M4M
6	T13E-6M
6/5	T13E-6M5M
6/4	T13E-6M4M
8	T13E-8M
8/4	T13E-8M4M
8/5	T13E-8M5M
8/6	T13E-8M6M
12/10	T13E-12M10M

Metric to Inch

B ₁ / B ₂ Bore	Part Number
4M/.188	T13E-4M18
5M/.188	T13E-5M18
4M/.250	T13E-4M25
5M/.375	T13E-5M37
6M/.375	T13E-6M37
4M/.500	T13E-4M50
6M/.500	T13E-6M50
10M/.500	T13E-10M50
12M/.500	T13E-12M50

Other bore sizes and combinations available between inch (.188 to .500) and metric (4mm to 12mm) ranges. Please consult factory.

WAFER SPRING COUPLINGS

.12 To .50 Inch Bores and 3 To 12 mm Bores

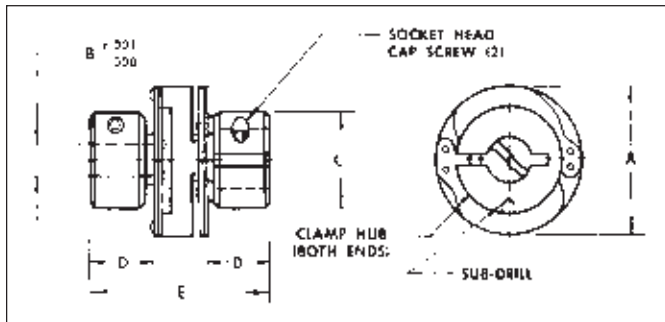

Material: Hubs and center members – Anodized Aluminum
 Leaves – 17-7PH S.S.
 Fasteners – Stainless Steel

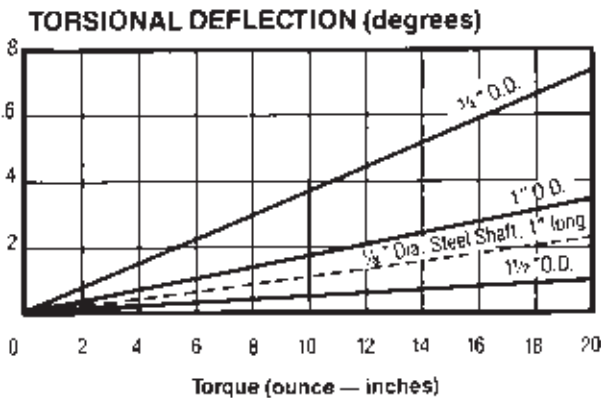
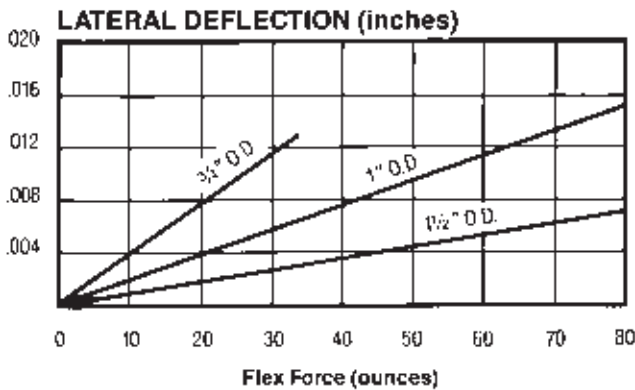

Inch Bores Toler. +.001 -.000	B	A	C	D	E	Set Screw	Part No.
	1200/ 1250	3/4	9/16	19/64	7/8	#2-56	T15-1
1200/ 1875	T15-3						
1200/ 2500	T15-4						
1250	T15-5						
1250/ 1875	T15-7						
1875	T15-12						
1875/ 2500	1	.75	.44	1.25	#4-40	T15-13	
2500						T15-14	
1875						T15-22	
1875/ 2500						T15-23	
2500						T15-24	
2500/ 3125						T15-25	
3125	1 1/2	1	21/32	1-13/16	#6-32	T15-26	
2500/ 3125						T15-15	
2500/ 3750						T15-16	
3125						T15-17	
3125/ 3750						T15-18	
3750						T15-19	
3750/ 5000	T15-20						
5000	T15-21						

Dimensions below are in millimeters.

Metric Bores Toler. +.025 -.000	B		C	D	E	Set Screw	Part No.				
	3 to 3	19.05	14.22	7.62	22.35	M2X.4	MCU15-1				
3 to 4	MCU15-2										
3 to 6	MCU15-3										
4 to 4	MCU15-4										
4 to 6	MCU15-5										
6 to 6	MCU15-6										
6 to 6	25.40	19.05	11.18	31.75	M3X.5	MCU15-7					
6 to 8						MCU15-8					
8 to 8						MCU15-9					
6 to 8						38.10	25.40	16.76	45.97	M4X.7	MCU15-10
8 to 8											MCU15-11
8 to 10											MCU15-12
10 to 10	MCU15-13										
10 to 12	MCU15-14										
12 to 12	MCU15-15										

Model No.	O.D. (A)	Torque (Oz-in) Max.	Angular Deflection		Lateral Deflection		Max. Axial Deflection (inches)
			Flex Force* (oz.)	Degrees Max.	Flex Force* (oz.)	Inches Max.	
T15-1 thru 14 MCU15-1 thru MCU15-6	3/2"	165	5.2	8	48	.018	.023
T15-22 thru 26 MCU15-7 thru MCU15-9	1"	225	13.0	8	108	.020	.030
T15-15 thru 21 MCU15-10 thru MCU15-15	1 1/2"	440	26.0	8	344	.030	.045

*The force required to flex coupling to maximum deflection, applied at point one diameter from coupling center. This force is constant through 360° rotation.

Maximum speed 5000 RPM

BELLOWS COUPLINGS

.12 to 3/8" Bore and 3 mm to 10 mm Bores

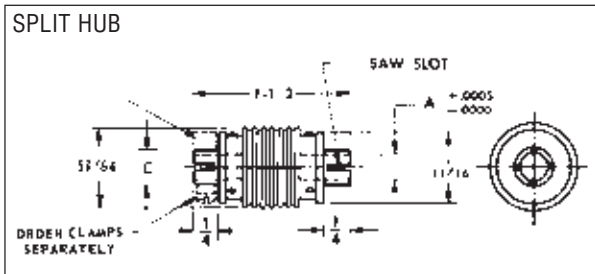
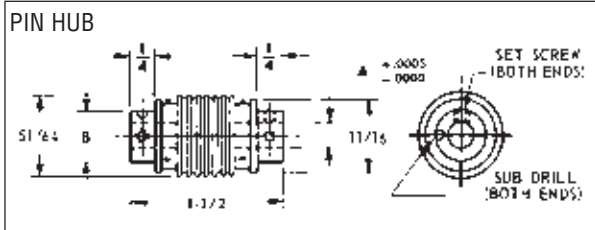

Material: Stainless Steel

Torque 75 oz. in.
 Shaft to Shaft Misalignment 0.010"
 Angular Misalignment 5°
 Backlash Negligible

	Shaft Size	A	B	C	Set Screw	Clamp No. (Ref.)	Pin Hub Part No.	Split Hub Part No.
Inch Bores Toler. +.0005 -.0000	.12 to 1/8	.1200 .1248	.312	.188	#2-56	L1-4	T1-15	T1-18
	.12 to 1/4	.1200 .2498	.312 .500	.188 .312	#2-56 #6-32	L1-4 L1-6	T1-17	T1-20
	1/8 to 1/8	.1248	.312	.188	#2-56	L1-4	T1-1	T1-8
	1/8 to 3/16	.1248 .1873	.312 .375	.188 .250	#2-56 #4-40	L1-4 L1-5	T1-4	T1-11
	1/8 to 1/4	.1248 .2498	.312 .500	.188 .312	#2-56 #6-32	L1-4 L1-6	T1-5	T1-12
	3/16 to 3/16	.1873	.375	.250	#4-40	L1-5	T1-2	T1-9
	3/16 to 1/4	.1873 .2498	.375 .500	.250 .312	#4-40 #6-32	L1-5 L1-6	T1-6	T1-13
	1/4 to 1/4	.2498	.500	.312	#6-32	L1-6	T1-3	T1-10
	5/16 to 5/16	.3123	.500	.375	#6-32	L1-20	T1-21	T1-23
	3/8 to 3/8	.3748	.625	.438	#8-32	L1-21	T1-22	T1-24

Dimensions below are in millimeters.

	Shaft Size	A	B	C	Set Screw	Clamp No. (Ref.)	Pin Hub Part No.	Split Hub Part No.
Metric Bores Toler. +.013 -.000	3 to 3	2.995	7.92	4.78	M2X.4	L1-4	MCU1-1	MCU2-1
	3 to 4	2.995	7.92	4.78	M2X.4	L1-4	MCU1-2	MCU2-2
		3.995	9.52	6.35		L1-5		
	3 to 6	2.995	7.92	4.78	M2X.4	L1-4	MCU1-3	MCU2-3
		5.995	12.70	7.92		L1-6		
	4 to 4	3.995	9.52	6.35	M2X.4	L1-5	MCU1-4	MCU2-4
		3.995	9.52	6.35		L1-6		
	4 to 6	3.995	9.52	6.35	M2X.4	L1-5	MCU1-5	MCU2-5
		5.995	12.70	7.92		L1-6		
	6 to 6	5.995	12.70	7.92	M3X.5	L1-6	MCU1-6	MCU2-6
8 to 8	7.995	12.70	9.60	M3X.5	L1-20	MCU1-7	MCU2-7	
10 to 10	9.995	16.40	11.60	M4X.7	L1-21	MCU1-8	MCU2-8	

ZERO ADJUSTABLE COUPLINGS

1/8" to 3/8" Bore and 3 mm to 10 mm Bores

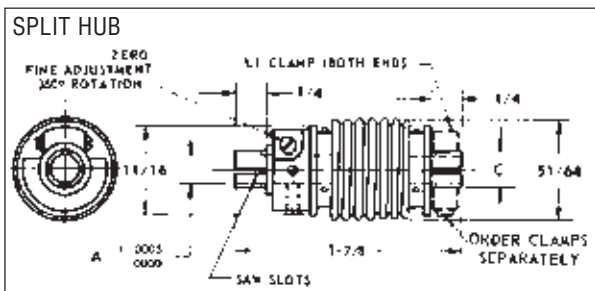
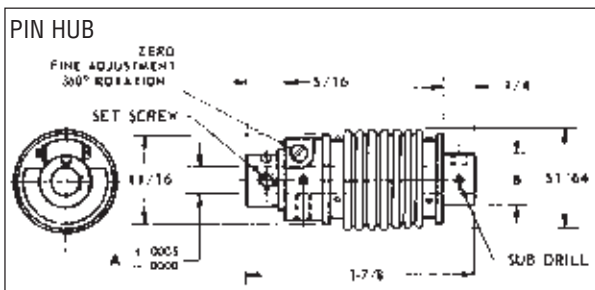

Material: Stainless Steel

	Shaft Size	A	B	C	Set Screw	Clamp No. (Ref.)	Pin Hub Part No.	Split Hub Part No.
Inch Bores Toler. +.0005 -.0000	1/8 to 1/8	.1248	5/16	.188	#2-56	L1-4	T9-1	T10-1
	1/8 to 3/16	.1248	5/16	.188	#2-56	L1-4	T9-7	T10-7
		.1873	3/8	.250	#4-40	L1-5		
	1/8 to 1/4	.1248	5/16	.188	#2-56	L1-4	T9-8	T10-8
		.2498	1/2	.312	#6-32	L1-6		
	3/16 to 3/16	.1873	3/8	.250	#4-40	L1-5	T9-2	T10-2
		.1873	3/8	.250	#4-40	L1-5		
	3/16 to 1/4	.1873	3/8	.250	#4-40	L1-5	T9-9	T10-9
		.2498	1/2	.312	#6-32	L1-6		
	1/4 to 1/4	.2498	1/2	.312	#6-32	L1-6	T9-3	T10-3
.2498		1/2	.312	#6-32	L1-6			
5/16 to 5/16	.3123	.500	.375	#6-32	L1-20	T9-11	T10-11	
	.3123	.500	.375	#6-32	L1-20			
3/8 to 3/8	.3748	.625	.438	#8-32	L1-21	T9-12	T10-12	

Dimensions below are in millimeters.

	Shaft Size	A	B	C	Set Screw	Clamp No. (Ref.)	Pin Hub Part No.	Split Hub Part No.
Metric Bores Toler. +.013 -.000	3 to 3	2.995	7.92	4.78	M2X.4	L1-4	MCU3-1	MCU4-1
	3 to 4	2.995	7.92	4.78	M2X.4	L1-4	MCU3-2	MCU4-2
		3.995	9.52	6.35		L1-5		
	3 to 6	2.995	7.92	4.78	M2X.4	L1-4	MCU3-3	MCU4-3
		5.995	12.70	7.92		L1-6		
	4 to 4	3.995	9.52	6.35	M2X.4	L1-5	MCU3-4	MCU4-4
		3.995	9.52	6.35		L1-6		
	4 to 6	3.995	9.52	6.35	M2X.4	L1-5	MCU3-5	MCU4-5
		5.995	12.70	7.92		L1-6		
	6 to 6	5.995	12.70	7.92	M3X.5	L1-6	MCU3-6	MCU4-6
8 to 8	7.995	12.70	9.60	M3X.5	L1-20	MCU3-7	MCU4-7	
10 to 10	9.995	16.40	11.60	M4X.7	L1-21	MCU3-8	MCU4-8	

* Adjustable end is first shaft size shown.

One turn of adjusting screw rotates coupling hub 12 degrees. Hub and shaft remain fixed during adjustment.

FLEXIBLE COUPLINGS

.12 to 1/4" Bore and 3 mm to 6 mm Bores

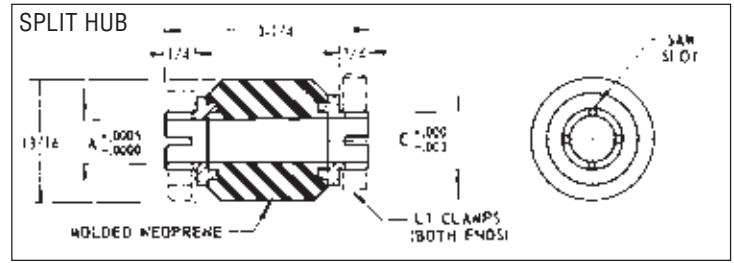
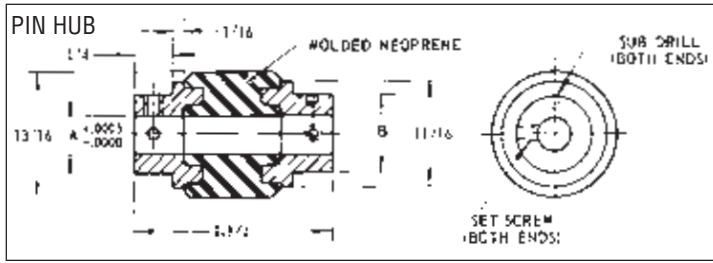

Material: 303 Stainless Steel Hubs.
Neoprene (Center Section)

FEATURES

- Allows Shaft to Shaft Misalignment
- Isolates Torsional Vibration
- Insulates Between Units

SPECIFICATIONS

MAXIMUM ANGULAR MISALIGNMENT	2°
MAXIMUM LATERAL MISALIGNMENT	.010"
MAXIMUM WORKING TORQUE	100 OZ-IN
MAXIMUM SPEED	1000 RPM

	Shaft Size	A	B	C	Set Screw	Clamp No. (Ref.)	Pin Hub Part No.	Split Hub Part No.
Inch Bores Toler. +.0005 -0.0000	.12 to 1/8	.1200 .1248	5/16	.188	#2-56	L1-4	T11-7	T12-7
	.12 to 3/16	.1200 .1873	5/16 3/8	.188 .250	#2-56 #4-40	L1-4 L1-5	T11-10	T12-10
	.12 to 1/4	.1200 .2498	5/16 1/2	.188 .312	#2-56 #6-32	L1-4 L1-6	T11-9	T12-9
	1/8 to 1/8	.1248	5/16	.188	#2-56	L1-4	T11-1	T12-1
	1/8 to 3/16	.1248 .1873	5/16 3/8	.188 .250	#2-56 #4-40	L1-4 L1-5	T11-4	T12-4
	1/8 to 1/4	.1248 .2498	5/16 1/2	.188 .312	#2-56 #6-32	L1-4 L1-6	T11-5	T12-5
	5/32 to 3/16	.1562 .1873	5/16 3/8	.250	#2-56 #4-40	L1-5	T11-8	T12-8
	3/16 to 3/16	.1873	3/8	.250	#4-40	L1-5	T11-2	T12-2
	3/16 to 1/4	.1873 .2498	3/8 1/2	.250 .312	#4-40 #6-32	L1-5 L1-6	T11-6	T12-6
	1/4 to 1/4	.2498	1/2	.312	#6-32	L1-6	T11-3	T12-3

Dimensions below are in millimeters.

	Shaft Size	A	B	C	Set Screw	Clamp No. (Ref.)	Pin Hub Part No.	Split Hub Part No.
Metric Bores Toler. +.013 -0.000	3 to 3	2.995	7.92	4.78	M2X.4	L1-4	MCU7-1	MCU8-1
	3 to 4	2.995	7.92	4.78	M2X.4	L1-4	MCU7-2	MCU8-2
		3.995	9.52	6.35		L1-5		
	3 to 6	2.995	7.92	4.78	M2X.4	L1-4	MCU7-3	MCU8-3
		5.995	12.70	7.92		L1-6		
	4 to 4	3.995	9.52	6.35	M2X.4	L1-5	MCU7-4	MCU8-4
		3.995	9.52	6.35		L1-5		
	4 to 6	5.995	12.70	7.92	M2X.4	L1-6	MCU7-5	MCU8-5
5.995		12.70	7.92	L1-6				
6 to 6	5.995	12.70	7.92	M3X.5	L1-6	MCU7-6	MCU8-6	

UNIVERSAL LATERAL COUPLINGS

1/8", 3/8", and 1/4" Bores and 3, 4, 6 mm Bores

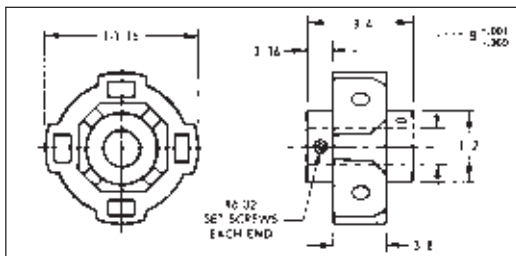

Features

- Simultaneous lateral and angular misalignment
- Corrosion resistant
- Electrically insulated
- Light weight and space saving
- No lubrication required
- Separable

Specifications

Maximum angular misalignment:	10°
Maximum lateral misalignment:	.050 inches
Maximum working torque:	15 lb. in.
Backlash:	Negligible
Weight (1/2" bore):	.5 ounces
Trunnion material:	Nickel plated metal
Annular ring material:	Delrin
Standard connection to shaft:	Socket head cup point set screw

INCH			METRIC		
Tolerance	B	Part No.	Tolerance	B	Part No.
+.001" -0.000"	.1200	T16-7	+.025 mm -0.000 mm	3	MUJ1-1
	.1200 & .1250	T16-8		4	MUJ1-4
	.1250	T16-1		3 & 4	MUJ1-2
	.1250 & .1875	T16-2		3 & 5	MUJ1-7
	.1250 & .250	T16-3		3 & 6	MUJ1-3
	.1875	T16-4		4 & 5	MUJ1-8
	.1875 & .250	T16-5		4 & 6	MUJ1-5
	.1875 & .3125	T16-9		5 & 5	MUJ1-9
	.2500	T16-6		5 & 6	MUJ1-10
	.2500 & .3125	T16-10		6	MUJ1-6
	.3125	T16-11			

INCH TO METRIC

Tolerance	B	Part No.	
Inch Bores	.1875" & 5 mm	T16C4-9	
+.001"	.1875" & 6 mm	T16C4-6	
	.2500" & 3 mm	T16C6-1	
Metric Bores	.2500" & 4 mm	T16C6-4	
	+.025 mm	.2500" & 5 mm	T16C6-9
	-0.000 mm	.2500" & 6 mm	T16C6-6

MULTI-JAW COUPLINGS — 64 PITCH

1/8", 3/16", and 1/4" Bores and 3, 4, 6 mm Bores

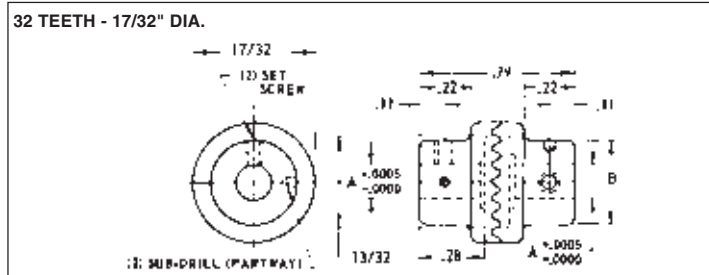
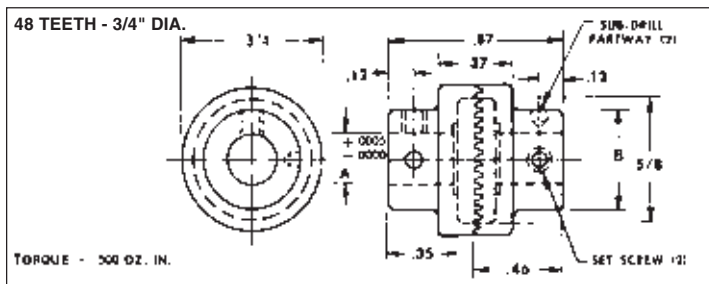

Material: 303 Stainless Steel

Inch Bores	Shaft Size	A	B	Set Screw	48 Teeth Part No.	32 Teeth Part No.
Toler. +.0005 - .0000	1/8 to 1/8	.1248	.31	#2-56	N4-1	N5-1
	1/8 to 3/16	.1248 .1873	.31 .37	#2-56 #4-40	N4-6	N5-6
	1/8 to 1/4	.1248 .2498	.31 .50	#2-56 #6-32	N4-7	N5-7
	3/16 to 3/16	.1873	.37	#4-40	N4-2	N5-2
	3/16 to 1/4	.1873 .2498	.37 .50	#4-40 #6-32	N4-8	N5-8
	1/4 to 1/4	.2498	.50	#6-32	N4-3	N5-3

Dimensions below are in millimeters.

Metric Bores	3 to 3	3 to 4	3 to 6	4 to 4	4 to 6	6 to 6	Set Screw	Clamp No. (Rel.)	Pin Hub Part No.	Split Hub Part No.
Toler. +.013 - .000	2.995	2.995	2.995	3.995	3.995	5.995	M2X.4	L1-4	MCU13-1	MCU14-1
	7.92	7.92	7.92	9.52	9.52	12.70	M2X.4	L1-4	MCU13-2	MCU14-2
	5.995	5.995	5.995	3.995	3.995	5.995	M2X.4	L1-6	MCU13-3	MCU14-3
	12.70	12.70	12.70	9.52	9.52	12.70	M2X.4	L1-5	MCU13-4	MCU14-4
	3.995	3.995	3.995	3.995	3.995	5.995	M2X.4	L1-6	MCU13-5	MCU14-5
	9.52	9.52	9.52	9.52	9.52	12.70	M2X.4	L1-5	MCU13-6	MCU14-6
	5.995	5.995	5.995	5.995	5.995	9.52	M3X.5	L1-6	MCU13-7	MCU14-7

MINIATURE OLDHAM COUPLINGS

1/8", 3/16", and 1/4" Bores and 3, 4, 6 mm Bores

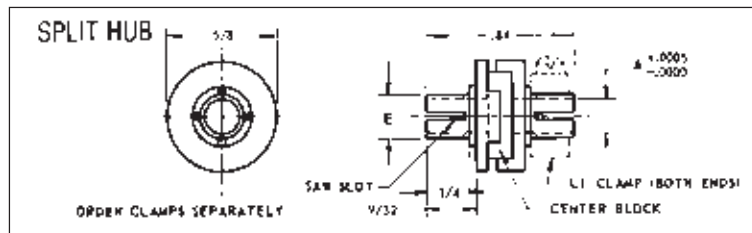
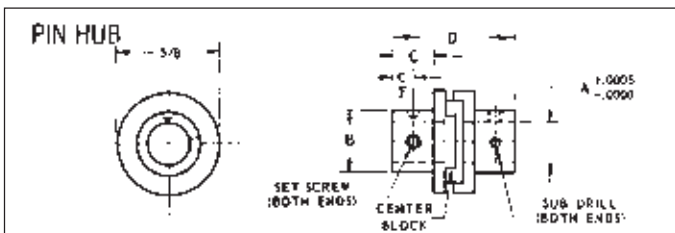

Material:
Hubs — 303 Stainless Steel
Center Block — Oil-impregnated Bronze
For Nylon, add - N to Part Number

***SPECIFICATIONS**
Torque 500 oz. in.
Shaft to Shaft Misalignment .008
Angular Misalignment 1°
Max. Backlash .10"
Max. Speed 1000 rpm

Inch Bores	Shaft Size	A	B	C	D	E	Set Screw	Clamp No. (Rel.)	Pin Hub Part No.	Split Hub Part No.
Toler. +.0005 - .0000	1/8 to 1/8	.1248	5/16	3/16	21/32	.188	#2-56	L1-4	T7-1	T8-1
	1/8 to 3/16	.1248 .1873	5/16 3/8	3/16 7/32	11/16	.188 250	#2-56 #4-40	L1-4 L1-5	T7-5	T8-5
	1/8 to 1/4	.1248 .2498	5/16 1/2	3/16 1/4	23/32	.188 .312	#2-56 #6-32	L1-4 L1-6	T7-6	T8-6
	3/16 to 3/16	.1873	3/8	7/32	23/32	250	#4-40	L1-5	T7-2	T8-2
	3/16 to 1/4	.1873 .2498	3/8 1/2	7/32 1/4	3/4	.250 .312	#4-40 #6-32	L1-5 L1-6	T7-7	T8-7
	1/4 to 1/4	.2498	1/2	1/4	25/32	312	#6-32	L1-6	T7-3	T8-3

Dimensions below are in millimeters.

Metric Bores	3 to 3	3 to 4	3 to 6	4 to 4	4 to 6	6 to 6	Set Screw	Clamp No. (Rel.)	Pin Hub Part No.	Split Hub Part No.
Toler. +.013 - .000	2.995	2.995	2.995	3.995	3.995	5.995	M2X.4	L1-4	MCU9-1	MCU10-1
	7.92	7.92	7.92	9.52	9.52	12.70	M2X.4	L1-4	MCU9-2	MCU10-2
	5.995	5.995	5.995	3.995	3.995	5.995	M2X.4	L1-6	MCU9-3	MCU10-3
	12.70	12.70	12.70	9.52	9.52	12.70	M2X.4	L1-5	MCU9-4	MCU10-4
	3.995	3.995	3.995	3.995	3.995	5.995	M2X.4	L1-6	MCU9-5	MCU10-5
	9.52	9.52	9.52	9.52	9.52	12.70	M2X.4	L1-5	MCU9-6	MCU10-6
	5.995	5.995	5.995	5.995	5.995	9.52	M3X.5	L1-6	MCU9-7	MCU10-7

PRECISION SLEEVE COUPLINGS

1/8" to 1/2" Bores and 3 to 12 mm Bores

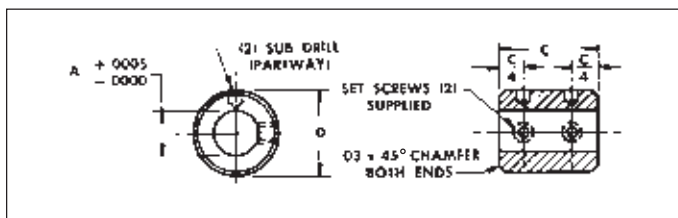

Inch Bores Toler. +.0005 - .0000	Shaft Size	A	C	D	Set Screw	Part No.
	1/8	.1248	.43	5/16	# 2-56	D1-1
	3/16	.1873	.50	3/8	# 4-40	D1-2
	1/4	.2498	.56	1/2	# 6-32	D1-3
	5/16	.3123	.56	9/16	# 6-32	D1-12
	3/8	.3748	.75	3/4	#10-32	D1-13
	1/2	.4998	1.00	1	1/4-20	D1-14

Material: 303 Stainless Steel

Dimensions below are in millimeters.

Metric Bores Toler. +.025 - .000						
	3	2.995	10.92	7.92	M2X.4	MCU5-1
	4	3.995	12.70	9.52	M3X.5	MCU5-2
	5	4.995	12.70	9.52	M3X.5	MCU5-3
	6	5.995	14.29	12.70	M3X.5	MCU5-4
	8	7.995	14.29	14.29	M4X.7	MCU5-5
	10	9.995	19.05	19.05	M5X.8	MCU5-6
	12	11.995	25.40	25.40	M6X1.0	MCU5-7

PRECISION SLEEVE COUPLINGS

1/8" to 3/8" Bores and 3 to 12 mm Bores

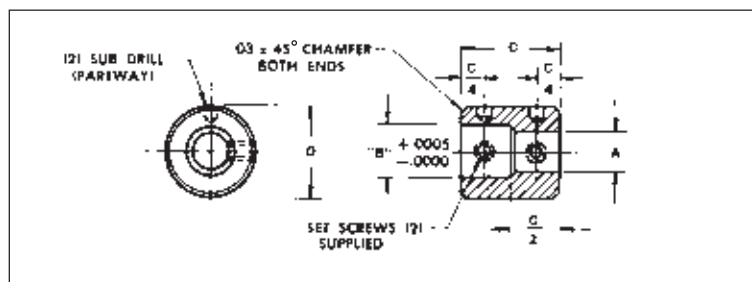

Material: 303 Stainless Steel

Shaft Size (Inch to mm)	Inch to Metric Couplings				Part No.
	A* Inch	B** mm	C mm	D mm	
1/8 to 3	.1248	2.995	19.05	12.70	MCU20-1
1/8 to 4	.1248	3.995	19.05	12.70	MCU20-2
1/8 to 5	.1248	4.995	19.05	12.70	MCU20-3
1/8 to 6	.1248	5.995	19.05	12.70	MCU20-4
3/16 to 3	.1873	2.995	19.05	12.70	MCU20-5
3/16 to 4	.1873	3.995	19.05	12.70	MCU20-6
3/16 to 5	.1873	4.995	19.05	12.70	MCU20-7
3/16 to 6	.1873	5.995	19.05	12.70	MCU20-8
3/16 to 8	.1873	7.995	25.40	19.05	MCU20-9
1/4 to 4	.2498	3.995	19.05	12.70	MCU20-10
1/4 to 5	.2498	4.995	19.05	12.70	MCU20-11
1/4 to 6	.2498	5.995	19.05	12.70	MCU20-12
1/4 to 8	.2498	7.995	25.40	19.05	MCU20-13
1/4 to 10	.2498	9.995	25.40	25.40	MCU20-14
1/4 to 12	.2498	11.995	25.40	25.40	MCU20-15
5/16 to 4	.3123	3.995	25.40	14.22	MCU20-16
5/16 to 5	.3123	4.995	25.40	14.22	MCU20-17
5/16 to 6	.3123	5.995	25.40	14.22	MCU20-18
5/16 to 8	.3123	7.995	25.40	19.05	MCU20-19
5/16 to 10	.3123	9.995	25.40	25.40	MCU20-20
5/16 to 12	.3123	11.995	25.40	25.40	MCU20-21
3/8 to 4	.3748	3.995	25.40	19.05	MCU20-22
3/8 to 5	.3748	4.995	25.40	19.05	MCU20-23
3/8 to 6	.3748	5.995	25.40	19.05	MCU20-24
3/8 to 8	.3748	7.995	25.40	19.05	MCU20-25
3/8 to 10	.3748	9.995	25.40	25.40	MCU20-26
3/8 to 12	.3748	11.995	25.40	25.40	MCU20-27

Inch Bores Toler. +.0005 - .0000	Shaft Size	A	B	D	C	Set Screw	Part No.
	1/8 to 3/16	.1248	.1873	3/8	.50	# 2-56 # 4-40	D1-9
	1/8 to 1/4	.1248	.2498	1/2	.56	# 2-56 # 6-32	D1-10
	3/16 to 1/4	.1873	.2498	1/2	.56	# 4-40 # 6-32	D1-11
	1/4 to 3/8	.2498	.3748	3/4	.75	# 6-32 #10-32	D1-16

Dimensions below are in millimeters.

Metric Bores Toler. +.013 - .000							
	3 to 4	2.995	3.995	9.52	12.70	M2X.4	MCU6-1
	3 to 6	2.995	5.995	12.70	14.29	M2X.4	MCU6-2
	4 to 6	3.995	5.995	12.70	14.29	M3X.5	MCU6-3
	6 to 8	5.995	7.995	14.29	14.29	M3X.5	MCU6-4
	6 to 10	5.995	9.995	19.05	19.05	M3X.5	MCU6-5
	8 to 10	7.995	9.995	19.05	19.05	M4X.7	MCU6-6
10 to 12	9.995	11.995	25.40	25.40	M5X.8	MCU6-7	

*Inch Bores Toler. +.0005, -.0000
**Metric Bores Toler. +.013, -.0000

FLEXIBLE-ZERO BACKLASH COUPLING

1/8" to 5/8" Diameter Bores and 4 mm to 12 mm Bores

This Flexible-Zero Backlash Coupling is designed for applications such as drive systems for lead screws, gear boxes, high performance motion control systems for greater system accuracy and reliability.

- Coupling with integral clamp
- High torsional stiffness
- Low radial losses
- One piece construction
- Constant velocity
- Dynamic torque ratings are momentary values. For non-reversing applications divide by 2, divide by 4 for reversing applications.

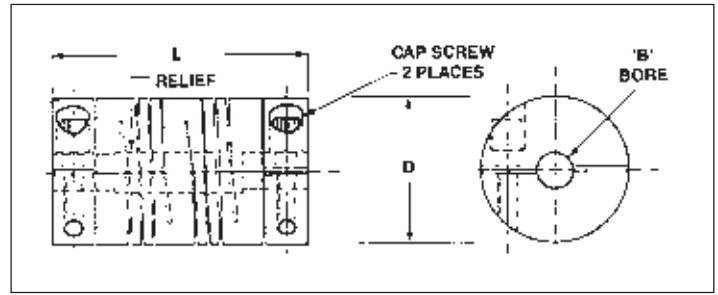

Material 7075-T6 Aluminum, Clear Anodize
or
17-4 PH Stainless Steel

B Bore +.002 -.000	L Length ±.016	D Dia. ±.016	Integral Clamp Screw Size	Momentary Dynamic Torque Inch Lbs.	Torsional Rate (Degree/Lb In)	Misalignment Tolerances			Part Number
						Angular (Degree)	Parallel Offset (Inches)	Axial Motion (Inches)	
.125	0.750	0.500	1-72	7	0.48	5	.010	±.010	T22S-12
.188	1.250	0.750	4-40	14	0.30	3	.010	±.008	T22A-18
.188	0.900	0.750	4-40	20	0.16	5	.010	±.010	T22S-18
.188/.250	1.060	0.875	6-32	34	0.086	5	0.03	±0.01	T22S-1825S
.250	1.500	1.000	6-32	31	0.13	3	.010	±.008	T22A-25
.250	1.250	1.000	6-32	52	0.062	5	.010	±.010	T22S-25
.250	1.750	1.000	6-32	51	0.098	5	.03	±.010	T22S-25S
.250/.125	0.900	0.750	4-40	8.6	0.68	5	.010	±.010	T22A-2512
.250/.188	1.060	0.875	6-32	17	0.28	5	.010	±.010	T22A-2518
.250/.188	1.250	0.750	4-40	12	0.40	3	.010	±.008	T22A-2518D
.250/.375	1.500	1.000	6-32	25	0.19	3	.010	±.008	T22A-2537
.313	1.500	1.000	6-32	29	0.16	3	.010	±.008	T22A-31
.313	1.250	1.000	6-32	47	0.086	5	.010	±.010	T22S-31
.313/.250	1.750	1.000	6-32	46	0.14	5	0.03	±0.01	T22S-2531
.313/.375	2.375	1.250	10-32	91	0.062	5	0.03	±0.01	T22S-3137
.375	1.750	1.250	10-24	58	0.08	3	.010	±.008	T22A-37
.375	2.375	1.250	10-32	91	0.062	5	.030	±.010	T22S-37
.500	2.250	1.500	10-24	115	0.042	3	.010	±.008	T22A-50
.500	2.625	1.500	10-32	170	0.037	5	.030	±.010	T22S-50
.625	2.500	2.000	1/4-20	215	0.020	3	.010	±.008	T22A-62
.625	3.000	2.000	1/4-28	319	0.018	5	.030	±.010	T22S-62

Dimensions Below are in Millimeters

B Bore +.025 -.000	L ± .40	D ± .40	Screw Size	Nm	Degree/Nm	Misalignment Tolerances			Part Number
						Angular (Degree)	Parallel Offset (Inches)	Axial Motion (Inches)	
3.17	19.05	12.70	1-72	.80	0.054	5	.254	±.254	T22S-12
5.00	38.10	25.40	6-32	3.50	0.015	3	.254	±.203	MT22A-05
5.00	31.75	25.40	6-32	5.88	0.007	5	.254	±.254	MT22S-05
6.00	44.45	31.75	10-24	6.55	0.009	3	.254	±.203	MT22A-06
8.00	60.32	31.75	10-32	10.28	0.007	5	.762	±.254	MT22S-08
10.00	57.15	38.10	10-24	13.00	0.005	3	.254	±.203	MT22A-10
10.00	66.67	38.10	10-32	19.21	0.004	5	.762	±.254	MT22S-10
12.00	63.50	50.80	1/4-20	24.30	0.002	3	.254	±.203	MT22A-12
12.00	76.20	50.80	1/4-28	36.05	0.002	5	.762	±.254	MT22S-12

NOTE: 1. Metric Bore sizes are accomplished by using aluminum bore reducers
2. T22A-XX denotes aluminum. T22S-XX denotes stainless steel.

(K) FLEXIBLE COUPLINGS

ILLUSTRATION 1

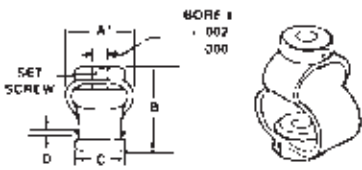
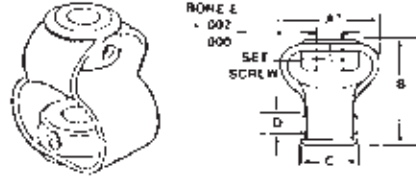

ILLUSTRATION 2



Material: Hubs — Zinc Plated Steel
Body — Polyurethane

FEATURES

Hub:

- Zinc plating resists corrosion
- Inside hub reduces overall length
- Rounded corners prevent cutting
- Annealed steel for maximum strength
- Precision swaged mechanical crimp
- Standard size set screws
- AGMA Class 2 bore tolerance: $-.000 + .002$

Flexible Element:

- Maximum flexibility because of unique design
- Polyurethane is durable, flexible, cut-and-wear resistant
- Greater radius for added strength
- Full wrap-around design stays securely in hub
- Non-standard bore combinations available...inquire for price and availability

NOTE: Maximum operating speed is 3600 RPM.

Illustration	Dimensions					Set Screw	Capacity (in. lbs.)	Maximum Angular Misalignment	Max. Lateral Misalignment (inch)	Part No.
	A*	B	C	D	E					
1	1-1/8	1-1/8	1-1/8	2-1/8	.68	#6-32	3	10°	3/32	T21-3
				2-1/4	1.12					T21-4
				2-3/8	1.75					T21-5
				2-1/2	2.37					T21-6
2	1-3/8	1-3/4	1	3-3/8	.250	#10-24	12	15°	1/8	T22-4
				3-1/2	.312					T22-5
				3-3/4	.375					T22-6
				4-1/8	.438					T22-7
				4-1/4	.500					T22-8
				4-3/8	.562					T22-9
2	2-1/8	2-1/8	1-1/8	7-1/16	.375	#1/4-20	28	15°	3/16	T23-6
				7-1/8	.438					T23-7
				7-1/4	.500					T23-8
				7-3/8	.562					T23-9
2	2-1/8	2-1/8	1-1/8	3-3/8	.500	#1/4-20	40	5°	1/8	T24-8
				3-1/2	.625					T24-9

*Dimensions at widest point

BORE REDUCERS

Inch And Metric

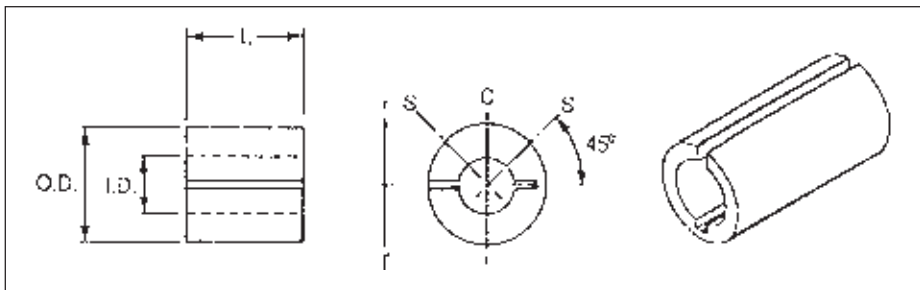

Material: Aluminum

Inch to inch and inch to metric bore reducers adapt a coupling, clutch, pulley and other bores to a number of shaft diameters when fitted to a pin hub (set screw) or split hubs.

Grip relies on adequate contact area between the shaft and reducer.

Release of residual stresses after slitting may result in slight springing of the material, — this can be corrected by finger pressure.

For optimum fastening install bore reducers as shown:

"S" = Two Set Screw Position

"C" = One Set Screw

"T" = Tangential Screw In Clamp Hub

Inch to Inch Reduction

OD +.0005 -.001	ID +.001 -.000	L ±.010	Part No.
.250	.125	3/8	R-04-02-375
.250	.187	3/8	R-04-03-375
.375	.250	1/2	R-06-04-500
.375	.3125	1/2	R-06-05-500
.500	.375	1/2	R-08-06-750

Inch to Metric Reduction

OD +.0005 -.001	ID +.025 -.000 (mm)	L ±.25 (mm)	Part No.
.250	5	8 (.312)	MR-04-05-08
.375	6	11 (.433)	MR-06-06-11
.375	8	12 (.472)	MR-06-08-12
.500	10	16 (.625)	MR-08-10-16
.625	12	16 (.625)	MR-10-12-12

Bore Reducers With Thicker Walls May Have Slot In Opposite Wall For Proper Flexibility.

PRECISION UNIVERSAL JOINTS

1/8", 3/16", and 1/4" Bores and 3, 4, 6 mm Bores

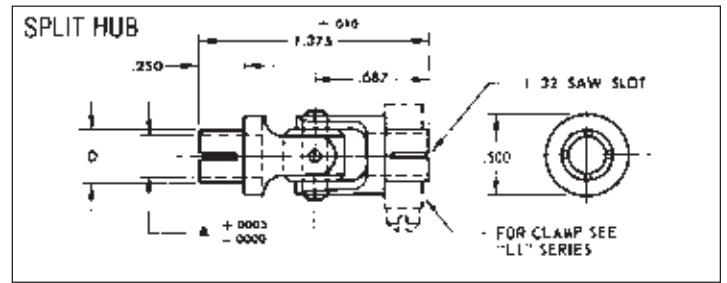
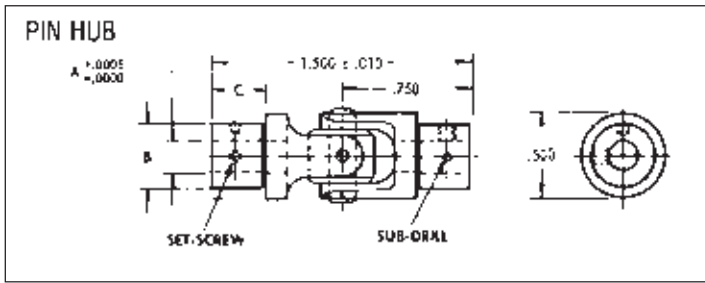

Material: 303 Stainless Steel

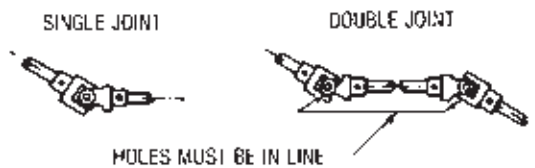

Inch Bores	Shaft Size	A	B	C	D	Set Screw	Clamp No. (Ref.)	Pin Hub Part No.	Split Hub Part No.
Toler. +.0005	1/8	.1248	.312	.312	.188	#2-56	L1-4	BC-1	BC-10
-.0000	3/16	.1873	.375	.312	.250	#4-40	L1-5	BC-2	BC-11
	1/4	.2498	.500	-	.312	#6-32	L1-6	BC-3	BC-12

Dimensions below are in millimeters.

Metric Bores	A	B	C	D	Set Screw	Clamp No. (Ref.)	Pin Hub Part No.	Split Hub Part No.
Toler. +.013	3	2.995	7.92	7.92	4.78	L1-4	MUJ3-1	MUJ4-1
-.000	4	3.995	9.52	7.92	6.35	L1-5	MUJ3-2	MUJ4-2
	6	5.995	12.70	7.92	7.92	L1-6	MUJ3-3	MUJ4-3

Universal joints will operate at angles up to 30°. For most efficient operation, operate at a maximum angle of 10°. Lubrication required.
Maximum speed: 300 RPM

MOLDED UNIVERSAL JOINTS

1/8", 3/16", and 1/4" Bores and 3, 4, 6 mm Bores

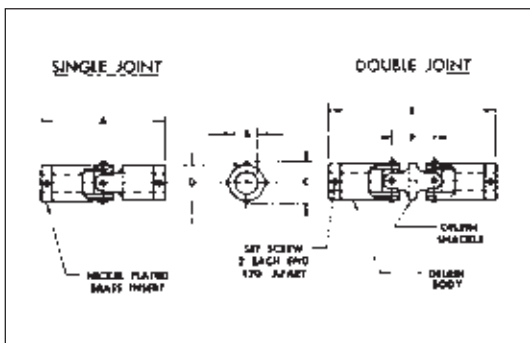

Type	B	A	C	D	E	F	Set Screw	Part No.
Inch Bores Toler. +.001 - .000	1/8 to 3/16	1.31/64	7/16	3/8	-	-	#2-56 #4-40	BC-21
	3/16	1.31/64	7/16	3/8	-	-	#4-40	BC-22
	3/16 to 1/4	1.13/16	9/16	1/2	-	-	#4-40 #6-32	BC-24
Double Joint	1/4	1.13/16	9/16	1/2	-	-	#6-32	BC-25
	3/16	-	7/16	3/8	2	33/64	#4-40	BC-32
	1/4	-	9/16	1/2	2-7/16	5/8	#6-32	BC-35

Dimensions below are in millimeters.

Metric Bores Toler. +.025 - .000	B	A	C	D	E	F	Set Screw	Part No.
Single Joint	3 to 3	37.70	11.11	9.52	-	-	M2X.4	MUJ2-1
	3 to 4	37.70	11.11	9.52	-	-	M2X.4	MUJ2-2
	4 to 4	37.70	11.11	9.52	-	-	M2X.4	MUJ2-3
	4 to 6	46.04	14.29	12.70	-	-	M2X.4	MUJ2-4
Double Joint	6 to 6	46.04	14.29	12.70	-	-	M3X.5	MUJ2-5
	3 to 3	-	11.11	9.52	50.8	13.10	M2X.4	MUJ2-6
	3 to 4	-	11.11	9.52	50.8	13.10	M2X.4	MUJ2-7
	4 to 4	-	11.11	9.52	50.8	13.10	M2X.4	MUJ2-8
	4 to 6	-	14.29	12.70	61.9	15.88	M2X.4	MUJ2-9
	6 to 6	-	14.29	12.70	61.9	15.88	M3X.5	MUJ2-10

C		Capac. Oz-in.*	
In.	mm	Cont.	Manual
7/16	(11.11)	25	50
9/16	(14.29)	85	170

*Based on 3.5° max. allowable deflection for continuous operation and 7° for manual operation. Double joints have one half of these capacities.











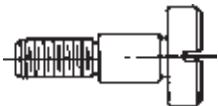
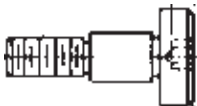
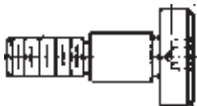
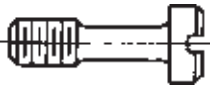

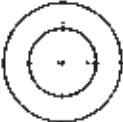

Max. shaft angles are 10° for 2000 rpm, 15° for 1500 rpm, 20° for 1000 rpm and 30° for 500 rpm.

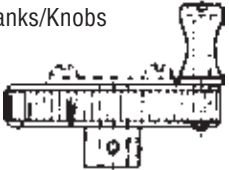
PIC Design offers an extensive line of precision Hardware which contains various items for fastening and/or locating of precision industrial components. The hardware is manufactured from Stainless Steel to the PIC high quality standards, in either inch or metric styles of thread, diameter and length.

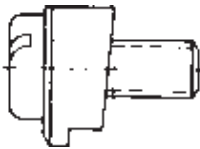
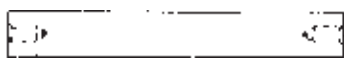
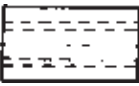
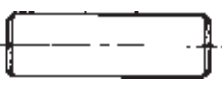
The following pages have been included as a technical guide to aid the designer or engineer in selecting the appropriate screw type and size. The drill and tap data in inch for both the UNF and the UNC pieces,

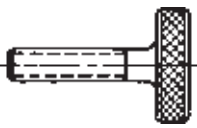
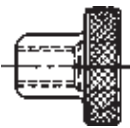
selects the correct drill to be used for the appropriate tap. For the metric ISO thread, the correct drill is recommended for the thread size and pitch.

The screw head detail data for both inch and metric heads enables the designer to select the appropriate type of head required and to allow for the clearance of the heads.

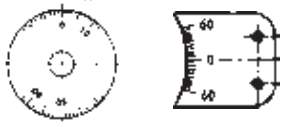
Slotted head shoulder screws. 	Socket head shoulder screws. 	Phillips head shoulder screws. 	Captive Screws 
No-Mar set screws 	Silver-Grip set screws 	Cup point set screws 	Brass tip set screws 
Precision washers 	Belleville spring washers 	Curved washers 	Cranks/Knobs 
Retaining rings 	Motor mount cleats 	Spacers 	Standoffs 
Dowel pins 	Woodruff keys 	Knurled thumb screws 	Knurled thumb nuts 
Swivel studs, nuts and washers 	Handles 	Springs 	Dials and verniers 

SLOTTED HEAD SHOULDER SCREWS

303 & Hardened 416 Stainless Steel

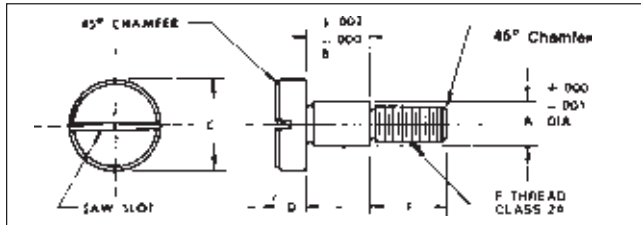

Material: 303 Stainless Steel — 43XX
416 Stainless Steel — 45XX (Hardness 26-32 RC)

A	B	C	D	E	F	303 P / N	416 P / N
1/8 .1245	1/8-.1255	1/4	1/8	# 4-40	5/32	4310	4510
	3/16-.1880					4311	4511
	1/4-.2505					4312	4512
	5/16-.3130					4313	4513
	3/8-.3755					4314	4514
5/32 .1557	1/8-.1255	9/32	1/8	# 6-32	3/16	4361	4561
	3/16-.1880					4362	4562
	1/4-.2505					4363	4563
	5/16-.3130					4364	4564
	3/8-.3755					4365	4565
3/16 .1870	1/8-.1255	5/16	5/32	# 8-32	3/16	4315	4515
	3/16-.1880					4316	4516
	1/4-.2505					4317	4517
	5/16-.3130					4318	4518
	3/8-.3755					4319	4519
	1/2-.5005					4320	4520
	5/8-.6255					4321	4521
	3/4-.7505					4322	4522
	1 - 1.0005					4323	4523
	1-1/4-1.2505					4324	4524
1-1/2-1.5005	4325	4525					

A	B	C	D	E	F	303 P / N	416 P / N
1/4 .2495	1/8-.1255	3/8	3/16	# 10-32	1/4	4326	4526
	3/16-.1880					4327	4527
	1/4-.2505					4328	4528
	5/16-.3130					4329	4529
	3/8-.3755					4330	4530
	1/2-.5005					4331	4531
	5/8-.6255					4332	4532
	3/4-.7505					4333	4533
	1 - 1.0005					4334	4534
	1-1/4-1.2505					4335	4535
1-1/2-1.5005	4336	4536					
5/16 .3120	1/4-.2505	1/2	7/32	1/4-20	7/16	4337	4537
	5/16-.3130					4338	4538
	3/8-.3755					4339	4539
	1/2-.5005					4340	4540
	5/8-.6255					4341	4541
3/4-.7505	4342	4542					
3/8 .3745	5/16-.3130	1/2	7/32	1/4-20	7/16	4343	4543
	3/8-.3755					4344	4544
	1/2-.5005					4345	4545
	5/8-.6255					4346	4546
3/8 .3745	5/16-.3130	9/16	1/4	5/16-18	1/2	4347	4547
	3/8-.3755					4348	4548
	1/2-.5005					4349	4549
	5/8-.6255					4350	4550
1/2 .4995	1/2-.5005	3/4	5/16	3/8-16	5/8	4351	4551
	5/8-.6255					4352	4552
	3/4-.7505					4353	4553
	1 - 1.0005					4354	4554

Shoulder Screw Kits			Qty.	303 P / N	416 P / N
Shoulder Screws — Stainless Steel — Slotted and Socket Head. Assorted Lengths for shoulder dia. of 1/8" and thread of # 4-40	50	Y34K	Y37K		
Shoulder Screws — Stainless Steel — Slotted and Socket Head. Assorted Lengths for shoulder dia. of 3/16" and thread of # 8-32	50	Y35K	Y38K		
Shoulder Screws — Stainless Steel — Slotted and Socket Head. Assorted Lengths for shoulder dia. of 1/4" and thread of # 10-32	50	Y36K	Y39K		

METRIC SLOTTED HEAD SHOULDER SCREWS

303 & Hardened 416 Stainless Steel

All Dimensions in Millimeters

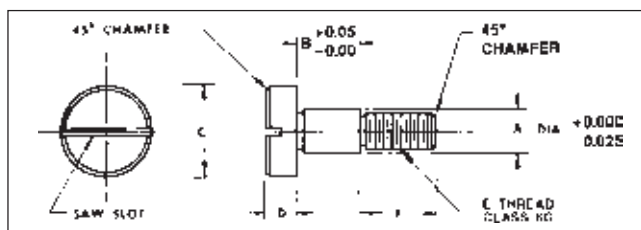

Material: 303 Stainless Steel — MSB1-XX
416 Stainless Steel — MSB3-XX (Hardness 26-32 RC)

A	B	C	D	E	F	303 P / N	416 P / N
3.987 (4)	4.013 (4)	6	3	M3 x 0.5	4	MSB1-1	MSB3-1
	5.013 (5)					MSB1-2	MSB3-2
	6.013 (6)					MSB1-3	MSB3-3
	8.013 (8)					MSB1-4	MSB3-4
	10.013 (10)					MSB1-5	MSB3-5
4.987 (5)	4.013 (4)	8	4	M4 x 0.7	5	MSB1-6	MSB3-6
	5.013 (5)					MSB1-7	MSB3-7
	6.013 (6)					MSB1-8	MSB3-8
	8.013 (8)					MSB1-9	MSB3-9
	10.013 (10)					MSB1-10	MSB3-10
	12.013 (12)					MSB1-11	MSB3-11
	14.013 (14)					MSB1-12	MSB3-12
	16.013 (16)					MSB1-13	MSB3-13
	20.013 (20)					MSB1-14	MSB3-14
	25.013 (25)					MSB1-15	MSB3-15
30.013 (30)	MSB1-16	MSB3-16					
5.987 (6)	4.013 (4)	10	5	M5 x 0.8	6	MSB1-17	MSB3-17
	5.013 (5)					MSB1-18	MSB3-18
	6.013 (6)					MSB1-19	MSB3-19
	8.013 (8)					MSB1-20	MSB3-20

A	B	C	D	E	F	303 P / N	416 P / N
5.987 (6)	10.013 (10)	10	5	M5 x 0.8	6	MSB1-21	MSB3-21
	12.013 (12)					MSB1-22	MSB3-22
	14.013 (14)					MSB1-23	MSB3-23
	16.013 (16)					MSB1-24	MSB3-24
	20.013 (20)					MSB1-25	MSB3-25
	25.013 (25)					MSB1-26	MSB3-26
	30.013 (30)					MSB1-27	MSB3-27
7.987 (8)	6.013 (6)	12	6	M6 x 1	11	MSB1-28	MSB3-28
	8.013 (8)					MSB1-29	MSB3-29
	10.013 (10)					MSB1-30	MSB3-30
	12.013 (12)					MSB1-31	MSB3-31
	16.013 (16)					MSB1-32	MSB3-32
20.013 (20)	MSB1-33	MSB3-33					
9.987 (10)	8.013 (8)	12	6	M6 x 1	11	MSB1-34	MSB3-34
	10.013 (10)					MSB1-35	MSB3-35
	12.013 (12)					MSB1-36	MSB3-36
	16.013 (16)					MSB1-37	MSB3-37
9.987 (10)	8.013 (8)	14	7	M8 x 1.25	12	MSB1-38	MSB3-38
	10.013 (10)					MSB1-39	MSB3-39
	12.013 (12)					MSB1-40	MSB3-40
	16.013 (16)					MSB1-41	MSB3-41
11.987 (12)	12.013 (12)	20	8	M10 x 1.5	16	MSB1-42	MSB3-42
	16.013 (16)					MSB1-43	MSB3-43
	20.013 (20)					MSB1-44	MSB3-44
	25.013 (25)					MSB1-45	MSB3-45

Shoulder Screw Kits			Qty.	303 P / N	416 P / N
Shoulder Screws — Stainless Steel — Slotted and Socket Head. Assorted Lengths for shoulder dia. of 4mm and thread of M3 x 0.5	50	MAK19	MAK22		
Shoulder Screws — Stainless Steel — Slotted and Socket Head. Assorted Lengths for shoulder dia. of 5mm and thread of M4 x 0.7	50	MAK20	MAK23		
Shoulder Screws — Stainless Steel — Slotted and Socket Head. Assorted Lengths for shoulder dia. of 6mm and thread of M5 x 0.8	50	MAK21	MAK24		

(continued)

SOCKET HEAD SHOULDER SCREWS

303 & Hardened 416 Stainless Steel — Inch

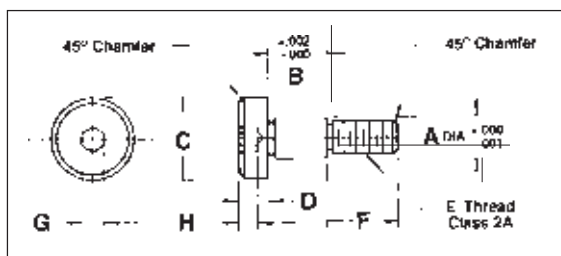

Material: 303 Stainless Steel — 44XX
416 Stainless Steel — 46XX (Hardness 26-32 RC)

A	B	C	D	E	F	G	H (min.)	303 P / N	416 P / N
1/8 .1245	1/8- .1255	1/4	1/8	# 4-40	5/32	5/64	1/16	4410	4610
	3/16- .1880							4411	4611
	1/4- .2505							4412	4612
	5/16- .3130							4413	4613
	3/8- .3755							4414	4614
5/32 .1557	1/8- .1255	9/32	1/8	# 6-32	3/16	3/32	5/64	4461	4661
	3/16- .1880							4462	4662
	1/4- .2505							4463	4663
	5/16- .3130							4464	4664
	3/8- .3755							4465	4665
3/16 .1870	1/8- .1255	5/16	5/32	# 8-32	3/16	3/32	5/64	4415	4615
	3/16- .1880							4416	4616
	1/4- .2505							4417	4617
	5/16- .3130							4418	4618
	3/8- .3755							4419	4619
	1/2- .5005							4420	4620
	5/8- .6255							4421	4621
	3/4- .7505							4422	4622
	1 - 1.0005							4423	4623
	1-1/4- 1.2505							4424	4624
	1-1/2- 1.5005							4425	4625

A	B	C	D	E	F	G	H (min.)	303 P / N	416 P / N
1/4 .2495	1/8- .1255	3/8	3/16	# 10-32	1/4	1/8	3/32	4426	4626
	3/16- .1880							4427	4627
	1/4- .2505							4428	4628
	5/16- .3130							4429	4629
	3/8- .3755							4430	4630
	1/2- .5005							4431	4631
	5/8- .6255							4432	4632
	3/4- .7505							4433	4633
	1 - 1.0005							4434	4634
	1-1/4- 1.2505							4435	4635
	1-1/2- 1.5005							4436	4636
5/16 .3120	1/4- .2505	1/2	7/32	1/4-20	7/16	5/32	1/8	4437	4637
	5/16- .3130							4438	4638
	3/8- .3755							4439	4639
	1/2- .5005							4440	4640
	5/8- .6255							4441	4641
3/8 .3745	5/16- .3130	1/2	7/32	1/4-20	7/16	5/32	1/8	4443	4643
	3/8- .3755							4444	4644
	1/2- .5005							4445	4645
	5/8- .6255							4446	4646
3/8 .3745	5/16- .3130	9/16	1/4	5/16-18	1/2	3/16	5/32	4447	4647
	3/8- .3755							4448	4648
	1/2- .5005							4449	4649
1/2 .4995	5/8- .6255	3/4	5/16	3/8-16	5/8	1/4	3/16	4451	4651
	3/4- .7505							4452	4652
	1 - 1.0005							4453	4653
	1-1/2- 1.5005							4454	4654

Shoulder Screw Kits			Qty.	303 P / N	416 P / N
Shoulder Screws — Stainless Steel — Slotted and Socket Head. Assorted Lengths for shoulder dia. of 1/8" and thread of # 4-40.			50	Y34K	Y37K
Shoulder Screws — Stainless Steel — Slotted and Socket Head. Assorted Lengths for shoulder dia. of 3/16" and thread of # 8-32.			50	Y35K	Y38K
Shoulder Screws — Stainless Steel — Slotted and Socket Head. Assorted Lengths for shoulder dia. of 1/4" and thread of # 10-32.			50	Y36K	Y39K

303 & Hardened 416 Stainless Steel — Metric

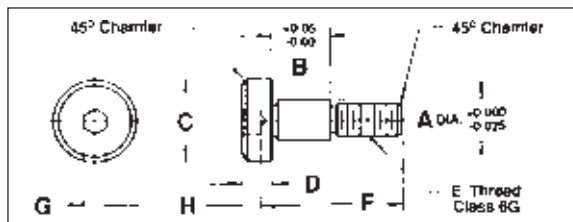

Material: 303 Stainless Steel — MSB2-XX
416 Stainless Steel — MSB4-XX (Hardness 26-32 RC)

A	B	C	D	E	F	G	H (min.)	303 P / N	416 P / N
3.987 (4)	4.013 (4)	6	3	M3 x 0.5	4	2	1.6	MSB2-1	MSB4-1
	5.013 (5)							MSB2-2	MSB4-2
	6.013 (6)							MSB2-3	MSB4-3
	8.013 (8)							MSB2-4	MSB4-4
	10.013 (10)							MSB2-5	MSB4-5
4.987 (5)	4.013 (4)	8	4	M4 x 0.7	5	2.5	2	MSB2-6	MSB4-6
	5.013 (5)							MSB2-7	MSB4-7
	6.013 (6)							MSB2-8	MSB4-8
	8.013 (8)							MSB2-9	MSB4-9
	10.013 (10)							MSB2-10	MSB4-10
	12.013 (12)							MSB2-11	MSB4-11
	14.013 (14)							MSB2-12	MSB4-12
	16.013 (16)							MSB2-13	MSB4-13
	20.013 (20)							MSB2-14	MSB4-14
	25.013 (25)							MSB2-15	MSB4-15
	30.013 (30)							MSB2-16	MSB4-16
5.987 (6)	4.013 (4)	10	5	M5 x 0.8	6	3	2.4	MSB2-17	MSB4-17
	5.013 (5)							MSB2-18	MSB4-18
	6.013 (6)							MSB2-19	MSB4-19
	8.013 (8)							MSB2-20	MSB4-20

A	B	C	D	E	F	G	H (min.)	303 P / N	416 P / N
5.987 (6)	10.013 (10)	10	5	M5 x 0.8	6	3	2.4	MSB2-21	MSB4-21
	12.013 (12)							MSB2-22	MSB4-22
	14.013 (14)							MSB2-23	MSB4-23
	16.013 (16)							MSB2-24	MSB4-24
	20.013 (20)							MSB2-25	MSB4-25
	25.013 (25)							MSB2-26	MSB4-26
7.987 (8)	6.013 (6)	12	6	M6 x 1	11	4	3.2	MSB2-28	MSB4-28
	8.013 (8)							MSB2-29	MSB4-29
	10.013 (10)							MSB2-30	MSB4-30
	12.013 (12)							MSB2-31	MSB4-31
	16.013 (16)							MSB2-32	MSB4-32
	20.013 (20)							MSB2-33	MSB4-33
9.987 (10)	8.013 (8)	12	6	M6 x 1	11	4	3.2	MSB2-34	MSB4-34
	10.013 (10)							MSB2-35	MSB4-35
	12.013 (12)							MSB2-36	MSB4-36
9.987 (10)	16.013 (16)	12	6	M6 x 1	11	4	3.2	MSB2-37	MSB4-37
	8.013 (8)							MSB2-38	MSB4-38
	10.013 (10)							MSB2-39	MSB4-39
9.987 (10)	12.013 (12)	14	7	M8 x 1.25	12	5	4	MSB2-40	MSB4-40
	16.013 (16)							MSB2-41	MSB4-41
	12.013 (12)							MSB2-42	MSB4-42
	16.013 (16)							MSB2-43	MSB4-43
11.987 (12)	20.013 (20)	20	8	M10 x 1.5	16	6	4.8	MSB2-44	MSB4-44
	25.013 (25)							MSB2-45	MSB4-45

Shoulder Screw Kits			Qty.	303 P / N	416 P / N
Shoulder Screws — Stainless Steel — Slotted and Socket Head. Assorted Lengths for shoulder dia. of 4mm and thread of M3 x 0.5.			50	MAK19	MAK22
Shoulder Screws — Stainless Steel — Slotted and Socket Head. Assorted Lengths for shoulder dia. of 5mm and thread of M4 x 0.7.			50	MAK20	MAK23
Shoulder Screws — Stainless Steel — Slotted and Socket Head. Assorted Lengths for shoulder dia. of 6mm and thread of M5 x 0.8.			50	MAK21	MAK24

PHILLIPS HEAD SHOULDER SCREWS

303 & Hardened 416 Stainless Steel — Inch

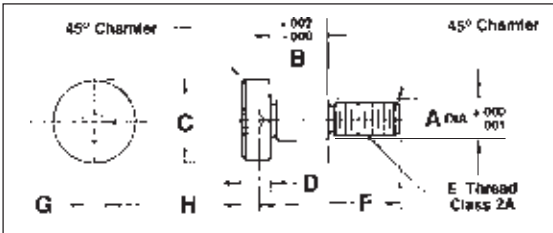

Material: 303 Stainless Steel — 47XX
416 Stainless Steel — 48XX (Hardness 26-32 RC)

A	B	C	D	E	F	*Drive Size	H (min.)	303 P/N	416 P/N	*Drive Size
1/8 .1245	1/8- .1255	1/4	1/8	# 4-40	5/32	1	1/16	4710	4810	1
	3/16- .1880							4711	4811	
	1/4- .2505							4712	4812	
	5/16- .3130							4713	4813	
	3/8- .3755							4714	4814	
3/16 .1870	1/8- .1255	5/16	5/32	# 8-32	3/16	2	5/64	4715	4815	2
	3/16- .1880							4716	4816	
	1/4- .2505							4717	4817	
	5/16- .3130							4718	4818	
	3/8- .3755							4719	4819	
	1/2- .5005							4720	4820	
	5/8- .6255							4721	4821	
	3/4- .7505							4722	4822	
	1 - 1.0005							4723	4823	
	1-1/4- 1.2505							4724	4824	
1-1/2- 1.5005	4725	4825								

A	B	C	D	E	F	*Drive Size	H (min.)	303 P/N	416 P/N	*Drive Size
1/4 .2495	1/8- .1255	3/8	3/16	# 10-32	1/4	2	3/32	4726	4826	2
	3/16- .1880							4727	4827	
	1/4- .2505							4728	4828	
	5/16- .3130							4729	4829	
	3/8- .3755							4730	4830	
	1/2- .5005							4731	4831	
	5/8- .6255							4732	4832	
	3/4- .7505							4733	4833	
	1 - 1.0005							4734	4834	
	1-1/4- 1.2505							4735	4835	
1-1/2- 1.5005	4736	4836								
5/16 .3120	1/4- .2505	1/2	7/32	1/4-20	7/16	3	1/8	4737	4837	3
	5/16- .3130							4738	4838	
	3/8- .3755							4739	4839	
	1/2- .5005							4740	4840	
	5/8- .6255							4741	4841	
3/4- .7505	4742	4842								
3/8 .3745	5/16- .3130	1/2	7/32	1/4-20	7/16	3	1/8	4743	4843	3
	3/8- .3755							4744	4844	
	1/2- .5005							4745	4845	
	5/8- .6255							4746	4846	
3/8 .3745	5/16- .3130	9/16	1/4	5/16-18	1/2	4	5/32	4747	4847	4
	3/8- .3755							4748	4848	
	1/2- .5005							4749	4849	
	5/8- .6255							4750	4850	
1/2 .4995	1/2- .5005	3/4	5/16	3/8-16	5/8	4	3/16	4751	4851	4
	5/8- .6255							4752	4852	
	3/4- .7505							4753	4853	
	1 - 1.0005							4754	4854	

303 & Hardened 416 Stainless Steel — Metric

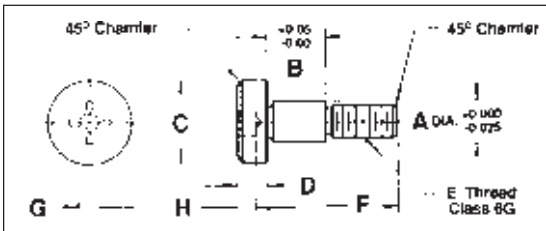

Material: 303 Stainless Steel — MSB7-XX
416 Stainless Steel — MSB8-XX (Hardness 26-32 RC)

A	B	C	D	E	F	*Drive Size	H (min.)	303 P/N	416 P/N	*Drive Size
3.987 (4)	4.013 (4)	6	3	M3 x 0.5	4	1	1.6	MSB7-1	MSB8-1	1
	5.013 (5)							MSB7-2	MSB8-2	
	6.013 (6)							MSB7-3	MSB8-3	
	8.013 (8)							MSB7-4	MSB8-4	
	10.013 (10)							MSB7-5	MSB8-5	
4.987 (5)	4.013 (4)	8	4	M4 x 0.7	5	2	2	MSB7-6	MSB8-6	2
	5.013 (5)							MSB7-7	MSB8-7	
	6.013 (6)							MSB7-8	MSB8-8	
	8.013 (8)							MSB7-9	MSB8-9	
	10.013 (10)							MSB7-10	MSB8-10	
	12.013 (12)							MSB7-11	MSB8-11	
	14.013 (14)							MSB7-12	MSB8-12	
	16.013 (16)							MSB7-13	MSB8-13	
	20.013 (20)							MSB7-14	MSB8-14	
	25.013 (25)							MSB7-15	MSB8-15	
30.013 (30)	MSB7-16	MSB8-16								
5.987 (6)	4.013 (4)	10	5	M5 x 0.8	6	2	2.4	MSB7-17	MSB8-17	2
	5.013 (5)							MSB7-18	MSB8-18	
	6.013 (6)							MSB7-19	MSB8-19	
	8.013 (8)							MSB7-20	MSB8-20	

A	B	C	D	E	F	*Drive Size	H (min.)	303 P/N	416 P/N	*Drive Size
5.987 (6)	10.013 (10)	10	5	M5 x 0.8	6	2	2.4	MSB7-21	MSB8-21	2
	12.013 (12)							MSB7-22	MSB8-22	
	14.013 (14)							MSB7-23	MSB8-23	
	16.013 (16)							MSB7-24	MSB8-24	
	20.013 (20)							MSB7-25	MSB8-25	
	25.013 (25)							MSB7-26	MSB8-26	
30.013 (30)	MSB7-27	MSB8-27								
7.987 (8)	6.013 (6)	12	6	M6 x 1	11	3	3.2	MSB7-28	MSB8-28	3
	8.013 (8)							MSB7-29	MSB8-29	
	10.013 (10)							MSB7-30	MSB8-30	
	12.013 (12)							MSB7-31	MSB8-31	
	16.013 (16)							MSB7-32	MSB8-32	
20.013 (20)	MSB7-33	MSB8-33								
9.987 (10)	8.013 (8)	12	6	M6 x 1	11	3	3.2	MSB7-34	MSB8-34	3
	10.013 (10)							MSB7-35	MSB8-35	
	12.013 (12)							MSB7-36	MSB8-36	
	16.013 (16)							MSB7-37	MSB8-37	
9.987 (10)	8.013 (8)	14	7	M8 x 1.25	12	4	4	MSB7-38	MSB8-38	4
	10.013 (10)							MSB7-39	MSB8-39	
	12.013 (12)							MSB7-40	MSB8-40	
	16.013 (16)							MSB7-41	MSB8-41	
11.987 (12)	12.013 (12)	20	8	M10 x 1.5	16	4	4.8	MSB7-42	MSB8-42	4
	16.013 (16)							MSB7-43	MSB8-43	
	20.013 (20)							MSB7-44	MSB8-44	
	25.013 (25)							MSB7-45	MSB8-45	

"SILVER-GRIP" SET SCREWS

Inch and Metric

How It Works: The "Silver-Grip" Inset

This diagram shows how the principle works. Note the pellet of silver alloy inset into the nose of the gear. The silver is just soft enough so that it adjusts, as you tighten the set screw, to mate with the exact contours of the opposing surface. The silver and shaft are in complete contact with each other over the total surface of the point of the screw. No wonder that no other set screw has greater holding power than the "Silver-Grip".

Never Mars The Opposing Surface

No matter how much torque you apply to the socket head, the "Silver-Grip" set screw will not scratch, mar or deform the opposing surface. When you remove the set screw, the surface will be as smooth as new!

Unscrews Easily

When it's time to re-set, the "Silver Grip" unscrews without creating any problems.

Use It Over And Over

And you can reset the "Silver-Grip" over and over again, with the same perfect results you enjoy the first time you use it. The "Silver-Grip" is ideally suited -- it's a must for any situation where a set screw must be periodically re-set or removed.

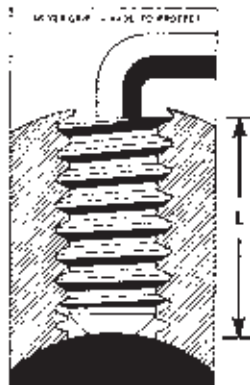

* Nominal Screw length excludes silver tip

300 Series Stainless Steel.
Class 3A Threads

Screw Size	L*	Part No.
# 2-56	1/8	CS-51
# 4-40	1/8	CS-52
	1/4	CS-53
# 6-32	1/8	CS-54
	1/4	CS-55
# 8-32	3/16	CS-56
	3/8	CS-57
#10-32	3/16	CS-59
	3/8	CS-60
1/4 -20	1/4	CS-61
	3/8	CS-62
5/16-18	1/2	CS-64
	3/4	CS-65
3/8 -16	1/2	CS-66
	1	CS-67

"SILVER-GRIP" KITS

Description of Contents	Number of Parts	Part No.
"Silver-Grip" Set Screws-Stainless Steel, Hex Head, Assorted Sizes from #4-40 to #8-32.	75	Y20K
"Silver-Grip" Set Screws-Stainless Steel, Hex Head, Assorted Sizes from #8-32 to 1/4-20.	75	Y21K
"Silver-Grip" Set Screws-Stainless Steel, Hex Head, Assorted Sizes from 1/4-20 to 3/8-16.	75	Y22K

METRIC "SILVER-GRIP" KITS

Description of Contents	Number of Parts	Part No.
"Silver-Grip" Set Screws-Socket Hexagon Type, stainless steel, Assorted lengths in sizes M2 x 0.4 and M3 x 0.5	75	MAK15
"Silver-Grip" Set Screws-Socket, Hexagon Type, stainless steel, Assorted lengths in sizes M4 x 0.7 and M5 x 0.6.	75	MAK16
"Silver-Grip" Set Screws-Socket, Hexagon Type, stainless steel, Assorted lengths in sizes M6 x 1 to M10 x 1.5.	75	MAK17

Dimensions Below Are In Millimeters.

Screw Size	L*	Part No.
M2 x 0.4	3	MSS3-1
	4	MSS3-2
	5	MSS3-3
	6	MSS3-4
M3 x 0.5	3	MSS3-5
	4	MSS3-6
	5	MSS3-7
	6	MSS3-8
M4 x 0.7	4	MSS3-9
	6	MSS3-10
	10	MSS3-11
	14	MSS3-12
M5 x 0.8	6	MSS3-13
	10	MSS3-14
	14	MSS3-15
	20	MSS3-16
M6 x 1	6	MSS3-17
	10	MSS3-18
	16	MSS3-19
	25	MSS3-20
M10 x 1.5	12	MSS3-21
	20	MSS3-22
	30	MSS3-23

"NO-MAR" SET SCREWS

Inch and Metric

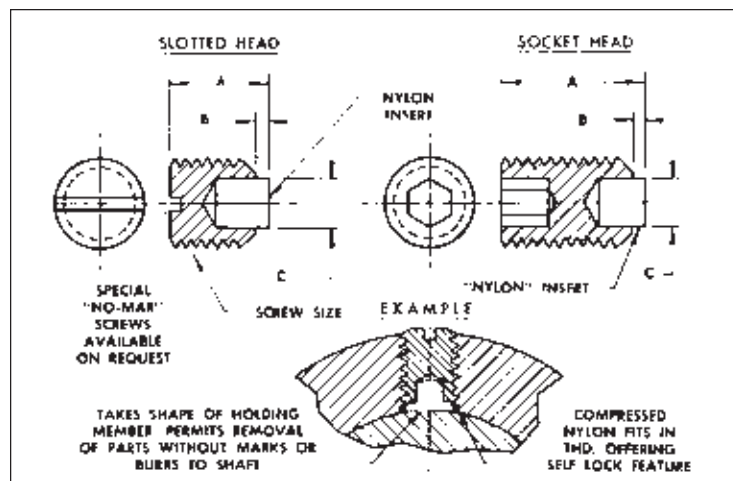

Features:

- "No-Mar" Set Screws are self-locking as expanding nylon insert compresses against shaft and into thread of holding member
- Parts may be assembled or dis-assembled numerous times without damage to the shaft
- "No-Mar" Set Screws afford secure full force contact, regardless of shape of the shaft
- "No-Mar" Set Screws will not scratch, mar or deform the opposing surface

Material: Screw — Stainless Steel Sold in Increments of 10 Pieces.
Insert — Nylon

SOCKET HEAD — Class 3A

Screw Size	A	B	C	Part No.
# 2-56	5/32	1/32	1/32	CS-8
	9/32			CS-24
# 4-40	5/32	1/32	1/16	CS-9
	9/32			CS-25
	13/32			CS-26
# 6-32	5/32	1/32	1/16	CS-10
	9/32			CS-15
	17/32			CS-27
# 8-32	15/64	3/64	3/32	CS-11
	27/64			CS-16
	43/64			CS-28
#10-24	15/64	3/64	3/32	CS-12
	27/64			CS-17
#10-32	15/64	3/64	3/32	CS-13
	27/64			CS-18
	43/64			CS-29
1/4-20	5/16	1/16	1/8	CS-14
	7/16			CS-19
	13/16			CS-30
	1- 1/16			CS-31
1/4-28	7/16	1/16	7/8	CS-20
5/16-18	19/32	3/32	3/16	CS-21
	27/32			CS-32
	1- 3/32			CS-33
3/8-16	19/32	3/32	3/16	CS-22
	27/32			CS-34
	1- 3/32			CS-35
1/2-13	3/4	1/8	1/4	CS-23
	1- 1/8			CS-36

SOCKET HEAD — Class 2A

Screw Size	A	B	C	Part No.
# 2-56	5/32	1/32	1/32	CS-1
# 4-40	5/32	1/32	1/16	CS-2
# 6-32	5/32	1/32	1/16	CS-3
# 8-32	15/64	3/64	3/32	CS-4
#10-24	15/64	3/64	3/32	CS-5
#10-32	15/64	3/64	3/32	CS-6
1/4-20	5/16	1/16	1/8	CS-7

SOCKET HEAD — Class 6G

Dimensions Below Are In Millimeters.

Screw Size	A	B	C	Part No.
M2 x 0.4	3.8	0.8	0.8	MSS2-1
	4.8			MSS2-2
	5.8			MSS2-3
	6.8			MSS2-4
M3 x 0.5	3.8	0.8	1.6	MSS2-5
	4.8			MSS2-6
	5.8			MSS2-7
	6.8			MSS2-8
M4 x 0.7	5.2	1.2	2.4	MSS2-9
	7.2			MSS2-10
	11.2			MSS2-11
	15.2			MSS2-12
M5 x 0.8	7.2	1.2	2.4	MSS2-13
	11.2			MSS2-14
	15.2			MSS2-15
	21.2			MSS2-16
M6 x 1	7.6	1.6	3.2	MSS2-17
	11.6			MSS2-18
	17.6			MSS2-19
	26.6			MSS2-20
M10 x 1.5	14.4	2.4	4.8	MSS2-21
	22.4			MSS2-22
	32.4			MSS2-23

"NO-MAR" KITS

Description of Contents	Number of Parts	Part No.
"No-Mar" Set Screws-Stainless Steel Hex Head. Assorted Sizes from #2-56 to #10-32	100	Y1BK
"No-Mar" Set Screws-Stainless Steel Hex Head. Assorted Sizes from #10-32 to 1/2-13	75	Y19K

METRIC "NO-MAR" KITS

Description of Contents	Number of Parts	Part No.
"No-Mar" Set Screws-Socket, Hexagon Type, stainless steel. Assorted sizes from M2 x 0.4 to M4 x 0.7	100	MAK13
"No-Mar" Set Screws-Socket, Hexagon Type, stainless steel. Assorted sizes from M5 x 0.8 to M10 x 1.5	75	MAK14

SET SCREWS — CUP POINT

Conforming To DIN 916

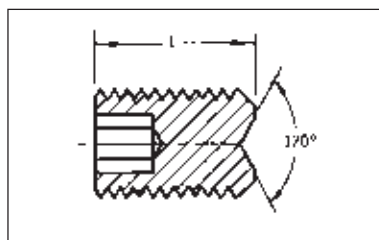

Material: 300 Series Stainless Steel

SOCKET HEAD

Screw Size	L	Part No.
# 0-80	1/8	Y11-1
	3/16	Y11-2
# 2-56	1/8	Y11-3
	3/16	Y11-4
	1/4	Y11-5
# 4-40	5/8	Y11-6
	3/16	Y11-7
	1/4	Y11-8
# 6-32	1/8	Y11-9
	1/4	Y11-10
	3/8	Y11-11
	1/2	Y11-12
	1/4	Y11-13
# 8-32	3/8	Y11-14
	1/2	Y11-15
	5/8	Y11-16
# 10-32	1/4	Y11-17
	1/2	Y11-18
1/4-20	3/4	Y11-19
	1/2	Y11-22
	3/4	Y11-23

SLOTTED HEAD

Screw Size	L	Part No.
#0-80	1/8	C2-15
#2-56	1/8	BE-1-A
#4-40	1/8	BE-2-A
#6-32	1/8	BE-3-A

SOCKET HEAD

Dimensions Below Are In Millimeters

Screw Size	L	Part No.
M1.6 x 0.35	3	MSS4-1
	4	MSS4-2
	5	MSS4-3
M2 x 0.4	3	MSS4-4
	4	MSS4-5
	5	MSS4-6
M2 x 0.5	3	MSS4-7
	4	MSS4-8
	5	MSS4-9
M3 x 0.5	5	MSS4-10
	6	MSS4-11
	6	MSS4-12
M4 x 0.7	4	MSS4-13
	6	MSS4-14
	10	MSS4-15
M4 x 0.7	14	MSS4-16
	6	MSS4-17
	10	MSS4-18
M5 x 0.8	14	MSS4-19
	20	MSS4-20
	6	MSS4-21
M6 x 1	10	MSS4-22
	16	MSS4-23
	25	MSS4-24
M10 x 1.5	12	MSS4-25
	20	MSS4-26
	30	MSS4-26

SET SCREWS-CUP POINT NUTS

Description of Contents	Number of Parts	Part No.
Cup Point Set Screws-Stainless Steel, Hex Head Assorted Sizes from #2-56 to 1/4-20	200	Y234

METRIC SET SCREWS-CUP POINT NUTS

Description of Contents	Number of Parts	Part No.
Socket Set Screws-Hexagon Type Cup Point stainless steel Assorted Sizes from M1.6 x 0.35 to M10 x 1.5	200	MAK18

BRASS TIP SET SCREWS

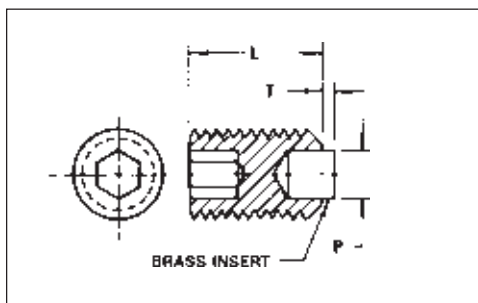

Material: Heat treated alloy steel with brass insert
Finish: Black Oxide

Screw Size	L	P	T	Part Number
2-56	1/8	1/32	1/32	CS-85
	1/4			CS-86
4-40	1/8	1/16	1/32	CS-87
	1/4			CS-88
	3/8			CS-89
6-32	1/8	1/16	1/32	CS-90
	1/4			CS-91
	1/2			CS-92
8-32	1/8	3/32	3/64	CS-93
	1/4			CS-94
	3/8			CS-95
	1/2			CS-96
10-32	1/8	3/32	3/64	CS-97
	3/8			CS-98
	1/2			CS-99

BELLEVILLE SPRING WASHER

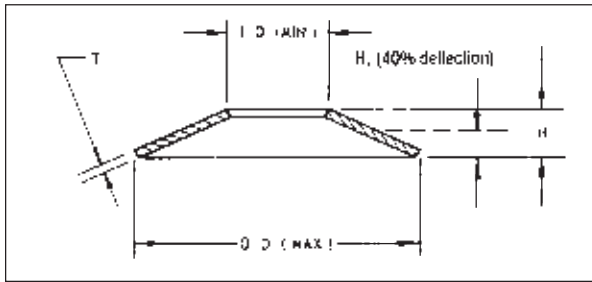

Inside Dia.	Outside Dia.	T	H (Approx.)	H ₁ (Approx.)	*P ₁ ± 10%	Calculated Load at Flat Position—Lbs.	Part No.
.093	.187	.010	.015	.013	14	25	D6-20
.125	.250	.0133	.020	.017	23	43	D6-21
.156	.312	.0166	.025	.021	37	67	D6-22
.190	.375	.020	.030	.025	54	99	D6-23
.255	.500	.025	.038	.031	85	144	D6-24
.317	.625	.032	.048	.040	130	234	D6-25
.380	.750	.040	.059	.049	211	373	D6-26
.505	1.000	.050	.075	.062	306	540	D6-27

*LOAD AT H.

**Material: 300 Series Stainless Steel
Spring Steel**

STACKED BELLEVILLE SPRING WASHERS

Deflection in a single Belleville Spring Washer is small. Series stacking increases the deflection in proportion to the number of washers, but the load remains the same as a single washer. Parallel stacking increases the load approximately proportional to the number of washers (a 5% to 10% load loss per washer is introduced).

ADVANTAGES:

- Stainless Steel non-corrosive
- High loads in small space.
- Combine washers (series or parallel) to vary load carrying possibilities.

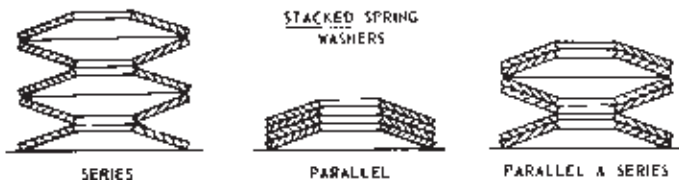

BELLEVILLE SPRING WASHER KITS

Description of Contents	Number of Parts	Part No.
Belleville Spring Washers—Stainless Steel. Eight Sizes from .093 to .505 Inside Diameters.	150	Y13K

METRIC BELLEVILLE SPRING WASHER

All Dimensions In Millimeters

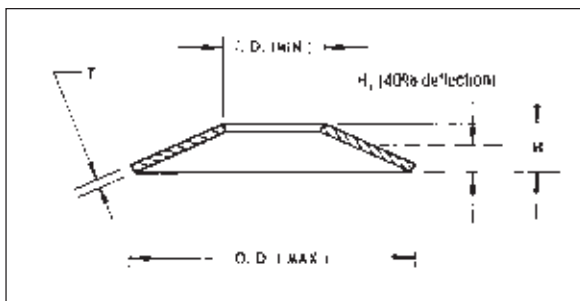

Inside Dia.	Outside Dia.	T	H (Approx.)	H ₁ (Approx.)	*P ₁ ± 10%	Load at Flat Position Newtons	Part No.
3.2	8	0.3	0.55	0.45	66	126	MBW1-1
4.2	8	0.4	0.60	0.52	120	257	MBW1-2
6.2	12.5	0.7	1.00	0.88	369	846	MBW1-3
8.2	18	0.8	1.30	1.10	465	977	MBW1-4
10.2	20	1.1	1.55	1.37	846	1957	MBW1-5
12.2	25	1.5	2.05	1.83	1615	3786	MBW1-6

*LOAD AT H.

**Material: Carbon Spring Steel,
Optional Bright Zinc Finish**

METRIC BELLEVILLE SPRING WASHER KITS

Description of Contents	Number of Parts	Part No.
Belleville Spring Washers, carbon spring steel, plated. Six sizes from 3.2 to 12.2 inside diameters.	120	MAK11

PRECISION WASHERS

Machined

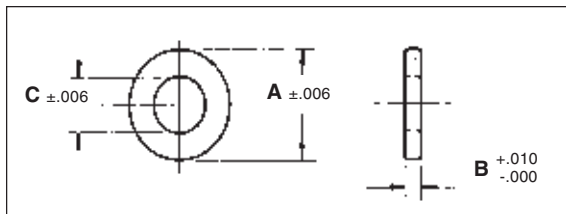

Material: 300 Series Stainless Steel

Screw Size (Ref.)	A	B	C	Part No.
# 4	1/4	1/16	.116	3150
# 6	5/16		.144	3151
# 8	3/8		.169	3152
#10	7/16	5/64	.196	3153
1/4	1/2		.257	3154
5/16	5/8	3/32	.323	3155
3/8	3/4		.386	3156

CURVED WASHERS

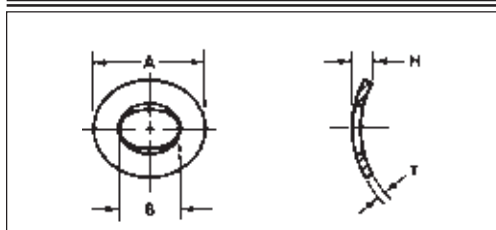

Material: 300 Series Stainless Steel
Spring Tempered

A	B	T	H (Approx.)	Hole Size	Screw Size	Part No.
.245	.135	.006	.034	1/4	# 5	D33-1
.270	.148	.007	.035	9/32	# 6	D33-2
.322	.174	.0075	.042	11/32	# 8	D33-3
.370	.200	.009	.047	3/8	#10	D33-4
.490	.265	.011	.063	1/2	1/4	D33-6
.612	.327	.013	.077	5/8	5/16	D33-7

CAPTIVE SCREWS

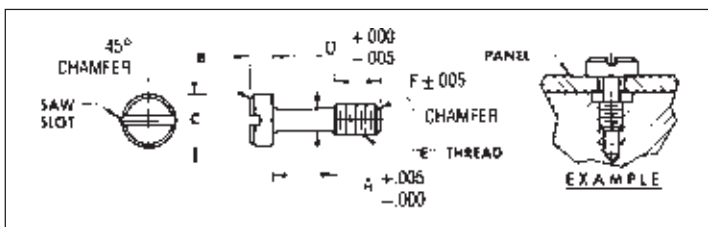

Material: 300 Series Stainless Steel

For Panel Thickness	A	B	C	D	E	F	Part No.
1/16	.281	1/8	1/4	.072	# 4-40	.187	Y9-1
1/8	.343						Y9-2
1/16	.312	1/8	9/32	.086	# 6-32	.218	Y9-3
1/8	.375						Y9-4
3/16	.437						Y9-5
1/8	.406	5/32	5/16	.114	# 8-32	.250	Y9-6
3/16	.468						Y9-7
1/4	.531	3/16	3/8	.136	#10-32	.312	Y9-8
3/16	.531						Y9-9
1/4	.593						Y9-10

METRIC CAPTIVE SCREWS

All Dimensions In Millimeters

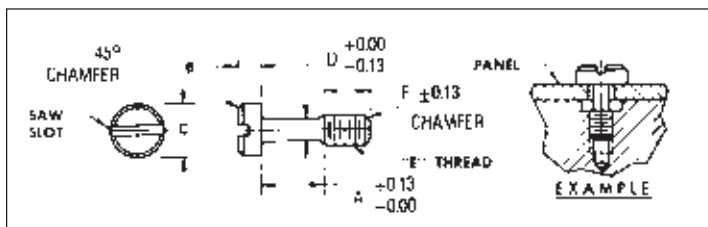

Material: 300 Series Stainless Steel

For Panel Thickness	A	B	C	D	E	F	Part No.
1.5	6.75	2	5.2	2.14	M3	4.50	MCS1-1
3	8.25						MCS1-2
3	9.75	2.8	7	2.69	M4	6.00	MCS1-3
5	11.75						MCS1-4
6	12.75						MCS1-5
5	13.25	3.5	9	3.77	M5	7.50	MCS1-6
6	14.25						MCS1-7

RETAINING RINGS

Internal, External, External-E Ring, Bowed Series

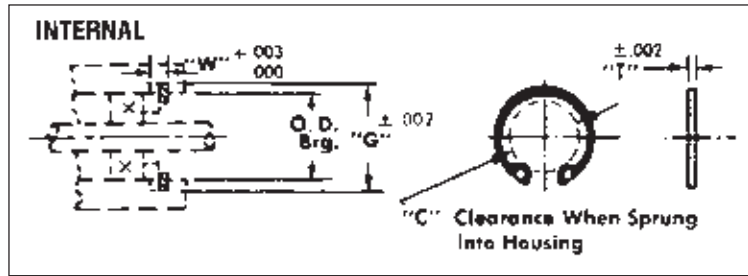

Material: PH 15-7 MO Stainless Steel

Maximum Shaft Dia. (Ref.)	Groove Dims.			C	O.D. Brg.	Part No.
	G	W	T			
.156	.397	.029	.025	.20	.375	Z1-1
.187	.530	.039	.035	.26	.500	Z1-2
.250	.665	.039	.035	.34	.625	Z1-3
.375	.931	.046	.042	.54	.875	Z1-5

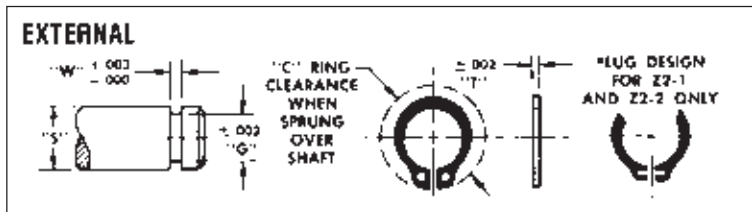

Material: PH 15-7 MO Stainless Steel
*Beryllium Copper

Shaft Dia. (Ref.)	Groove Dims.			C	Part No.
	G	W	T		
.125	.117	.012	.010	.22	Z2-1
.187	.175	.018	.015	.30	Z2-2
.250	.230	.029	.025	.45	Z2-3
.375	.352	.029	.025	.61	Z2-5
.500	.468	.039	.035	.77	Z2-6

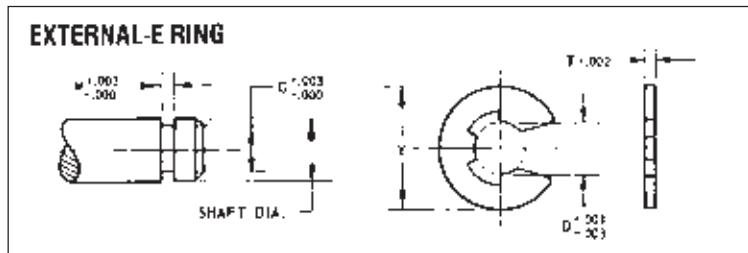

Material: PH 15-7 MO Stainless Steel

Shaft Dia.	Groove Dims.		Y	D	T	Part No.
	G	W				
.093	.074	.018	.187	.073	.015	Z3-7
.125	.095	.018	.230	.094	.015	Z3-1
.156	.116	.029	.282	.114	.025	Z3-6
.187	.147	.029	.335	.145	.025	Z3-2
.250	.210	.029	.527	.207	.025	Z3-3
.312	.250	.029	.500	.243	.025	Z3-4
.375	.303	.039	.660	.300	.035	Z3-5
.500	.396	.046	.800	.392	.042	Z3-6

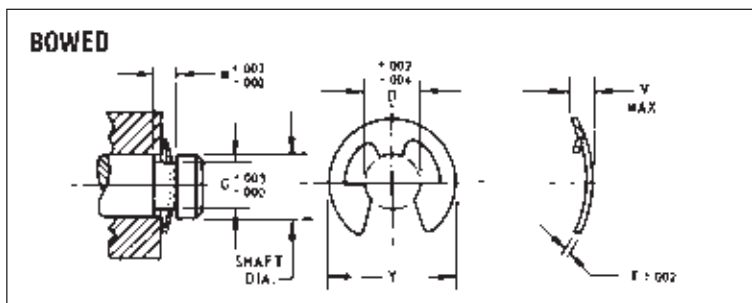

Material: PH 15-7 MO Stainless Steel

Shaft Dia.	Groove Dims.		Y	D	T	V Max.	Part No.
	G	W					
.125	.095	.022	.230	.094	.010	.033	Z4-1
.187	.147	.030	.335	.145	.015	.043	Z4-2
.250	.210	.049	.527	.207	.025	.067	Z4-3
.312	.250	.047	.500	.243	.025	.065	Z4-4
.375	.303	.060	.660	.300	.035	.076	Z4-5
.500	.395	.073	.800	.392	.042	.093	Z4-6

RETAINING RINGS KIT

Description of Contents	Number of Parts	Part No.
Retaining Rings-Stainless Steel Bearing Shaft and Snap Types for shaft sizes 1/16" to 1/4"	400	Y9K

METRIC RETAINING RINGS

All Dimensions In Millimeters ■ Internal, External, External-E Ring Series

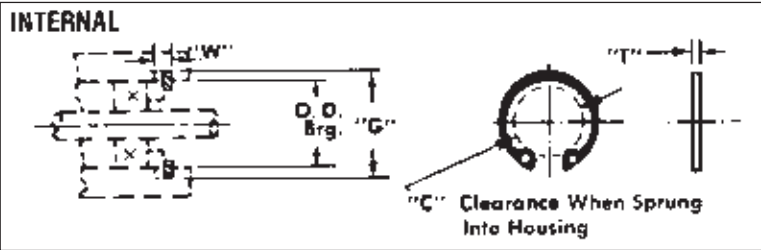

Material: Spring Steel

O.D. BRG.	Groove Dims.			T	C	Part No.
	G	tol	W (min.)			
10	10.4	+0.11	1.1	1.0	4.0	MRR1-2
11	11.4	+0.11	1.1	1.0	4.8	MRR1-3
13	13.6	+0.11	1.1	1.0	6.4	MRR1-4
15	15.7	+0.11	1.1	1.0	8.3	MRR1-5
16	16.8	+0.11	1.1	1.0	9.2	MRR1-6
19	20.0	+0.15	1.1	1.0	11.8	MRR1-7
22	23.0	+0.15	1.1	1.0	14.6	MRR1-8
26	27.2	+0.21	1.3	1.2	17.8	MRR1-9

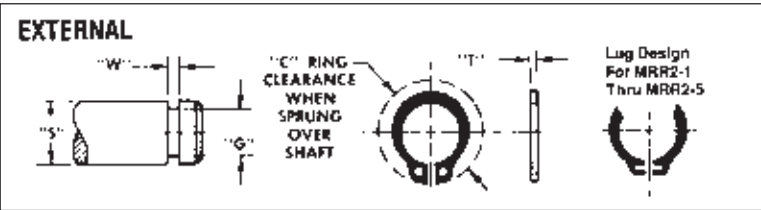

Material: Spring Steel

Shaft Dia. (S)	Groove Dims.			T	C	Part No.
	G	tol	W (min.)			
4	3.8	-0.04	0.5	0.4	8.2	MRR2-2
5	4.8	-0.04	0.7	0.6	9.8	MRR2-3
6	5.7	-0.04	0.8	0.7	11.1	MRR2-4
8	7.6	-0.06	0.9	0.8	14.0	MRR2-5
10	9.6	-0.11	1.1	1.0	16.2	MRR2-6
12	11.5	-0.11	1.1	1.0	18.1	MRR2-7

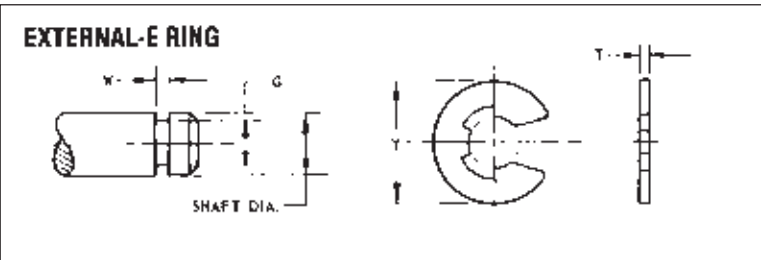

Material: Spring Steel

Shaft Dia.	Groove Dims.			Y (Fitted)	T (max.)	Part No.
	G	tol	W (min.)			
2	1.2	-0.06	0.34	3.0	0.32	MRR3-1
3	1.9	-0.06	0.54	4.5	0.52	MRR3-2
4	2.3	0.06	0.64	6.0	0.62	MRR3-3
5	3.2	-0.07	0.64	7.0	0.62	MRR3-4
6	4.0	-0.07	0.74	9.0	0.72	MRR3-5
8	5.0	-0.07	0.74	11.0	0.72	MRR3-6
10	7.0	-0.09	0.94	14.0	0.92	MRR3-7
12	8.0	-0.09	1.05	16.0	1.03	MRR3-8

METRIC RETAINING RINGS KIT

Description of Contents	Number of Parts	Part No.
Retaining Rings, spring steel, zinc plated. Bearing, shaft and snap type for shaft sizes 3 to 5mm.	400	MAK8

RETAINING RINGS

Gripping External Series

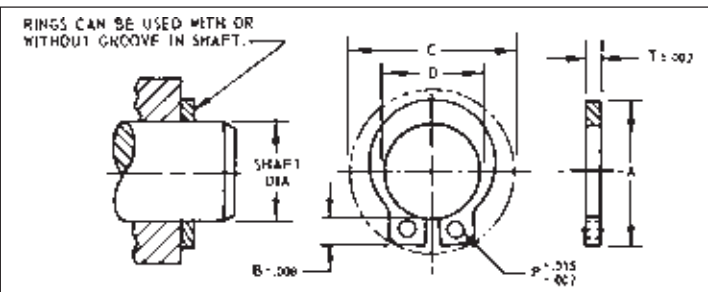

Material: PH 15-7 MO Stainless Steel

Shaft Dia.	A (Ref.)	B	C	D	T	P Dia.	Part No.
.125	.268	.078	.33	.120	.025	.042	Z5-1
.187	.364	.097	.44	.181	.035	.051	Z5-2
.250	.437	.097	.49	.238	.035	.051	Z5-3
.375	.620	.141	.74	.354	.042	.078	Z5-4
.500	.768	.158	.90	.470	.050	.078	Z5-5

MOTOR MOUNT CLEATS

Instant Nulling (Zeroing), Quick Releasing, Self Locking

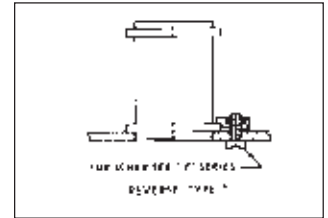
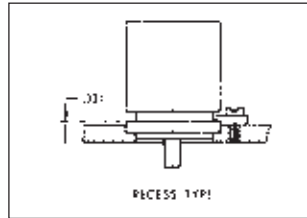
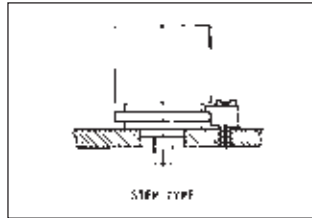
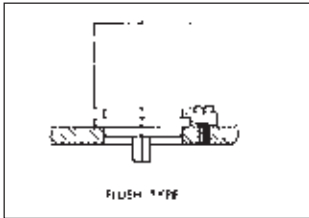

TO DETERMINE BOLT CIRCLE FOR CLEAT LOCATIONS	
FOR CLEAT NO.	USE THE LARGER OF 2 TEST BOLT CIRCLES
13-1-12; 13-10-31*	ADD 270 (.2 + E) TO MAX. HANG-UP DIA. OR ADD 400 TO MAX. DIA. OF BASE OF GROOVE
13-20-24	ADD 195 (.2 + E) TO MAX. HANG-UP DIA. OR ADD 275 TO MAX. DIA. OF BASE OF GROOVE

SPECIFICATIONS

MATERIAL

Clamp: Sintered stainless steel Type 316; tensile strength 60,000 psi; shear strength 25,000 psi.

Screw: Slotted pan head CRES per MS-35233 and MS-35234.

Insert: Nylon (Polyamide) Type 1 per ASTM D 4066. Natural color.

FINISH

Screw: Treated per MIL-S-5002

Clamp: As cast and tumbled

Operating Temperature Range: -55°C to +177°C.

Vibration: 5 to 2000 cps at 15 g acceleration with size 15 synchro.

Shock: 2000 ft. lb. shock, size 15 synchro per MIL-S-901.

Meets all requirements of MIL-E-5272C and MIL-S-901.

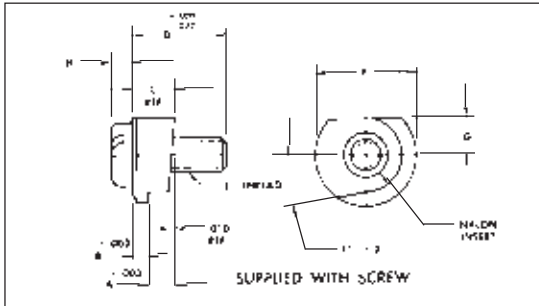
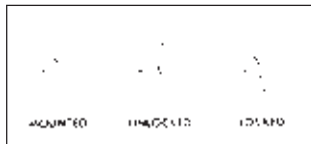
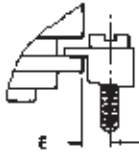

Type Mount	A	B	C	D	E	F	G	H	J	Part No.
Flush & Recess	.031	.040	.071	.312						L3-1
Flush	.062	.040	.102	.312						L3-2
Flush	.062	.060	.112	.375						L3-3
Flush	.062	.063	.125	.375						L3-4
Flush	.093	.040	.133	.375	135	390	125	.068 Max	#4-40	L3-8
Flush	.093	.050	.143	.375		385				L3-7
Flush	.093	.063	.156	.375						L3-8
Step	.125	.050	.175	.375						L3-9
Step	.156	.040	.196	.375						L3-10
Step	.225	.063	.288	.437						L3-11
Flush	.250	.063	.317	.525						L3-12
Flush & Recess	.031	.040	.071	.250						L3-20
Flush	.062	.040	.102	.250	068	285	091	.053 Max	#2-56	L3-22
Flush	.093	.040	.133	.312		260				L3-23
Step	.125	.040	.165	.312						L3-24
Reverse	.062	.063	.125		135	390	125			L3-30*
Reverse	.093	.063	.156			385				L3-31*

*Supplied Less Screw

MOTOR MOUNT CLEATS

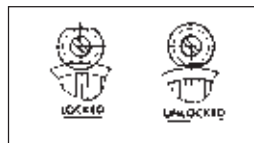
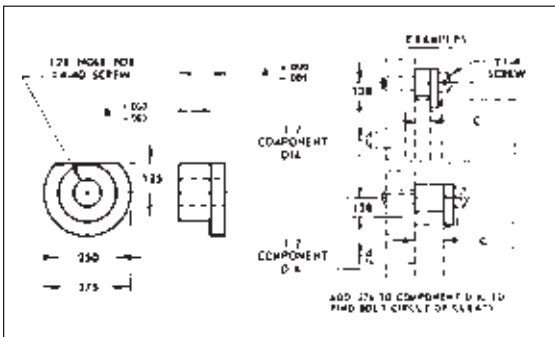

A	B	Order Screw Separately	C	Part No.
300 Series Stainless Steel				
100	.052	Y1-4-I	.062	L2-1
131	.081	Y1-4-J	.093	L2-2
160	.09	Y1-4-J	.125	L2-3
288	.238	Y1-4-W	.250	L2-4
113	.063	Y1-4-J	.072	L2-5
162	.112	Y1-4-J	.125	L2-6
193	.143	Y1-4-V	.155	L2-7
263	.213	Y1-4-W	.225	L2-8
400 Series Stainless Steel				
100	.052	Y1-4-T	.062	L2-11
131	.081	Y1-4-J	.093	L2-12
160	.09	Y1-4-J	.125	L2-13
162	.112	Y1-4-J	.125	L2-16
193	.143	Y1-4-V	.155	L2-17
283	.213	Y1-4-W	.225	L2-18

PRECISION SYNCHRO MOUNTING CLAMPS

Table of Pitch Diameters

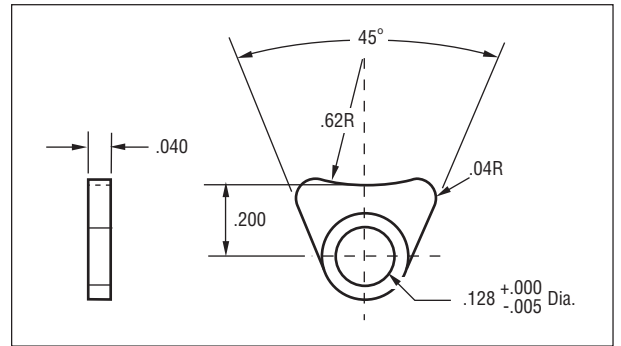
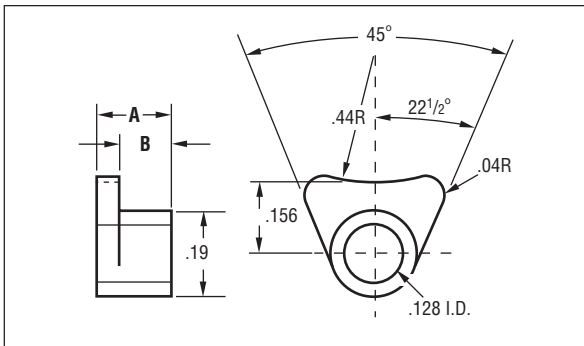

Material: 303 Stainless Steel
Aluminum — Anodized

Material: 302 Stainless Steel
Aluminum — Anodized

A ± .005	B ± .000 -.005	Part Number	
		Stainless Steel	Aluminum
.093	.047	L2-30	L2-33
.156	.110	L2-31	L2-34
.272	.210	L2-32	L2-35

A ± .005	Part Number	
	Stainless Steel	Aluminum
.040	L2-36	L2-37

PRECISION SPACER POSTS

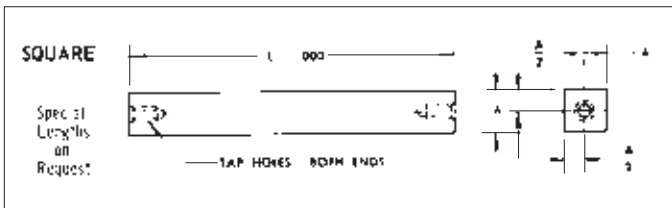

Material: 2024-T4 Aluminum Anodized

A = 1/4" Square Stock			A = 5/16" Square Stock			A = 3/8" Square Stock		
L	Tap Hole	Part No.	L	Tap Hole	Part No.	L	Tap Hole	Part No.
1	#6-32 UNC-2B 1/4" Deep	F1-1	3/4	#6-32 UNC-2B 1/4" Deep	F3-10	1-1/2	#8-32 UNC-2B 5/16" Deep	F2-1
1-1/2		F1-2	1		F3-11	2		F2-2
2		F1-3	1-1/4		F3-12	2-1/2		F2-3
2-1/2		F1-4	1-1/2		F3-13	3		F2-4
3		F1-5	1-3/4		F3-14	3-1/2		F2-5
3-1/2		F1-6	2		F3-15	4		F2-6
4		F1-7	2-1/2		F3-16	4-1/2		F2-7
4-1/2		F1-8	3		F3-17	5		F2-8
5		F1-9	3-1/2		F3-18	5-1/2		F2-9

STAND-OFF THREADED TYPE

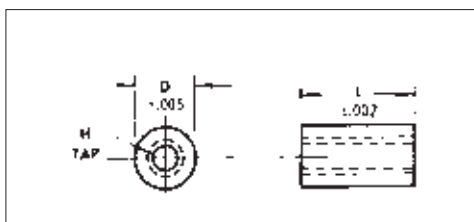

Material: 303 Stainless Steel

Minimum Thread Depth 3/8" from Each End.

H Tap	D	L	Part No.
#4-40	3/16	.250	EG-1
		.375	EG-2
		.500	EG-3
		.750	EG-13
#6-32	1/4	.375	EG-5
		.500	EG-6
#8-32	3/8	.375	EG-9
		.500	EG-10
		.625	EG-11
		.750	EG-12
		1.000	EG-15

PRECISION DOWEL PINS — SLIP FIT

1/32, 1/16, 5/64, 3/32, 1/8, 5/32, 3/16, 1/4, 5/16, 3/8 and 1/2 Inch Diameters

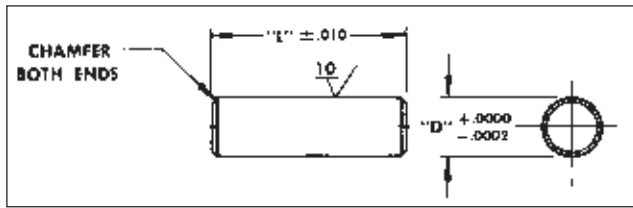

Material: 303 Stainless Steel

L	1/8 Dia. Pin D = .1251	5/32 Dia. Pin D = .1562	3/16 Dia. Pin D = .1875
	Part No.	Part No.	Part No.
1/8	D5-125	—	—
5/32	D5-156	—	—
3/16	D5-187	D8-187	—
7/32	D5-218	—	—
1/4	D5-250	D8-250	D9-250
5/16	D5-312	D8-312	D9-312
3/8	D5-375	D8-375	D9-375
7/16	D5-437	D8-437	D9-437
1/2	D5-500	D8-500	D9-500
5/8	D5-625	D8-625	D9-625
3/4	D5-750	—	D9-750
7/8	D5-875	—	D9-875
1	D5-1000	—	D9-1000
1-1/8	D5-1125	—	—

L	1/32 Dia. Pin D = .0313	1/16 Dia. Pin D = .0626	5/64 Dia. Pin D = .0781	3/32 Dia. Pin D = .0938
	Part No.	Part No.	Part No.	Part No.
3/32	D2-093	D3-093	—	D4-093
1/8	D2-125	D3-125	—	D4-125
5/32	D2-156	D3-156	D7-156	D4-156
3/16	D2-187	D3-187	D7-187	D4-187
7/32	D2-218	D3-218	—	D4-218
1/4	D2-250	D3-250	D7-250	D4-250
5/16	D2-312	D3-312	D7-312	D4-312
3/8	D2-375	D3-375	D7-375	D4-375
7/16	D2-437	D3-437	—	D4-437
1/2	D2-500	D3-500	—	D4-500
5/8	D2-625	D3-625	—	D4-625
3/4	D2-750	D3-750	—	D4-750
7/8	D2-875	D3-875	—	D4-875
1	D2-1000	D3-1000	—	D4-1000

L	1/4 Dia. Pin D = .2500	5/16 Dia. Pin D = .3125	3/8 Dia. Pin D = .3750	1/2 Dia. Pin D = .5000
	Part No.	Part No.	Part No.	Part No.
3/8	D11-375	—	—	—
7/16	D11-437	—	—	—
1/2	D11-500	D12-500	—	—
9/16	D11-562	—	D13-562	—
5/8	D11-625	—	D13-625	—
3/4	D11-750	D12-750	D13-750	D14-750
7/8	D11-875	—	D13-875	—
1	D11-1000	D12-1000	D13-1000	D14-1000
1-1/4	D11-1250	D12-1250	D13-1250	—
1-1/2	D11-1500	—	D13-1500	—

PRECISION DOWEL PINS — INTERFERENCE FIT

1/32, 1/16, 5/64, 3/32, 1/8, 5/32, 3/16, 1/4, 5/16, 3/8 and 1/2 Inch Diameters

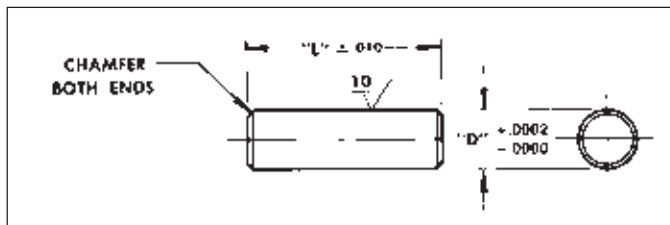

Material: 303 Stainless Steel

L	1/8 Dia. Pin D = .1251	5/32 Dia. Pin D = .1562	3/16 Dia. Pin D = .1875
	Part No.	Part No.	Part No.
1/8	D44-125	—	—
5/32	D44-156	—	—
3/16	D44-187	D45-187	—
7/32	D44-218	—	—
1/4	D44-250	D45-250	D46-250
5/16	D44-312	D45-312	D46-312
3/8	D44-375	D45-375	D46-375
7/16	D44-437	D45-437	D46-437
1/2	D44-500	D45-500	D46-500
5/8	D44-625	D45-625	D46-625
3/4	D44-750	—	D46-750
7/8	D44-875	—	D46-875
1	D44-1000	—	D46-1000
1-1/8	D44-1125	—	—

L	1/32 Dia. Pin D = .0313	1/16 Dia. Pin D = .0626	5/64 Dia. Pin D = .0781	3/32 Dia. Pin D = .0938
	Part No.	Part No.	Part No.	Part No.
3/32	D40-093	D41-093	—	D43-093
1/8	D40-125	D41-125	—	D43-125
5/32	D40-156	D41-156	D42-156	D43-156
3/16	D40-187	D41-187	D42-187	D43-187
7/32	D40-218	D41-218	—	D43-218
1/4	D40-250	D41-250	D42-250	D43-250
5/16	D40-312	D41-312	D42-312	D43-312
3/8	D40-375	D41-375	D42-375	D43-375
7/16	D40-437	D41-437	—	D43-437
1/2	D40-500	D41-500	—	D43-500
5/8	D40-625	D41-625	—	D43-625
3/4	D40-750	D41-750	—	D43-750
7/8	D40-875	D41-875	—	D43-875
1	D40-1000	D41-1000	—	D43-1000

L	1/4 Dia. Pin D = .2500	5/16 Dia. Pin D = .3125	3/8 Dia. Pin D = .3750	1/2 Dia. Pin D = .5000
	Part No.	Part No.	Part No.	Part No.
3/8	D47-375	—	—	—
7/16	D47-437	—	—	—
1/2	D47-500	D48-500	—	—
9/16	D47-562	—	D49-562	—
5/8	D47-625	—	—	—
3/4	D47-750	D48-750	D49-750	D50-750
7/8	D47-875	—	—	—
1	D47-1000	D48-1000	D49-1000	D50-1000
1-1/4	D47-1250	D48-1250	D49-1250	—
1-1/2	—	—	D49-1500	—

METRIC PRECISION DOWEL PINS — PRESS FIT

All Dimensions In Millimeters

1, 1.5, 2, 2.5, 3, 4, 5, 6, 8, 10, 12 mm Diameters

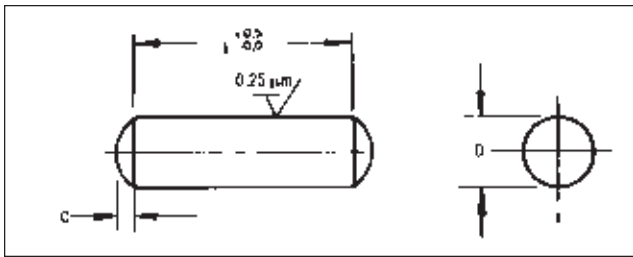

Material: 303 Series Stainless Steel

L	D=1 C=0.15	D=1.5 C=0.23	D=2 C=0.3	D=2.5 C=0.4
	Part No.	Part No.	Part No.	Part No.
3	MDP1-1	—	—	—
4	MDP1-2	MDP2-2	MDP3-2	MDP4-2
5	MDP1-3	MDP2-3	MDP3-3	MDP4-3
6	MDP1-4	MDP2-4	MDP3-4	MDP4-4
8	MDP1-5	MDP2-5	MDP3-5	MDP4-5
10	MDP1-6	MDP2-6	MDP3-6	MDP4-6
12	MDP1-7	MDP2-7	MDP3-7	MDP4-7
14	—	MDP2-8	MDP3-8	MDP4-8
16	—	MDP2-9	MDP3-9	MDP4-9
18	—	—	MDP3-10	MDP4-10
20	—	—	MDP3-11	MDP4-11
24	—	—	—	MDP4-12

L	D=3 C=0.45	D=4 C=0.5	D=5 C=0.75	D=6 C=0.9	L	D=8 C=1.2	D=10 C=1.5	D=12 C=1.8
	Part No.	Part No.	Part No.	Part No.		Part No.	Part No.	Part No.
4	MDP5-1	—	—	—	17	MDP9-2	—	—
5	MDP5-2	MDP6-2	MDP7-2	—	14	MDP9-3	MDP10-3	—
6	MDP5-3	MDP6-3	MDP7-3	MDP8-3	16	MDP9-4	MDP10-4	—
6	MDP5-4	MDP6-4	MDP7-4	MDP8-4	18	MDP9-5	MDP10-5	MDP11-5
10	MDP5-5	MDP6-5	MDP7-5	MDP8-5	20	MDP9-6	MDP10-6	MDP11-6
12	MDP5-6	MDP6-6	MDP7-6	MDP8-6	24	MDP9-7	MDP10-7	MDP11-7
14	MDP5-7	MDP6-7	MDP7-7	MDP8-7	28	MDP9-8	MDP10-8	MDP11-8
16	MDP5-8	MDP6-8	MDP7-8	MDP8-8	32	MDP9-9	MDP10-9	MDP11-9
18	MDP5-9	MDP6-9	MDP7-9	MDP8-9	36	—	MDP10-10	MDP11-10
20	MDP5-10	MDP6-10	MDP7-10	MDP8-10	40	—	MDP10-11	MDP11-11
24	MDP5-11	MDP6-11	MDP7-11	MDP8-11	50	—	—	MDP11-12
28	MDP5-12	MDP6-12	MDP7-12	MDP8-12				

METRIC HARDENED DOWEL PINS — PRESS FIT

All Dimensions In Millimeters

2, 2.5, 3, 4, 5, 6, 8, 10 mm Diameters

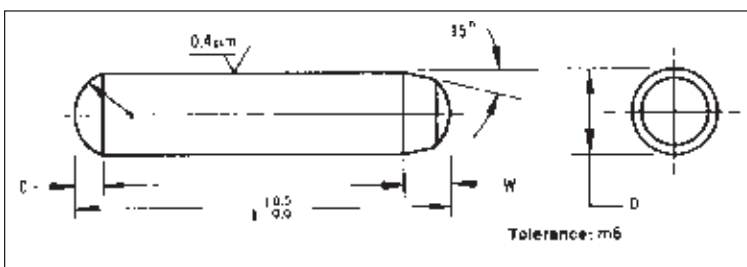

Material: 416 Stainless Steel

Hardened to: 36-42 Rockwell C

L	D=2 W=0.78 C=0.3	D=2.5 W=0.95 C=0.4	D=3 W=1.1 C=0.45	D=4 W=1.4 C=0.6
	Part No.	Part No.	Part No.	Part No.
5	MDP13-1	MDP14-1	—	—
6	MDP13-2	MDP14-2	MDP15-2	—
8	MDP13-3	MDP14-3	MDP15-3	—
10	MDP13-4	MDP14-4	MDP15-4	MDP16-4
12	MDP13-5	MDP14-5	MDP15-5	MDP16-5
14	MDP13-6	MDP14-6	MDP15-6	MDP16-6
16	MDP13-7	MDP14-7	MDP15-7	MDP16-7
20	MDP13-8	MDP14-8	MDP15-8	MDP16-8
24	MDP13-9	MDP14-9	MDP15-9	MDP16-9

L	D=5 W=1.7 C=0.75	D=6 W=2.1 C=0.9	D=8 W=2.6 C=1.2	D=10 W=3.0 C=1.5
	Part No.	Part No.	Part No.	Part No.
10	MDP17-1	—	—	—
12	MDP17-2	MDP18-2	—	—
16	MDP17-3	MDP18-3	MDP19-3	—
20	MDP17-4	MDP18-4	MDP19-4	MDP20-4
24	MDP17-5	MDP18-5	MDP19-5	MDP20-5
30	MDP17-6	MDP18-6	MDP19-6	MDP20-6
40	—	MDP18-7	MDP19-7	MDP20-7

METRIC DOWEL PIN KIT

Description of Contents	Number of Parts	Part No.
Dowel Pins, hardened stainless steel Eight diameters (2 to 10) with assorted lengths (5 to 24)	140	MAK9

DOWEL PINS — HARDENED - PRESS FIT

1/16, 3/32, 1/8, 5/32, 3/16, 1/4, 5/16 and 3/8 Inch Diameters

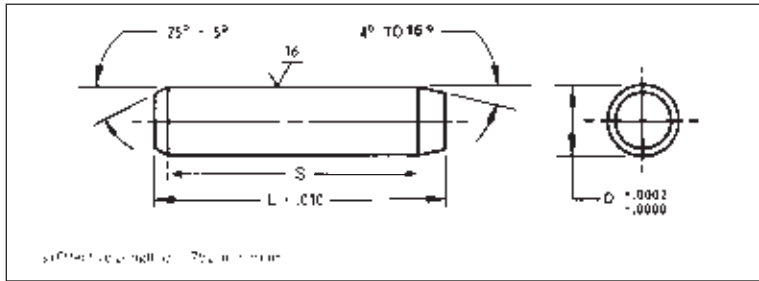

Material: Conforms to specification NASM 16555, 416 Stainless Steel

Finish: Clear Passivate

Hardened To: 36-42 Rockwell C. *Pins not to MS lengths

L	1/16 Dia. Pin D = .0625 Part No.	3/32 Dia. Pin D = .0938 Part No.	1/8 Dia. Pin D = .1251 Part No.	5/32 Dia. Pin D = .1563 Part No.
3/16	D16-187	*D16-187	—	—
1/4	D15-250	*D16-250	*D17-250	—
5/16	D15-312	D16-312	*D17-312	—
3/8	D15-375	D16-375	D17-375	*D18-375
7/16	D16-437	D16-437	D17-437	*D18-437
1/2	D16-500	D16-500	D17-500	D18-500
5/8	D15-825	D16-625	D17-625	D18-625
3/4	D15-750	D16-750	D17-750	D18-750
7/8	*D15-875	D16-875	D17-875	D18-875
1	D15-1000	D16-1000	D17-1000	D18-1000

L	3/16 Dia. Pin D = .1875 Part No.	1/4 Dia. Pin D = .2501 Part No.	5/16 Dia. Pin D = .3126 Part No.	3/8 Dia. Pin D = .3751 Part No.
3/8	*D19-375	—	—	—
1/2	*D19-500	*D20-500	—	—
5/8	D19-625	*D20-625	—	—
3/4	D19-750	D20-750	*D21-750	*D22-750
1	D19-1000	D20-1000	D21-1000	*D22-1000
1-1/4	D19-1250	D20-1250	D21-1250	D22-1250
1-1/2	—	D20-1500	D21-1500	D22-1500

DOWEL PINS KIT

Description of Contents	Number of Parts	Part No.
Dowel Pins - Hardened Stainless Steel Meet MS Spec. Eight Diameters (1/16 to 3/8) with Assorted Lengths (1/4" to 1-1/2")	40	Y106

DOWEL PINS — HARDENED AND GROUND - PRESS FIT

1/16, 3/32, 1/8, 3/16, 1/4, 5/16 and 3/8 Inch Diameters

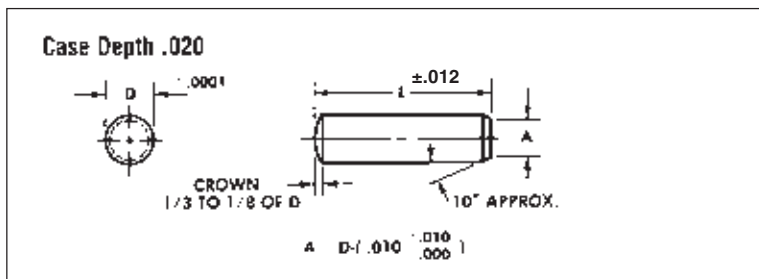

Material: Carbon Steel
Carburized, RC60

L	1/16 Dia. Pin D = .0627 Part No.	3/32 Dia. Pin D = .0940 Part No.	1/8 Dia. Pin D = .1252 Part No.
3/16	D25-187	—	—
1/4	D25-250	D26-250	D27-250
3/8	D25-375	D26-375	D27-375
1/2	D25-500	D26-500	D27-500
5/8	D25-625	D26-625	D27-625
3/4	D25-750	D26-750	D27-750
1	D25-1000	D26-1000	D27-1000
1-1/4	—	—	D27-1250
1-1/2	—	—	D27-1500

L	3/16 Dia. Pin D = .1877 Part No.	1/4 Dia. Pin D = .2502 Part No.	5/16 Dia. Pin D = .3127 Part No.	3/8 Dia. Pin D = .3752 Part No.
1/2	D29-500	D30-500	D31-500	D32-500
3/4	D29-750	D30-750	D31-750	D32-750
1	D29-1000	D30-1000	D31-1000	D32-1000
1-1/4	D29-1250	D30-1250	D31-1250	D32-1250
1-1/2	D29-1500	D30-1500	D31-1500	D32-1500

KNURLED THUMB SCREWS

#4-40 To 1/4-20

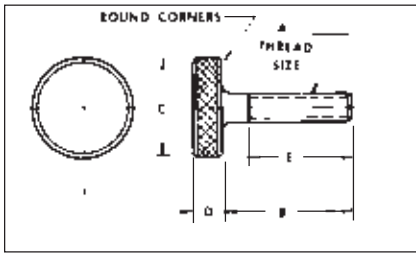

Material: 303 Stainless Steel

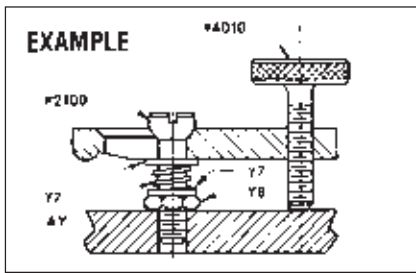
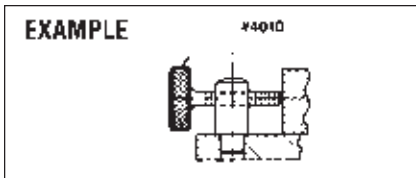

	A	B	C	D	E	Part No.
# 4-40	3/8	1/4	1/8		5/16	4010
	1/2	1/4	1/2		7/16	4011
	3/4	1/4	1/2		5/8	4012
	3/8	3/8	1/8		5/16	4013
	1/2	3/8	1/8		7/16	4014
# 6-32	1/2	1/4	1/2		7/16	4015
	3/4	1/4	1/2		5/8	4016
	1	1/4	1/2		13/16	4017
	3/8	3/8	1/8		5/16	4018
	1/2	3/8	1/8		3/8	4019
# 8-32	1/2	1/4	1/2		7/16	4020
	3/4	1/4	1/2		5/8	4021
	1	1/4	1/2		13/16	4022
	3/8	3/8	1/8		5/16	4023
	1/2	3/8	1/8		3/8	4024
# 10-24	1/2				7/16	4025
	3/4	3/8			5/8	4026
	1				13/16	4027
	3/4			3/16	5/8	4029
	1			3/16	13/16	4030
# 10-24	1 1/4	1/2			1 1/4	4031
	1-1/2				1 1/4	4032
	3/4	3/4			5/8	4033

	A	B	C	D	E	Part No.
#10-32		1/2			7/16	4037
		3/4			5/8	4038
		1	3/8		13/16	4039
		1 1/4			1	4040
		3/4			5/8	4041
		1	1/2	3/16	13/16	4042
		1 1/4			1	4043
		1 1/2			1-1/4	4044
		3/4			5/8	4045
		1	3/4		13/16	4046
1/4-20		1 1/4			1	4047
		1 1/2			1-1/4	4048
		3/4			5/8	4049
		1	3/4		13/16	4050
		1 1/4			1	4051
		1 1/2			1-1/4	4052
		2	3/4	3/16	1-5/8	4053
		3/4			5/8	4054
		1			13/16	4055
		1 1/4	1		1	4056
1/4-20		1 1/2			1 1/4	4057
		2			1-5/8	4058

KNURLED THUMB NUTS

#4-40 To 1/4-20

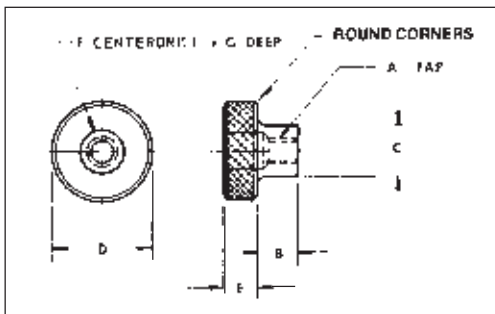

Material: 303 Stainless Steel

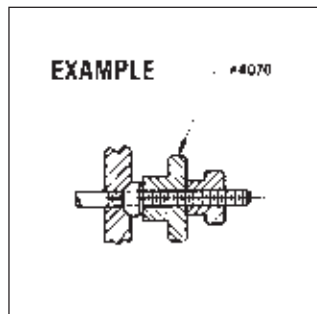

	A	B	C	D	E	F	G	Part No.
# 4-40	1/4	1/4	1/2	1/2	1/8	1/8	1/8	4070
	1/2	1/4	1/2	1/2	1/8	3/8	3/8	4071
# 6-32	1/4		1/2				3/32	4074
	1/2	1/4	1/2	1/8		#26	11/32	4075
	3/4		3/4				3/32	4076
# 8-32	1/4		1/2					4078
	1/2	5/16	1/2	1/8		#15	1/4	4079
	3/4		3/4					4080
# 10-24	1/4		1/2					4082
	1/4	3/8	1	3/16				4084
	1/2		1			13/64	1/4	4085
# 10-32	1/4		1/2					4086
	1/2	3/8	1/2	3/16		13/64	1/4	4087
	3/4		1					4088
	1/2		1			13/64	1/4	4089
1/4-20	1/4		3/4					4090
	1/2		3/4			17/64	1/4	4091
	1/4	1/2	1	1/4				4092
	1/2		1			17/64	1/4	4093
	3/4		1			17/64	1/2	4094

METRIC KNURLED THUMB SCREWS & NUTS

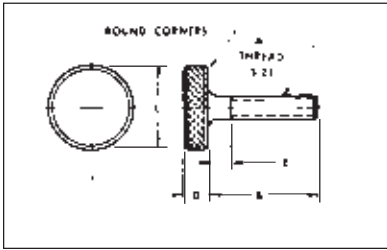

Material: 303 Stainless Steel

	A	B	C	D	E	Part No.
M3 x 0.5		8			0	MTS1-1
		10			0	MTS1-2
		12	12	2.5	2	MTS1-3
		16			2	MTS1-4
M4 x 0.7		10			0	MTS1-5
		12			0	MTS1-6
		16	16	3.5	0	MTS1-7
		20			3	MTS1-8
M5 x 0.8		12			0	MTS1-9
		16			0	MTS1-10
		20	20	4	3	MTS1-11
		25			3	MTS1-12
M6 x 1		30			3	MTS1-13
		16			0	MTS1-14
		20	24	5	4	MTS1-15
		25			4	MTS1-16
	30			4	MTS1-17	

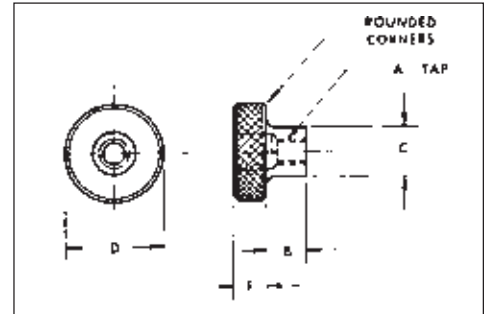

	A	B	C	D	E	Part No.
M3 x 0.5		5	6	12	2.5	MTN1-1
M4 x 0.7		6	8	16	3.5	MTN1-2
M5 x 0.8		7.5	10	20	4	MTN1-3
M6 x 1		10	12	24	5	MTN1-4

SWIVEL STUDS, NUTS & WASHERS

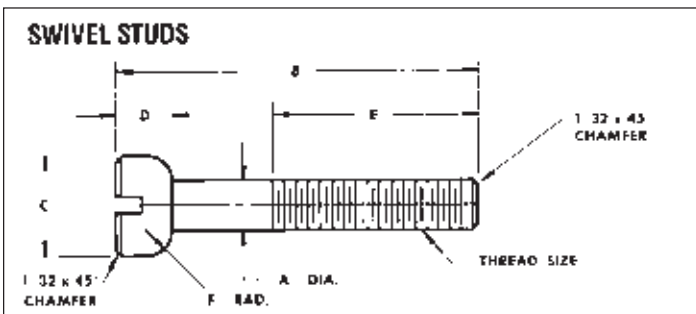

Material: 303 Stainless Steel

Thread Size	A	B	C	D	E	F	Part No.
#10-32	190	1/4	3/8	3/16	5/8	1/8	2100
		1/2			5/8		2101
		3/4			3/4		2102
1/4-20	250	1-1/4	7/16	1/4	7/8	1/8	2103
		1-1/2					2104
		1-3/4					2105
		2					2106

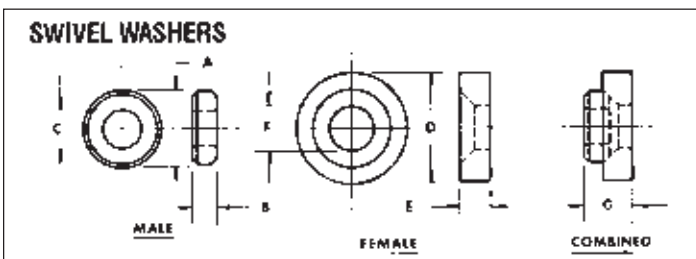

Material: 303 Stainless Steel

Screw Size	Male				Female				Part No.
	A	B	C	Part No.	D	E	F	G	
# 4	9/32		.116	3160			5/32		3170
# 6	9/32	1/8	.144	3161	3/8	1/8	11/64	13/64	3171
# 8	5/16		.169	3162			3/16		3172
#10	3/8	5/32	.196	3163	7/16	1/8	7/32	15/64	3173
1/4	7/16	3/16	.257	3164	1/2	5/32	9/32	17/64	3174
5/16	1/2	3/16	.323	3165	9/16	3/16	11/32	21/64	3175
3/8	5/8	1/4	.386	3166	11/16	1/4	13/32	27/64	3176

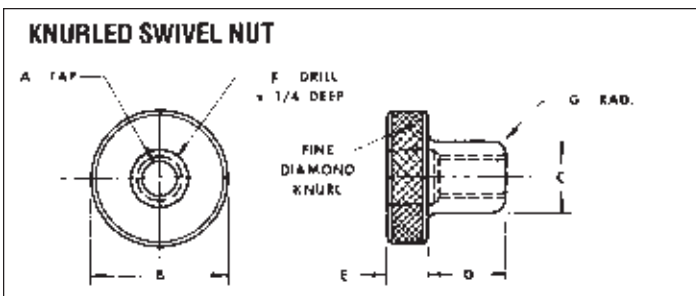

Material: 303 Stainless Steel

	A	B	C	D	E	F	G	Part No.
# 4-40			9/32			1/8		3140
# 6-32		1/2	9/32	1/2	1/8	#26	3/32	3141
# 8-32			5/16			#15		3142
#10-24		3/4	3/8		3/16	13/64		3143
#10-32		3/4	3/8	9/16	3/16	13/64	1/8	3144
1/4-20		1	7/16		1/2	17/64		3145

STAINLESS PRECISION SPRINGS

Compression Extension Anti-Backlash & Experimental Springs

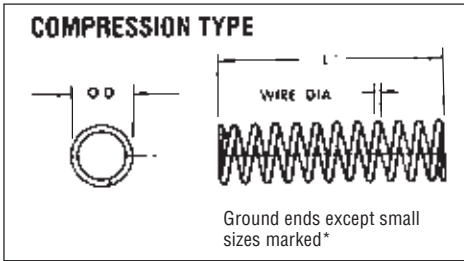

Material: 302 Stainless Steel (Spring Temper)

K = Average spring rate-LB./IN.

O.D.	Wire Dia.	Free Length "L"	K	Aprox. of Coils	Part Number	
1/16	.008	1/4	4.3	20	*AY-20	
	.008	1/2	2	23	*AY-22	
3/32	.010	1/4	4.1	8	*AY-24	
	.010	1/2	1.9	16	*AY-26	
	.010	3/8	5.4	13	*AY-28	
	.010	3/4	2.7	24	*AY-30	
1/8	.016	1/4	14.6	7	AY-32	
	.016	1/2	6.9	12	AY-34	
	.018	3/8	15	10	AY-36	
	.018	3/4	7.1	19	AY-38	
	.020	3/8	23.1	11	AY-40	
	.020	3/4	11	20	AY-42	
	.022	1/2	25.8	14	AY-44	
	.022	1	12.2	27	AY-46	
	3/16	.018	1/2	5.6	7	AY-48
		.018	1	2.7	13	AY-50
.020		1/2	8.1	8	AY-52	
.020		1	3.7	15	AY-54	

O.D.	Wire Dia.	Free Length "L"	K	Aprox. of Coils	Part Number	
3/16	.022	1/2	11.8	8	AY-56	
	.022	1	5.4	16	AY-58	
	.024	1/2	15.8	9	AY-60	
	.024	1	7.5	17	AY-62	
	.026	1/2	22.2	9	AY-64	
	.026	1	10.2	17	AY-66	
	.029	3/4	21.5	14	AY-68	
	.029	1-1/2	10.4	27	AY-70	
	.032	3/4	34.3	14	AY-72	
	.032	1-1/2	15.6	28	AY-74	
	1/4	.026	1/2	14.5	6	AY-76
		.026	1	6.2	11	AY-78
.035		1/2	40.9	7	AY-80	
.035		1	22.50	13	AY-82	

*Ground ends except small sizes marked

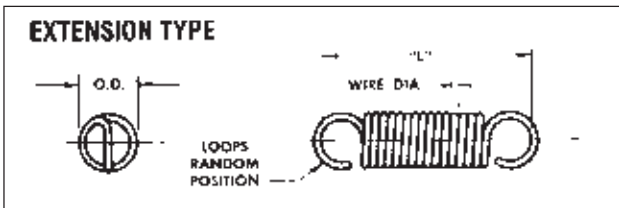

Material: 302 Stainless Steel (Spring Temper)

K = AVERAGE SPRING RATE-LB./IN.

O.D.	Wire Dia.	Free Length "L"	K	Part No.
1/16	.006	1-2	E	AZ-22
3/32	.010	3-4	J	AZ-26
	.010	3-4	K	AZ-28
1/8	.016	1-1-1/2	L	AZ-30
	.020	3-4	M	AZ-32
3/16	.022	3-4	N	AZ-36
	.022	1-1-1/2	O	AZ-38
	.031	3-4	P	AZ-44

O.D.	Wire Dia.	Free Length "L"	K	Part No.
1/4	.026	1-1/4	1.6	AZ-50
	.029	1-1/4	2.8	AZ-54
	.031	3-4	10.0	AZ-56
	.031	1-1/4	4.1	AZ-58
	.034	3-4	14.8	AZ-60
	.034	1-1/4	6.6	AZ-62

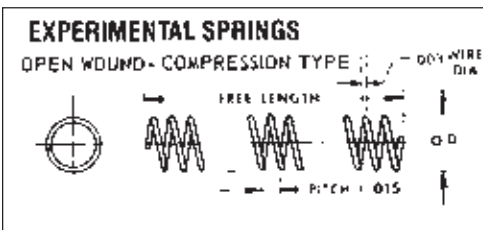

Material: 302 Stainless Steel-Spring Temper

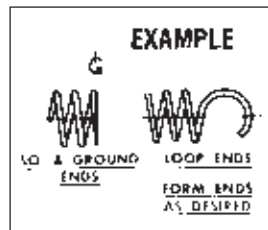

O.D.	Fits Over Pin or Screw Dia.	Wire Dia.	Aprox. No. of Coils	Pitch	Free Length	Part No.
3/32	-	.0159	32	.047	1-1/2	AY-1
1/8	-	.0179	37	.052	2	AY-2
3/16	-	.0226	37	.076	2-1/2	AY-3
1/4	-	.0253	29	.090	3	AY-4
5/16	-	.0320	24	.125	3-1/2	AY-5
3/8	3/32	.0159	17	.042	1	AY-7
11/64	1/8	.0179	19	.062	1-1/4	AY-8
1/4	3/16	.0226	22	.075	1-1/2	AY-9
21/64	1/4	.0253	19	.093	1-3/4	AY-10
25/64	5/16	.0320	16	.125	2	AY-11
15/32	3/8	.0413	12	.156	2-1/4	AY-12
39/64	1/2	.0485	16	.156	2-1/2	AY-13

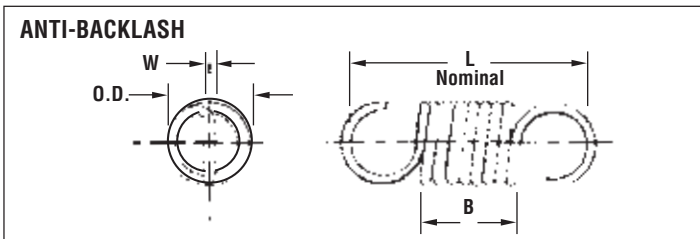

Type Gear	Pitch	W Wire Dia.	L Nominal	O.D. ±.010	K	B Approx.	Part Number
Spur	48 to 120	.012	.350	.115	1.7	.170	BE-16
Worm	48 & 64	.015	.350	.115	5.7	.170	BE-66
Spur	24 & 32	.018	.350	.115	16	.170	BE-67
Mini Spur	Miniature	.012	.240	.093	0.6	.120	BE-16M

STAINLESS PRECISION SPRING KITS

Description of Contents	Number of Parts	Part No.
Compression Springs-Stainless Steel Assorted diameters from .057 to .240 and lengths from 1/4" to 2".	150	Y7K
Extension Springs-Stainless Steel Assorted diameters from .110 to .172 and lengths from 1/4" to 2".	150	Y8K

HANDLES — CHASSIS

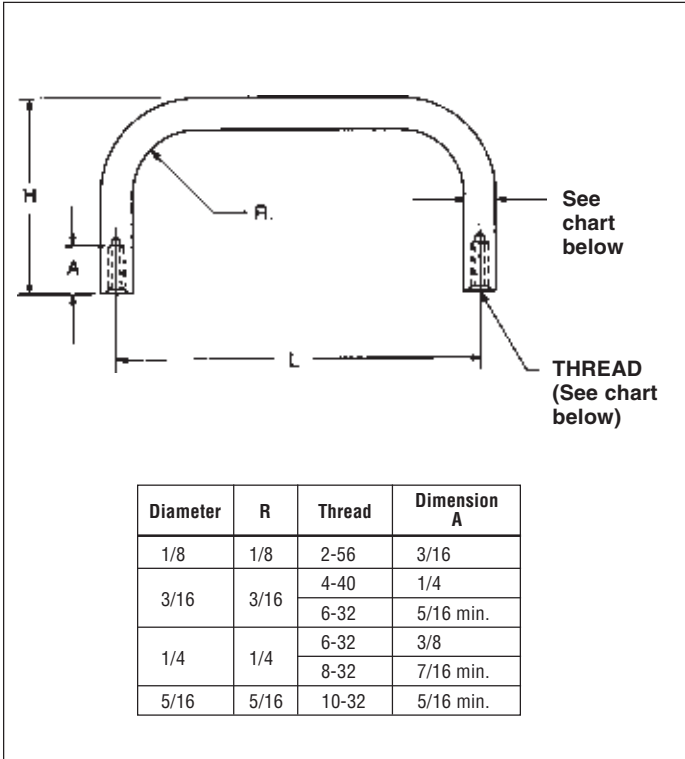

1/8 Round Internal Thread Handle

Center to Center L	Leg Height H	Part Number Prefix	Thread	Material / Finish
3/4"	1/2"	EF000-	for 2-56 add 256 -	for Aluminum Black Anodize add A1 or for Stainless Steel add SS
1"	1/2"	EF003-		
1-1/4"	1/2"	EF004-		
1-1/2"	1/2"	EF005-		
2"	1/2"	EF006-		

Example: 1/8" Round Aluminum, Black Anodize, 1-1/2" length: **EF005-256-A1**

3/16 Round Internal Thread Handle

Center to Center L	Leg Height H	Part Number Prefix	Thread	Material / Finish
1"	3/4"	EF054-	for 4-40 add 440 -	for Aluminum Black Anodize add A1
1-1/4"	3/4"	EF055-		
1-1/2"	3/4"	EF056-		
2"	3/4"	EF058-		
3"	3/4"	EF059-		
4"	3/4"	EF060-	for 6-32 add 632 -	for Aluminum Black Anodize add A1 or for Stainless Steel add SS
1"	3/4"	EF054-		
1-1/4"	3/4"	EF055-		
1-1/2"	3/4"	EF056-		
2"	3/4"	EF058-		
3"	3/4"	EF059-		
4"	3/4"	EF060-		

Example: 3/16" Round Stainless Steel, 3" length, 6-32 thread: **EF059-632-SS**

1/4 Round Internal Thread Handle

Center to Center L	Leg Height H	Part Number Prefix	Thread	Material / Finish
1-1/8"	1"	EF102-	for 6-32 add 632 - or for 8-32 add 832 -	for Aluminum Black Anodize add A1 or for Stainless Steel add SS
1-1/4"	1"	EF103-		
1-1/2"	1"	EF104-		
2"	1"	EF106-		
3"	1"	EF110-		
4"	1"	EF111-		
5"	1"	EF112-		

Example: 1/4" Round Aluminum, Black Anodize, 2" length, 8-32 thread: **EF106-832-A1**

5/16 Round Internal Thread Handle

Center to Center L	Leg Height H	Part Number Prefix	Thread	Material / Finish
2"	1-1/2"	EF172 —	for 10-32 add 1032 -	for Aluminum Black Anodize add A1 or for Stainless Steel add SS
2-1/2"	1-1/2"	EF176 —		
3"	1-1/2"	EF178 —		
3-1/2"	1-1/2"	EF181 —		
4"	1-1/2"	EF182 —		
4-1/2"	1-1/2"	EF184 —		
5"	1-1/2"	EF187 —		
5-1/2"	1-1/2"	EF189 —		
6"	1-1/2"	EF191 —		
6-1/2"	1-1/2"	EF193 —		

Example: 5/16" Round Stainless Steel, 5" length, 10-32 thread: **EF187-1032-SS**

Material: Aluminum, Stainless Steel

Aluminum

Finish: Anodize — Black

HANDLES — CHASSIS

5/8 x 9/32 Oval Internal Thread Handle Aluminum — Black Anodize (10-32 Thread)

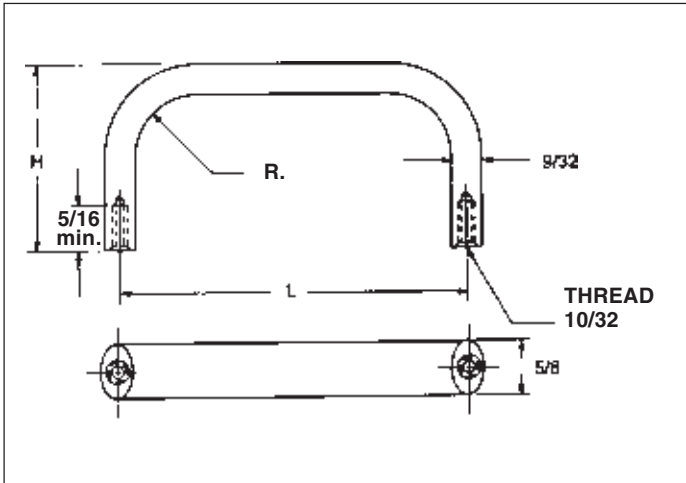

Center to Center L	Leg Height H	Part Number
3"	1"	EF349-1032-A1
4"	1"	EF350-1032-A1
4-9/16"	1"	EF353-1032-A1
3"	1-9/32"	EF358-1032-A1
4"	1-9/32"	EF359-1032-A1
4-1/2"	1-9/32"	EF361-1032-A1
4-9/16"	1-9/32"	EF362-1032-A1
5"	1-9/32"	EF363-1032-A1
6"	1-9/32"	EF364-1032-A1
4"	1-1/2"	EF368-1032-A1
4-1/2"	1-1/2"	EF370-1032-A1
4-9/16"	1-1/2"	EF371-1032-A1
5"	1-1/2"	EF372-1032-A1
6"	1-1/2"	EF373-1032-A1
6-7/16"	1-1/2"	EF374-1032-A1
7"	1-1/2"	EF375-1032-A1
3"	1-3/4"	EF376-1032-A1
4"	1-3/4"	EF377-1032-A1
4-9/16"	1-3/4"	EF380-1032-A1
5"	1-3/4"	EF381-1032-A1
6"	1-3/4"	EF383-1032-A1
6-7/16"	1-3/4"	EF384-1032-A1
7"	1-3/4"	EF385-1032-A1

Material: Aluminum

Aluminum

Finish: Anodize — Black

HANDLES — CHASSIS

Original Style Threaded & Tap Type

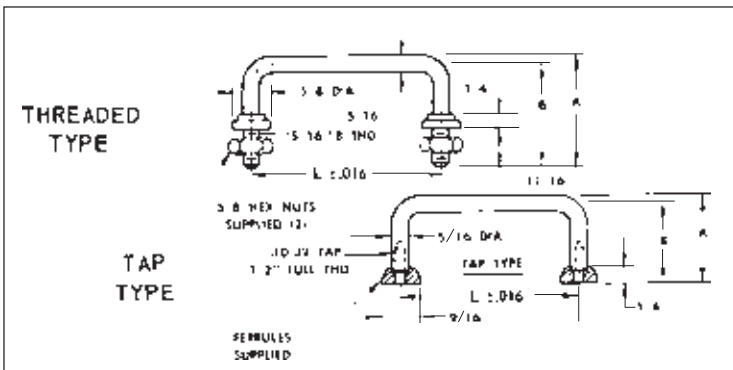

Material: Stainless Steel

L	B	Threaded Type		Tap Type	
		A	Part Number	A	Part Number
3.000	1-1/2	1-21/32	EF-1	1-21/32	EF-5
4.500	1-1/2	1-21/32	EF-2	1-21/32	EF-6
5.500	1-5/8	1-25/32	EF-3	1-25/32	EF-7
6.500	1-3/4	1-29/32	EF-4	1-29/32	EF-8

PRECISION ENGRAVED DISC DIALS

Clockwise & Counter Clockwise

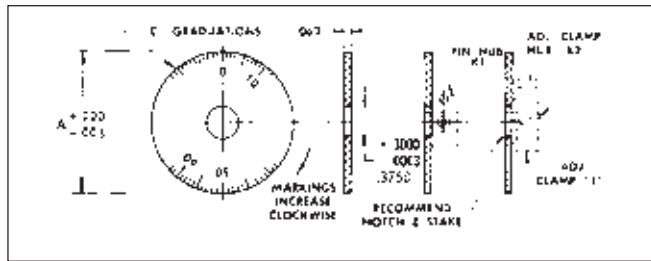

Material: 2024-T4 Aluminum (Black Anodize)

For Dial Hubs See Page 12-67

A	Steps In Degrees	C	Range	Rotation	Part No.
1 500		BLANK	—	Clockwise	MI-1
	2°	180	0-360		*MI-2
	3°36'	100	0-100		MI-3
	6°	60	0-60		MI-4
	7°12'	50	0-50		MI-5
	14°24'	25	0-25		MI-6
	36°	10	0-10		MI-7
2 000		BLANK	—	Clockwise	MI-8
	2°	180	0-360		*MI-9
	3°	120	0-120		MI-9A
	3°36'	100	0-100		MI-10
	5°	72	0-72		MI-10A
	6°	60	0-60		MI-11
	7°12'	50	0-50		MI-12
14°24'	25	0-25	MI-13		
36°	10	0-10	MI-14		
3 000		BLANK	—	Clockwise	MI-15
	1°	360	0-360		MI-15A
	2°	180	0-360		*MI-16
	1°48'	200	0-200		MI-17
	2°	180	0-180		MI-18
	3°	120	0-120		MI-18A
	3°36'	100	0-100		MI-19
5°	72	0-72	MI-19A		
7°12'	50	0-50	MI-20		
36°	10	0-10	MI-21		
4 000		BLANK	—	Clockwise	MI-22
	1°	360	0-360		MI-22A
	2°	180	0-360		*MI-23
	1°48'	200	0-200		MI-24
	2°	180	0-180		MI-25
	3°36'	100	0-100		MI-26
	7°12'	50	0-50		MI-27
36°	10	0-10	MI-28		
3 000	1°	360	0-360	Counter-Clockwise	MI-29
	2°	180	0-360		*MI-30
	3°36'	100	0-100		MI-31
4 000	1°	360	0-360	Counter-Clockwise	MI-32
	2°	180	0-360		*MI-33

Numerals Filled with White *Dial Numbered Every 20°
 Back of disc dials engraved to order. Specify blank dial number with sketch of engraving.

DISC DIALS & VERNIER SETS

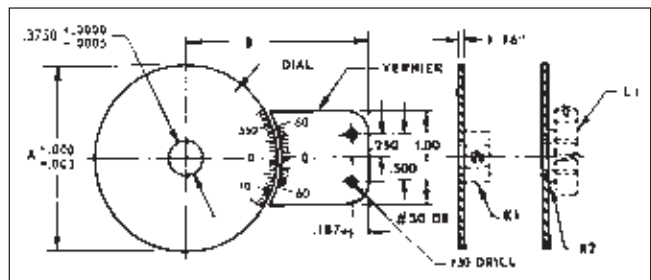

Material: 2024-T4 Aluminum
 Finish: Black Anodize

For Dial Hubs See Page 12-67

A	B	Vernier Reading	Graduations	Range	Disc Dial Only Part No.	Disc Vernier Only Part No.	Set Part No.
1 500	1 760	12'	180 in 2° Steps	0-360°	*AW-1-D	AW-1-V	AW-1
2 000	2 010	12'	160 in 2° Steps	0-360°	*AW-2-D	AW-2-V	AW-2
3 000	2 310	6'	360 in 1° Steps	0-360°	AW-3-D	AW-3-V	AW-3
4 000	3 010	5'	360 in 1° Steps	0-360°	AW-4-D	AW-4-V	AW-4

*Dial Numbered Every 20°

PRECISION ENGRAVED DRUM DIALS

Clockwise & Counter Clockwise

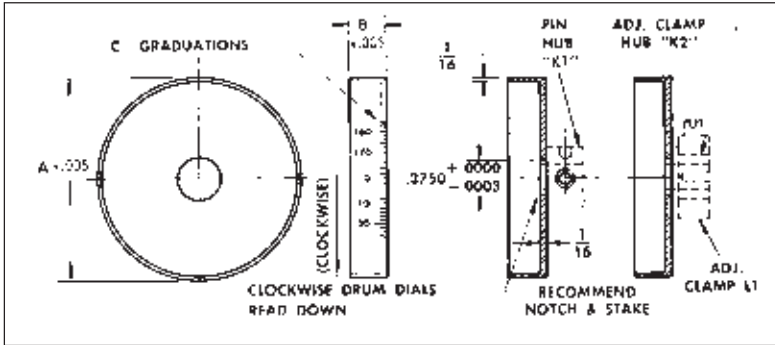

Material: 2024-T4 Aluminum (Black Anodize)

For Dial Hubs See Page 12-67

A	B	Steps in Degrees	C	Range	Rotation	Part No.
990	375	3°36'	BLANK	—	Clockwise	M2-1B
		2°	100	0-100		M2-1
		2°	180	0-360		*M2-19
1490	375	—	BLANK	—	Clockwise	M2-2B
		6°	50	0-60		M2-2
		3°36'	100	0-100		M2-20
		2°	180	0-360		*M2-12
1990	375	7°17'	BLANK	—	Clockwise	M2-3B
		14°24'	50	0-50		M2-3
		36°	10	0-10		M2-4
		2°	180	0-180		M2-5
		2°	180	0-360		M2-13
		2°	180	0-360		*M2-14
2490	500	—	BLANK	—	Clockwise	M2-6B
		2°	200	0-200		M2-6
		2°	180	0-180		M2-15
		2°	180	0-360		*M2-16
		1°	360	0-360		M2-21
2990	500	3°36'	100	0-100	Clockwise	M2-17
		2°	180	0-180		M2-7B
		3°36'	100	0-100		M2-7
		36°	10	0-10		M2-8
		1°	360	0-360		M2-10
2990	500	2°	180	0-360	Counter-Clockwise	M2-22
		2°	180	0-360		*M2-11
2990	500	1°	360	0-360	Counter-Clockwise	M2-23
		2°	180	0-360		*M2-24
2490	500	1°	360	0-360	Counter-Clockwise	M2-25
		2°	180	0-360		*M2-26

*Dial Numbered Every 20°

Special drum dials engraved to order. Specify blank dial number with sketch of engraving.

DRUM DIALS & VERNIER SETS

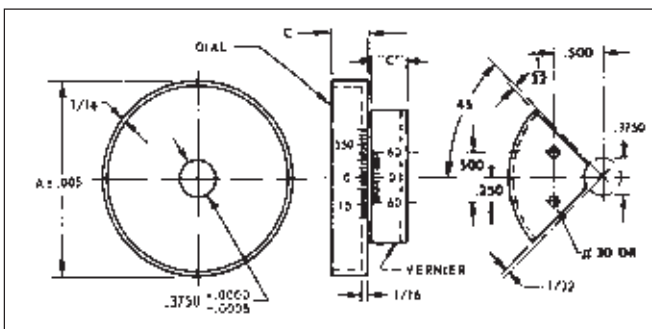

Material: 2024-T4 Aluminum
Finish: Black Anodize

A	C	Vernier Reading	Graduations	Range	Drum Dial Only Part No.	Drum Vernier Only Part No.	Set Part No.
1490	375	12'	180 in 2° Steps	0-360°	*AX-1-D	AX-1-V	AX-1
1990	375	12'	180 in 2° Steps	0-360°	*AX-2-D	AX-2-V	AX-2
2490	500	6'	360 in 1° Steps	0-360°	AX-3-D	AX-3-V	AX-3
2990	500	6'	360 in 1° Steps	0-360°	AX-4-D	AX-4-V	AX-4

*Dial Numbered Every 20°. Matching Vernier Numbered 120-0-120.

DIAL INDEX — DISC & DRUM

Precision Engraved

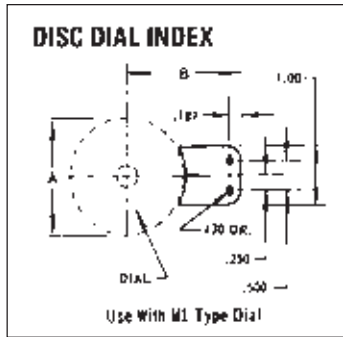

DISC DIAL INDEX

A Dial Dia.	B	Part No.
1.500	1.760	M4-1
2.000	2.010	M4-2
3.000	2.510	M4-3
4.000	3.010	M4-4

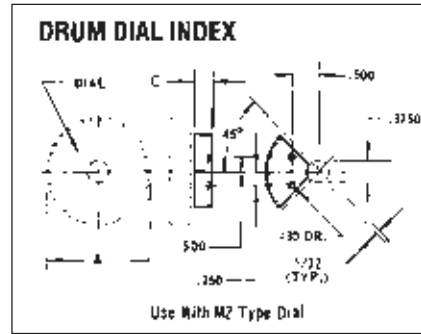

DRUM DIAL INDEX

A Dial Dia.	C	Part No.
1.490	.375	M5-1
1.990	.375	M5-2
2.490	.500	M5-3
2.990	.500	M5-4

Material: 2024-T4 Aluminum
Finish: Black Anodize

ENGRAVED INDEX & DIAL LOCK

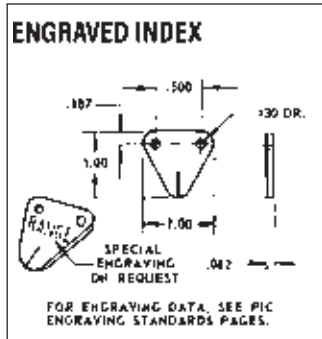

ENGRAVED INDEX

Material	Part No.
Clear Plexiglass	M3-1
2024 T4 Aluminum Black Anodize	M3-2

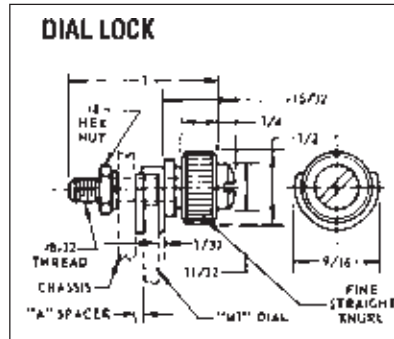

DIAL LOCK

A	Part No.
1/16	M1-50
1/8	M1-51

All Stainless Steel
Mounting Hardware
Is Supplied

DIAL LOCK DESIGNED TO LOCK FLAT DISC
DIALS SPACED "A" DISTANCE FROM PANEL

WOODRUFF KEYS

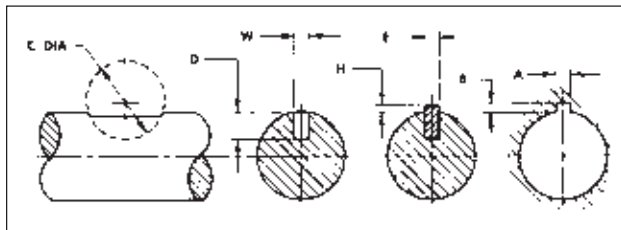

Material: 300 Series Stainless Steel.

A, B, C, D and W are key seat dimensions

Nominal Key	A +.002	B +.005	C +.018	D +.005	W +.0015	H +.010	E +.001	ANSI Key #	Part Number
1/16 x 1/4	.0635	.0372	.250	.0728	.0615	.0262	.0625	202	CR-201
3/32 x 5/16	.0948	.0529	.312	.0882	.0928	.0419	.0938	302.5	CR-207
1/16 x 3/8	.0635	.0372	.375	.1358	.0615	.0262	.0625	203	CR-211
3/32 x 3/8	.0948	.0529	.375	.1202	.0928	.0419	.0938	303	CR-212
1/8 x 3/8	.1260	.0685	.375	.1045	.1240	.0575	.1250	403	CR-213
1/16 x 1/2	.0635	.0372	.500	.1668	.0615	.0262	.0625	204	CR-1
1/8 x 1/2	.1260	.0685	.500	.1355	.1240	.0575	.1250	404	CR-3
1/8 x 5/8	.1260	.0685	.625	.1825	.1240	.0575	.1250	405	CR-5

PRECISION HAND CRANKS

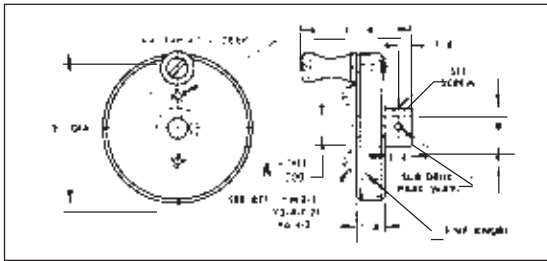

Material: 2024-T4 Aluminum
(Black Anodize)

A	B	Sub Drill	Set Screw	Part No.
.1248	.312	#69	#2-56	W3-1
.1873	.375	#60	#4-40	W3-2
.2498	.500	#50	#6-32	W3-3
.375	.750	—	(2)#8-32	W3-4

KNURLED KNOBS — PIN HUB

.125, .1875, .250 Bores

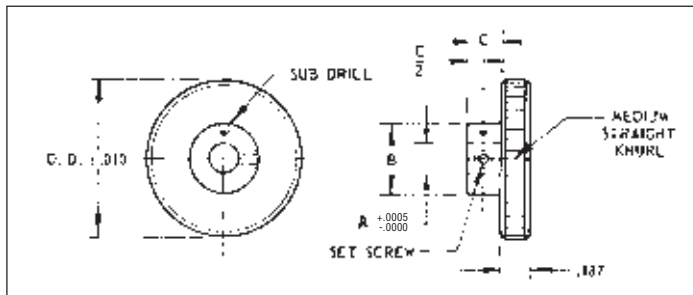

O.D.	A	B	C	Sub Drill	Set Screw	Part No.
1.000	.1248	.312	.187	#69	#2-56	BG-1
1.000	.1873	.375	.218	#60	#4-40	BG-4
1.500	.1873	.375	.218	#60	#4-40	BG-5
1.000	.1873	.375	.218	#60	#4-40	BG-7
1.500	.2498	.500	.250	#50	#5-32	BG-8
2.000	.2498	.500	.250	#50	#5-32	BG-9

Material: 303 Stainless Steel

Note: "A" bore is a thru hole.

BREADBOARD DEVELOPMENT PARTS

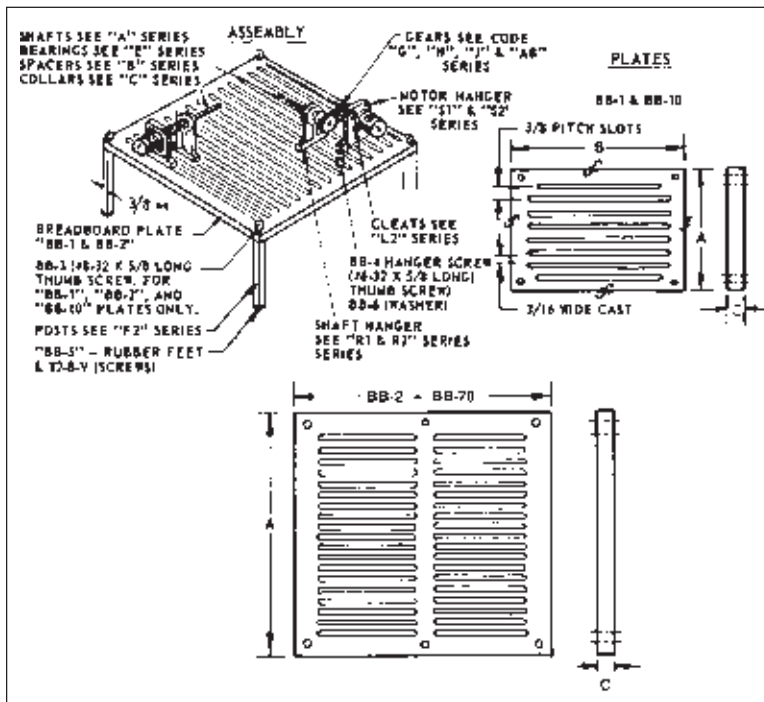

Description	Material	Dimensions	Part No.
Breadboard Plate	Aluminum (Anodized)	A=4", B=8", C=3/8	BB-10
		A=8", B=8", C=3/8	BB-1
		A=8", B=16", C=3/8	BB-2
		A=16", B=16", C=3/8	BB-70
Thumb Screw	Stainless Steel	#8-32 x 5/8 Long	BB-3
		#6-32 x 5/8 Long	BB-4
Washers	Stainless Steel	For #6 Screw	BB-6
Rubber Feet	Black Buna "S"	For F Series Posts	BB-5

MODULAR FRAMING ELEMENTS STRUCTURAL EXTRUSIONS

MOUNTING HARDWARE AND ACCESSORIES

*Now In
 Standard &
 Miniature
 Styles*

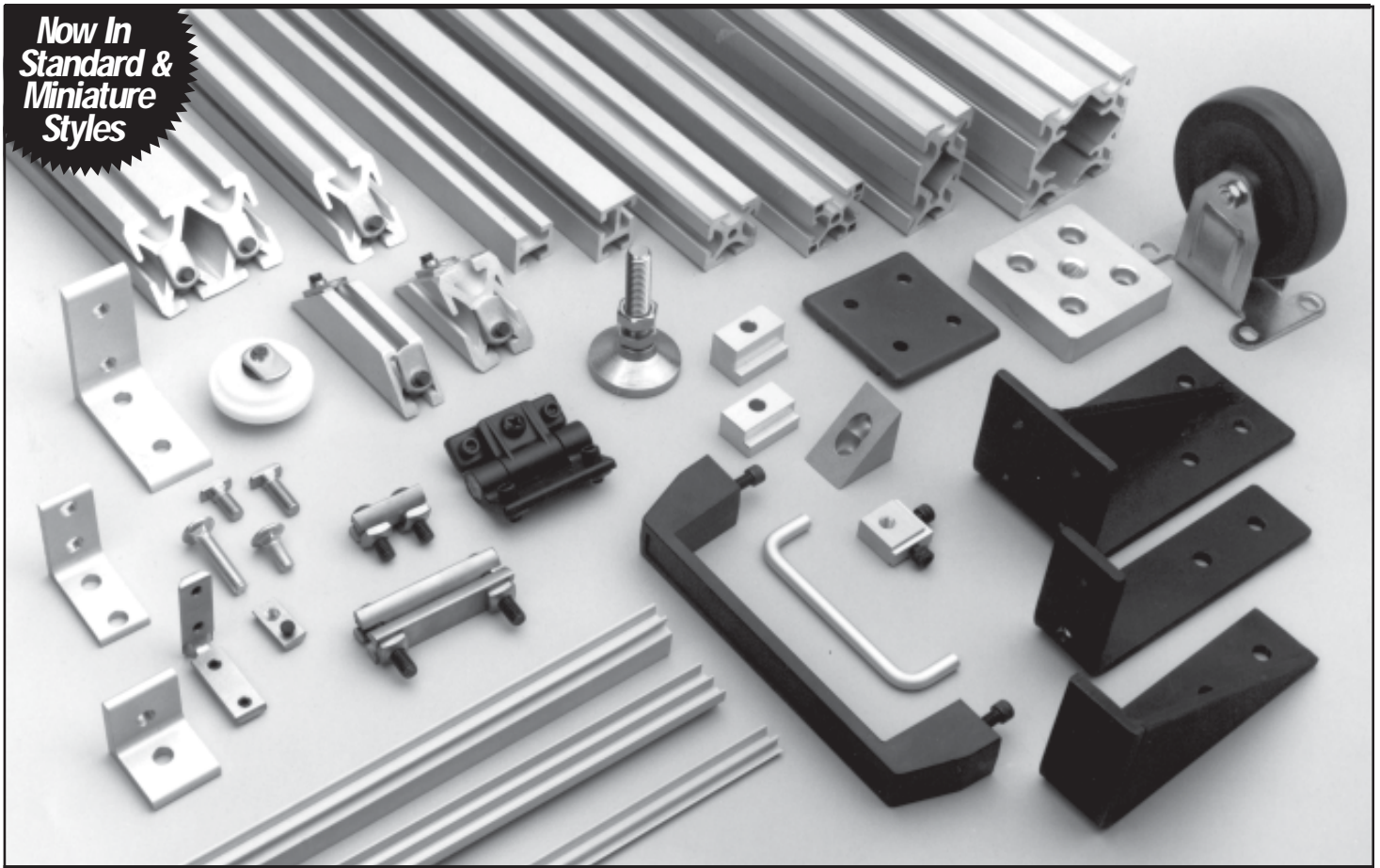

PIC-STIX* modular framing elements offer a simplified approach to structural construction that is becoming State-of-the-Art for industrial and laboratory applications.

The system consists of an assortment of anodized aluminum **PIC-STIX** extrusions in combination with a wide range of joining and fastening elements and accessories.

The **PIC-STIX** system allows you to construct structures of many configurations and sizes. It is easy to assemble various structures without special training or tooling. A few simple hand tools are all that is required.

All joint connections are fastened together to provide flexibility and quick changeover as well as reuse of all elements.

PIC-STIX —

Extrusions with T-Slot grooves are clear anodized for corrosion free finish. The longitudinal slots are utilized for inserting

T-Bolts and nuts anywhere along its length to attach connecting brackets and accessories.

The **PIC-STIX** elements consists of:

- Extrusions: Light and regular extrusions of various constructions
- Mounting Components: Extrusion Corners, various Brackets and Braces
- Fastening Hardware: T-Nuts, Cross and End Connectors, Turn & Lock T-Bolts, T-Bolts, Mounting Screws and Washers
- Accessories: Leveling and Anchoring Plates, Adjustable Legs, Casters, Handles, Hinges, End Plates, Gaskets, and Door Slide Tracks.

Typical applications for modular construction elements:

- Industrial & Laboratory Apparatus
- Machine Support Frames
- Linear Motion Systems
- Work Stations - Benches
- Handling & Robotic Systems
- Tooling & Fixture Supports
- Machine Guarding Structures

Ordering Flexibility

PIC Design makes it easy for you to incorporate **PIC-STIX** in your design. Order any of the following options:

- Order **PIC-STIX** system components so that you can design, cut and assemble in your shop the system you need when you need it.
- Design the system you want including detailed extrusion lengths, provide a bill of material and let PIC provide you with a kit of components ready for assembly in your shop.
- Provide PIC with a detailed print and bill of materials, and have PIC assemble and ship the completed system to you. This option works best when **PIC-STIX** are used as a platform for a PIC Linear Motion System.
- Now also available in miniature size using 1/4"-20 hardware.

TECHNICAL SECTION

Structural Design Guidelines — Standard

Individual profile length and load requirements should not exceed the curve in any load example. If this occurs, choose a profile with a larger section modulus to stay below the curve.

Load Condition:

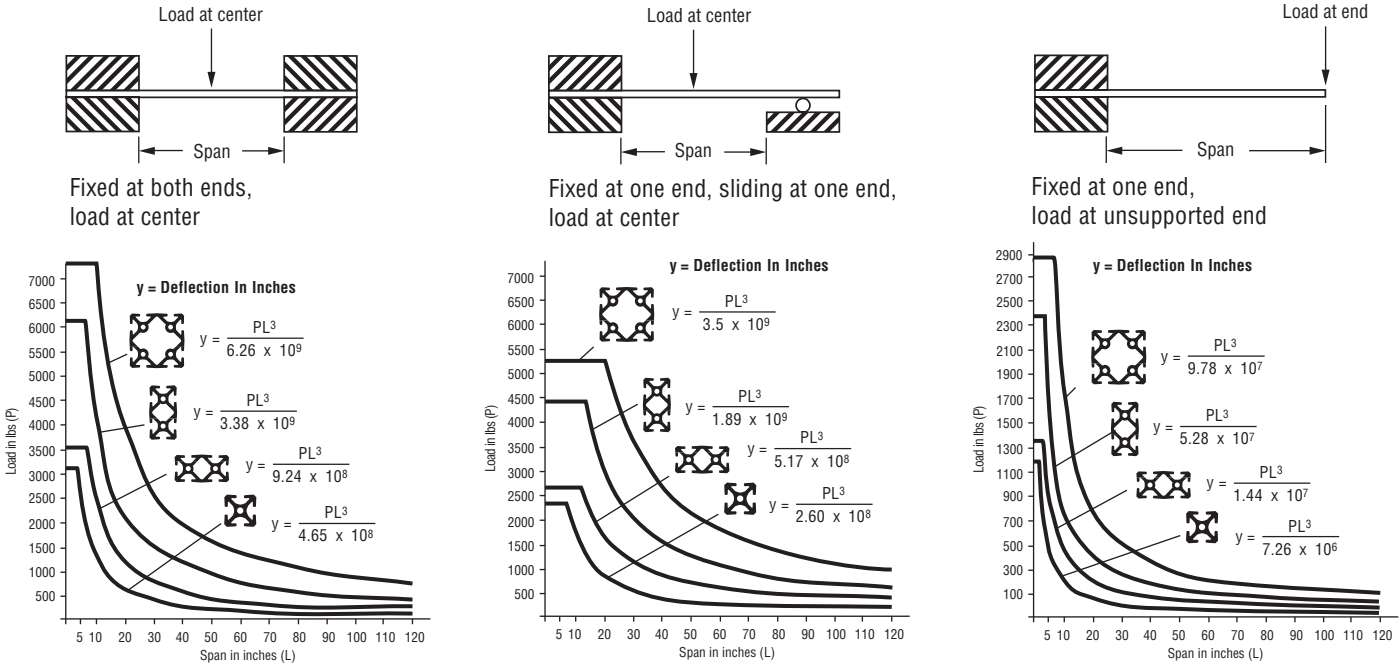

PIC-STIX					
Profile Part Number	SX3030	SX1530	SX1530	SX1515	SX1515L
Moment of Inertia-in ⁴	3.26	.481	1.173	.242	.108
Section Modulus-in ³	2.173	.641	1.76	.323	.136

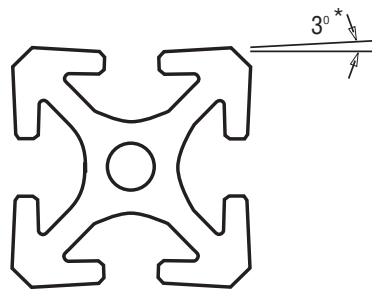

* Angle is 1° on SX1010L, SX1015L, SX1515L, and SX1545L

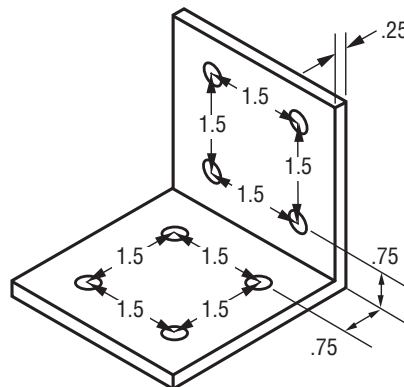

All **PIC-STIX** extrusions have a 1 or 3 degree decline from extrusion edge to slot centerline. When fasteners are properly tightened, the feature serves as a lock mechanism to keep them tight.

Standard mounting and connecting brackets have clearance holes for 5/16" dia. connecting screws which are all on .75" and 1.5" centers.

PIC fastener brackets, extrusions, hardware and accessories provide an unlimited system for structural design and assembly.

Suggested Applications

- **SX1010L** (1" x 1") — Light
Ideal for machine guards, enclosures, and displays.
- **SX1015L** (1" x 1 1/2") — Light
Enclosures, benches.
- **SX1515L** (1 1/2" x 1 1/2") — Light
Light load bearing structures, guarding and lightweight support frames.
- **SX1515** (1 1/2" x 1 1/2") —
Medium load bearing structures, a good combination of structural strength in a compact size.
- **SX1530** (1 1/2" x 3") —
Used for larger and stronger structures and machine frames. The center of this extrusion can be used to run air or electrical lines.
- **SX3030** (3" x 3") —
For larger structures where maximum strength is desired. The center of these extrusions can also be used to run air or electrical lines.

TECHNICAL SECTION

Structural Design Guidelines — [Miniature]

Individual profile length and load requirements should not exceed the curve in any load example. If this occurs, choose a profile with a larger section modulus to stay below the curve.

Load Condition:

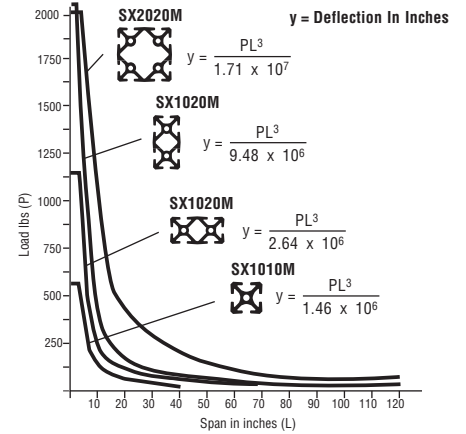
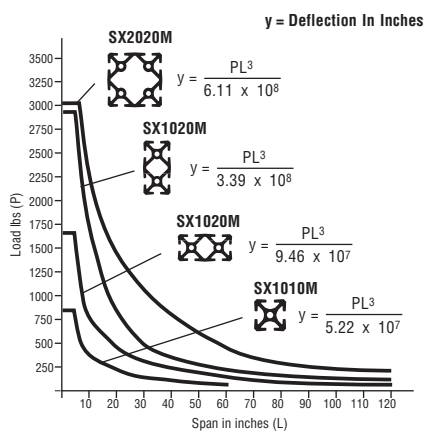
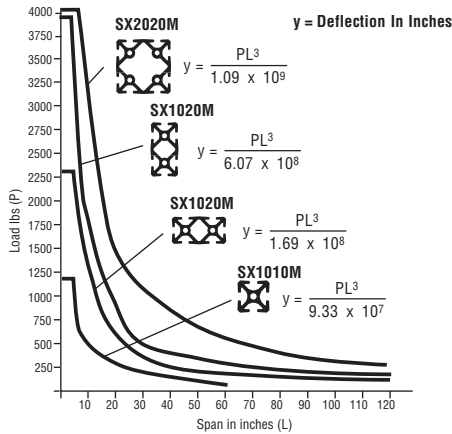
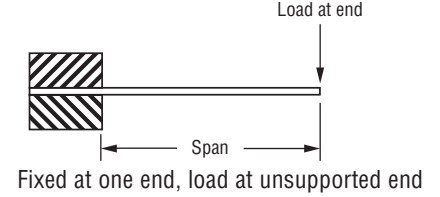
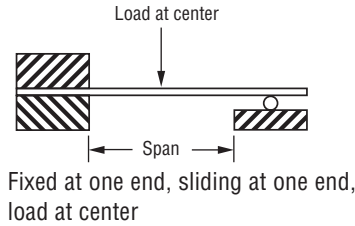
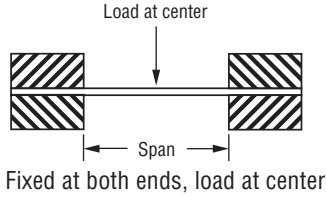

PIC-STIX				
Profile Part Number	SX2020M	SX1020M	SX1020M	SX1010M
Moment of Inertia-in ⁴	.570	.316	.088	.049
Section Modulus-in ³	.570	.316	.176	.097
Est. Area-in ²	1.248	.807		.451
Weight / ft - lbs.	1.468	.949		.530

Material: 6105-T5 Aluminum

Finish: Clear Anodize

Miniature Framing Elements use 1/4-20 Hardware and appropriately noted components

Note: Miniature dimensions and part numbers are in [brackets]

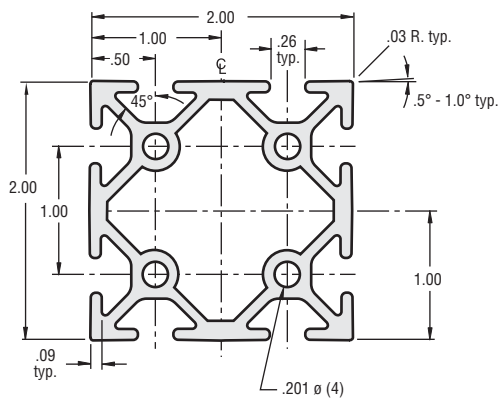

SX2020M

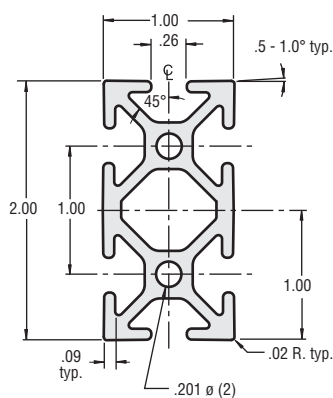

SX1020M

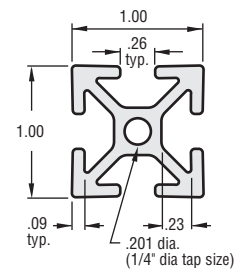

SX1010M

MODULAR FRAMING ELEMENTS

PIC-STIX Structural T-Slot Extrusions

Light Aluminum Extrusions

SX1515L

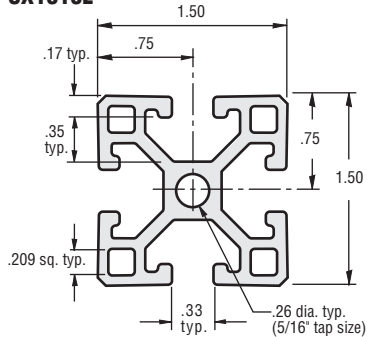

SX1545L

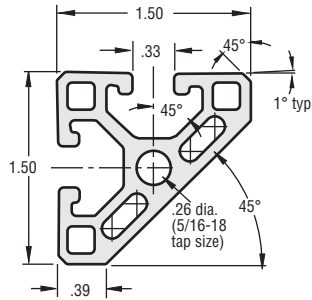

Aluminum Extrusions

SX1515

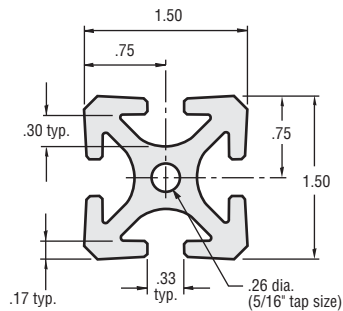

SX1530

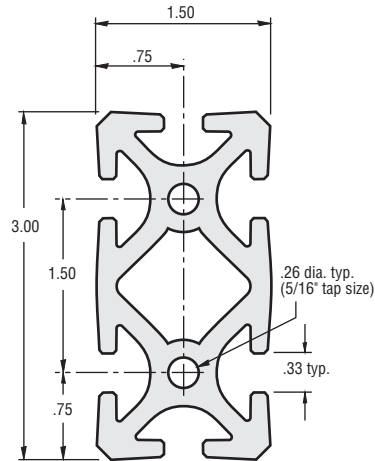

SX3030

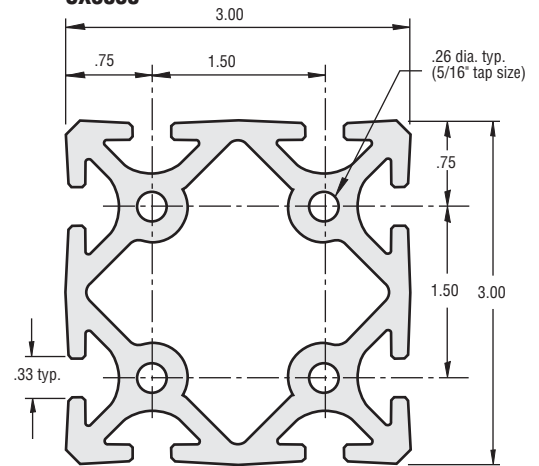

Material: 6105-T5 Aluminum

Finish: Clear Anodize

Modulus Of Elasticity: 11,000,000 PSI

PIC-STIX — T-Slot Extrusions

Basic Size (Inch)	Wall Type	Maximum Length (Inch)	Weight per Foot (lbs.)	Estimated Area (Square Inch)	* Part Number (Length Code)
1.5 x 1.5	Light	144	1.03	.878	SX1515L - □□□□
1.5 x 1.5 corner	Light	144	.86	.729	SX1545L - □□□□
1.5 x 1.5	Standard	144	1.40	1.164	SX1515 - □□□□
1.5 x 3.0	Standard	144	2.48	2.051	SX1530 - □□□□
3.0 x 3.0	Standard	144	3.83	3.188	SX3030 - □□□□
1.0 x 1.0	Miniature	144	.53	.451	SX1010M - □□□□
1.0 x 2.0	Miniature	144	.95	.807	SX1020M - □□□□
2.0 x 2.0	Miniature	144	1.47	1.248	SX2020M - □□□□

- NOTES:**
1. Custom cut lengths on request — contact factory
 2. Pre-drilled access holes, connector holes, tapped end holes available on request — contact factory
 3. Up to 106 inch lengths shipped via UPS; over 106 inch lengths shipped via truck

* Custom lengths may be ordered to .01" increments up to the maximum length. The tolerance on cuts is $\pm 1/32"$. For a precision milled cut with a tolerance of $\pm .005"$, add "P" after length in the part number. All custom lengths will carry an appropriate cut off charge.

MOUNTING COMPONENTS

Connecting Angle Brackets — Standard & [Miniature]

SCB1-10*

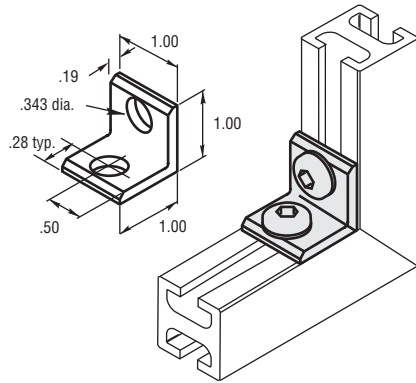

**SCB15-15
[SCBM10-10]**

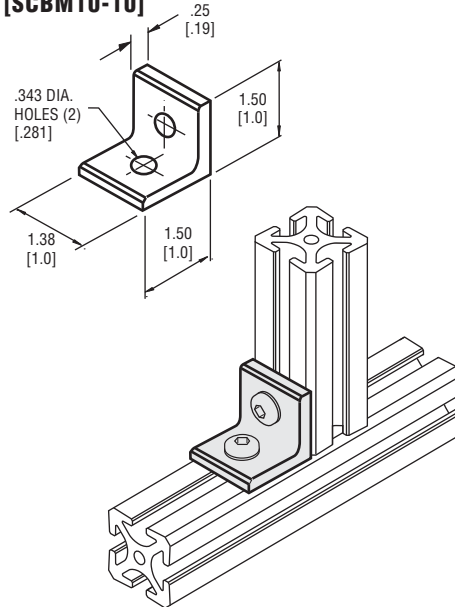

**SCB30-15
[SCBM20-10]**

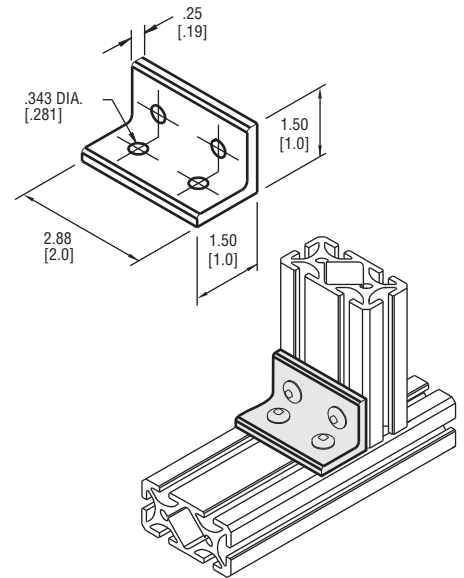

SCB1-20*

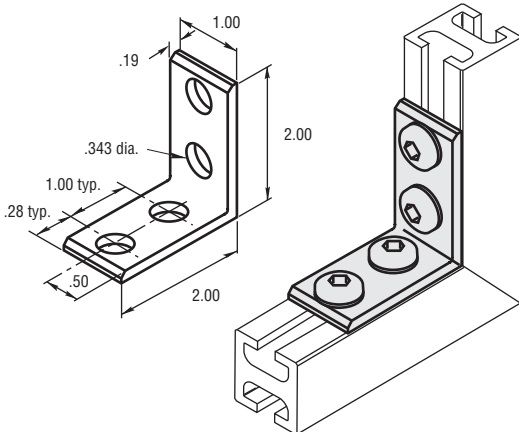

**SCB15-30
[SCBM10-20]**

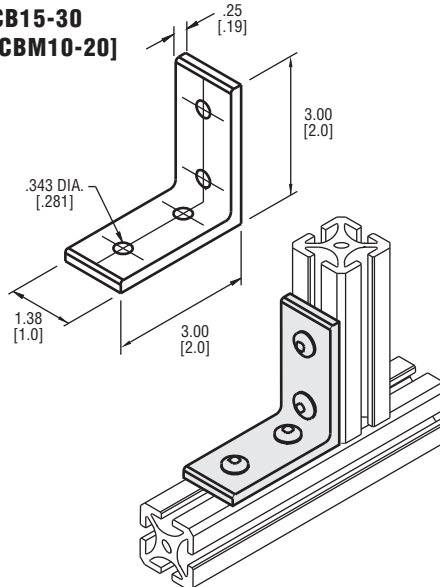

**SCB30-30
[SCBM20-20]**

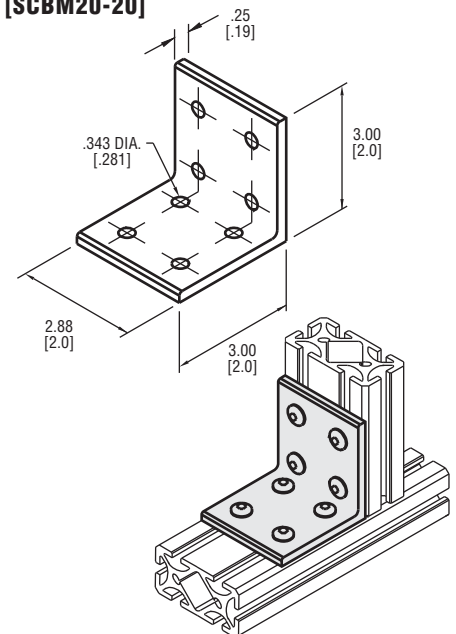

Requires user to select and order separately .63" length button or socket head capscrews and T-Nut from Fastening Hardware section.

*Note: Use .5" length screws.

Inside corner brackets eliminate special machining operations and allow you to construct your framework without counterbores or access holes using only simple hand tools.

Material: 6061 Aluminum

Finish: Clear Anodize

[Miniature]

Select and order separately 1/4 x .5" button or socket head capscrews and T-Nut from Fastening Hardware section

MOUNTING COMPONENTS

Extrusion Corners / 45° Supports — Standard & [Miniature]

Extrusion corners /45° supports are designed to strengthen corners and provide a flush and clean connection. The support connects with hardware consisting of socket head cap screws, washers and economy T-nuts (hardware Included).

Material: 6061-T6 Aluminum

Finish: Clear Anodize

PIC-STIX Extrusion Part Number	A (Inches)	Corner Part Number
SX1010L	4.00	SCX1010-4
SX1515L	3.00	SCX1515-3
SX1515L	9.00	SCX1515-9
SX1515	3.00	SCX1515-3
SX1515	9.00	SCX1515-9
SX1530	3.00	SCX1530-3
SX1530	9.00	SCX1530-9
SX3030	3.00	SCX3015-3
SX3030	9.00	SCX3015-9
SX1010M	6.00	SCX1010M-6
SX1020M	6.00	SCX1020M-6

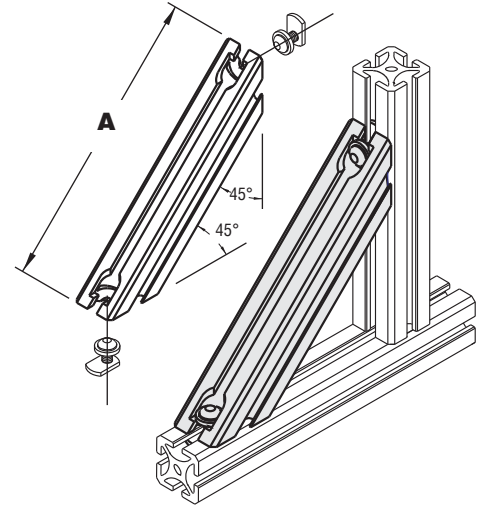

MOUNTING BRACKETS

Panel Mounting Angle, Corner Joint & Straight Bracket — Standard & [Miniature]

Corner Brackets

Use with extrusion part numbers SX1010L and SX1015L. Requires SCH8-05 screw and SCH2-10 nut (2ea).

Material: Aluminum

Finish: Clear Anodize

SCX1010-1

[SCX1010M-1 requires SCH8M-05 & SCH2M-10 Nut, 2 each]

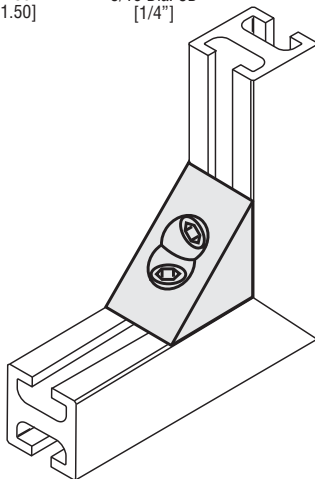
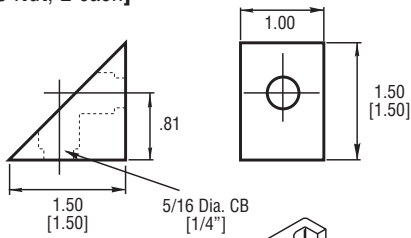

Panel Mounting Angle

Requires SCH9-06 and nut, plus appropriate panel mounting hardware.

Material: Aluminum

Finish: Clear Anodize

SCB1

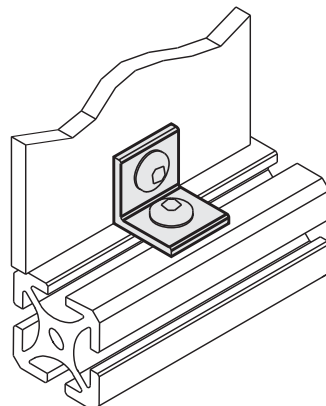
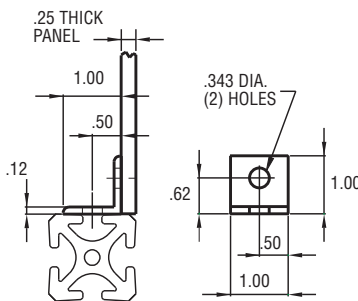

Corner Joint and Panel Bracket

Hardware Included. Access hole suggested for tightening screw.

Material: Aluminum

Finish: Clear Anodize

SCB1-CP

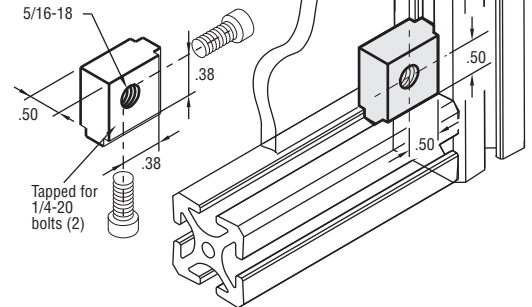

Panel Mount

Hardware Included.

Material: Aluminum, **Finish:** Clear Anodize

SCB1-P

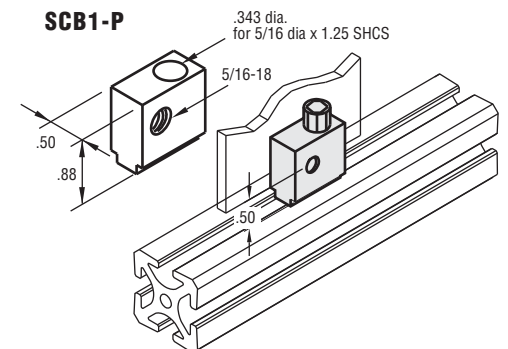

MOUNTING COMPONENTS

Adjustable Joint and Steel Corner Braces — Standard & [Miniature]

Adjustable Joint Connector

Suggested hardware SCH8-06 screw with T-Nuts (2).
Material: Aluminum
Finish: Clear Anodize
SCB2

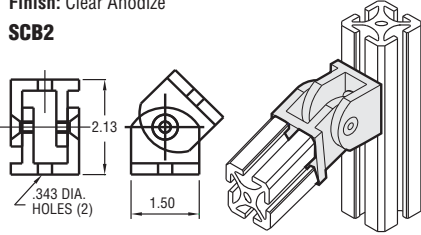

Reinforced Corner Brace

Suggested hardware SCH9-06 screw and SCH1 nut (4).
 [SCH9M-04 screw and SCH2M-10 nut (4)]
Material: Alloy Steel
Finish: Black Powder Coat

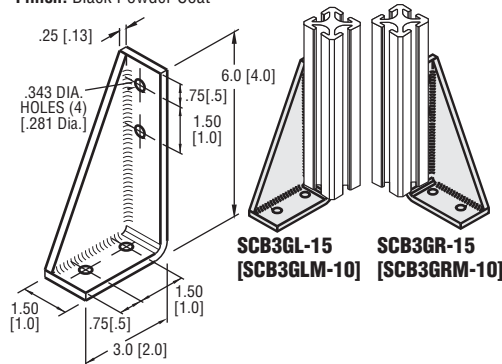

Corner Brace

Suggested hardware SCH9-06 screw and SCH1 nut (4).
 [SCH9M-04 screw and SCH2M-10 nut (4)]
Material: Alloy Steel
Finish: Black Powder Coat

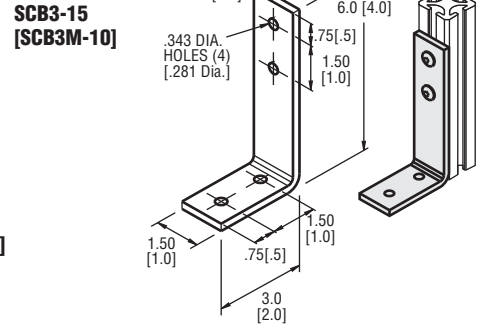

Corner Brace Reinforced

Suggested hardware SCH9-06 screw and SCH1 nut (8).
 [SCH9M-04 screw and SCH2M-10 nut (8)]
Material: Alloy Steel
Finish: Black Powder Coat

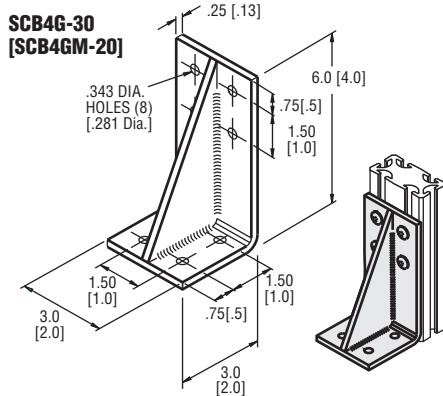

Corner Brace

Suggested hardware SCH9-06 and SCH1 nut (8).
 [SCH9M-06 screw and SCH2M-10 nut (8)]
Material: Alloy Steel
Finish: Black Powder Coat

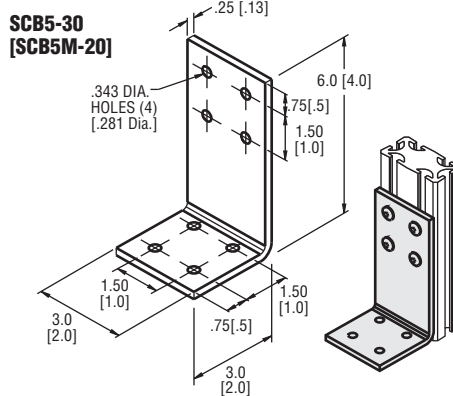

Corner Block

Material: Aluminum
Finish: Clear Anodize
SCB6
[SCB6M]

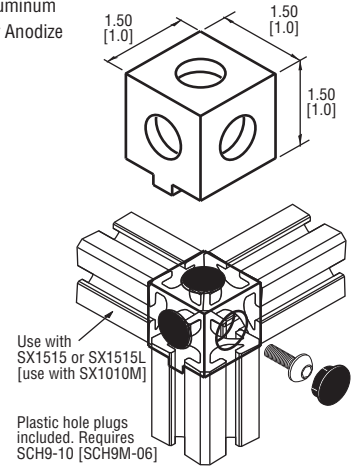

FASTENING HARDWARE — STANDARD & [MINIATURE]

Pivot T-Nuts

Loads into extrusion from the side.
 Not to be used on SX1010L and SX1015L.

SCH1-P
[SCH1M-P]

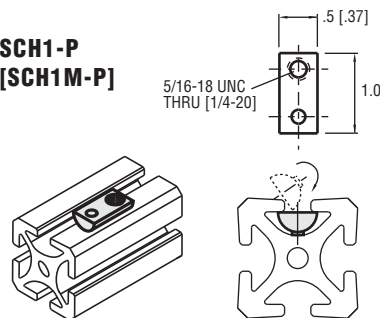

Material: Alloy Steel
Finish: Zinc Plate

Connector T-Nuts

Loads into extrusion from end only.

SCH1

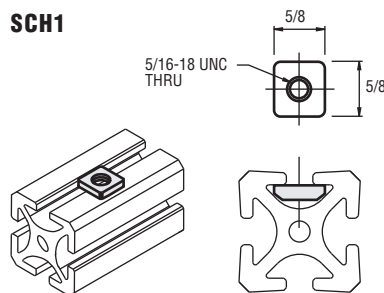

Economy T-Nuts

SCH2-15 Long T-Nut
[SCH2M-15]

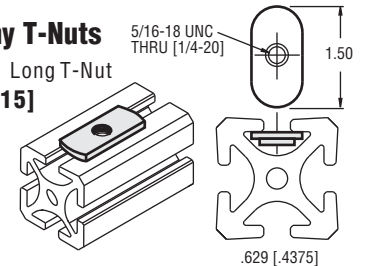

SCH2-10 T-Nut
[SCH2M-10]

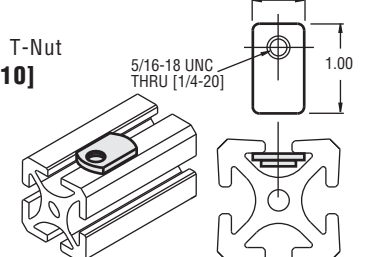

FASTENING HARDWARE

Standard Connectors

Single Anchor Fastener for 5/16" Slots

Hardware Included.

SCH3R

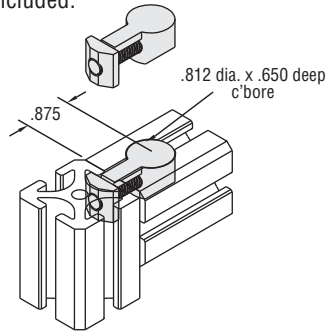

Double Anchor Fastener for 5/16" Slots

Hardware Included.

SCH3-15R
for L = 1.5"
SCH3-30R
for L = 3.0"

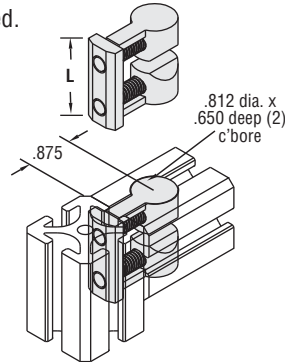

Butt Connector Standard 5/16" Slots

Hardware Included.

SCH4R

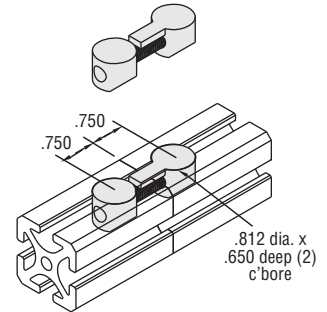

Anchor Butt Connector for Miniature 1/4" Slots

Hardware Included.

SCH4M

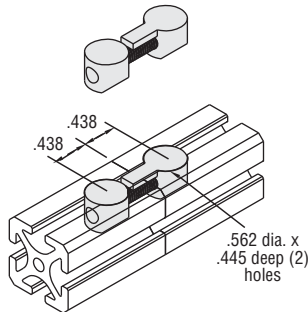

Single Cross Connector for Miniature 1/4" Slots

Hardware Included.

SCH3M

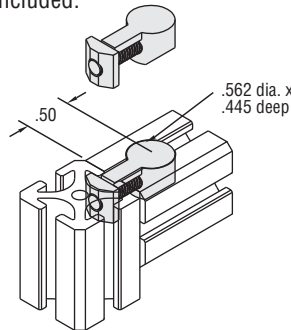

Double Anchor Fastener for Miniature 1/4" Slots

Hardware Included.

SCH3M-10
L or length = 1"
SCH3M-20
L or length = 2"

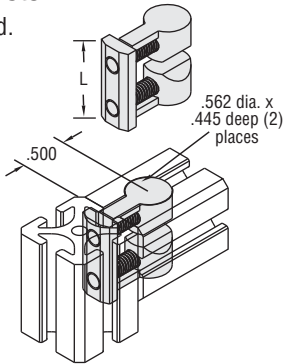

Material: Alloy Steel
Finish: Zinc Plate

5/16 Inch Washers, Nuts and Fasteners — Standard & [Miniature]

5/16" Washers [1/4"]

Sold in 10 piece increments

SCH6
[SCH6M]

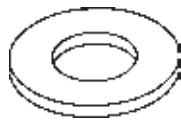

Material: Hardened Steel
Finish: Black Oxide Coat

Serrated Belleville

Sold in 10 piece increments

SCH6-1



Material: Steel
Finish: Black Oxide Coat

5/16" - 18 Hex Nuts [1/4"-20]

Sold in 10 piece increments

SCH6-2
[SCH6M-2]



Material: Steel
Finish: Zinc Plate

Push Lock Fastener

Sold in 10 piece increments

Material: Black Plastic

SCH5
[SCH5M]

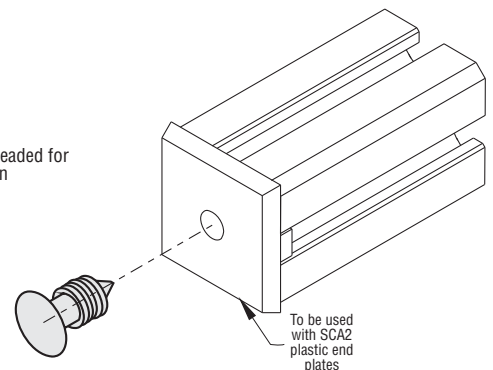
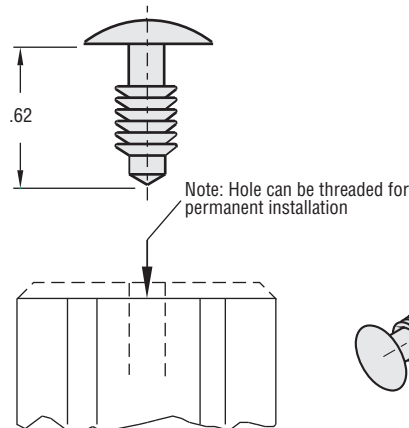

FASTENING HARDWARE

Fasteners / T-Slot Bolts and Screws — Standard & [Miniature]

Drop In And Turn 5/16" - 18 T-Bolts

Loads into extrusion from side.

Material: Alloy Steel
Finish: Zinc Plate

L (Inch)	Part Number
.75	SCH6-07
1.00	SCH6-10

SCH6- □ □

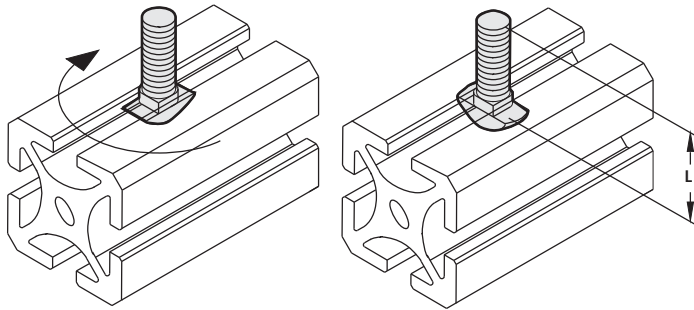

5/16" - 18 Standard Socket Head Cap Screws [1/4"-20]

Sold in increments of 10 pieces.

Material: Alloy Steel
Finish: Black Oxide

Standard Screws

L (Inch)	Part Number
.50	SCH8-05
.63	SCH8-06
.75	SCH8-07
1.0	SCH8-10
1.25	SCH8-12
1.5	SCH8-15
2.0	SCH8-20

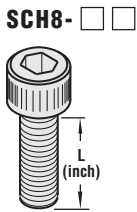

Miniature Screws

L (Inch)	Part Number
.44	SCH8M-04
.50	SCH8M-05
.63	SCH8M-06
.75	SCH8M-07
1.0	SCH8M-10
1.25	SCH8M-12

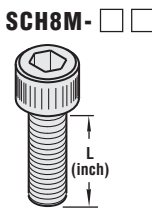

Economy 5/16" - 18 T-Bolts

Loads from end only. Sold in increments of 10 pieces.

Material: Alloy Steel
Finish: Zinc Plate

L (Inch)	Part Number
.75	SCH7-07
1.00	SCH7-10
1.25	SCH7-12
1.50	SCH7-15
2.00	SCH7-20

SCH7- □ □

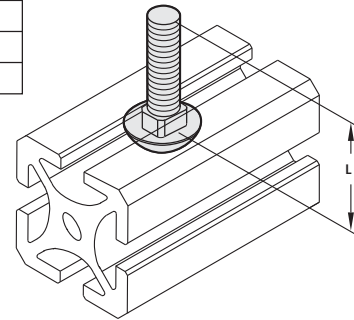

5/16" - 18 Standard Button Head Cap Screws [1/4"-20]

Sold in increments of 10 pieces.

Material: Alloy Steel
Finish: Black Oxide

Standard Screws

L (Inch)	Part Number
.50	SCH9-05
.63	SCH9-06
.75	SCH9-07
1.0	SCH9-10
1.25	SCH9-12
1.5	SCH9-15

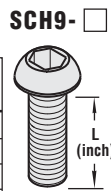

Miniature Screws

L (Inch)	Part Number
.44	SCH9M-04
.50	SCH9M-05
.63	SCH9M-06
.75	SCH9M-07
1.0	SCH9M-10
1.25	SCH9M-12

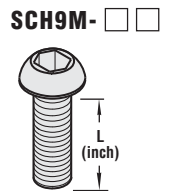

ACCESSORIES

Door Tracks, Plastic End Plates, Gasket and Covers — Standard & [Miniature]

Plastic End Plates

Use with part number SCH5. Color: Black

SCA2- □ □ □ □

SCA2-1515

For extrusion SX1515
[SCA2M-1010] for SX1010M



SCA2-1530

For extrusion SX1530 [SCA2M-1020]
for SX1020M



SCA2-3030

For extrusion SX3030
[SCA2M-2020] for SX2020M

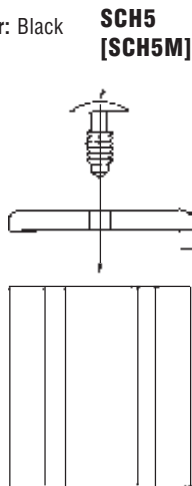
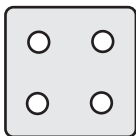

Plastic T-Slot Cover and Panel Gasket

Sold in 6 foot lengths.

SCA3 [SCA3M] — Gray

SCA3Y [SCA3YM] — Yellow

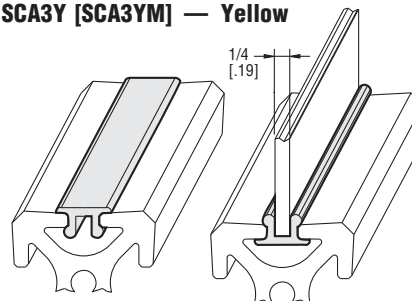

T-Slot Cover

Panel Gasket

ACCESSORIES

Leveling, Anchor and Caster Plates. Adjustable Legs and Casters — Standard & [Miniature]

Leveling Plate

Requires SCH8-10(2) [SCH8M-10].
Use with SCE4 [SCE4M] adjustable leg.

Material: Aluminum
Finish: Clear Anodize

SCE1 [SCE1M]

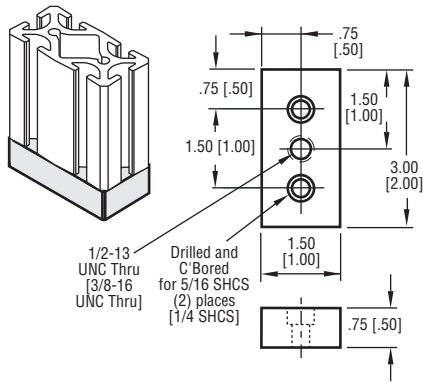

Leveling Plate

Requires SCH8-10(4) [SCH8M-10].
Use with SCE4 [SCE4] adjustable leg.

Material: Aluminum
Finish: Clear Anodize

SCE2 [SCE2M]

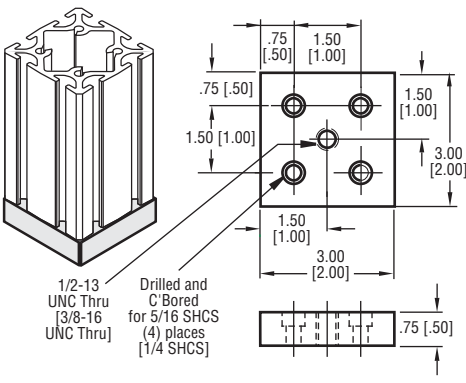

Leveling Anchor Plate

Requires SCH8-10(4) [SCH8M-10].
Use with SCE4 [SCE4M] adjustable leg.

Material: Aluminum
Finish: Clear Anodize

SCE2-A [SCE2M-A]

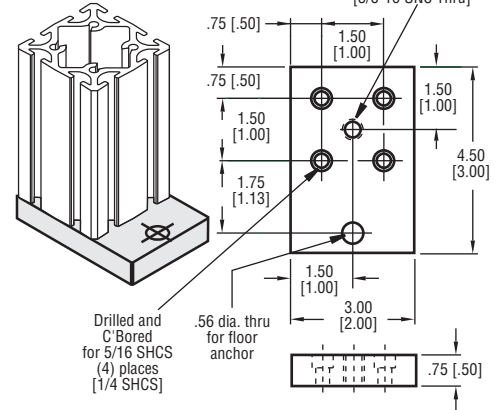

Leveling Anchor Plate

Requires SCH8-10(2) [SCH8M-10].
Use with SCE4 [SCE4M] adjustable leg.

Material: Aluminum
Finish: Clear Anodize

SCE1-A [SCE1M-A]

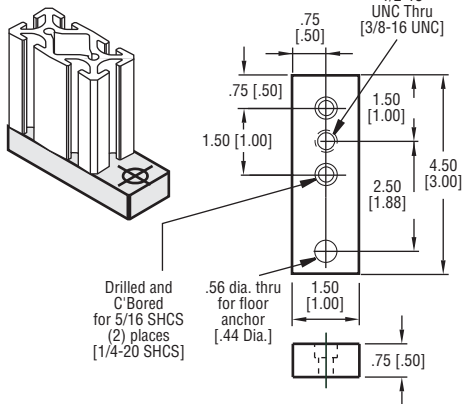

3" and 4" Caster Plate

Requires SCH8-10(4).
Use with SCE5 caster.

Material: Aluminum
Finish: Clear Anodize

SCE3 [SCE3M]

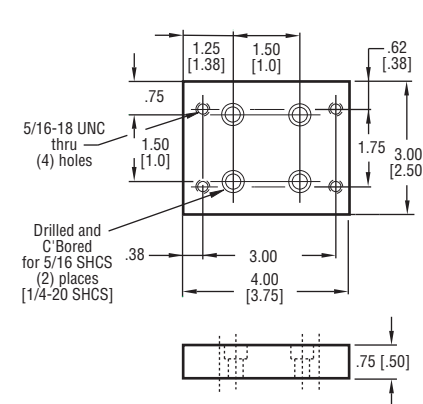

Adjustable Leg

1,800 pound maximum capacity.

Material: Steel
Finish: Bronze Coating

SCE4 [SCE4M]

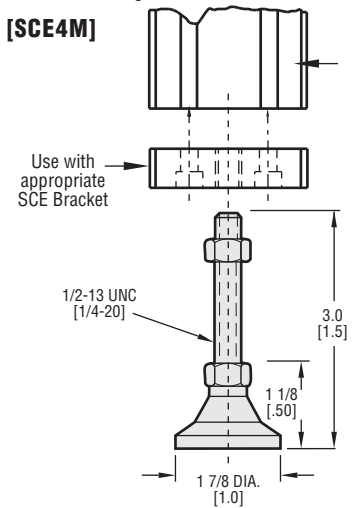

3" and 4" Caster

Use with SCE3 caster plate (see above).

SCE5-

Description	Part Number
3" caster-swivel	SCE5-3S
3" caster-fixed	SCE5-3F
3" caster-swivel / brake	SCE5-3B
4" caster-swivel	SCE5-4S
4" caster-fixed	SCE5-4F
4" caster-swivel / brake	SCE5-4B

3" Caster

SCE5-3 (SCE5-3B shown)
90 pound maximum capacity.

SCE5-3

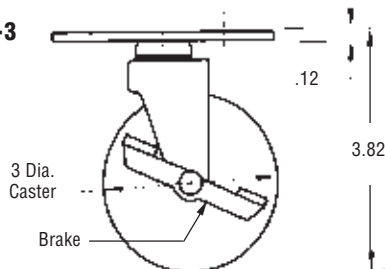

4" Caster

SCE5-4 (SCE5-4F shown)
130 pound maximum capacity.

SCE5-4

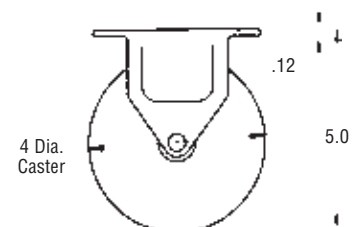

ACCESSORIES

Standard & [Miniature]

T-Slot Roller

Ideal for guided linear applications, mount to extrusion end or T-Slot; rolls in the mating T-Slot. Hardware included.

Material: Delrin with Bronze Bearing

Color: White

SCA6 [SCA6M]

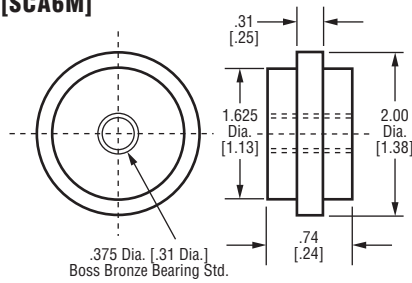

Plastic Handle

Color: Black.
Hardware included.

SCA9-3 [SCA9M-3]

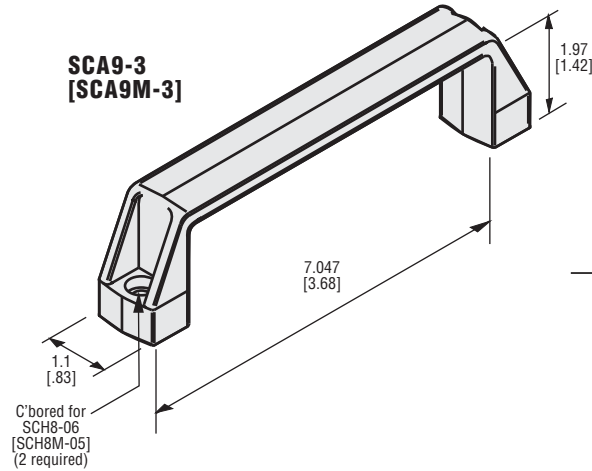

Aluminum Handle

Finish: Clear Anodize.
Hardware included.

SCA9-2

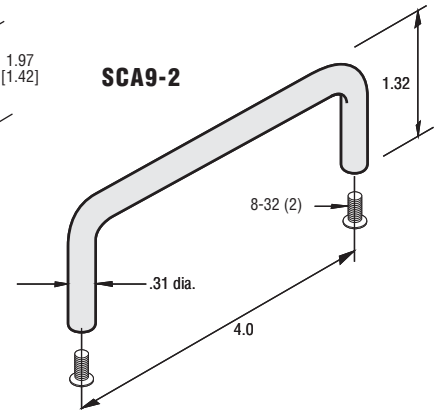

Plastic Hinge

Hardware included.
Color: Black.

SCA7-1

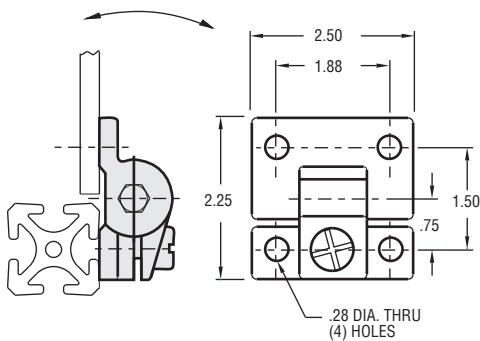

Aluminium Hinge

Finish: Clear Anodize.

SCA7-2

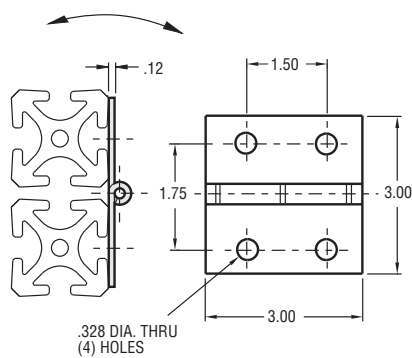

Magnetic Door Latch Assembly

Hardware included.
Material: Plastic with metal magnet
Color: Brown

SCA8

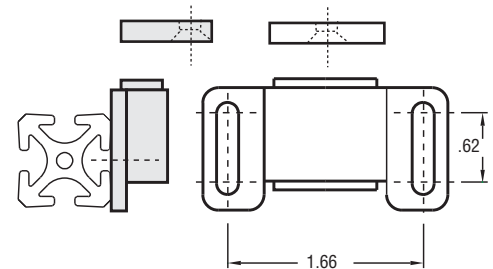

EXTRUSION END FINISHING

Ordering Information

When ordering aluminum extrusions specify quantity, part number with length. Example: **SX1515-144** for standard 144" lengths.

You may also order extrusions cut to your desired length with a nominal cutting charge. Example: **SX1515-72.25** for length of 72 1/4".

Length Tolerance: Standard saw cut lengths $\pm 1/32$
Precision milled cut lengths $\pm .005$. If precision milled cut desired, add P to end of part number

Example: **SX1515-24P** for length of 24" $\pm .005$

Lengths shorter than 106" can be shipped by UPS. Lengths over 106" will be shipped by commercial carrier with longer delivery times and increased costs.

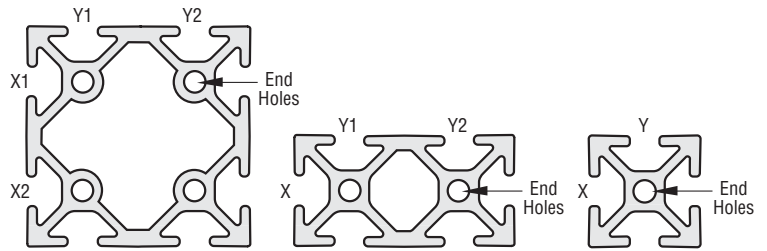

Predrilled access, connector and tapped holes available.
Call factory for information and quotations.

When ordering predrilled access holes, connector holes and tapped end holes, specify T-Slot location and at which end holes are to be drilled.

DO IT YOURSELF DETAILS — STANDARD

Mounting Hole Positions For Cross and End Fasteners

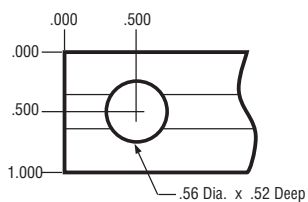

For SX1010L & SX1015L

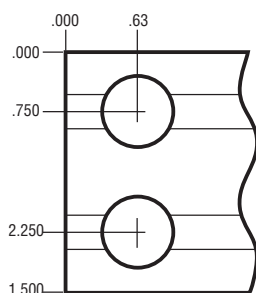

For SX1530 & SX3030

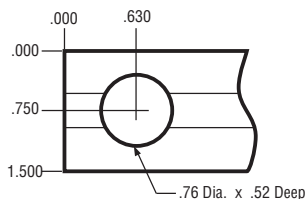

For SX1515L & SX1515

Access Holes For Corner Brackets

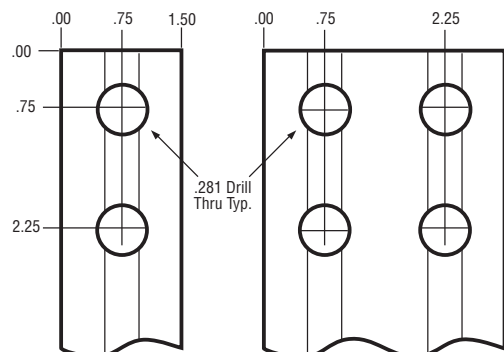

For SX1515L & SX1515

For SX1530 & SX3030

45° Supports

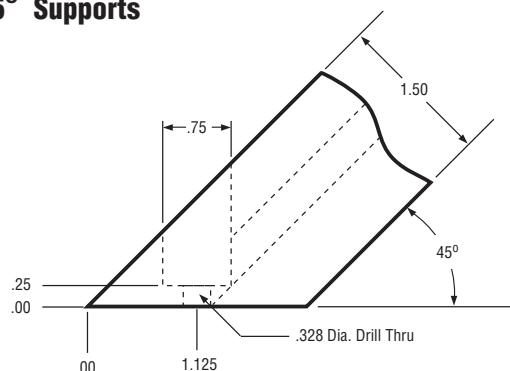
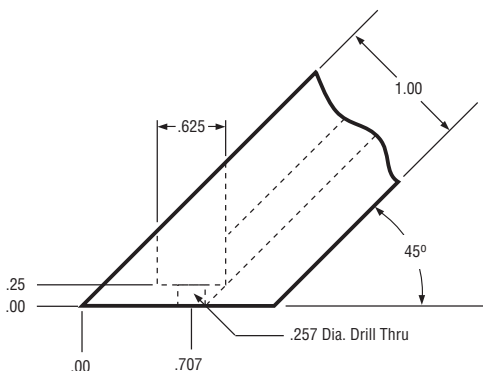

PIC Design Educational Kits are ideal for instruction in the use and application of precision industrial components. Standard stainless steel and aluminum parts are used throughout. These parts meet the same high quality standards as the rest of the parts in the PIC product line. No-Mar set screws allow repeated assembly and disassembly of components without marring of shafts.

All components contained in PIC Educational Kits are standard and available from PIC. Kits are supplied in rugged carrying cases designed to fully protect the precision instrument parts.

Select the Educational Kit that is best suited to teaching the principles of the electro-mechanical world around us.

EDUCATIONAL KIT KE-120 SERIES

PIC Design Educational Gear Kits enable dynamic demonstrations in the classroom on such subjects as: Torque, Gear Trains, Gear Terminology and Mechanics, Efficiency and Advantage. In addition Force Transmission and Loads in systems such as beams, bearings, machine members, and fasteners utilizing standard gears, shafts, bearings and pillow blocks can be demonstrated.

All Kits use superior quality mechanical components complete with bread-board mounting plate, legs and feet. A comprehensive easy-to-understand Instructors Manual provides step-by-step instructions for classroom tested demonstrations. Color-coded component illustrations in the instruction manual are ideal for projection in lecture halls to large classes. These demonstrations have proven their usefulness in such courses as: Physics, Machine Design, Mechanical Drawing, Design Drafting, Strength of Materials, Mechanics, Mechanisms and Kinematics.

Educational Kits come in polished wood carrying cases. These cases feature cabinet-maker precision detailing with a removable compartment tray used to store the precision mechanical components.

Series 120 Kits cover the complete range from The Starter Kit to Electro-Mechanical Systems.

STARTER KIT KE-120

The basic starter kit employs spur gears and is used as an introduction to the fundamentals of gearing. The kit also aids in the student's ability to clearly understand various technical concepts by hands-on demonstrations. This kit contains 113 components along with an instructor's manual to conduct 14 demonstrations.

UPGRADE KIT KE-120A

This upgrade kit is a secondary kit in the 120 Series and introduces the student to various types of gearing, such as worm and worm gears, bevel (miter) gears, helical and herringbone gears, and a spiroid gear system. This kit utilizes the components of the KE-120 and should be used in conjunction with the KE-120. This kit contains 18 components along with an instructor's manual to conduct 10 demonstrations.

KE-120A components fit into the KE-120 wooden carrying case.



COMBINATION KIT KE-121

The KE-121 is a combination of Kits KE-120 and KE-120A. The kit utilizes the demonstrations in spur gears, worm and worm gears, bevel (miter) gears, helical and herringbone gears and a spiroid gear system. This kit contains 131 components, along with instructor's manuals to conduct 24 demonstrations.

EDUCATIONAL KITS

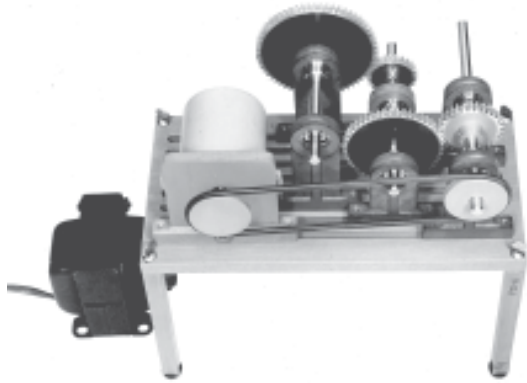

ELECTROMECHANICAL KIT KE-122

Precision mechanical trainer Kit KE-122 is an electromechanical kit designed for laboratory use by electromechanical and mechanical technology and engineering students. The DC motor and power supply enable the instructor to perform electromechanical systems experiments. Electromechanical systems such as belt and gear drives utilizing various types of gearing, including spur, worm, bevel, helical and herringbone demonstrates the basic concepts to the thrust generated from a set of helical and herringbone gears with the motor energized. This kit contains 152 components, along with an instructor's manual, to conduct 16 experiments.

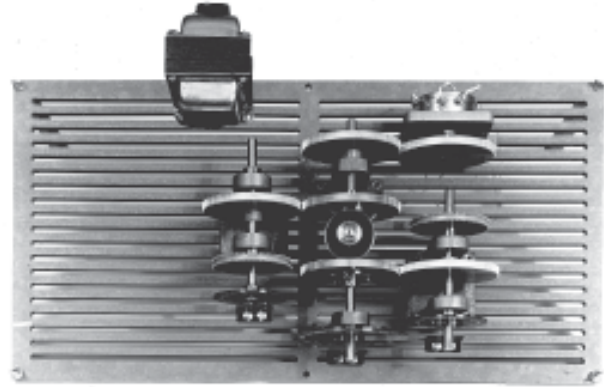

ELECTROMECHANICAL KIT KE-140

Kit KE-140 is a motorized trainer that enables the student to measure and observe the effects of transducer input and output, feedback, proportional control, motor speed characteristics, response time, lead lag, gear ratios, loading and analog control. Each experiment is designed to be performed slowly, so that it can be observed easily by the student. Each experiment builds upon the previous one, advancing from basic to simple and then to complex systems. The mechanisms used in this kit are typical of those used in the control industry. This permits the student to work directly with precision industrial components and to make modifications in the system and immediately observe the results. This kit contains 178 components, along with instructor's manuals to conduct 9 experiments.



LINKAGE KIT KE-130

The linkage kit KE-130 is designed to contain all components needed to create a working model of any classical linkage mechanism. Unique design features encourage creative exploration of new and better ways to solve linkage problems. Design and build any basic linkage mechanism including 4-bar toggle, differential, slider crank, quick return, arabog, pantograph, scotch yoke, and computational. This kit permits infinite variations of linkage lengths and positions, so that the effects of various parameter changes can be instantly observed and measured.

This kit contains 171 components, along with instructor's manual to conduct 16 demonstrations.

KE-130 kits come in a convenient attache type carrying case. In addition to the instruction manual, a comprehensive 143 page book, "Applied Linkage Synthesis" by D. C. Tao is supplied. This book serves as a practical reference for engineers and provides students of kinematics with a problem's textbook on the dimensional synthesis of linkage mechanisms. Emphasis is placed on the design of such mechanisms as those used in computers, data processing equipment, teaching and navigation devices, control mechanisms in missiles, and electromechanical control components. In order to aid students in blending theory into practical engineering designs, the book contains basic graphic problem solving techniques for quick and accurate results.

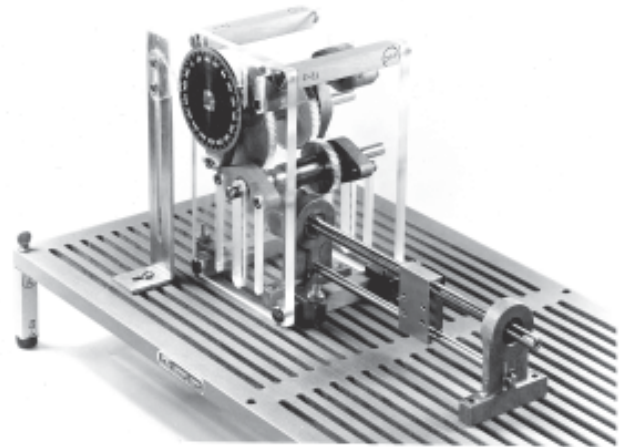

PRECISION MECHANICAL TRAINER KE-150

The KE-150 motorized kit is designed to provide the student with the opportunity to gain first hand experience in the building, testing and analyzing of mechanical mechanisms and drives which contain components that are used in the computer, control and aerospace industries. The student will gain a working knowledge of gears (all types), belts, chains, sprockets, cams, pulleys, screws, pillow blocks, universals, bearings, mechanisms and mechanical drivetrains that are commonly used in industries.

The KE-150 is designed to be used in conjunction with the action-oriented Lab-Text manual and instructor's guide which was developed and tested by TeRC (Technical Education Research Center) Electromechanical Technology Curriculum Development group at Oklahoma State University under a federal grant. This kit contains 296 components along with the Drives manual to conduct 30 demonstrations.

PRECISION BREADBOARD KITS

These practical, low cost complete kits of laboratory precision instrument components consist of gears, shafts, differentials, breadboard plates, hangers, bearings, etc. These kits can be used for Military Engineering or Development Contracts, Universities, Laboratories, Educational Institutions and other mechanical and electronic applications. The kit is contained in an attractive leather carrying case which is felt lined to protect the precision instrument components, along with the tools to assemble and disassemble. All components are for a 1/4" shaft size and are available in the following kits:

Kit No. "G" - 657 Parts Kit No. "N" - 515 Parts Kit No. "R" - 425 Parts



PARTS LIST— "G", "N", & "R" KITS

Name	Part No.	Quantity			Name	Part No.	Quantity			Name	Part No.	Quantity				
		"G"	"N"	"R"			"G"	"N"	"R"			"G"	"N"	"R"		
Shafting	A3-20	3	3	2	Clears	L2-1	6	4	2	Bellows Coupling	T1-3	1	1	1		
	A3-40	3	3	2		L2-2	6	4	2		Dialham Coupling	T2-3	1			
	A3-60	3	3	2		L2-3	6	4	2			Differential End Gears	V7	1		
	A3-80	3	3	2		L2-4	3	2	2				V8-1	1		
	A3-100	3	3	2		M1-9	1	1	1				V9-1	1		
Laminated Shim	B1-3	12	12	6	M1-16	1	1	1	V8-2	1						
Stainless Shim	B2-3	12	12	6	M2-7	1	1	1	V8-6	1						
Aluminum Spacers	B3-11 to 15	30	30	15	"Assem. with Bowl Gears"	K2-5 Hub	3	3	2	Dialham Coupling Handcrank Assembly	T5-3	1				
	B8-1 to 15	60	60	30		M3-1	1 Pr.				L1-3	2				
Collars	C1-3	12	6	4		M3-2	1 Pr.				W1-3	1	1	1		
	C1-3	12	6	4	M3-3	1 Pr.			T2-4-T		2	2	2			
Couplings	D1-3	4	2	1	Coupling	M4-3	1 Pr.				Y6-4	2	2	2		
	E1-9	16	12	8		AD-1F	1	1	1	W2-1	1	1	1			
Gears	G3-60	2	1	1	AD-1F	1	1	1	Shaft Ext. Screws	AL-9	1	3				
	G4-60	2	1	1	P4-1-80	1	1			Y1-6-X	25	25	25			
	G3-72	2	1	1	P4-1-132	1	1		Y1-8-X	50	50	50				
	G4-72	2	1	1	Index	M3-1	2	1	1	Y6-6	25	25	25			
	G3-85	2	1	1	Worm Gears	M3-2	2	1	1	Lockwashers	Y6-8	50	50	50		
	G4-85	2	1	1		Q1-9	1	1	1		Y6-9	50	50	50		
	G3-100	2	1	1	Q1-12	1	1	1	Retainer Rings		Z1-3	12	10	12		
	G4-100	2	1	1	Q2-3	1	1	1			Z2-3	12	10	12		
	Split Hub Type	H1-21	2	1	1	Worm Shaft Hangers	R1-9	4	4		2	Breadboard Plate	B82	2	1	1
		H2-21	2	1	1		R1-10	4	4	2	Legs		F2-4	6	6	6
		H1-22	2	1	1	R1-11	4	4	2	Bumpers		F2-6	6	6	6	
		H2-22	2	1	1	R1-12	4	4	2		B85	12	6	6		
		H1-30	2	1	1	Dial Hanger Slip Clutch Component Hangers	AN-3T	1	1		1	Y1-8-U	12	6	6	
		H2-30	2	1	1	S1-1	1	1	1	Wing Screws	B83	14	6	6		
		H1-38	2	1	1	S1-2	1	1	1		B84	50	30	20		
H2-36	2	1	1	S1-3	1	1	1	Washers	Y7-6		50	30	50			
H1-44	2	1	1	S1-4	1	1	1		Tools	8	8	8				
H2-44	2	1	1	S1-5	1	1	1	Case	1	1	1					
Gears Hubless	J1-60	1	1	1	S1-6	1	1	1								
	J1-72	1	1	1	S1-7	1	1	1								
Clamps	J1-90	1	1	1	S1-8	1	1	1								
	L1-3	18	12	7	S1-9	1	1	1								
					S1-10	1	1	1								

PRECISION TOOLS

SOCKET HEAD KEYS & SETS



Material: Alloy Steel (Black Finish)

For a set of hex socket head keys containing 8 keys from .035 to 3/16" key size — in case.

Order CS-50

Set Screw Size	Cap Screw Size	Key Size	Part Number
#2		0.035	CS-40
#4		0.05	CS-41
#6		1/16	CS-42
#8	#2	5/64	CS-43
#10	#4	3/32	CS-44
1/4		1/8	CS-45
5/16	#10	5/32	CS-46
3/8	1/4	3/16	CS-47

SPEED REDUCER & GEAR HEADS

MECHANICAL SPECIFICATIONS DATA

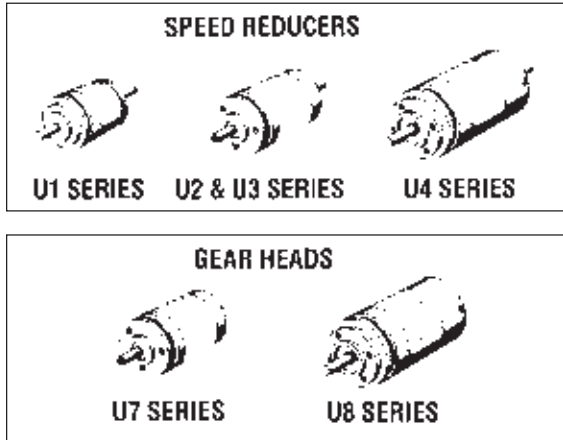

Specification	U1 Series	U2, U3 & U7 Series	U4 & U8 Series
Maximum Rated Output Torque	40 oz. in.	65 oz. in.	125 oz. in.
Frame Size and Diameter of Unit	Size 10, 15/16 Dia.	Size 11, 1 1/16 Dia.	Size 18, 1-3/4 Dia.
Shaft Size	1/8" Dia. & 3mm	1/8" Dia. & 3mm	1/4" Dia. & 6mm
Max. Operating Load Torque	25 oz. in.	30 oz. in.	65 oz. in.
Starting Torque (Max.)	004 oz. in.	005 oz. in.	03 oz. in.
Backlash (Max.) Measured at Output Shaft with 5 oz. in. Rev. Load	30 Min. (Max.)	30 Min. (Max.)	30 Min. (Max.)
Lubricated Per MIL Specs	Oil Per MIL-L-6085a Grease Per MIL-G-23827a		
Ball Bearings	ABEC 5 or Better		
Gear Toolerances	D12 or Better		
Shaft Radial Play	With 4 oz. Gage Load .002 in. Per In. Length Max.		
Shaft End Play	With 1 Lb. Gage Load .004 in. Max.		
Weight (Approx.)	2 oz.	3 oz.	8 oz.
Moment of Inertia at Input Shaft (Approx.)	.007 Gm-Cm ²	.015 Gm-Cm ²	.135 Gm-Cm ²
Use with PIC Breadboard Hanger	S1-10 Modified	S1-8	S1-3

PRECISION SPEED REDUCER

Inch and Metric Input and Output Shafts ■ 15/16" Dia. ■ Size 10

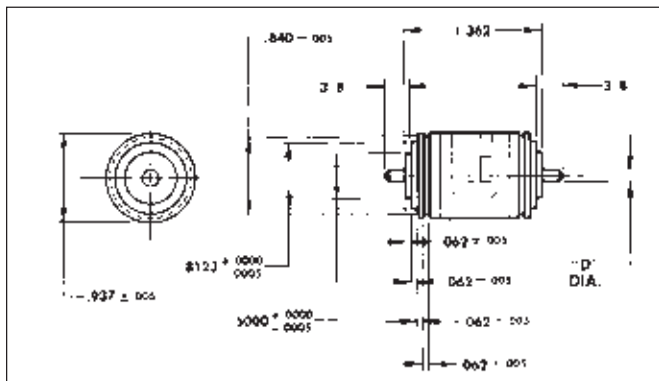

"D" DIMENSION

Inch	1250	⁰⁰⁰⁰ / ₀₀₀₅
Metric	2993	⁰⁰⁰ / ₀₀₅

No. of Gear Clusters	Shaft Direction of Rotation	Gear Ratio	Inch Part No.	Metric Part No.
1	Same	9.50:1	U1-1	MSR1-1
		20.19:1	U1-2	MSR1-2
		30.08:1	U1-3	MSR1-3
3	Same	39.36:1	U1-4	MSR1-4
		50.14:1	U1-5	MSR1-5
		75.14:1	U1-6	MSR1-6
		100.56:1	U1-7	MSR1-7
4	Opposite	150.42:1	U1-8	MSR1-8
		199.50:1	U1-9	MSR1-9
		301.67:1	U1-10	MSR1-10
5	Same	400.73:1	U1-11	MSR1-11
		502.78:1	U1-12	MSR1-12
6	Opposite	1000.27:1	U1-13	MSR1-13
		2003.39:1	U1-14	MSR1-14
		3025.07:1	U1-15	MSR1-15

For Special Ratios, Consult Factory

Ball Bearings Throughout Unit.
 Max. Rated Output Torque: 40 Oz. in.
 Backlash through entire gear train less than 30'

PRECISION SPEED REDUCER

Inch and Metric Input and Output Shafts ■ 1 1/16" Dia. ■ Size 11

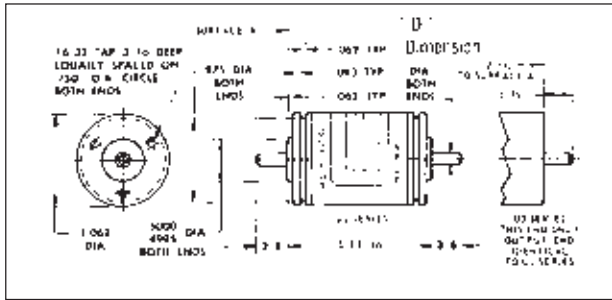

"D" DIMENSION

Inch	1.750 $\pm \frac{0.002}{0.002}$
Metric	44.143 $\pm \frac{0.051}{0.051}$

Ball Bearings Throughout Unit
 Max. Rated Output Torque: 65 Oz-in
 Backlash through entire gear train less than 30"

No. of Gear Clusters	Shaft Direction of Rotation	*Gear Ratio (Exact)	Inch Part No. **	Metric Part No. ***
1	Same	9:1	U2-1	MSR2-1
		10:1	U2-2	MSR2-2
		12:1	U2-3	MSR2-3
		15:1	U2-4	MSR2-4
		20:1	U2-5	MSR2-5
		25:1	U2-6	MSR2-6
2	Opposite	30:1	U2-7	MSR2-7
		40:1	U2-8	MSR2-8
		50:1	U2-9	MSR2-9
2	Opposite	60:1	U2-10	MSR2-10
		80:1	U2-11	—
3	Same	90:1	U2-12	MSR2-11
		100:1	U2-13	MSR2-12
		120:1	U2-14	—
		200:1	U2-15	MSR2-13
4	Opposite	300:1	U2-16	MSR2-14
		360:1	U2-17	MSR2-15
		400:1	U2-18	MSR2-16
		500:1	U2-19	—
5	Same	600:1	U2-20	MSR2-17
		800:1	U2-21	—
		1000:1	U2-22	MSR2-18
		2000:1	U2-23	—
6	Opposite	3000:1	U2-24	MSR2-19
		3800:1	U2-25	MSR2-20

** Shaft length is 3.8 in
 *** Shaft length is 97.16 in
 † In Speed Tables, Consult Factory

PRECISION SPEED REDUCER

Inch and Metric Input and Output Shafts ■ 1 3/4" Dia. ■ Size 18

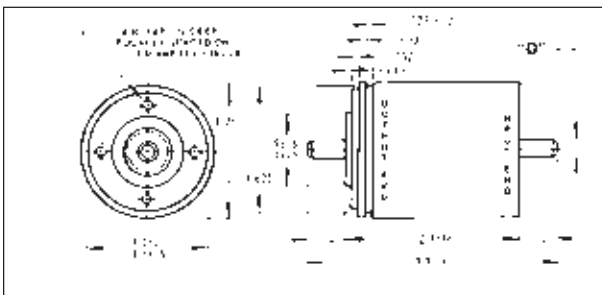

"D" DIMENSION

Inch	2.500 $\pm \frac{0.002}{0.002}$
Metric	63.500 $\pm \frac{0.051}{0.051}$

Ball Bearings Throughout Unit
 Max. Rated Output Torque: 175 Oz-in
 Backlash through entire gear train less than 30"

No. of Gear Clusters	Shaft Direction of Rotation	*Gear Ratio	Inch Part No.	Metric Part No.
1	Same	4.96:1	U4-1	MSR3-1
		6:1	U4-2	MSR3-2
2	Opposite	9.93:1	U4-3	MSR3-3
		15.27:1	U4-4	MSR3-4
3	Same	23:1	U4-5	MSR3-5
		30:1	U4-6	MSR3-6
4	Opposite	40:1	U4-7	MSR3-7
		50:0:1	U4-8	MSR3-8
		60:1	U4-9	MSR3-9
		100:1	U4-10	MSR3-10
5	Opposite	124.8:1	U4-11	—
		150:1	U4-12	MSR3-11
		200:1	U4-13	MSR3-12
		248.76:1	U4-14	MSR3-13
		300:3:1	U4-15	—
		400:1	U4-16	MSR3-14
		500:1	U4-17	MSR3-15
6	Opposite	600:1	U4-18	MSR3-16
		1300:1	U4-19	MSR3-17
		1600:1	U4-20	MSR3-18
6	Opposite	1800:1	U4-21	—
		2900:1	U4-22	—
6	Same	2900:1	U4-23	—
		2500:1	U4-24	MSR3-19
6	Same	3000:1	U4-25	MSR3-20

* In Speed Tables, Consult Factory

PRECISION GEAR HEADS

1 1/16" Dia. ■ Size 11

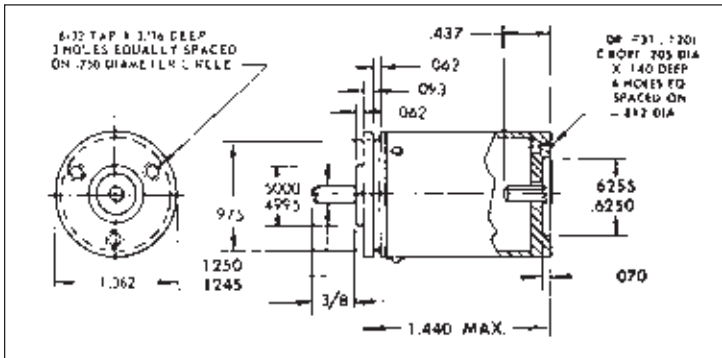

MOTOR PINION DATA	
Number of Teeth	13
Diametral Pitch	120
Pressure Angle	20°
Testing Pitch Radius	0.642 0.638
Outside Diameter	1.247

Ball Bearings Throughout Unit.
 Max. Rated Output Torque: 65 Oz. in.
 Backlash through entire gear train less than 30'
 Motor and Pinion Supplied by Customer.

No. of Gear Clusters	Shaft Direction of Rotation	*Gear Ratio	Part No.
1	Same	7.23:1	U7-1
		10.95:1	U7-2
		14.46:1	U7-3
		19.08:1	U7-4
2	Opposite	21.69:1	U7-5
3	Same	35.15:1	U7-6
2	Opposite	43.35:1	U7-7
3	Same	65.98:1	U7-8
		72.3:1	U7-9
		103.15:1	U7-10
4	Opposite	144.62:1	U7-11
		216.92:1	U7-12
		260.3:1	U7-13
		289.23:1	U7-14
		361.54:1	U7-15
		433.85:1	U7-16
5	Same	578.48:1	U7-17
		723.68:1	U7-18
		1443.15:1	U7-19
6	Opposite	2169.23:1	U7-20
5	Same	2603.38:1	U7-21
		3263.85:1	U7-22

*For Special Ratios, Consult Factory

PRECISION GEAR HEADS

1 3/4" Dia. ■ Size 18

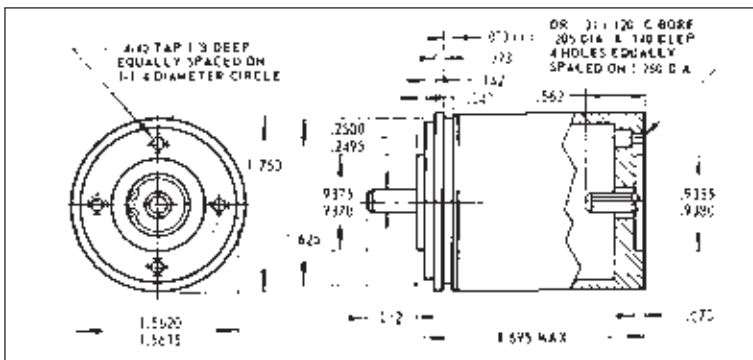

MOTOR PINION DATA	
Number of Teeth	15
Diametral Pitch	96
Pressure Angle	20°
Testing Pitch Radius	0.781 0.769
Outside Diameter	1.765

Ball Bearings Throughout Unit
 Max. Rated Output Torque: 125 Oz. in.
 Backlash through entire gear train less than 30'
 Motor and Pinion Supplied by Customer.

No. of Gear Clusters	Shaft Direction of Rotation	*Gear Ratio	Part No.
1	Same	7.67:1	U8-1
		16.60:1	U8-2
2	Opposite	25.20:1	U8-3
		35.60:1	U8-4
		42.76:1	U8-5
		67.20:1	U8-6
		84.00:1	U8-7
3	Same	104.90:1	U8-8
		120.00:1	U8-9
		168.00:1	U8-10
		208.46:1	U8-11
		252.26:1	U8-12
		336.00:1	U8-13
		420.00:1	U8-14
4	Opposite	504.00:1	U8-15
		840.00:1	U8-16
		1344.00:1	U8-17
		1680.00:1	U8-18
5	Same	2100.00:1	U8-19
		2520.00:1	U8-20
6	Opposite	3360.00:1	U8-21

*For Special Ratios, Consult Factory

PRECISION SERVO GEAR BOXES

1/4" Shaft ■ Ratios From 2:1 To 625:1 ■ ABEC-7 Ball Bearings

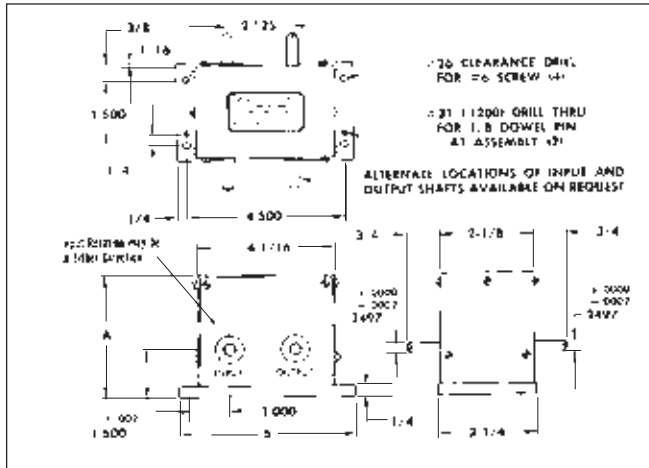

Material: Gears — 2024-T4 Aluminum Meshing
with 303 Stainless Steel Pinions
Housing — Aluminum (Black Anodize)

OPERATING CHARACTERISTICS

All Units Lubricated with
Mil Spec. Oil and Grease.

Maximum Speed	5000 rpm
Static Torque Rating (Output Max.)	900 gr-in
Backlash as Measured at Output Shaft with Input Shaft Locked	.30°

Exact Ratio	Direction of Rotation	A	Part No.	Exact Ratio	Direction of Rotation	A	Part No.
2:1	Same	3-9/32	ES-1	60:1	Opposite	3-13/16	ES-22
3:1			ES-2	64:1			ES-23
4:1			ES-3	75:1			ES-24
5:1			ES-4	80:1			ES-25
6:1			ES-5	130:1			ES-26
7:1	Same	3-9/32	ES-6	125:1	Same	4-13/16	ES-27
8:1			ES-7	72:1			ES-28
9:1			ES-8	90:1			ES-29
10:1			ES-9	96:1			ES-30
12:1			ES-10	128:1			ES-31
15:1	Same	3-9/32	ES-11	150:1	Same	4-13/16	ES-32
16:1			ES-12	180:1			ES-33
20:1			ES-13	200:1			ES-34
25:1			ES-14	250:1			ES-35
30:1			ES-15	256:1			ES-36
32:1	Opposite	3-13/16	ES-16	300:1	Same	4-13/16	ES-37
36:1			ES-17	375:1			ES-38
40:1			ES-18	400:1			ES-39
45:1			ES-19	500:1			ES-40
48:1			ES-20	625:1			ES-41
50:1	Opposite	3-13/16	ES-21				

Oil-impregnated Bronze Bearings Available. Consult Factory.
Precision Servo Gear Boxes with Anti Backlash Gears. Special Ratios Available. Consult Factory.

WORM & WHEEL ASSEMBLIES — 48 & 64 PITCH

Shafts ■ ABEC-7 Ball Bearings ■ 1/4" to 3/16" Shafts

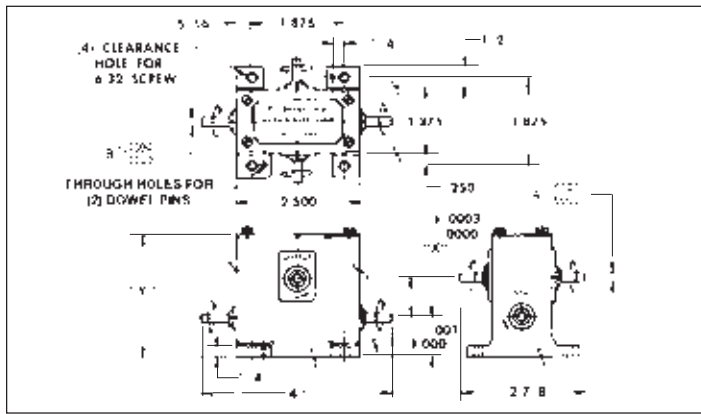

Material: Housing — Cast Aluminum (Anodized)
Worm — Stainless Steel
Wheel — Bronze
All Other Parts Stainless Steel
Lubricated with Mil-Spec. Oil & Grease.

OPERATING CHARACTERISTICS

All Units Lubricated with
Mil Spec. Oil and Grease.

Maximum Speed	2000 rpm
Static Torque Rating 48 Pitch	200 gr-in
Static Torque Rating 64 Pitch	150 gr-in
Backlash Through Entire Train Less than .175 mil (Dry) at End of Input Shaft — Cannot be Used as Speed Increaser Input Shaft may be Turned Either Direction	.30°

Pitch	Exact Ratio	A	B	X	Y	Part No.
48	12.5:1	2497	1872	8078	2-11/32	DJ-1
	15:1			7920	2-35/64	DJ-2
	20:1			10033	2-31/32	DJ-3
	22.5:1			11045	3-11/64	DJ-4
	25:1			6678	2-11/32	DJ-5
	30:1			7920	2-35/64	DJ-6
	40:1			10033	2-31/32	DJ-7
	45:1			11045	3-11/64	DJ-8
	53.1:1			6678	2-11/32	DJ-9
	60:1			7920	2-35/64	DJ-10
	60:1			10033	2-31/32	DJ-11
	90:1			11045	3-11/64	DJ-12
64	15:1	2497	2497	7130	2-11/32	DQ-1
	20:1			8753	2-5/8	DQ-2
	25:1			10315	2-31/32	DQ-3
	30:1			11878	3-1/4	DQ-4
	30:1			7130	2-11/32	DQ-5
	40:1			8753	2-5/8	DQ-6
	50:1			10315	2-31/32	DQ-7
	60:1			11878	3-1/4	DQ-8
	60:1			7130	2-11/32	DQ-9
	80:1			8753	2-5/8	DQ-10
	100:1			10315	2-31/32	DQ-11
120:1	11878	3-1/4	DQ-12			

Other Shaft diameters Available. Consult Factory.
Oil-impregnated Bearings Available. Consult Factory.



METRIC SERVO GEAR BOXES

All Dimensions In Millimeters

Shaft Diameter 6mm ■ Ratio 2:1 To 625:1

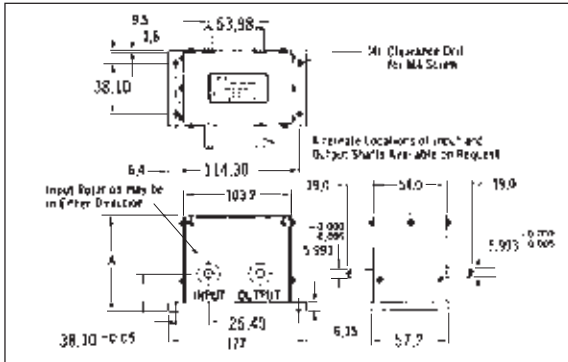

Gear Ratio	Shaft Direction of Rotation	A	Part No.
2:1	Same	83.3	MGB3-1
3:1			MGB3-2
4:1			MGB3-3
5:1			MGB3-4
6:1			MGB3-5
10:1	Same	83.3	MGB3-6
12:1			MGB3-7
15:1	Same	83.3	MGB3-8
16:1			MGB3-9
23:1			MGB3-10
25:1			MGB3-11
30:1	Opposite	96.8	MGB3-12
36:1			MGB3-13
40:1			MGB3-14

Special Shaft Sizes or Ratios Available. Consult Factory.
Available With Anti Backlash Gears. Consult Factory.

Gear Ratio	Shaft Direction of Rotation	A	Part No.
50:1	Opposite	95.8	MGB3-15
60:1			MGB3-16
80:1	Opposite	96.8	MGB3-17
100:1			MGB3-18
150:1	Same	122.2	MGB3-19
200:1	Same	122.2	MGB3-20
300:1			MGB3-21
400:1	Same	122.2	MGB3-22
500:1			MGB3-23
625:1			MGB3-24

OPERATING CHARACTERISTICS

Maximum Speed	3000 rpm
Static Torque Rating (Output) Max	154 N • m
Backlash as Measured at Output	30' Max
Shaft with Input Shaft Locked	361
361 Backlash Tolerance	ABEC 3

Material: Gears — Aluminum Meshing with
Stainless Steel Pinions
Housing — Aluminum (Black Anodize)

INTERMITTENT MOTION ASSEMBLY

48 Pitch Gears ■ 1/4" Shaft

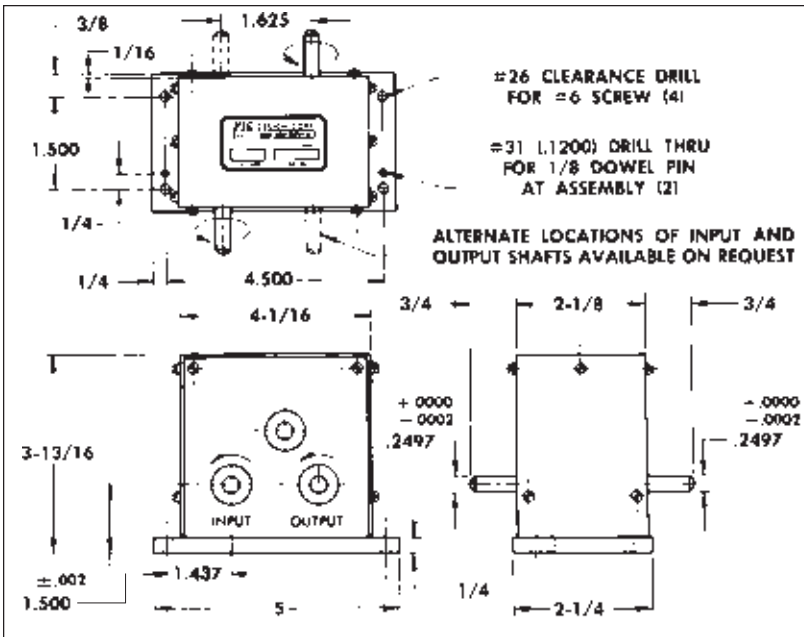

MATERIAL SPECIFICATIONS

Gears: 2024-T4 Aluminum Meshing with
303 Stainless Steel
Geneva: 303 Stainless Steel
Housing: Aluminum — Black Anodized
Lubricated with Mil Spec. Oil and Grease

OPERATING CHARACTERISTICS

Maximum Speed — 300 rpm
Input Travel — Either Direction and Reversible.
Backlash as Measured at Output Shaft with
Input Shaft Locked — 30'

*Degrees of Output Per Each Full Revolution of Input	Part No.
90°	EV-1
60°	EV-2
45°	EV-3
30°	EV-4
22°30'	EV-5
10°	EV-6

*2 Cam Followers on Driver Available. Consult Factory.
Special Output Angles, Shaft Sizes and Shaft Locations Available. Consult Factory.
Intermittent Motion Assemblies Available with Oil-Impregnated Bearings. Consult Factory.
Lightening Holes Optional. Consult Factory

GENEVA MECHANISMS

Intermittent Motion ■ 1/4" Shaft ■ 72° Motion

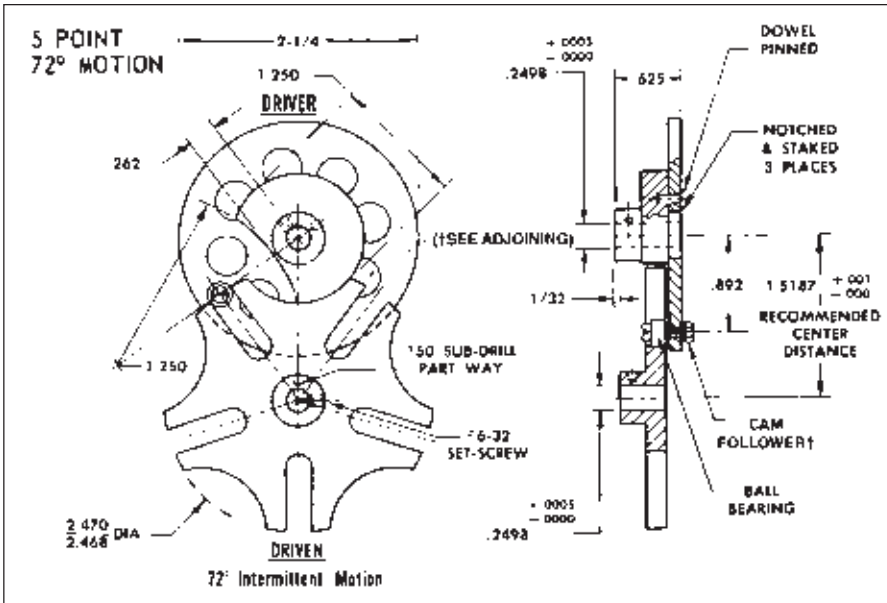

No. of Points	Intermittent Motion	Part No.
5	360° Driver = 72° Driven	EU-2

Driver Travel — Either Direction and Reversible
1/8" & 3/16" Shaft Units Available. Consult Factory

*Lighting Holes
Optional, on Request.

†2 Cam Followers
on Driver Available
on Request.

Material: 303 Stainless Steel

GENEVA MECHANISMS

Intermittent Motion ■ 1/4" Shaft ■ 90° Motion

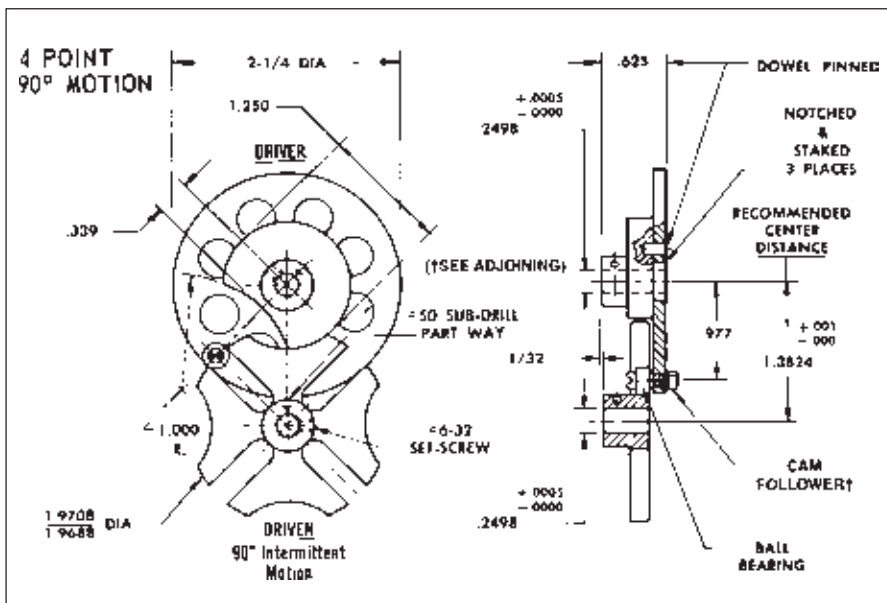

No. of Points	Intermittent Motion	Part No.
4	360° Driver = 90° Driven	EU-1

Driver Travel — Either Direction and Reversible
1/8" & 3/16" Shaft Units Available. Consult Factory.

*Lighting Holes
Optional, on Request.

†2 Cam Followers
on Driver Available
on Request.

Material: 303 Stainless Steel

GENEVA MECHANISMS

Intermittent Motion ■ 1/4" Shaft ■ 45° Motion

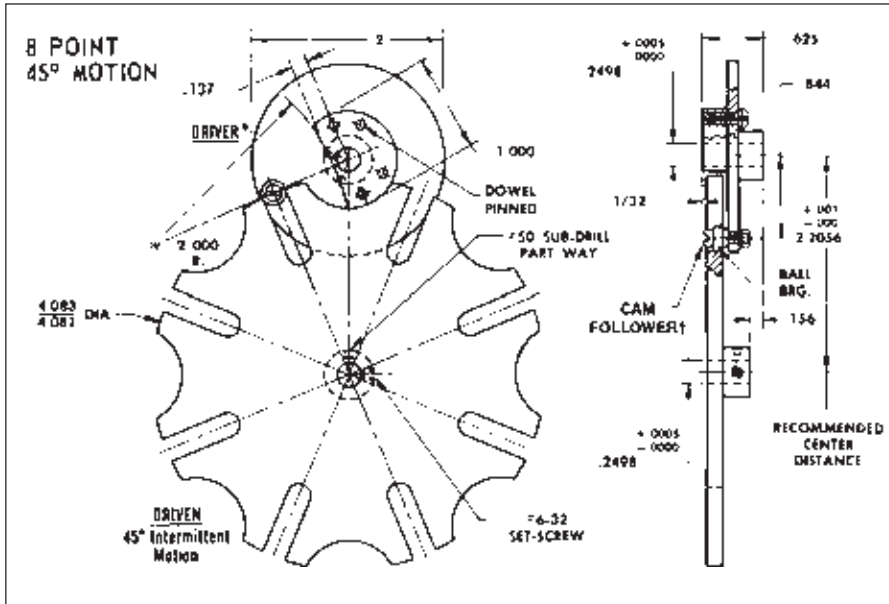

No. of Points	Intermittent Motion	Part No.
8	360° Driver = 45° Driven	EU-4

Driver Travel — Either Direction and Reversible
1/8" & 3/16" Shaft Units Available. Consult Factory.

*Lighting Holes
Optional, on Request.

†2 Cam Followers
on Driver Available
on Request.

Material: 303 Stainless Steel

GENEVA MECHANISMS

Intermittent Motion ■ 1/4" Shaft ■ 60° Motion

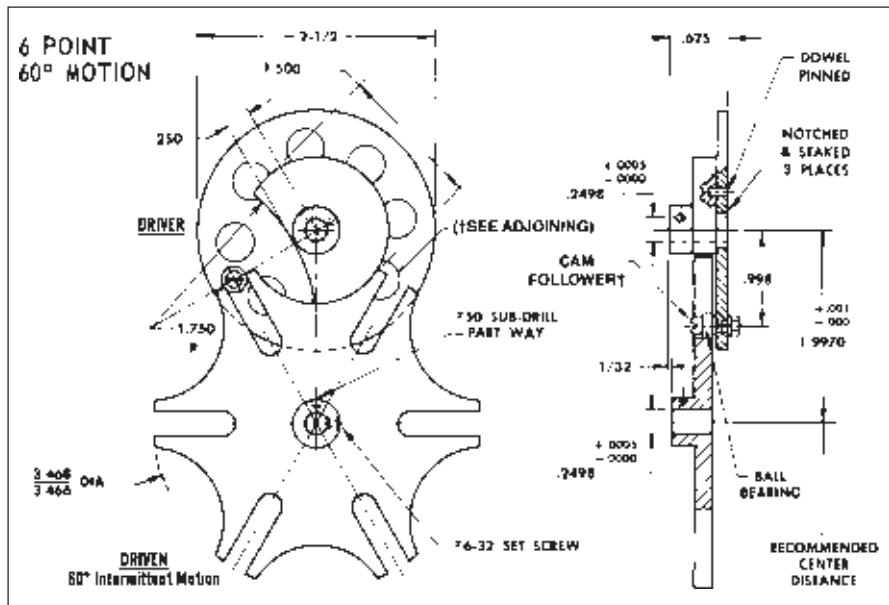

No. of Points	Intermittent Motion	Part No.
6	360° Driver = 60° Driven	EU-3

Driver Travel — Either Direction and Reversible
1/8" & 3/16" Shaft Units Available. Consult Factory.

*Lighting Holes
Optional, on Request

†2 Cam Followers
on Driver Available
on Request.

Material: 303 Stainless Steel

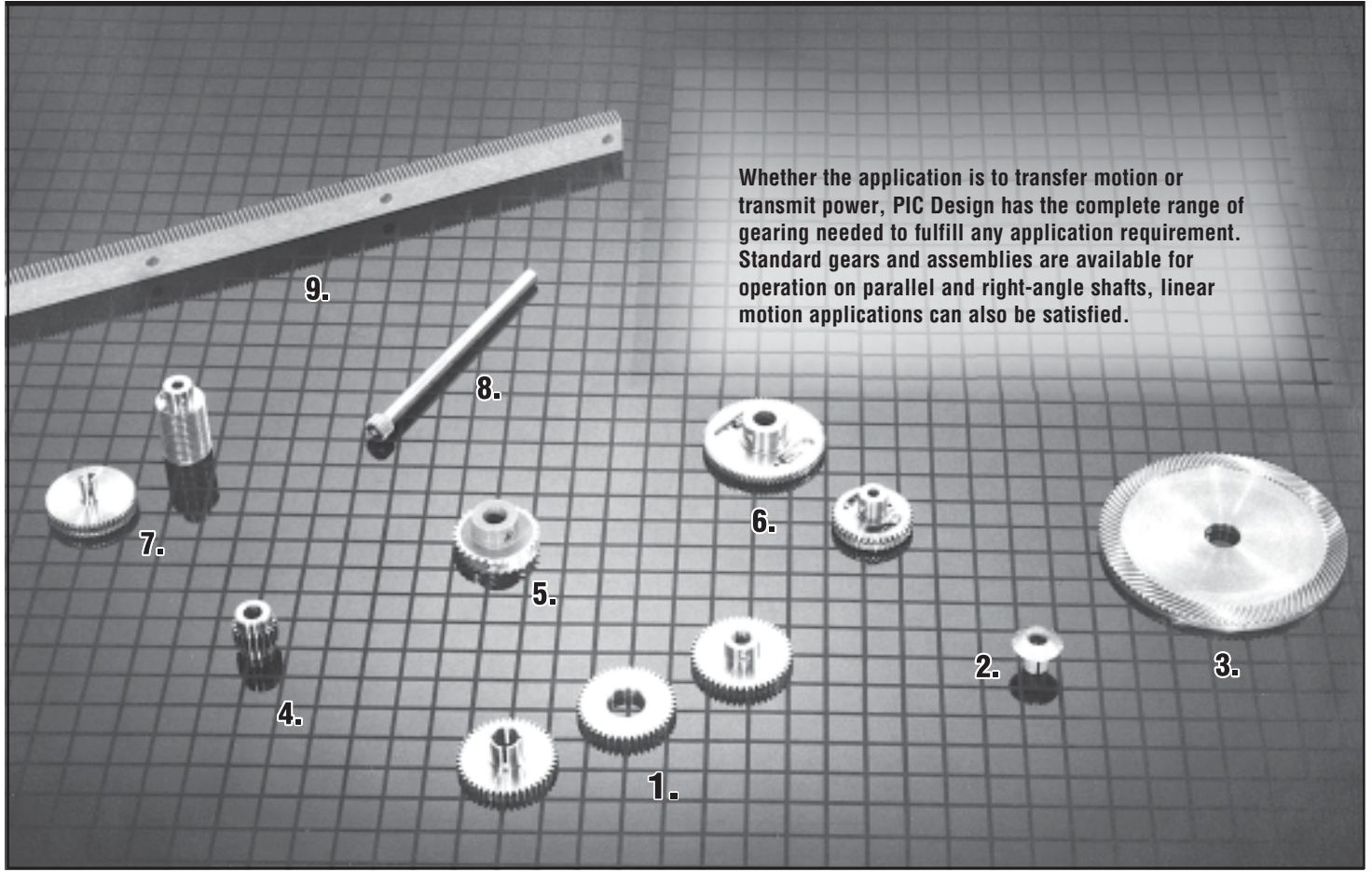

Whether the application is to transfer motion or transmit power, PIC Design has the complete range of gearing needed to fulfill any application requirement. Standard gears and assemblies are available for operation on parallel and right-angle shafts, linear motion applications can also be satisfied.

PIC Design Gears — A Brief Overview

1. **Spur Gears**
Designed and manufactured to mount on parallel shafts. Available in (inch) Diametral Pitch and (metric) Modules.
2. **Miter & Bevel Gears**
Designed and manufactured to operate on intersecting shafts positioned at a right angle.
3. **Spiral Gears**
Designed to operate at right angles with the pinion able to be mounted to mesh with any part of the 360° of the gear.
4. **Cluster Gears**
Spur gears manufactured to be mounted on a shaft and another gear to be mounted on the cluster for use in multiple gear ratios in a gear box.
5. **Helical Gears**
Designed with a 45° Helix angle to operate on parallel or right angle shafts.
6. **Anti-Backlash Gears**
Two independent gears mounted to same hub with a spring between the two providing a constant full-tooth engagement with the mating spur gear, thereby eliminating backlash in the mesh. Available in Spur, Worm and Miter Gears.
7. **Worm & Worm Wheels**
High ratios attainable in a single reduction with shafts at right angles to each other in limited space.
8. **Pinion Shafts**
Designed to be either supported by bearings or pressed into hollow shaft to operate with spur gear mounted on parallel shaft.
9. **Racks**
A gear with the teeth in a straight line, which produces linear motion when meshed with a circular spur gear.
10. For special gears including internal, sector, etc. Please consult factory

TECHNICAL SECTION

Tooth Proportions and Formulas for Spur Gears

	To Find:	English (Inches)	Metric (Millimeters)
Formulas	Circular Pitch (p)	$p = \frac{\pi D}{N} \text{ or } \frac{\pi d}{n}$	$p = \pi M \text{ or } \pi m$
	Pitch Diameter (Prin ⁿ (c))	$\frac{n}{P}$	nM
	Pitch Diameter (Gear (D))	$\frac{N}{P}$	NM
	Outside Diameter (Prin ⁿ (d))	$\frac{n+2}{P}$	$(n+2)M$
	Outside Diameter (Gear (D))	$\frac{N+2}{P}$	$(N+2)M$
	Center Distance (C)	$\frac{N+n}{2P}$	$\frac{N+n}{2}M$
Tooth Proportions	Addendum (a)	$\frac{1.000}{P}$	m
	Dedendum (b)	$\frac{1.200}{P} + 0.002 \text{ (min.)}$	$M + c = 1.16M$
	Working Depth (h ₁)	$\frac{2.000}{P}$	$2.000M$
	Whole Depth (h ₂)	$\frac{2.200}{P} + 0.002 \text{ (min.)}$	$2.16M$
	Clearance (c) (Standard)	$\frac{0.200}{P} + 0.002 \text{ (min.)}$	$1M \text{ to } 3M$ $1.16M \text{ typically}$
	Tooth Thickness (t) at Pitch Diameter	$t = \frac{1.5708}{P}$	$1 - \frac{nM}{2}$

The tooth proportions and formulas for Spur Gears for both inch (Diametral Pitch) and metric (Module) enable the designer or engineer to design the appropriate spur gear for a particular application.

Where P = Diametral Pitch
M = Module (Metric)
n = Number of Pinion Teeth
N = Number of Gear Teeth

Conversions

$$\text{Diametral Pitch (P)} = \frac{25.4}{M}$$

$$\text{Module (M)} = \frac{25.4}{P}$$

$$\text{Millimeters (mm)} = \frac{\text{Inches}}{0.03937} = 25.4 \text{ Inches}$$

$$\text{Inches} = 0.03937 \text{ mm} = \frac{\text{mm}}{25.4}$$

TOOTH-TO-TOOTH AND TOTAL COMPOSITE TOLERANCE

AGMA Standards for Inch, DIN Standards for Metric

The AGMA and DIN Fine-Pitch Gear Tolerances for inch and metric spur gears will assist the designer in selecting the AGMA or DIN quality level that will satisfy a particular application.

AGMA 390.03 FINE-PITCH GEAR TOLERANCES

PIC Quality Number	AGMA Quality Number	Number of Teeth and Pitch Diameter	Diametral Pitch Range	Tooth-to-Tooth Composite Tolerance	Total Composite Tolerance
S10	10*	Up to 20 Teeth incl	20 to 200	0.007	0.010
		Over 20 Teeth Up to 1.999"	20 to 200	0.005	0.010
		Over 20 Teeth 2" to 3.999"	20 to 200	0.005	0.012
		Over 20 Teeth 4" and over	20 to 200	0.005	0.014
-Q12	12**	Up to 20 Teeth incl	20 to 200	0.004	0.005
		Over 20 Teeth Up to 1.999"	20 to 200	0.003	0.005
		Over 20 Teeth 2" to 3.999"	20 to 200	0.003	0.006
		Over 20 Teeth 4" and over	20 to 200	0.003	0.007
-Q14	14***	Up to 20 Teeth incl	20 to 200	0.0019	0.0027
		Over 20 Teeth Up to 1.999"	20 to 200	0.0014	0.0027
		Over 20 Teeth 2" to 3.999"	20 to 200	0.0014	0.0037
		Over 20 Teeth 4" and over	20 to 200	0.0014	0.0037

* AGMA 390.03/PIC Q10 = AGMA/ANSI 2015-2-A06 C7/ISO T7

** AGMA 390.03/PIC Q12 = AGMA/ANSI 2015-2-A06 C6/ISO T6

*** AGMA 390.03/PIC Q14 = AGMA/ANSI 2015-2-A06 C5/ISO T5

AGMA 2015-2-A06 DIN FINE-PITCH GEAR TOLERANCES

PIC Quality Number	DIN Δ Quality Number	Pitch Diameter	Metric Module Range	Tooth-to-Tooth Composite Tolerance μm	Total Composite Tolerance μm
Std.	C7/T7	Up to 12mm	Up to 0.6 Module	7	20
		Over 12 to 50mm		9	25
		Over 50 to 100mm		10	28
		Over 100mm		11	32
T6	C6/T6	Up to 12mm	Over 0.6 Module	8	22
		Over 12 to 50mm		10	28
		Over 50 to 100mm		11	32
		Over 100mm		12	36
T5	C5/T5	Up to 12mm	Up to 0.6 Module	5	14
		Over 12 to 50mm		5.5	16
		Over 50 to 100mm		6	18
		Over 100mm		7	20
T5	C5/T5	Over 50 to 100mm	Over 0.6 Module	3.5	10
		Up to 12mm		4	11
		Over 12 to 50mm		4.5	12
		Over 50 to 100mm		5	14
T5	C5/T5	Up to 12mm	Over 0.6 Module	3.5	11
		Over 12 to 50mm		4.5	12
		Over 50 to 100mm		5	14
		Over 100mm		5	16

Δ DIN, ISO, ANSI

SPUR GEAR INDEX

INCH SPUR GEAR INDEX

Diametral Pitch	Face Width	Bore inches	Hub Style	Series Number	Page Number
16	3/16	1/4	Pin	16T	12-5
20	3/8	3/8	Pin	G77 & G78	12-6
1/10 th Cir. Pitch	3/16	1/4	Pin	G75	12-6
	1/4			G83	
24	1/8	1/4	Split	H23 & H24	12-7
		3/8	Hubless	J21 & J22	12-7
		1/4	Pin	24T	12-8
	3/16	3/16	Pin	G57 & G58	12-9
		1/4		G41 & G42	
	3/8	3/8	Pin	G79 & G80	12-9
32	1/8	3/16	Split	32HT	12-10
		1/4	Pin	32T	12-11
		1/4	Split	H25 & H26	12-12
		3/8	Hubless	J23 & J24	12-12
	3/16	3/16	Pin	G59 & G60	12-13
		1/4		G43 & G44	12-13
	3/8	3/8	Pin	G81 & G82	12-13
	48	1/8	1/8	Pin	G61 & G62
Split				H55 & H56	12-15
Pin				G1 & G2	12-14
3/16			Split	H57 & H58	12-15
			Pin	G3 & G4	12-14
1/4			Split	H1 & H2	12-15
3/16		3/8	Hubless	J1 & J2	12-15
		3/16	Pin	G5 & G6	12-16
		1/4		G7 & G8	

METRIC SPUR GEAR INDEX

Module	Face Width (MM)	Bore (MM)	Hub Style	Series Number	Page Number
.25	1.58	9.525	Hubless	MHS1 & MHS2	12-54
	2.38	3	Pin	MSG3 & MSG4	
	3.18		Split	MSG35 & MSG36	
.30	3.18	3	Pin	MSG5 & MSG6	12-55
			Split	MSG37 & MSG38	
		9.525	Hubless	MHS3 & MHS4	
.40	3.18	3	Pin	MSG7 & MSG8	12-56
		4	Pin	MSG9 & MSG10	12-56
			Split	MSG39 & MSG40	12-58
		6	Pin	MSG11 & MSG12	12-57
			Split	MSG41 & MSG42	12-58
		9.525	Hubless	MHS5 & MHS6	12-58
	4.76	6	Pin	MSG13 & MSG16	12-57
.50	3.18	3	Pin	MSG15 & MSG16	12-59
		4	Pin	MSG17 & MSG18	12-59
			Split	MSG43 & MSG44	12-61
		6	Pin	MSG19 & MSG20	12-60
			Split	MSG45 & MSG46	12-61
	9.525	Hubless	MHS7 & MHS8	12-61	
.60	4.76	6	Pin	MSG21 & MSG22	12-60
.70	4.76	6	Pin	MSG23 & MSG22	12-62
.80	3.18	6	Split	MSG25 & MSG26	12-63
		9.52	Hubless	MSG47 & MSG48	12-64
	6	Pin	MHS9 & MHS10		
	9.52	10	Pin	MSG27 & MSG28	12-65
1.0	3.18	6	Split	MSG29 & MSG30	12-65
		9.52	Hubless	MSG49 & MSG50	
	4.76	6	Pin	MHS11 & MHS12	
.80	4.76	6	Pin	MSG31 & MSG34	12-66
	9.52	10	Pin	MSG33 & MSG34	12-65

INCH SPUR GEAR INDEX

Diametral Pitch	Face Width	Bore inches	Hub Style	Series Number	Page Number	
64	1/8	1/8	Pin	G9 & G10	12-17	
		3/16		G11 & G12		
		1/4		G13 & G14		
		1/8	Split	H47 & H48	12-19	
		3/16		H3 & H4		
		1/4		H49 & H50		
	3/16	3/8	Hubless	J3 & J4	12-18	
		3/16	Pin	G15 & G16		
		1/4	Pin	G17 & G18		
		1/8	Pin	G19 & G20		
72	1/8	3/16	Split	G21 & G22	12-20	
		1/4		H5 & H6		
		3/16	3/8	Hubless	H59 & H60	12-21
			3/16	Pin	J5 & J6	
	80	1/8	3/16	Pin	G23 & G24	12-22
			1/4		G25 & G26	
1/8			Pin	G45 & G46	12-23	
3/16				G47 & G48		
96	1/16	1/8	Pin	80T	12-24	
		3/8		Hubless		J25 & J26
	3/32	1/8	Pin	G51 & G52	12-25	
		3/8		Hubless		J27 & J28
	1/8	1/8	Split	G27 & G28	12-25	
		1/8		H7 & H8		
		3/8	Hubless	J7 & J8	12-26	
	120	1/16	1/8	Pin	G55 & G56	12-27
3/32		G35 & G36				
1/8		3/8	Hubless	J9 & J10	12-27	

Odd Series: Stainless Steel
Even Series: Aluminum
 *Bronze instead of Aluminum

GEAR MATERIALS

Materials stated on the gear drawings are the commonly referred to designations (303, 2024-T4). This provides the designer with a ready reference for properties such as corrosion resistance, weight, yield and tensile strength. Detailed specifications are summarized in the following table.

Catalog Part Designation	Aluminum	Stainless Steel
Spur, Helical, Bevel & Worm CO. DN. F. G. H. J	2024-T4/T351 (Bar)	303 (Bar)
MHS, MSG, D12 4 6, 8, 10 12) Racks AG	2024-T4 (Bar)	416
Anti-backlash: P (2, 3, 4, 12 13 14, 22, 24 26) P (20 30, 40)	2024-T3 (Sheet) 2024-T4/T351 (Bar)	
P (5, 6 7 15, 16, 17, 21 23, 25) P (50, 60, 75)		303 (Sheet) 303 (Bar)

For Delrin, See Pages 12-31 through 12-34

SPUR GEAR-16 PITCH — $\frac{3}{16}$ " Face Width ■ 20° Pressure Angle

Pin Hub — $\frac{1}{4}$ " Bore

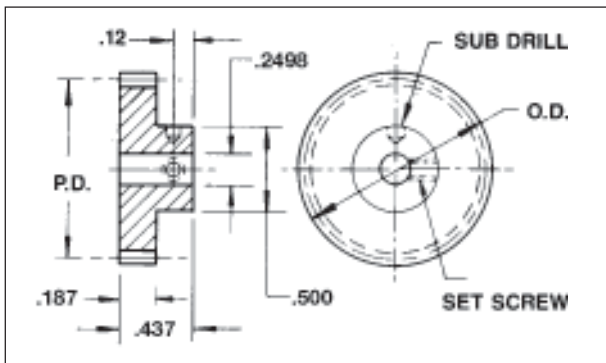

Material: 303 Stainless Steel
2024-T4 Aluminum
(Anodized Before Cutting)

Tolerances	Q10	Q12	Q14
Bore	+ .0005 - .0000	+ .0003 - .0000	+ .0002 - .0000
Pitch Diameter	+ .000 - .001	+ .0000 - .0007	+ .0000 - .0005
Outside Diameter	+ .000 - .002	+ .0000 - .0015	+ .000 - .001
Total Composite Tolerance	FOR AGMA QUALITY STANDARDS		
Tooth to Tooth Tolerance	SEE PAGE 12-2		

To order AGMA 12 Gears, add - Q12 to Part No.
To order AGMA 14 Gears, add - Q14 to Part No.

Gear Data			Stainless Steel	Aluminum
No. Teeth	P.D.	O.D.	Part No.	Part No.
11	0.6875	0.813	16T11S	16T11A
12	0.7500	0.875	16T12S	16T12A
13	0.8125	0.938	16T13S	16T13A
14	0.8750	1.000	16T14S	16T14A
15	0.9375	1.063	16T15S	16T15A
16	1.0000	1.125	16T16S	16T16A
17	1.0625	1.188	16T17S	16T17A
18	1.1250	1.250	16T18S	16T18A
19	1.1875	1.313	16T19S	16T19A
20	1.2500	1.375	16T20S	16T20A
21	1.3125	1.438	16T21S	16T21A
22	1.3750	1.500	16T22S	16T22A
23	1.4375	1.563	16T23S	16T23A
24	1.5000	1.625	16T24S	16T24A
27	1.6875	1.813	16T27S	16T27A
30	1.8750	2.000	16T30S	16T30A
32	2.0000	2.125	16T32S	16T32A
34	2.1250	2.250	16T34S	16T34A
38	2.3750	2.500	16T38S	16T38A
40	2.5000	2.625	16T40S	16T40A
44	2.7500	2.875	16T44S	16T44A
46	2.8750	3.000	16T46S	16T46A
48	3.0000	3.125	16T48S	16T48A
52	3.2500	3.375	16T52S	16T52A
54	3.3750	3.500	16T54S	16T54A
56	3.5000	3.625	16T56S	16T56A
58	3.6250	3.750	16T58S	16T58A
60	3.7500	3.875	16T60S	16T60A
62	3.8750	4.000	16T62S	16T62A
64	4.0000	4.125	16T64S	16T64A
65	4.0625	4.188	16T65S	16T65A

For gears with a number of teeth not shown within the range listed above, substitute the required number of teeth for the digits at the end of the Part Number.

Pricing can be determined by using our online E-Commerce price list for the next higher published part number in the listing.

SPUR GEAR-20 PITCH — 3/8" Face Width ■ 20° Pressure Angle

Pin Hub — 3/8" Bore

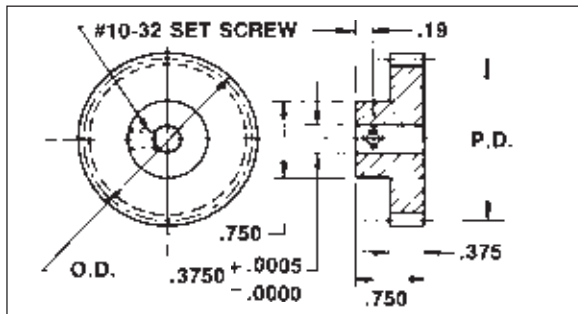

For gears with a number of teeth not shown within the range listed above, substitute the required number of teeth for the digits at the end of the Part Number.

Pricing can be determined by using our online E-Commerce price list for the next higher published part number in the listing.

AGMA Quality Number 10-C	Tooth-to-Tooth Composite	Total Composite
Up to 20 Teeth Inclusive	.0007	.0010
Over 20 Teeth—up to 1.999" P.D.	.0005	.0010
Over 20 Teeth—2" to 2.999" P.D.	.0005	.0012
Over 20 Teeth—4" P.D. and over	.0005	.0014

"C"—BACKLASH DESIGNATION.

Provides .0005 to .001 tooth thinning at pitch line. Allows operation on theoretical centers.

Gear Data			#303 STAINLESS STEEL	BRONZE Alloy 484
No. Teeth	P.D.	O.D.	Part No.	Part No.
18	.9000	1.000	G77-18	G78-18
20	1.0000	1.100	G77-20	G78-20
24	1.2000	1.300	G77-24	G78-24
28	1.4000	1.500	G77-28	G78-28
30	1.5000	1.600	G77-30	G78-30
36	1.8000	1.900	G77-36	G78-36
40	2.0000	2.100	G77-40	G78-40
48	2.4000	2.500	G77-48	G78-48
56	2.8000	2.900	G77-56	G78-56
60	3.0000	3.100	G77-60	G78-60
72	3.6000	3.700	G77-72	G78-72
80	4.0000	4.100	G77-80	G78-80
84	4.2000	4.300	G77-84	G78-84
96	4.8000	4.900	G77-96	G78-96
100	5.0000	5.100	G77-100	G78-100

SPUR GEAR 1/10th CIR. PITCH — 3/16" Face Width ■ 20° Pressure Angle

Pin Hub — 1/4" Bore

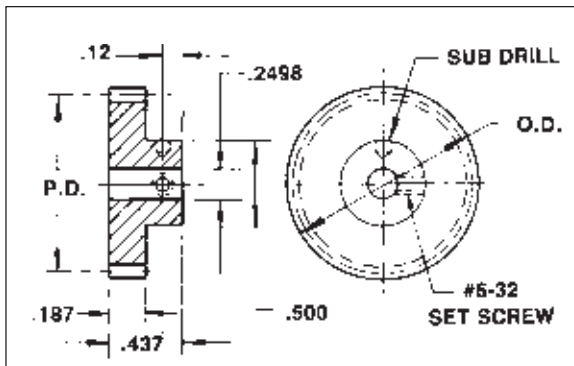

Tolerances	Q10	Q12	Q14
Bore	+ .0005 - .0000	+ .0003 - .0000	+ .0002 - .0000
Pitch Diameter	+ .000 - .001	+ .0000 - .0007	+ .0000 - .0005
Outside Diameter	+ .000 - .002	+ .0000 - .0015	+ .000 - .001
Total Composite Tolerance	FOR AGMA QUALITY STANDARDS SEE PAGE 12-2		
Tooth to Tooth Tolerance	FOR AGMA QUALITY STANDARDS SEE PAGE 12-2		

No. Teeth	P.D.	O.D.	Part No.
20	.6366	.700	G75-20
40	1.2732	1.337	G75-40

To order AGMA 13 Gears, add Q13 to Cat. No

Material: 303 Stainless Steel

SPUR GEAR 1/10th CIR. PITCH — 1/4" Face Width ■ 20° Pressure Angle

AGMA Quality No. 13 ■ Pin Hub — 1/4" Bore

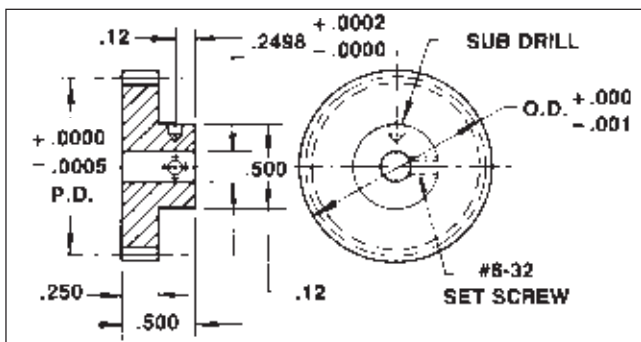

AGMA Quality No. 13	Tooth-to-Tooth Composite	Total Composite
20 Teeth	.0003	.0004
40 Teeth	.0002	.0004

No. Teeth	P.D.	O.D.	Part No.
20	.6366	.700	G83-20
40	1.2732	1.337	G83-40

Material: Stainless Steel 17-4PH
Heat Treated to RC42 Minimum

SPUR GEAR-24 PITCH — 1/8" Face Width ■ 20° Pressure Angle

Split Hub - 1/4" Bores — Hubless 3/8" Bore

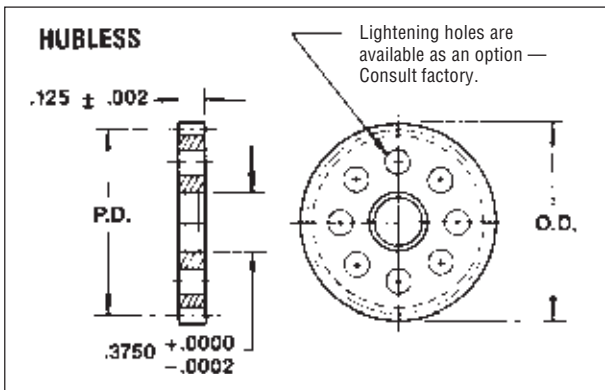
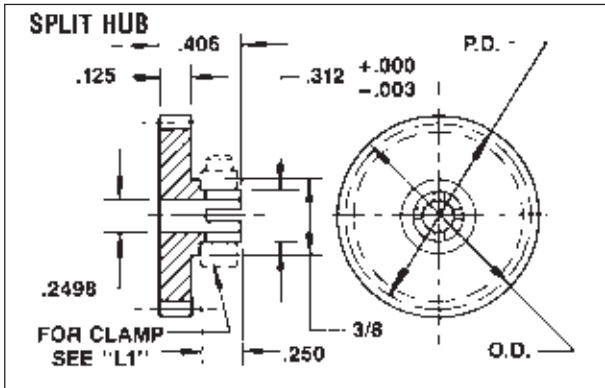

Material: 303 Stainless Steel
2024-T4 Aluminum
(Anodized Before Cutting)

No. Teeth	Gear Data		Stainless Steel Part No.		Aluminum Part No.	
	P.D.	O.D.	Split Hub	Hubless	Split Hub	Hubless
12	.5000	.583	H23-12	—	H24-12	—
13	.5418	.625	H23-13	—	H24-13	—
14	.5833	.667	H23-14	—	H24-14	—
15	.6250	.708	H23-15	J21-15	H24-15	J22-15
16	.6667	.750	H23-16	J21-16	H24-16	J22-16
17	.7083	.792	H23-17	J21-17	H24-17	J22-17
18	.7500	.833	H23-18	J21-18	H24-18	J22-18
19	.7917	.875	H23-19	J21-19	H24-19	J22-19
20	.8333	.917	H23-20	J21-20	H24-20	J22-20
21	.8750	.958	H23-21	J21-21	H24-21	J22-21
22	.9167	1.000	H23-22	J21-22	H24-22	J22-22
23	.9583	1.042	H23-23	J21-23	H24-23	J22-23
24	1.0000	1.083	H23-24	J21-24	H24-24	J22-24
27	1.1250	1.208	H23-27	J21-27	H24-27	J22-27
30	1.2500	1.333	H23-30	J21-30	H24-30	J22-30
33	1.3750	1.458	H23-33	J21-33	H24-33	J22-33
36	1.5000	1.583	H23-36	J21-36	H24-36	J22-36
39	1.6250	1.708	H23-39	J21-39	H24-39	J22-39
42	1.7500	1.833	H23-42	J21-42	H24-42	J22-42
45	1.8750	1.958	H23-45	J21-45	H24-45	J22-45
48	2.0000	2.083	H23-48	J21-48	H24-48	J22-48
51	2.1250	2.208	H23-51	J21-51	H24-51	J22-51
54	2.2500	2.333	H23-54	J21-54	H24-54	J22-54
57	2.3750	2.458	H23-57	J21-57	H24-57	J22-57
60	2.5000	2.583	H23-60	J21-60	H24-60	J22-60
72	3.000	3.083	—	J21-72	—	J22-72
78	3.2500	3.333	—	J21-78	—	J22-78
84	3.5000	3.583	—	J21-84	—	J22-84
90	3.7500	3.833	—	J21-90	—	J22-90
96	4.0000	4.083	—	J21-96	—	J22-96
99	4.1250	4.208	—	J21-99	—	J22-99

Other Size Bores Available. Consult Factory

For Gear Hubs See Pages 12-67 & 12-68

Tolerances	Q10	Q12	Q14
Bore	+ .0005 - .0000	+ .0003 - .0000	+ .0002 - .0000
Pitch Diameter	+ .000 - .001	+ .0000 - .0007	+ .0000 - .0005
Outside Diameter	+ .000 - .002	+ .0000 - .0015	+ .000 - .001
Total Composite Tolerance	FOR AGMA QUALITY STANDARDS		
Tooth to Tooth Tolerance	SEE PAGE 12-2		

To order AGMA 12 Gears, add — Q12 to Part No
To order AGMA 14 Gears, add — Q14 to Part No

For gears with a number of teeth not shown within the range listed above, substitute the required number of teeth for the digits at the end of the Part Number.

Pricing can be determined by using our online E-Commerce price list for the next higher published part number in the listing.

SPUR GEAR-24 PITCH — 1/8" Face Width ■ 20° Pressure Angle

Pin Hub — 1/4" Bore

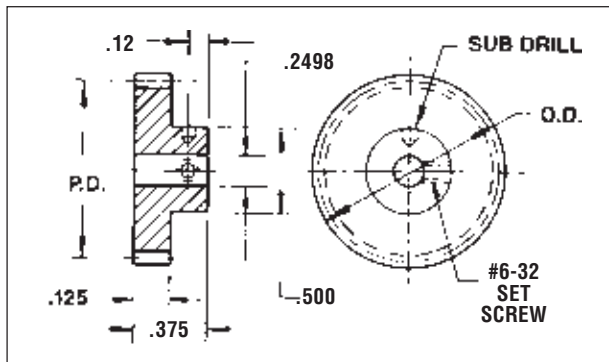

Material: 303 Stainless Steel
2024-T4 Aluminum
(Anodized Before Cutting)

Tolerances	Q11	Q12	Q14
Bore	+ .0005 - .0000	+ .0003 - .0000	+ .0002 - .0000
Pitch Diameter	+ .000 - .001	+ .0000 - .0007	+ .0000 - .0005
Outside Diameter	+ .000 - .002	+ .0000 - .0015	+ .000 - .001
Total Composite Tolerance	FOR AGMA QUALITY STANDARDS SEE PAGF 12-2		
Tooth to Tooth Tolerance			

To order AGMA 12 Gears, add - Q12 to Part No
To order AGMA 14 Gears, add - Q14 to Part No

For gears with a number of teeth not shown within the range listed above, substitute the required number of teeth for the digits at the end of the Part Number.

Pricing can be determined by using our online E-Commerce price list for the next higher published part number in the listing.

Gear Data			Stainless Steel	Aluminum
No. Teeth	P.D.	O.D.	Part No.	Part No.
*12	0.5000	0.583	24T12S	24T12A
*13	0.5417	0.625	24T13S	24T13A
*14	0.5833	0.667	24T14S	24T14A
*15	0.6250	0.708	24T15S	24T15A
16	0.6667	0.750	24T16S	24T16A
17	0.7083	0.792	24T17S	24T17A
18	0.7500	0.833	24T18S	24T18A
19	0.7917	0.875	24T19S	24T19A
20	0.8333	0.917	24T20S	24T20A
21	0.8750	0.958	24T21S	24T21A
22	0.9167	1.000	24T22S	24T22A
23	0.9583	1.042	24T23S	24T23A
24	1.0000	1.083	24T24S	24T24A
25	1.0417	1.125	24T25S	24T25A
30	1.2500	1.333	24T30S	24T30A
33	1.3750	1.458	24T33S	24T33A
36	1.5000	1.583	24T36S	24T36A
39	1.6250	1.708	24T39S	24T39A
42	1.7500	1.833	24T42S	24T42A
45	1.8750	1.958	24T45S	24T45A
48	2.0000	2.083	24T48S	24T48A
51	2.1250	2.208	24T51S	24T51A
54	2.2500	2.333	24T54S	24T54A
57	2.3750	2.458	24T57S	24T57A
60	2.5000	2.583	24T60S	24T60A
63	2.6250	2.708	24T63S	24T63A
66	2.7500	2.833	24T66S	24T66A
69	2.8750	2.958	24T69S	24T69A
72	3.0000	3.083	24T72S	24T72A
78	3.2500	3.333	24T78S	24T78A
84	3.5000	3.583	24T84S	24T84A
90	3.7500	3.833	24T90S	24T90A
96	4.0000	4.083	24T96S	24T96A
99	4.1250	4.208	24T99S	24T99A

Other Size Bores Available, Consult Factory
* Hob cuts into Hub

SPUR GEAR-24 PITCH — 3/16" Face Width ■ 20° Pressure Angle

Pin Hub — 3/16", 1/4" Bores

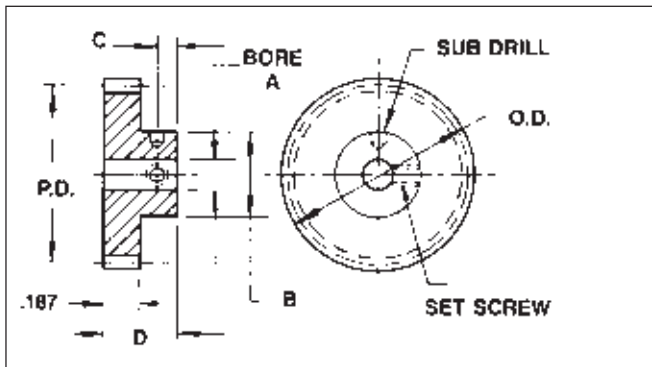

Material: 303 Stainless Steel
2024-T4 Aluminum
(Anodized Before Cutting)

Dimen.	Bore	
	3/16	1/4
A	1873	2498
B	.375	.500
C	.11	.12
D	.406	.437
Set Screw	#4-40	#6-32

Tolerances	Q10	Q12	Q14
Bore	+ .0005 - .0000	+ .0003 - .0000	+ .0002 - .0000
Pitch Diameter	+ .000 - .001	+ .0000 - .0007	+ .0000 - .0005
Outside Diameter	+ .000 - .002	+ .0000 - .0015	+ .000 - .001
Total Composite Tolerance	FOR AGMA QUALITY STANDARDS SEE PAGE 12-2		
Tooth to Tooth Tolerance	FOR AGMA QUALITY STANDARDS SEE PAGE 12-2		

To order AGMA 12 Gears, add - Q12 to Part No.
To order AGMA 14 Gears, add - Q14 to Part No.

For gears with a number of teeth not shown within the range listed above, substitute the required number of teeth for the digits at the end of the Part Number.

Pricing can be determined by using our online E-Commerce price list for the next higher published part number in the listing.

Gear Data			Stainless Steel Part No. Bore Size		Aluminum Part No. Bore Size	
No. Teeth	P.D.	O.D.	.1873	.2498	.1873	.2498
12	5000	583	G57-12	—	G58-12	—
13	5418	626	G57-13	—	G58-13	—
14	5833	667	G57-14	—	G58-14	—
15	6250	708	G57-15	G41-15	G58-15	G42-15
16	6667	750	G57-16	G41-16	G58-16	G42-16
18	7500	833	G57-18	G41-18	G58-18	G42-18
20	8333	917	G57-20	G41-20	G58-20	G42-20
22	9167	1000	G57-22	G41-22	G58-22	G42-22
24	10000	1083	G57-24	G41-24	G58-24	G42-24
27	1250	1208	G57-27	G41-27	G58-27	G42-27
30	2500	1333	G57-30	G41-30	G58-30	G42-30
36	3000	1583	G57-36	G41-36	G58-36	G42-36
39	16250	1708	G57-39	G41-39	G58-39	G42-39
42	17500	1833	G57-42	G41-42	G58-42	G42-42
45	18750	1958	G57-45	G41-45	G58-45	G42-45
48	20000	2083	G57-48	G41-48	G58-48	G42-48
54	22500	2333	G57-54	G41-54	G58-54	G42-54
60	25000	2583	G57-60	G41-60	G58-60	G42-60
63	26250	2708	G57-63	G41-63	G58-63	G42-63
66	27500	2833	G57-66	G41-66	G58-66	G42-66
69	28750	2958	G57-69	G41-69	G58-69	G42-69
72	30000	3083	G57-72	G41-72	G58-72	G42-72
75	31250	3208	G57-75	G41-75	G58-75	G42-75
78	32500	3333	—	G41-78	—	G42-78
81	33750	3458	—	G41-81	—	G42-81
84	35000	3583	—	G41-84	—	G42-84
87	36250	3708	—	G41-87	—	G42-87
90	37500	3833	—	G41-90	—	G42-90
93	38750	3958	—	G41-93	—	G42-93
96	40000	4083	—	G41-96	—	G42-96
99	41250	4208	—	G41-99	—	G42-99

Other Size Bores Available. Consult Factory

SPUR GEAR-24 PITCH — 3/8" Face Width ■ 20° Pressure Angle

Pin Hub — 3/8" Bore

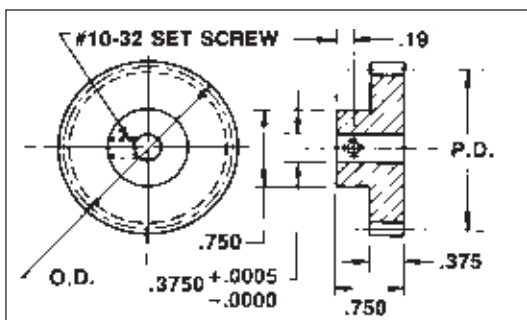

For gears with a number of teeth not shown within the range listed above, substitute the required number of teeth for the digits at the end of the Part Number.

Pricing can be determined by using our online E-Commerce price list for the next higher published part number in the listing.

TOLERANCES

AGMA Quality Number 10-C	Tooth-to-Tooth Composite	Total Composite
Up to 20 Teeth Inclusive	.0007	.0010
Over 20 Teeth—up to 1.999" P.D.	.0005	.0010
Over 20 Teeth—2" to 2.999" P.D.	.0005	.0012
Over 20 Teeth—4" P.D. and over	.0005	.0014

"C" BACKLASH DESIGNATION.

Provides .0005 to .001 tooth thinning at pitch line. Allows operation on theoretical centers.

Gear Data			#303 STAINLESS STEEL	BRONZE Alloy 484
No. Teeth	P.D.	O.D.	Part No.	Part No.
24	1.0000	1.083	G79-24	G80-24
28	1.1667	1.250	G79-28	G80-28
30	1.2500	1.333	G79-30	G80-30
36	1.5000	1.583	G79-36	G80-36
40	1.6667	1.750	G79-40	G80-40
48	2.0000	2.083	G79-48	G80-48
56	2.3333	2.417	G79-56	G80-56
60	2.5000	2.583	G79-60	G80-60
72	3.0000	3.083	G79-72	G80-72
80	3.3333	3.417	G79-80	G80-80
96	4.0000	4.083	G79-96	G80-96
112	4.6667	4.750	G79-112	G80-112
120	5.0000	5.083	G79-120	G80-120

www.pic-design.com

Interactive catalog ■ CAD ■ e-commerce

PIC DESIGN

Phone: 800-243-6125 ■ FAX: 203-758-8271

E-Mail: sales@pic-design.com

12-9

SPUR GEAR-32 PITCH — 1/8" Face Width ■ 20° Pressure Angle

Split Hub - 3/16" Bore

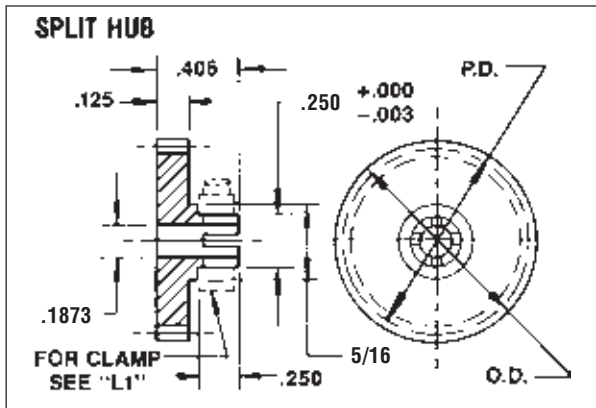

Material: 303 Stainless Steel
2024-T4 Aluminum
(Anodized Before Cutting)

Tolerances	Q10	Q12	Q14
Bore	+ .0005 - .0000	+ .0003 - .0000	+ .0002 - .0000
Pitch Diameter	+ .000 - .001	+ .0000 - .0007	+ .0000 - .0005
Outside Diameter	+ .000 - .002	+ .0000 - .0015	+ .000 - .001
Total Composite Tolerance	FOR AGMA QUALITY STANDARDS		
Tooth to Tooth Tolerance	SEE PAGE 12-2		

To order AGMA 12 Gears, add - Q12 to Part No
To order AGMA 14 Gears, add - Q14 to Part No

For gears with a number of teeth not shown within the range listed above, substitute the required number of teeth for the digits at the end of the Part Number.

Pricing can be determined by using our online E-Commerce price list for the next higher published part number in the listing.

Gear Data			Stainless Steel	Aluminum
No. Teeth	P.D.	O.D.	Part No.	Part No.
14	0.4375	0.500	32HT14S	32HT14A
15	0.4688	0.531	32HT15S	32HT15A
16	0.5000	0.563	32HT16S	32HT16A
17	0.5313	0.594	32HT17S	32HT17A
18	0.5625	0.625	32HT18S	32HT18A
19	0.5938	0.656	32HT19S	32HT19A
20	0.6250	0.688	32HT20S	32HT20A
21	0.6563	0.719	32HT21S	32HT21A
22	0.6875	0.750	32HT22S	32HT22A
23	0.7188	0.781	32HT23S	32HT23A
24	0.7500	0.813	32HT24S	32HT24A
25	0.7813	0.844	32HT25S	32HT25A
28	0.8750	0.938	32HT28S	32HT28A
30	0.9375	1.000	32HT30S	32HT30A
32	1.0000	1.063	32HT32S	32HT32A
33	1.0313	1.094	32HT33S	32HT33A
36	1.1250	1.188	32HT36S	32HT36A
39	1.2188	1.281	32HT39S	32HT39A
40	1.2500	1.313	32HT40S	32HT40A
42	1.3125	1.375	32HT42S	32HT42A
45	1.4063	1.469	32HT45S	32HT45A
48	1.5000	1.563	32HT48S	32HT48A
51	1.5938	1.656	32HT51S	32HT51A
54	1.6875	1.750	32HT54S	32HT54A
56	1.7500	1.813	32HT56S	32HT56A
60	1.8750	1.938	32HT60S	32HT60A
63	1.9688	2.031	32HT63S	32HT63A
64	2.0000	2.063	32HT64S	32HT64A
66	2.0625	2.125	32HT66S	32HT66A
69	2.1563	2.219	32HT69S	32HT69A
72	2.2500	2.313	32HT72S	32HT72A
78	2.4375	2.500	32HT78S	32HT78A
80	2.5000	2.563	32HT80S	32HT80A
84	2.6250	2.688	32HT84S	32HT84A
90	2.8125	2.875	32HT90S	32HT90A
96	3.0000	3.063	32HT96S	32HT96A
99	3.0938	3.156	32HT99S	32HT99A
112	3.5000	3.563	32HT112S	32HT112A
125	3.9063	3.969	32HT125S	32HT125A
128	4.0000	4.063	32HT128S	32HT128A
130	4.0625	4.125	32HT130S	32HT130A
132	4.1250	4.188	32HT132S	32HT132A

Other Bore Sizes Available. Consult Factory.

For Gear Hubs See Pages 12-67 & 12-68

SPUR GEAR-32 PITCH — 1/8" Face Width ■ 20° Pressure Angle

Pin Hub - 1/4" Bore

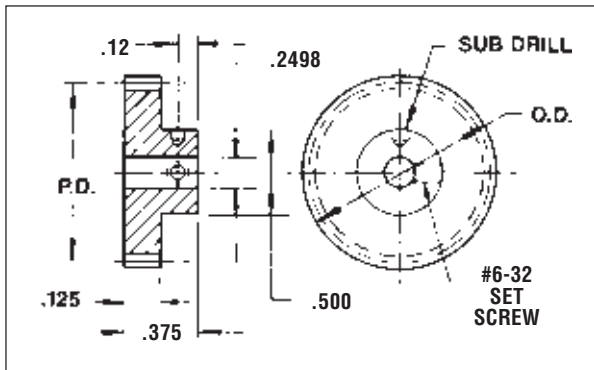

Material: 303 Stainless Steel
2024-T4 Aluminum
(Anodized Before Cutting)

Tolerances	Q10	Q12	Q14
Bore	+ .0005 - .0000	+ .0003 - .0000	+ .0002 - .0000
Pinch Diameter	+ .000 - .001	+ .0000 - .0007	+ .0000 - .0005
Outside Diameter	+ .000 - .002	+ .0000 - .0015	+ .000 - .001
Total Composite Tolerance	FOR AGMA QUALITY STANDARDS		
Teeth to Teeth Tolerance	SEE PAGE 12-2		

To order AGMA 12 Gears, add - Q12 to Part No
To order AGMA 14 Gears, add - Q14 to Part No

For gears with a number of teeth not shown within the range listed above, substitute the required number of teeth for the digits at the end of the Part Number.

Pricing can be determined by using our online E-Commerce price list for the next higher published part number in the listing.

Gear Data			Stainless Steel	Aluminum
No. Teeth	P.D.	O.D.	Part No.	Part No.
14*	0.4375	0.500	32T14S	32T14A
15*	0.4688	0.531	32T15S	32T15A
16*	0.5000	0.563	32T16S	32T16A
17*	0.5313	0.594	32T17S	32T17A
18*	0.5625	0.625	32T18S	32T18A
19*	0.5938	0.656	32T19S	32T19A
20	0.6250	0.688	32T20S	32T20A
21	0.6563	0.719	32T21S	32T21A
22	0.6875	0.750	32T22S	32T22A
23	0.7188	0.781	32T23S	32T23A
24	0.7500	0.813	32T24S	32T24A
25	0.7813	0.844	32T25S	32T25A
28	0.8750	0.938	32T28S	32T28A
30	0.9375	1.000	32T30S	32T30A
32	1.0000	1.063	32T32S	32T32A
33	1.0313	1.094	32T33S	32T33A
36	1.1250	1.188	32T36S	32T36A
39	1.2188	1.281	32T39S	32T39A
40	1.2500	1.313	32T40S	32T40A
42	1.3125	1.375	32T42S	32T42A
45	1.4063	1.469	32T45S	32T45A
48	1.5000	1.563	32T48S	32T48A
51	1.5938	1.656	32T51S	32T51A
54	1.6875	1.750	32T54S	32T54A
56	1.7500	1.813	32T56S	32T56A
60	1.8750	1.938	32T60S	32T60A
63	1.9688	2.031	32T63S	32T63A
64	2.0000	2.063	32T64S	32T64A
66	2.0625	2.125	32T66S	32T66A
69	2.1563	2.219	32T69S	32T69A
72	2.2500	2.313	32T72S	32T72A
78	2.4375	2.500	32T78S	32T78A
80	2.5000	2.563	32T80S	32T80A
84	2.6250	2.688	32T84S	32T84A
90	2.8125	2.875	32T90S	32T90A
96	3.0000	3.063	32T96S	32T96A
99	3.0938	3.156	32T99S	32T99A
112	3.5000	3.563	32T112S	32T112A
125	3.9063	3.969	32T125S	32T125A
128	4.0000	4.063	32T128S	32T128A
130	4.0625	4.125	32T130S	32T130A
132	4.1250	4.188	32T132S	32T132A

Other Bore Sizes Available. Consult Factory.

*Hob cuts into hub. Hub O.D. never exceeds gear O.D.

SPUR GEAR-32 PITCH — 1/8" Face Width ■ 20° Pressure Angle

Split Hub - 1/4" Bores — Hubless 3/8" Bore

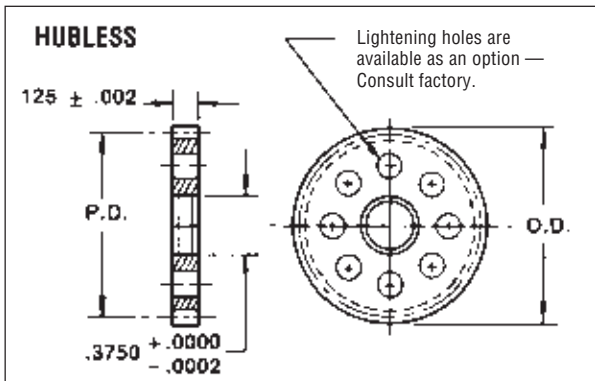
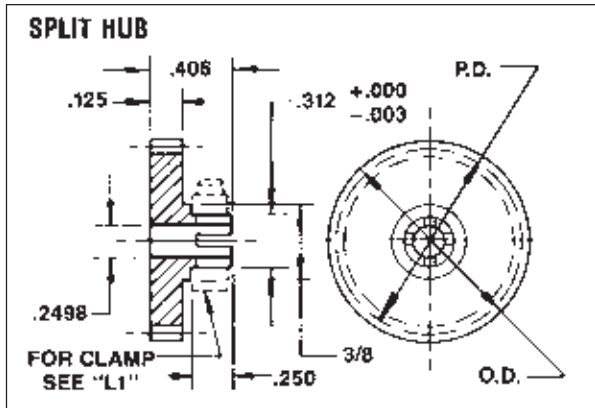

Material: 303 Stainless Steel
2024-T4 Aluminum
(Anodized Before Cutting)

Tolerances	Q10	Q12	Q14
Bore	+ .0005 - .0000	+ .0003 - .0000	+ .0002 - .0000
Pitch Diameter	+ .000 - .001	+ .0000 - .0007	+ .0000 - .0005
Outside Diameter	+ .000 - .002	+ .0000 - .0015	+ .000 - .001
Total Composite Tolerance	FOR AGMA QUALITY STANDARDS		
Tooth to Tooth Tolerance	SEE PAGE 12-2		

To order AGMA 12 Gears, add - Q12 to Part No.
To order AGMA 14 Gears, add - Q14 to Part No.

For gears with a number of teeth not shown within the range listed above, substitute the required number of teeth for the digits at the end of the Part Number.

Pricing can be determined by using our online E-Commerce price list for the next higher published part number in the listing.

No. Teeth	Gear Data		Stainless Steel Part No.		Aluminum Part No.	
	P.D.	O.D.	Split Hub	Hubless	Split Hub	Hubless
15	.4688	.531	H25-15	—	H26-15	—
16	.5000	.563	H25-16	—	H26-16	—
17	.5313	.594	H25-17	—	H26-17	—
18	.5625	.625	H25-18	—	H26-18	—
19	.5938	.656	H25-19	J23-19	H26-19	J24-19
20	.6250	.688	H25-20	J23-20	H26-20	J24-20
22	.6875	.750	H25-22	J23-22	H26-22	J24-22
24	.7500	.813	H25-24	J23-24	H26-24	J24-24
26	.8125	.875	H25-26	J23-26	H26-26	J24-26
28	.8750	.938	H25-28	J23-28	H26-28	J24-28
30	.9375	1.000	H25-30	J23-30	H26-30	J24-30
32	1.0000	1.063	H25-32	J23-32	H26-32	J24-32
36	1.1250	1.188	H25-36	J23-36	H26-36	J24-36
40	1.2500	1.313	H25-40	J23-40	H26-40	J24-40
48	1.5000	1.563	H25-48	J23-48	H26-48	J24-48
56	1.7500	1.813	H25-56	J23-56	H26-56	J24-56
64	2.0000	2.063	H25-64	J23-64	H26-64	J24-64
72	2.2500	2.313	H25-72	J23-72	H26-72	J24-72
80	2.5000	2.563	H25-80	J23-80	H26-80	J24-80
88	2.7500	2.813	H25-88	J23-88	H26-88	J24-88
96	3.0000	3.063	H25-96	J23-96	H26-96	J24-96
112	3.5000	3.563	H25-112	J23-112	H26-112	J24-112
127	3.9688	4.031	H25-127	J23-127	H26-127	J24-127
128	4.0000	4.063	H25-128	J23-128	H26-128	J24-128
132	4.1250	4.188	H25-132	J23-132	H26-132	J24-132

Other Size Bores Available. Consult Factory

For Gear Hubs See Pages 12-67 & 12-68

SPUR GEAR-32 PITCH — 3/16" Face Width ■ 20° Pressure Angle

Pin Hub — 3/16", 1/4" Bores

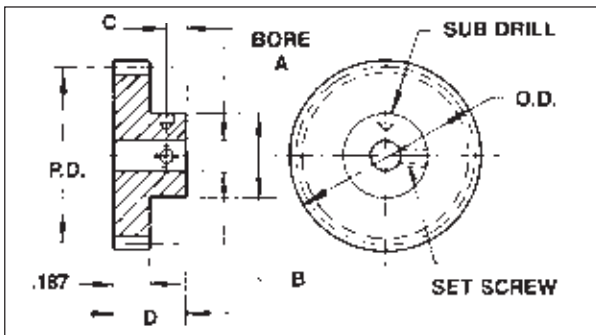

Material: 303 Stainless Steel
2024-T4 Aluminum
(Anodized Before Cutting)

Dimen.	Bore	
	3/16	1/4
A	.1873	.2498
B	.375	.500
C	.11	.12
D	.406	.437
Set Screw	#4-40	#6-32

Tolerances	Q10	Q12	Q14
Bore	+ .0005 - .0000	+ .0003 - .0000	+ .0002 - .0000
Pitch Diameter	+ .000 - .001	+ .0000 - .0007	+ .0000 - .0005
Outside Diameter	+ .000 - .002	+ .0000 - .0015	+ .000 - .001
Total Composite Tolerance	FOR AGMA QUALITY STANDARDS SEE PAGE 12-2		
Tooth to Tooth Tolerance	FOR AGMA QUALITY STANDARDS SEE PAGE 12-2		

To order AGMA 12 Gears, add - Q12 to Part No.
To order AGMA 14 Gears, add - Q14 to Part No.

For gears with a number of teeth not shown within the range listed above, substitute the required number of teeth for the digits at the end of the Part Number.

Pricing can be determined by using our online E-Commerce price list for the next higher published part number in the listing.

Gear Data			Stainless Steel Part No. Bore Size		Aluminum Part No. Bore Size	
No. Teeth	P.D.	O.D.	.1873	.2498	.1873	.2498
15	.4688	.531	G59-15	—	G60-15	—
16	.5000	.563	G59-16	—	G60-16	—
17	.5313	.594	G59-17	—	G60-17	—
18	.5625	.625	G59-18	—	G60-18	—
20	.6250	.688	G59-20	—	G60-20	—
22	.6875	.750	G59-22	G43-22	G60-22	G44-22
24	.7500	.813	G59-24	G43-24	G60-24	G44-24
26	.8125	.875	G59-26	G43-26	G60-26	G44-26
28	.8750	.938	G59-28	G43-28	G60-28	G44-28
30	.9375	1.000	G59-30	G43-30	G60-30	G44-30
32	1.0000	1.063	G59-32	G43-32	G60-32	G44-32
34	1.0625	1.125	G59-34	G43-34	G60-34	G44-34
36	1.1250	1.188	G59-36	G43-36	G60-36	G44-36
38	1.1875	1.250	G59-38	G43-38	G60-38	G44-38
40	1.2500	1.313	G59-40	G43-40	G60-40	G44-40
44	1.3750	1.438	G59-44	G43-44	G60-44	G44-44
48	1.5000	1.563	G59-48	G43-48	G60-48	G44-48
52	1.6250	1.688	G59-52	G43-52	G60-52	G44-52
56	1.7500	1.813	G59-56	G43-56	G60-56	G44-56
60	1.8750	1.938	G59-60	G43-60	G60-60	G44-60
64	2.0000	2.063	G59-64	G43-64	G60-64	G44-64
68	2.1250	2.188	G59-68	G43-68	G60-68	G44-68
72	2.2500	2.313	G59-72	G43-72	G60-72	G44-72
80	2.5000	2.563	G59-80	G43-80	G60-80	G44-80
82	2.6250	2.688	G59-84	G43-84	G60-84	G44-84
88	2.7500	2.813	G59-88	G43-88	G60-88	G44-88
92	2.8750	2.938	G59-92	G43-92	G60-92	G44-92
96	3.0000	3.063	G59-96	G43-96	G60-96	G44-96
100	3.1250	3.188	G59-100	G43-100	G60-100	G44-100
104	3.2500	3.313	G59-104	G43-104	G60-104	G44-104
108	3.3750	3.438	G59-108	G43-108	G60-108	G44-108
112	3.5000	3.563	G59-112	G43-112	G60-112	G44-112
116	3.6250	3.688	G59-116	G43-116	G60-116	G44-116
120	3.7500	3.813	G59-120	G43-120	G60-120	G44-120
128	4.0000	4.063	G59-128	G43-128	G60-128	G44-128

Other Size Bores Available. Consult Factory

SPUR GEAR-32 PITCH — 3/8" Face Width ■ 20° Pressure Angle

Pin Hub — 3/8" Bore

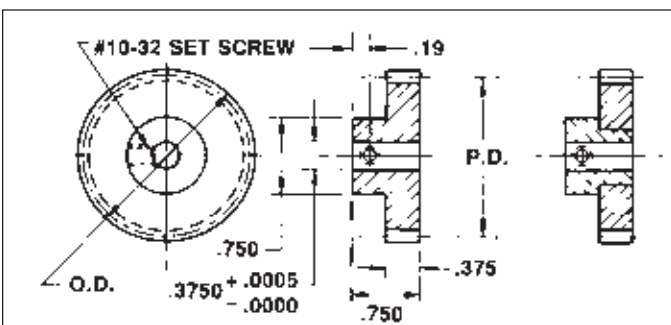

TOLERANCES

AGMA Quality Number 10-C	Tooth-to-Tooth Composite	Total Composite
Up to 20 Teeth Inclusive	.0007	.0010
Over 20 Teeth—up to 1.999" P.D.	.0005	.0010
Over 20 Teeth—2" to 2.999" P.D.	.0005	.0012
Over 20 Teeth—4" P.D. and over	.0005	.0014

"C"—BACKLASH DESIGNATION.

Provides .0005 to .001 tooth thinning at pitch line. Allows operation on theoretical centers.

Gear Data			#303 STAINLESS STEEL Part No.	BRONZE Alloy 454 Part No.
No. Teeth	P.D.	O.D.	Part No.	Part No.
28	.8750	.938	G81-28	G82-28
30	.9375	1.000	G81-30	G82-30
32	1.0000	1.063	G81-32	G82-32
36	1.1250	1.188	G81-36	G82-36
40	1.2500	1.313	G81-40	G82-40
48	1.5000	1.563	G81-48	G82-48
56	1.7500	1.813	G81-56	G82-56
60	1.8750	1.938	G81-60	G82-60
64	2.0000	2.063	G81-64	G82-64
72	2.2500	2.313	G81-72	G82-72
80	2.5000	2.563	G81-80	G82-80
96	3.0000	3.063	G81-96	G82-96
112	3.5000	3.563	G81-112	G82-112
128	4.0000	4.063	G81-128	G82-128
144	4.5000	4.563	G81-144	G82-144
160	5.0000	5.063	G81-160	G82-160

SPUR GEAR-48 PITCH — 1/8" Face Width ■ 20° Pressure Angle

Pin Hub — 1/8", 3/16", 1/4" Bores

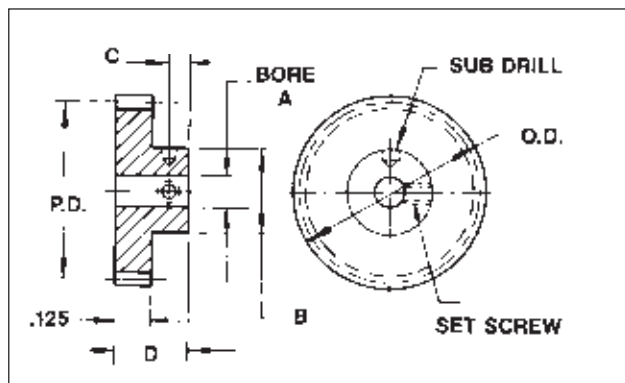

Material: 303 Stainless Steel
2024-T4 Aluminum
(Anodized Before Cutting)

Dimen.	Bore		
	1/8	3/16	1/4
A	1248	.1873	.2498
B	.312	.375	.500
C	.09	.11	.12
D	.312	.343	.375
Set Screw	#2-56	#4-40	#6-32

Tolerances	Q10	Q12	Q14
Bore	+ .0005 - .0000	+ .0003 - .0000	+ .0002 - .0000
Pitch Diameter	+ .000 - .001	+ .0000 - .0007	+ .0000 - .0005
Outside Diameter	+ .000 - .002	+ .0000 - .0015	+ .000 - .001
Total Composite Tolerance	FOR AGMA QUALITY STANDARDS		
Tooth to Tooth Tolerance	SEE PAGE 12-2		

To order AGMA 12 Gears, add - Q12 to Part No.
To order AGMA 14 Gears, add - Q14 to Part No.

For gears with a number of teeth not shown within the range listed above, substitute the required number of teeth for the digits at the end of the Part Number.
Pricing can be determined by using our online E-Commerce price list for the next higher published part number in the listing.

Gear Data	Stainless Steel Part No. Bore Size			Aluminum Part No. Bore Size					
	No. Teeth	P.D.	D.O.	.1248	.1873	.2498	.1248	.1873	.2498
18	.3750	.417	G61-18	G1-18*	—	G62-18	G2-18*	—	—
19	.3958	.438	G61-19	G1-19*	—	G62-19	G2-19*	—	—
20	.4166	.458	G61-20	G1-20*	G3-20*	G62-20	G2-20*	G4-20*	—
21	.4375	.479	G61-21	G1-21	G3-21*	G62-21	G2-21	G4-21*	—
22	.4583	.500	G61-22	G1-22	G3-22*	G62-22	G2-22	G4-22*	—
23	.4791	.521	G61-23	G1-23	G3-23*	G62-23	G2-23	G4-23*	—
24	.5000	.542	G61-24	G1-24	G3-24*	G62-24	G2-24	G4-24*	—
25	.5208	.563	G61-25	G1-25	G3-25*	G62-25	G2-25	G4-25*	—
26	.5416	.583	G61-26	G1-26	G3-26*	G62-26	G2-26	G4-26*	—
27	.5625	.604	G61-27	G1-27	G3-27	G62-27	G2-27	G4-27	—
28	.5833	.625	G61-28	G1-28	G3-28	G62-28	G2-28	G4-28	—
29	.6041	.646	G61-29	G1-29	G3-29	G62-29	G2-29	G4-29	—
30	.6250	.667	G61-30	G1-30	G3-30	G62-30	G2-30	G4-30	—
32	.6666	.708	G61-32	G1-32	G3-32	G62-32	G2-32	G4-32	—
34	.7083	.750	G61-34	G1-34	G3-34	G62-34	G2-34	G4-34	—
36	.7500	.792	G61-36	G1-36	G3-36	G62-36	G2-36	G4-36	—
38	.7916	.833	G61-38	G1-38	G3-38	G62-38	G2-38	G4-38	—
40	.8333	.875	G61-40	G1-40	G3-40	G62-40	G2-40	G4-40	—
42	.8750	.917	G61-42	G1-42	G3-42	G62-42	G2-42	G4-42	—
44	.9166	.958	G61-44	G1-44	G3-44	G62-44	G2-44	G4-44	—
46	.9583	1.000	G61-46	G1-46	G3-46	G62-46	G2-46	G4-46	—
48	1.0000	1.042	G61-48	G1-48	G3-48	G62-48	G2-48	G4-48	—
50	1.0416	1.083	G61-50	G1-50	G3-50	G62-50	G2-50	G4-50	—
55	1.1458	1.188	G61-55	G1-55	G3-55	G62-55	G2-55	G4-55	—
56	1.1666	1.208	G61-56	G1-56	G3-56	G62-56	G2-56	G4-56	—
60	1.2500	1.292	G61-60	G1-60	G3-60	G62-60	G2-60	G4-60	—
64	1.3333	1.375	G61-64	G1-64	G3-64	G62-64	G2-64	G4-64	—
65	1.3541	1.396	G61-65	G1-65	G3-65	G62-65	G2-65	G4-65	—
70	1.4583	1.500	G61-70	G1-70	G3-70	G62-70	G2-70	G4-70	—
72	1.5000	1.542	G61-72	G1-72	G3-72	G62-72	G2-72	G4-72	—
75	1.5625	1.604	G61-75	G1-75	G3-75	G62-75	G2-75	G4-75	—
80	1.6666	1.708	G61-80	G1-80	G3-80	G62-80	G2-80	G4-80	—
84	1.7500	1.792	G61-84	G1-84	G3-84	G62-84	G2-84	G4-84	—
85	1.7708	1.813	G61-85	G1-85	G3-85	G62-85	G2-85	G4-85	—
90	1.8750	1.917	G61-90	G1-90	G3-90	G62-90	G2-90	G4-90	—
92	1.9166	1.958	G61-92	G1-92	G3-92	G62-92	G2-92	G4-92	—
95	1.9791	2.021	G61-95	G1-95	G3-95	G62-95	G2-95	G4-95	—
96	2.0000	2.042	G61-96	G1-96	G3-96	G62-96	G2-96	G4-96	—
100	2.0833	2.125	G61-100	G1-100	G3-100	G62-100	G2-100	G4-100	—
102	2.1250	2.167	G61-102	G1-102	G3-102	G62-102	G2-102	G4-102	—
105	2.1875	2.229	G61-105	G1-105	G3-105	G62-105	G2-105	G4-105	—
108	2.2500	2.292	—	G1-108	G3-108	—	G2-108	G4-108	—
110	2.2917	2.333	—	G1-110	G3-110	—	G2-110	G4-110	—
115	2.3958	2.438	—	G1-115	G3-115	—	G2-115	G4-115	—
120	2.5000	2.542	—	G1-120	G3-120	—	G2-120	G4-120	—
126	2.6250	2.667	—	G1-126	G3-126	—	G2-126	G4-126	—
127	2.6458	2.688	—	G1-127	G3-127	—	G2-127	G4-127	—
132	2.7500	2.792	—	G1-132	G3-132	—	G2-132	G4-132	—
138	2.8750	2.917	—	G1-138	G3-138	—	G2-138	G4-138	—
144	3.0000	3.042	—	G1-144	G3-144	—	G2-144	G4-144	—
150	3.1250	3.167	—	G1-150	G3-150	—	G2-150	G4-150	—
156	3.2500	3.292	—	—	G3-156	—	—	G4-156	—
162	3.3750	3.417	—	—	G3-162	—	—	G4-162	—
168	3.5000	3.542	—	—	G3-168	—	—	G4-168	—
174	3.6250	3.667	—	—	G3-174	—	—	G4-174	—
180	3.7500	3.792	—	—	G3-180	—	—	G4-180	—
186	3.8750	3.917	—	—	G3-186	—	—	G4-186	—
192	4.0000	4.042	—	—	G3-192	—	—	G4-192	—
198	4.1250	4.167	—	—	G3-198	—	—	G4-198	—

Other Size Bores Available, Consult Factory.

*Hob cuts into hub

SPUR GEAR-48 PITCH — 1/8" Face Width ■ 20° Pressure Angle

Split Hub — 1/8", 3/16", 1/4" Bores ■ Hubless 3/8" Bore

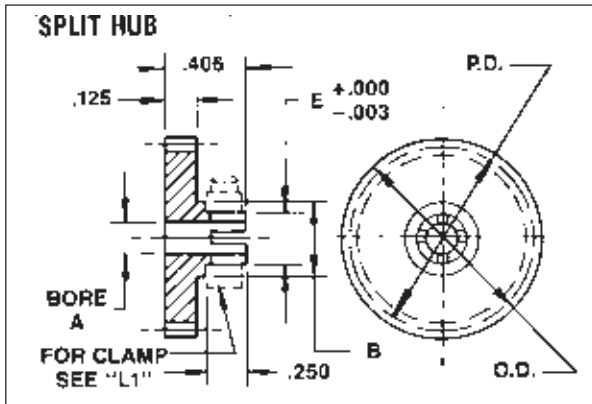

Dimen.	Bore		
	1/8	3/16	1/4
A	1248	1873	2498
B	1/4	5/16	3/8
E	.188	.250	.312

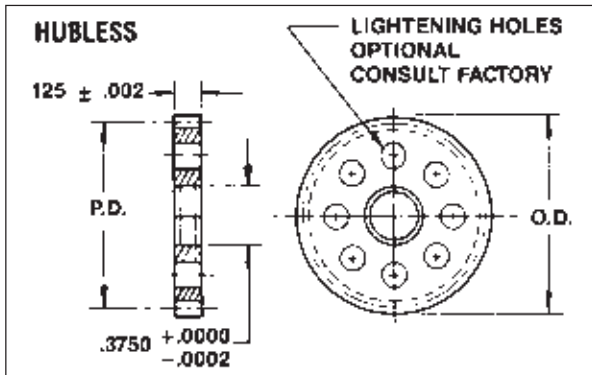

Material: 303 Stainless Steel
2024-T4 Aluminum
(Anodized Before Cutting)

Tolerances	Q10	Q12	Q14
Bore	+ .0005 - .0000	+ .0003 - .0000	+ .0002 - .0000
Pitch Diameter	+ .000 - .001	+ .0000 - .0007	+ .0000 - .0005
Outside Diameter	+ .000 - .002	+ .0000 - .0015	+ .000 - .001
Total Composite Tolerance	FOR AGMA QUALITY STANDARDS		
Tooth to Tooth Tolerance	SEE PAGE 12 2		

To order AGMA 12 Gears, add — Q12 to Part No.
To order AGMA 14 Gears, add — Q14 to Part No.

Gear Data			Stainless Steel Part No. Bore Size				Aluminum Part No. Bore Size			
No. Teeth	P.D.	O.D.	Split Hub		Hubless	Split Hub		Hubless		
			.1248	.1873	.2498	.3750	.1248	.1873	.2498	.3750
16	.3333	.375	H55-16	—	—	H56-16	—	—	—	
17	.3541	.396	H55-17	—	—	H56-17	—	—	—	
18	.3750	.417	H55-18	H57-18	—	H56-18	H58-18	—	—	
19	.3958	.438	H55-19	H57-19	—	H56-19	H58-19	—	—	
20	.4166	.458	H55-20	H57-20	—	H56-20	H58-20	—	—	
21	.4375	.479	H55-21	H57-21	H1-21	H56-21	H58-21	H2-21	—	
22	.4583	.500	H55-22	H57-22	H1-22	H56-22	H58-22	H2-22	—	
23	.4791	.521	H55-23	H57-23	H1-23	H56-23	H58-23	H2-23	—	
24	.5000	.542	H55-24	H57-24	H1-24	H56-24	H58-24	H2-24	—	
25	.5208	.563	H55-25	H57-25	H1-25	H56-25	H58-25	H2-25	—	
26	.5416	.583	H55-26	H57-26	H1-26	H56-26	H58-26	H2-26	—	
27	.5625	.604	H55-27	H57-27	H1-27	H56-27	H58-27	H2-27	—	
28	.5833	.625	H55-28	H57-28	H1-28	H56-28	H58-28	H2-28	—	
29	.6041	.646	H55-29	H57-29	H1-29	H56-29	H58-29	H2-29	J2-29	
30	.6250	.667	H55-30	H57-30	H1-30	H56-30	H58-30	H2-30	J2-30	
32	.6666	.708	H55-32	H57-32	H1-32	J1-32	H56-32	H58-32	H2-32	J2-32
34	.7083	.750	H55-34	H57-34	H1-34	J1-34	H56-34	H58-34	H2-34	J2-34
36	.7500	.792	H55-36	H57-36	H1-36	J1-36	H56-36	H58-36	H2-36	J2-36
38	.7916	.833	H55-38	H57-38	H1-38	J1-38	H56-38	H58-38	H2-38	J2-38
40	.8333	.875	H55-40	H57-40	H1-40	J1-40	H56-40	H58-40	H2-40	J2-40
42	.8750	.917	H55-42	H57-42	H1-42	J1-42	H56-42	H58-42	H2-42	J2-42
44	.9166	.958	H55-44	H57-44	H1-44	J1-44	H56-44	H58-44	H2-44	J2-44
46	.9583	1.000	H55-46	H57-46	H1-46	J1-46	H56-46	H58-46	H2-46	J2-46
48	1.0000	1.042	H55-48	H57-48	H1-48	J1-48	H56-48	H58-48	H2-48	J2-48
50	1.0416	1.083	H55-50	H57-50	H1-50	J1-50	H56-50	H58-50	H2-50	J2-50
55	1.1458	1.188	H55-55	H57-55	H1-55	J1-55	H56-55	H58-55	H2-55	J2-55
56	1.1666	1.208	H55-56	H57-56	H1-56	J1-56	H56-56	H58-56	H2-56	J2-56
60	1.2500	1.292	H55-60	H57-60	H1-60	J1-60	H56-60	H58-60	H2-60	J2-60
66	1.3750	1.417	H55-66	H57-66	H1-66	J1-66	H56-66	H58-66	H2-66	J2-66
72	1.5000	1.542	H55-72	H57-72	H1-72	J1-72	H56-72	H58-72	H2-72	J2-72
78	1.6250	1.667	H55-78	H57-78	H1-78	J1-78	H56-78	H58-78	H2-78	J2-78
84	1.7500	1.792	H55-84	H57-84	H1-84	J1-84	H56-84	H58-84	H2-84	J2-84
90	1.8750	1.917	H55-90	H57-90	H1-90	J1-90	H56-90	H58-90	H2-90	J2-90
96	2.0000	2.042	H55-96	H57-96	H1-96	J1-96	H56-96	H58-96	H2-96	J2-96
102	2.1250	2.167	H55-102	H57-102	H1-102	J1-102	H56-102	H58-102	H2-102	J2-102
108	2.2500	2.292	H55-108	H57-108	H1-108	J1-108	H56-108	H58-108	H2-108	J2-108
114	2.3750	2.417	H55-114	H57-114	H1-114	J1-114	H56-114	H58-114	H2-114	J2-114
120	2.5000	2.542	H55-120	H57-120	H1-120	J1-120	H56-120	H58-120	H2-120	J2-120
127	2.6458	2.688	H55-127	H57-127	H1-127	J1-127	H56-127	H58-127	H2-127	J2-127
132	2.7500	2.792	H55-132	H57-132	H1-132	J1-132	H56-132	H58-132	H2-132	J2-132
144	3.0000	3.042	H55-144	H57-144	H1-144	J1-144	H56-144	H58-144	H2-144	J2-144
156	3.2500	3.292	H55-156	H57-156	H1-156	J1-156	H56-156	H58-156	H2-156	J2-156
168	3.5000	3.542	H55-168	H57-168	H1-168	J1-168	H56-168	H58-168	H2-168	J2-168
180	3.7500	3.792	H55-180	H57-180	H1-180	J1-180	H56-180	H58-180	H2-180	J2-180
192	4.0000	4.042	H55-192	H57-192	H1-192	J1-192	H56-192	H58-192	H2-192	J2-192

Other Size Bores Available. Consult Factory

FOR SPECIAL SPUR GEARS ORDER AS FOLLOWS:

For Unlisted Number of Teeth, Specify the Number of Teeth desired as the last figure in the part number
EXAMPLE: H57-40 and H57-48 are in the above table for a 59 Tooth Gear. Specify Part Number H57-59

For Gear Hubs See Pages 12-65 & 12-66

SPUR GEAR-48 PITCH — 3/16" Face Width ■ 20° Pressure Angle

Pin Hub — 3/16", 1/4" Bores

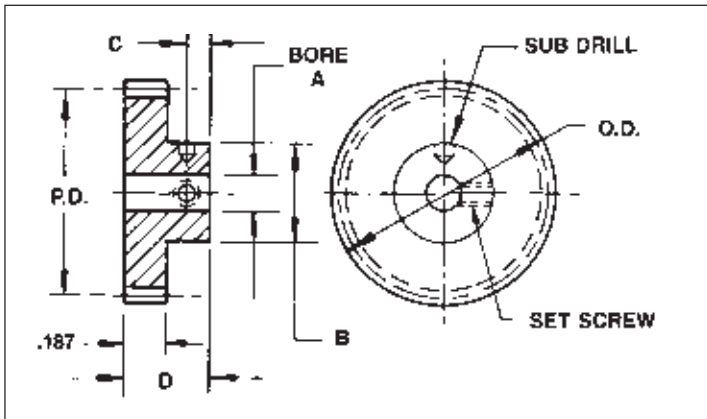

Material: 303 Stainless Steel
2024-T4 Aluminum
(Anodized Before Cutting)

Dimen.	Bore	
	3/16	1/4
A	.1873	.2498
B	.375	.500
C	.11	.12
D	.406	.437
Set Screw	#4-40	#6-32

Tolerances	Q10	Q12	Q14
Bore	+ .0005 - .0009	+ .0003 - .0000	+ .0002 - .0000
Pitch Diameter	+ .000 - .001	+ .0000 - .0007	+ .0000 - .0005
Outside Diameter	+ .000 - .002	+ .0000 - .0015	+ .000 - .001
Total Composite Tolerance	FOR AGMA QUALITY STANDARDS		
TOOTH TO TOOTH Tolerance	SEE PAGE 12 2		

To order AGMA 12 Gears, add — Q12 to Part No
To order AGMA 14 Gears, add — Q14 to Part No

For gears with a number of teeth not shown within the range listed above, substitute the required number of teeth for the digits at the end of the Part Number.

Pricing can be determined by using our online E-Commerce price list for the next higher published part number in the listing.

Gear Data			Stainless Steel Part No. Bore Size		Aluminum Part No. Bore Size	
No. Teeth	P.D.	O.D.	.1873	.2498	.1873	.2498
21	.4375	.479	G5-21	—	G6-21	—
22	.4583	.500	G5-22	—	G6-22	—
23	.4791	.521	G5-23	—	G6-23	—
24	.5000	.542	G5-24	—	G6-24	—
25	.5208	.563	G5-25	—	G6-25	—
26	.5416	.583	G5-26	—	G6-26	—
27	.5625	.604	G5-27	G7-27	G6-27	G8-27
28	.5833	.625	G5-28	G7-28	G6-28	G8-28
29	.6041	.646	G5-29	G7-29	G6-29	G8-29
30	.6250	.667	G5-30	G7-30	G6-30	G8-30
32	.6666	.708	G5-32	G7-32	G6-32	G8-32
34	.7083	.750	G5-34	G7-34	G6-34	G8-34
36	.7500	.792	G5-36	G7-36	G6-36	G8-36
38	.7916	.833	G5-38	G7-38	G6-38	G8-38
40	.8333	.875	G5-40	G7-40	G6-40	G8-40
42	.8750	.917	G5-42	G7-42	G6-42	G8-42
44	.9166	.958	G5-44	G7-44	G6-44	G8-44
46	.9583	1.000	G5-46	G7-46	G6-46	G8-46
48	1.0000	1.042	G5-48	G7-48	G6-48	G8-48
50	1.0416	1.083	G5-50	G7-50	G6-50	G8-50
55	1.1458	1.188	G5-55	G7-55	G6-55	G8-55
56	1.1666	1.208	G5-56	G7-56	G6-56	G8-56
60	1.2500	1.292	G5-60	G7-60	G6-60	G8-60
64	1.3333	1.375	G5-64	G7-64	G6-64	G8-64
65	1.3541	1.396	G5-65	G7-65	G6-65	G8-65
70	1.4583	1.500	G5-70	G7-70	G6-70	G8-70
72	1.5000	1.542	G5-72	G7-72	G6-72	G8-72
75	1.5625	1.604	G5-75	G7-75	G6-75	G8-75
80	1.6666	1.708	G5-80	G7-80	G6-80	G8-80
84	1.7500	1.792	G5-84	G7-84	G6-84	G8-84
85	1.7708	1.813	G5-85	G7-85	G6-85	G8-85
90	1.8750	1.917	G5-90	G7-90	G6-90	G8-90
92	1.9166	1.958	G5-92	G7-92	G6-92	G8-92
95	1.9791	2.021	G5-95	G7-95	G6-95	G8-95
96	2.0000	2.042	G5-96	G7-96	G6-96	G8-96
100	2.0833	2.125	G5-100	G7-100	G6-100	G8-100
102	2.1250	2.167	G5-102	G7-102	G6-102	G8-102
105	2.1875	2.229	G5-105	G7-105	G6-105	G8-105
108	2.2500	2.292	G5-108	G7-108	G6-108	G8-108
110	2.2917	2.333	G5-110	G7-110	G6-110	G8-110
115	2.3958	2.438	G5-115	G7-115	G6-115	G8-115
120	2.5000	2.542	G5-120	G7-120	G6-120	G8-120
126	2.6250	2.667	G5-126	G7-126	G6-126	G8-126
127	2.6458	2.688	G5-127	G7-127	G6-127	G8-127
132	2.7500	2.792	G5-132	G7-132	G6-132	G8-132
138	2.8750	2.917	G5-138	G7-138	G6-138	G8-138
144	3.0000	3.042	G5-144	G7-144	G6-144	G8-144
150	3.1250	3.167	G5-150	G7-150	G6-150	G8-150
156	3.2500	3.292	G5-156	G7-156	G6-156	G8-156
162	3.3750	3.417	G5-162	G7-162	G6-162	G8-162
168	3.5000	3.542	G5-168	G7-168	G6-168	G8-168
174	3.6250	3.667	G5-174	G7-174	G6-174	G8-174
180	3.7500	3.792	G5-180	G7-180	G6-180	G8-180
186	3.8750	3.917	G5-186	G7-186	G6-186	G8-186
192	4.0000	4.042	G5-192	G7-192	G6-192	G8-192
198	4.1250	4.167	—	G7-198	—	G8-198

Other Size Bores Available. Consult Factory.

SPUR GEAR-64 PITCH — 1/8" Face Width ■ 20° Pressure Angle

Pin Hub — 1/8", 3/16", 1/4" Bores

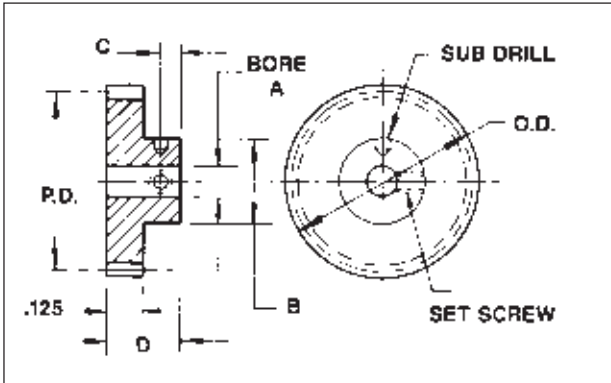

Material: 303 Stainless Steel
2024-T4 Aluminum
(Anodized Before Cutting)

Dimen.	Bore		
	1/8	3/16	1/4
A	.1248	.1873	.2498
B	.312	.375	.500
C	.09	.11	.12
D	.312	.343	.375
Set Screw	#2-56	#4-40	#6-32

Tolerances	Q10	Q12	Q14
Bore	+ .0005 - .0000	+ .0003 - .0000	+ .0002 - .0000
Pitch Diameter	+ .000 - .001	+ .0000 - .0007	+ .0000 - .0005
Outside Diameter	+ .000 - .002	+ .0000 - .0015	+ .000 - .001
Total Composite Tolerance	FOR AGMA QUALITY STANDARDS SEE PAGE 12-2		
Tooth to Tooth Tolerance	FOR AGMA QUALITY STANDARDS SEE PAGE 12-2		

To order AGMA 12 Gears, add - Q12 to Part No.
To order AGMA 14 Gears, add - Q14 to Part No.

For gears with a number of teeth not shown within the range listed above, substitute the required number of teeth for the digits at the end of the Part Number.

Pricing can be determined by using our online E-Commerce price list for the next higher published part number in the listing.

Gear Data			Stainless Steel Part No. Bore Size			Aluminum Part No. Bore Size		
No. Teeth	P.D.	O.D.	.1248	.1873	.2498	.1248	.1873	.2498
23	.3593	.391	G9-23	—	—	G10-23	—	—
24	.3750	.406	G9-24	—	—	G10-24	—	—
25	.3906	.422	G9-25	—	—	G10-25	—	—
26	.4062	.438	G9-26	—	—	G10-26	—	—
27	.4218	.453	G9-27	G11-27	—	G10-27	G12-27	—
28	.4375	.469	G9-28	G11-28	—	G10-28	G12-28	—
29	.4531	.484	G9-29	G11-29	—	G10-29	G12-29	—
30	.4687	.500	G9-30	G11-30	—	G10-30	G12-30	—
32	.5000	.531	G9-32	G11-32	—	G10-32	G12-32	—
34	.5312	.563	G9-34	G11-34	—	G10-34	G12-34	—
36	.5625	.594	G9-36	G11-36	G13-36	G10-36	G12-36	G14-36
38	.5937	.625	G9-38	G11-38	G13-38	G10-38	G12-38	G14-38
40	.6250	.656	G9-40	G11-40	G13-40	G10-40	G12-40	G14-40
42	.6562	.688	G9-42	G11-42	G13-42	G10-42	G12-42	G14-42
44	.6875	.719	G9-44	G11-44	G13-44	G10-44	G12-44	G14-44
46	.7187	.750	G9-46	G11-46	G13-46	G10-46	G12-46	G14-46
48	.7500	.781	G9-48	G11-48	G13-48	G10-48	G12-48	G14-48
50	.7812	.813	G9-50	G11-50	G13-50	G10-50	G12-50	G14-50
55	.8593	.891	G9-55	G11-55	G13-55	G10-55	G12-55	G14-55
56	.8750	.906	G9-56	G11-56	G13-56	G10-56	G12-56	G14-56
60	.9375	.969	G9-60	G11-60	G13-60	G10-60	G12-60	G14-60
64	1.0000	1.031	G9-64	G11-64	G13-64	G10-64	G12-64	G14-64
66	1.0156	1.047	G9-66	G11-66	G13-66	G10-66	G12-66	G14-66
70	1.0937	1.125	G9-70	G11-70	G13-70	G10-70	G12-70	G14-70
72	1.1250	1.156	G9-72	G11-72	G13-72	G10-72	G12-72	G14-72
75	1.1718	1.203	G9-75	G11-75	G13-75	G10-75	G12-75	G14-75
80	1.2500	1.281	G9-80	G11-80	G13-80	G10-80	G12-80	G14-80
84	1.3125	1.344	G9-84	G11-84	G13-84	G10-84	G12-84	G14-84
85	1.3281	1.359	G9-85	G11-85	G13-85	G10-85	G12-85	G14-85
88	1.3750	1.406	G9-88	G11-88	G13-88	G10-88	G12-88	G14-88
90	1.4062	1.438	G9-90	G11-90	G13-90	G10-90	G12-90	G14-90
92	1.4375	1.469	G9-92	G11-92	G13-92	G10-92	G12-92	G14-92
95	1.4843	1.516	G9-95	G11-95	G13-95	G10-95	G12-95	G14-95
96	1.5000	1.531	G9-96	G11-96	G13-96	G10-96	G12-96	G14-96
100	1.5625	1.594	G9-100	G11-100	G13-100	G10-100	G12-100	G14-100
104	1.6250	1.656	G9-104	G11-104	G13-104	G10-104	G12-104	G14-104
105	1.6406	1.672	G9-105	G11-105	G13-105	G10-105	G12-105	G14-105
112	1.7500	1.781	G9-112	G11-112	G13-112	G10-112	G12-112	G14-112
120	1.8750	1.906	G9-120	G11-120	G13-120	G10-120	G12-120	G14-120
127	1.9843	2.016	G9-127	G11-127	G13-127	G10-127	G12-127	G14-127
128	2.0000	2.031	G9-128	G11-128	G13-128	G10-128	G12-128	G14-128
136	2.1250	2.156	G9-136	G11-136	G13-136	G10-136	G12-136	G14-136
144	2.2500	2.281	—	G11-144	G13-144	—	G12-144	G14-144
152	2.3750	2.406	—	G11-152	G13-152	—	G12-152	G14-152
160	2.5000	2.531	—	G11-160	G13-160	—	G12-160	G14-160
168	2.6250	2.656	—	G11-168	G13-168	—	G12-168	G14-168
176	2.7500	2.781	—	G11-176	G13-176	—	G12-176	G14-176
184	2.8750	2.906	—	G11-184	G13-184	—	G12-184	G14-184
192	3.0000	3.031	—	G11-192	G13-192	—	G12-192	G14-192
200	3.1250	3.156	—	G11-200	G13-200	—	G12-200	G14-200
208	3.2500	3.281	—	—	G13-208	—	—	G14-208
216	3.3750	3.406	—	—	G13-216	—	—	G14-216
224	3.5000	3.531	—	—	G13-224	—	—	G14-224
232	3.6250	3.656	—	—	G13-232	—	—	G14-232
240	3.7500	3.781	—	—	G13-240	—	—	G14-240
248	3.8750	3.906	—	—	G13-248	—	—	G14-248
256	4.0000	4.031	—	—	G13-256	—	—	G14-256
264	4.1250	4.156	—	—	G13-264	—	—	G14-264

Other Size Bores Available. Consult Factory.

SPUR GEAR-64 PITCH — 3/16" Face Width ■ 20° Pressure Angle

Pin Hub — 3/16", 1/4" Bores

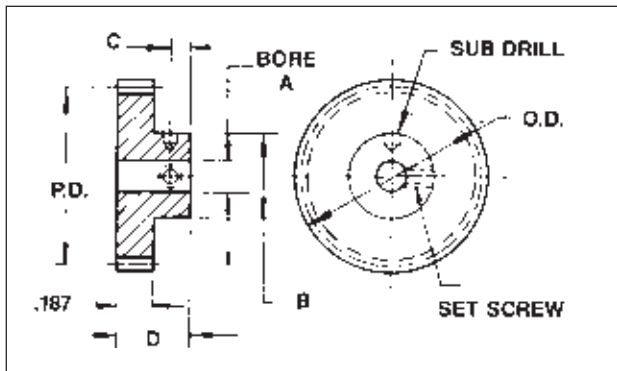

Material: 303 Stainless Steel
2024-T4 Aluminum
(Anodized Before Cutting)

Dimen.	Bore	
	3/16	1/4
A	.1873	.2498
B	.375	.500
C	.11	.12
D	.406	.437
Set Screw	#4-40	#6-32

Tolerances	Q10	Q12	Q14
Bore	+ .0005	+ .0003	+ .0002
	- .0000	- .0000	- .0000
Pitch Diameter	+ .000	+ .0000	+ .0000
	- .001	- .0007	- .0005
Outside Diameter	+ .000	+ .0000	+ .000
	- .002	- .0015	- .001
Total Composite Tolerance	FOR AGMA QUALITY STANDARDS		
Tooth to Tooth Tolerance	SEE PAGE *2-2		

To order AGMA 12 Gears, add - Q12 to Part No.
To order AGMA 14 Gears, add - Q14 to Part No.

For gears with a number of teeth not shown within the range listed above, substitute the required number of teeth for the digits at the end of the Part Number.

Pricing can be determined by using our online E-Commerce price list for the next higher published part number in the listing.

Gear Data			Stainless Steel Part No. Bore Size		Aluminum Part No. Bore Size	
No. Teeth	P.D.	O.D.	.1873	.2498	.1873	.2498
27	.4218	.453	G15-27	—	G16-27	—
28	.4375	.469	G15-28	—	G16-28	—
29	.4531	.484	G15-29	—	G16-29	—
30	.4687	.500	G15-30	G17-30	G16-30	—
32	.5000	.531	G15-32	G17-32	G16-32	—
34	.5312	.563	G15-34	G17-34	G16-34	G18-34
36	.5625	.594	G15-36	G17-36	G16-36	G18-36
38	.5937	.625	G15-38	G17-38	G16-38	G18-38
40	.6250	.656	G15-40	G17-40	G16-40	G18-40
42	.6562	.688	G15-42	G17-42	G16-42	G18-42
44	.6875	.719	G15-44	G17-44	G16-44	G18-44
46	.7187	.750	G15-46	G17-46	G16-46	G18-46
48	.7500	.781	G15-48	G17-48	G16-48	G18-48
50	.7812	.813	G15-50	G17-50	G16-50	G18-50
55	.8593	.891	G15-55	G17-55	G16-55	G18-55
56	.8750	.906	G15-56	G17-56	G16-56	G18-56
60	.9375	.969	G15-60	G17-60	G16-60	G18-60
64	1.0000	1.031	G15-64	G17-64	G16-64	G18-64
65	1.0156	1.047	G15-65	G17-65	G16-65	G18-65
70	1.0937	1.125	G15-70	G17-70	G16-70	G18-70
72	1.1250	1.156	G15-72	G17-72	G16-72	G18-72
75	1.1718	1.203	G15-75	G17-75	G16-75	G18-75
80	1.2500	1.281	G15-80	G17-80	G16-80	G18-80
84	1.3125	1.344	G15-84	G17-84	G16-84	G18-84
85	1.3281	1.359	G15-85	G17-85	G16-85	G18-85
88	1.3750	1.406	G15-88	G17-88	G16-88	G18-88
90	1.4062	1.438	G15-90	G17-90	G16-90	G18-90
92	1.4375	1.469	G15-92	G17-92	G16-92	G18-92
95	1.4843	1.516	G15-95	G17-95	G16-95	G18-95
96	1.5000	1.531	G15-96	G17-96	G16-96	G18-96
100	1.5625	1.594	G15-100	G17-100	G16-100	G18-100
104	1.6250	1.656	G15-104	G17-104	G16-104	G18-104
106	1.6406	1.672	G15-106	G17-106	G16-106	G18-106
112	1.7500	1.781	G15-112	G17-112	G16-112	G18-112
120	1.8750	1.906	G15-120	G17-120	G16-120	G18-120
127	1.9843	2.016	G15-127	G17-127	G16-127	G18-127
128	2.0000	2.031	G15-128	G17-128	G16-128	G18-128
136	2.1250	2.156	G15-136	G17-136	G16-136	G18-136
144	2.2500	2.281	G15-144	G17-144	G16-144	G18-144
152	2.3750	2.406	G15-152	G17-152	G16-152	G18-152
160	2.5000	2.531	G15-160	G17-160	G16-160	G18-160
168	2.6250	2.656	G15-168	G17-168	G16-168	G18-168
176	2.7500	2.781	G15-176	G17-176	G16-176	G18-176
184	2.8750	2.906	G15-184	G17-184	G16-184	G18-184
192	3.0000	3.031	G15-192	G17-192	G16-192	G18-192
200	3.1250	3.156	G15-200	G17-200	G16-200	G18-200
208	3.2500	3.281	G15-208	G17-208	G16-208	G18-208
216	3.3750	3.406	G15-216	G17-216	G16-216	G18-216
224	3.5000	3.531	G15-224	G17-224	G16-224	G18-224
232	3.6250	3.656	G15-232	G17-232	G16-232	G18-232
240	3.7500	3.781	G15-240	G17-240	G16-240	G18-240
248	3.8750	3.906	G15-248	G17-248	G16-248	G18-248
256	4.0000	4.031	G15-256	G17-256	G16-256	G18-256

Other Size Bores Available. Consult Factory.

SPUR GEAR-64 PITCH — 1/8" Face Width ■ 20° Pressure Angle

Split Hub — 1/8", 3/16", 1/4" Bores ■ Hubless 3/8" Bore

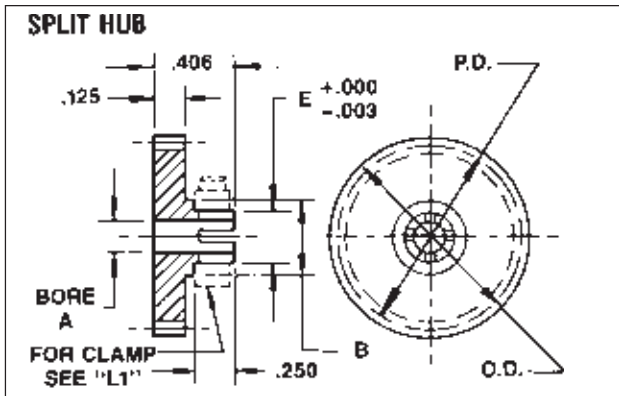

Dimen.	Bore		
	1/8	3/16	1/4
A	.1248	.1873	.2498
B	1/4	5/16	3/8
E	188	.250	312

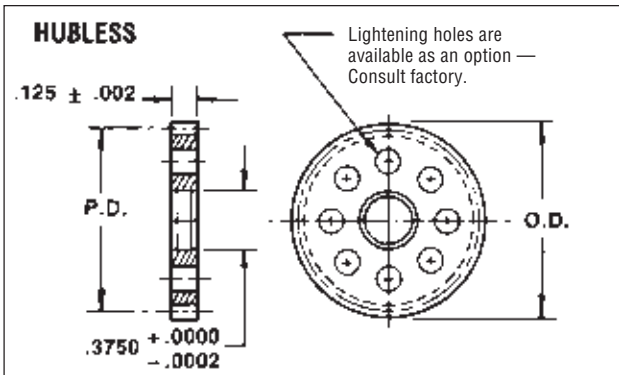

Material: 303 Stainless Steel
2024-T4 Aluminum
(Anodized Before Cutting)

Tolerances	Q10	Q12	Q14
Bore (Split Hub)	+ .0005 - .0000	+ .0003 - .0000	+ .0002 - .0000
Pitch Diameter	+ .000 - .001	+ .0000 - .0007	+ .0000 - .0005
Outside Diameter	+ .000 - .002	+ .0000 - .0015	+ .000 - .001
Total Composite Tolerance	FOR AGMA QUALITY STANDARDS SEE PAGE 12-2		
Teeth to Teeth Tolerance			

Gear Data			Stainless Steel Part No. Bore Size				Aluminum Part No. Bore Size			
No. Teeth	P.D.	O.D.	Split Hub		Hubless	Split Hub		Hubless		
			.1248	.1873	.2498	.3750	.1248	.1873	.2498	.3750
19	2969	328	H47-19	—	—	H48-19	—	—	—	
20	3125	344	H47-20	—	—	H48-20	—	—	—	
21	3281	359	H47-21	—	—	H48-21	—	—	—	
22	3437	375	H47-22	—	H49-22	H48-22	—	—	—	
23	3593	391	H47-23	H3-23	H49-23	—	H48-23	H4-23	—	
24	3750	406	H47-24	H3-24	H49-24	—	H48-24	H4-24	—	
25	3906	422	H47-25	H3-25	H49-25	—	H48-25	H4-25	—	
26	4062	438	H47-26	H3-26	H49-26	—	H48-26	H4-26	—	
27	4218	453	H47-27	H3-27	H49-27	—	H48-27	H4-27	H50-27	
28	4375	469	H47-28	H3-28	H49-28	—	H48-28	H4-28	H50-28	
29	4531	484	H47-29	H3-29	H49-29	—	H48-29	H4-29	H50-29	
30	4687	500	H47-30	H3-30	H49-30	—	H48-30	H4-30	H50-30	
32	5000	531	H47-32	H3-32	H49-32	—	H48-32	H4-32	H50-32	
34	5312	563	H47-34	H3-34	H49-34	—	H48-34	H4-34	H50-34	
36	5625	594	H47-36	H3-36	H49-36	—	H48-36	H4-36	H50-36	
38	5937	625	H47-38	H3-38	H49-38	J3-38	H48-38	H4-38	H50-38	
40	6250	656	H47-40	H3-40	H49-40	J3-40	H48-40	H4-40	H50-40	
42	6562	688	H47-42	H3-42	H49-42	J3-42	H48-42	H4-42	H50-42	
44	6875	719	H47-44	H3-44	H49-44	J3-44	H48-44	H4-44	H50-44	
46	7187	750	H47-46	H3-46	H49-46	J3-46	H48-46	H4-46	H50-46	
48	7500	781	H47-48	H3-48	H49-48	J3-48	H48-48	H4-48	H50-48	
50	7812	813	H47-50	H3-50	H49-50	J3-50	H48-50	H4-50	H50-50	
55	8593	891	H47-55	H3-55	H49-55	J3-55	H48-55	H4-55	H50-55	
56	8750	906	H47-56	H3-56	H49-56	J3-56	H48-56	H4-56	H50-56	
60	9375	969	H47-60	H3-60	H49-60	J3-60	H48-60	H4-60	H50-60	
64	1.0000	1.031	H47-64	H3-64	H49-64	J3-64	H48-64	H4-64	H50-64	
72	1.1250	1.156	H47-72	H3-72	H49-72	J3-72	H48-72	H4-72	H50-72	
80	1.2500	1.281	H47-80	H3-80	H49-80	J3-80	H48-80	H4-80	H50-80	
88	1.3750	1.406	H47-88	H3-88	H49-88	J3-88	H48-88	H4-88	H50-88	
96	1.5000	1.531	H47-96	H3-96	H49-96	J3-96	H48-96	H4-96	H50-96	
104	1.6250	1.656	H47-104	H3-104	H49-104	J3-104	H48-104	H4-104	H50-104	
112	1.7500	1.781	H47-112	H3-112	H49-112	J3-112	H48-112	H4-112	H50-112	
120	1.8750	1.906	H47-120	H3-120	H49-120	J3-120	H48-120	H4-120	H50-120	
127	1.9843	2.016	—	—	H49-127	J3-127	—	—	H50-127	
128	2.0000	2.031	—	—	H49-128	J3-128	—	—	H50-128	
136	2.1250	2.156	—	—	H49-136	J3-136	—	—	H50-136	
144	2.2500	2.281	—	—	H49-144	J3-144	—	—	H50-144	
160	2.5000	2.531	—	—	H49-160	J3-160	—	—	H50-160	
176	2.7500	2.781	—	—	H49-176	J3-176	—	—	H50-176	
192	3.0000	3.031	—	—	H49-192	J3-192	—	—	H50-192	
208	3.2500	3.281	—	—	H49-208	J3-208	—	—	H50-208	
224	3.5000	3.531	—	—	H49-224	J3-224	—	—	H50-224	
240	3.7500	3.781	—	—	H49-240	J3-240	—	—	H50-240	
240	—	—	—	—	H49-256	J3-256	—	—	H50-256	
264	—	—	—	—	H49-264	J3-264	—	—	H50-264	

Other Size Bores Available. Consult Factory

For Gear Hubs See Pages 12-67 & 12-68

SPUR GEAR-72 PITCH — 1/8" Face Width ■ 20° Pressure Angle

Pin Hub — 1/8", 3/16" Bores

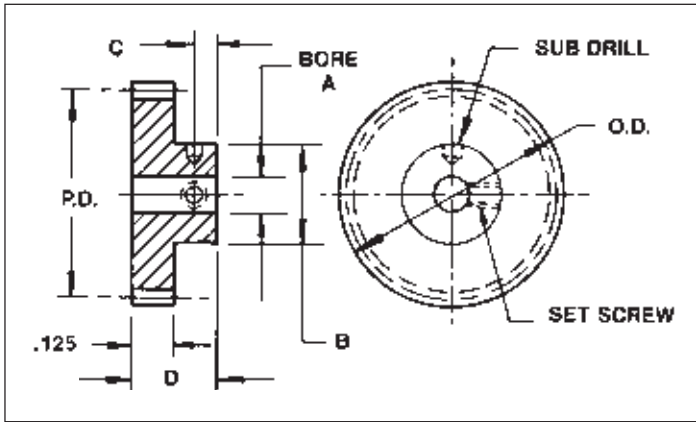

Material: 303 Stainless Steel
2024-T4 Aluminum
(Anodized Before Cutting)

Dimen.	Bore	
	1/8	3/16
A	.1248	.1873
B	.312	.375
C	.09	.11
D	.312	.343
Set Screw	#2-55	#4-40

Tolerances	Q10	Q12	Q14
Bore	+ .0005 - .0000	+ .0003 - .0000	+ .0002 - .0000
Pitch Diameter	+ .000 - .001	+ .0000 - .0007	+ .0000 - .0005
Outside Diameter	+ .000 - .002	+ .0000 - .0015	+ .000 - .001
Total Composite Tolerance	FOR AGMA QUALITY STANDARDS		
Tooth to Tooth Tolerance	SEE PAGL 12-2		

To order AGMA 12 Gears, add - Q12 to Part No.
To order AGMA 14 Gears, add - Q14 to Part No.

For gears with a number of teeth not shown within the range listed above, substitute the required number of teeth for the digits at the end of the Part Number.

Pricing can be determined by using our online E-Commerce price list for the next higher published part number in the listing.

Gear Data			Stainless Steel Part No. Bore Size		Aluminum Part No. Bore Size	
No. Teeth	P.D.	O.D.	.1248	.1873	.1248	.1873
26	.3610	.389	G19-26	—	G20-26	—
27	.3750	.403	G19-27	—	G20-27	—
28	.3888	.417	G19-28	—	G20-28	—
30	.4166	.444	G19-30	G21-30	G20-30	G22-30
32	.4444	.472	G19-32	G21-32	G20-32	G22-32
34	.4722	.500	G19-34	G21-34	G20-34	G22-34
36	.5000	.528	G19-36	G21-36	G20-36	G22-36
38	.5277	.556	G19-38	G21-38	G20-38	G22-38
40	.5555	.583	G19-40	G21-40	G20-40	G22-40
42	.5833	.611	G19-42	G21-42	G20-42	G22-42
44	.6111	.639	G19-44	G21-44	G20-44	G22-44
45	.6250	.653	G19-45	G21-45	G20-45	G22-45
46	.6388	.667	G19-46	G21-46	G20-46	G22-46
48	.6666	.694	G19-48	G21-48	G20-48	G22-48
50	.6944	.722	G19-50	G21-50	G20-50	G22-50
54	.7500	.778	G19-54	G21-54	G20-54	G22-54
55	.7638	.792	G19-55	G21-55	G20-55	G22-55
56	.7777	.806	G19-56	G21-56	G20-56	G22-56
60	.8333	.861	G19-60	G21-60	G20-60	G22-60
63	.8750	.903	G19-63	G21-63	G20-63	G22-63
64	.8888	.917	G19-64	G21-64	G20-64	G22-64
70	.9722	1.000	G19-70	G21-70	G20-70	G22-70
72	1.0000	1.028	G19-72	G21-72	G20-72	G22-72
75	1.0416	1.069	G19-75	G21-75	G20-75	G22-75
80	1.1111	1.139	G19-80	G21-80	G20-80	G22-80
81	1.1250	1.153	G19-81	G21-81	G20-81	G22-81
84	1.1666	1.194	G19-84	G21-84	G20-84	G22-84
85	1.1805	1.208	G19-85	G21-85	G20-85	G22-85
90	1.2500	1.278	G19-90	G21-90	G20-90	G22-90
92	1.2777	1.306	G19-92	G21-92	G20-92	G22-92
95	1.3194	1.347	G19-95	G21-95	G20-95	G22-95
96	1.3333	1.361	G19-96	G21-96	G20-96	G22-96
99	1.3750	1.403	G19-99	G21-99	G20-99	G22-99
100	1.3888	1.417	G19-100	G21-100	G20-100	G22-100
105	1.4583	1.486	G19-105	G21-105	G20-105	G22-105
108	1.5000	1.528	G19-108	G21-108	G20-108	G22-108
110	1.5277	1.556	G19-110	G21-110	G20-110	G22-110
117	1.6249	1.653	G19-117	G21-117	G20-117	G22-117
120	1.6666	1.694	G19-120	G21-120	G20-120	G22-120
126	1.7499	1.778	G19-126	G21-126	G20-126	G22-126
127	1.7638	1.792	G19-127	G21-127	G20-127	G22-127
130	1.8055	1.833	G19-130	G21-130	G20-130	G22-130
135	1.8749	1.903	G19-135	G21-135	G20-135	G22-135
140	1.9444	1.972	G19-140	G21-140	G20-140	G22-140
144	2.0000	2.028	G19-144	G21-144	G20-144	G22-144
150	2.0833	2.111	G19-150	G21-150	G20-150	G22-150
153	2.1249	2.153	G19-153	G21-153	G20-153	G22-153
160	2.2222	2.250	—	G21-160	—	G22-160
162	2.2499	2.278	—	G21-162	—	G22-162
180	2.5000	2.528	—	G21-180	—	G22-180
198	2.7499	2.778	—	G21-198	—	G22-198
216	3.0000	3.028	—	G21-216	—	G22-216

Other Size Bores Available. Consult Factory.

SPUR GEAR-72 PITCH — 1/8" Face Width ■ 20° Pressure Angle

Split Hub — 3/16", 1/4" Bores ■ Hubless 3/8" Bore

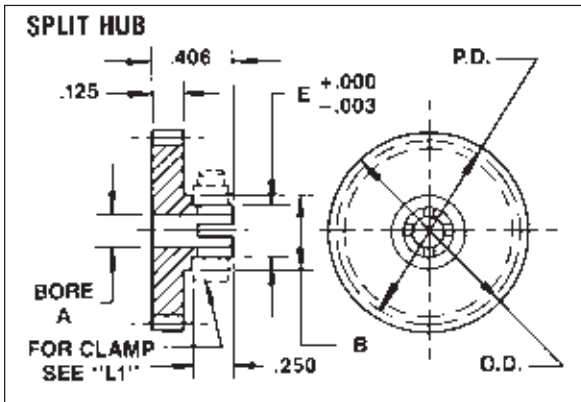

Dimen.	Bore	
	3/16	1/4
A	.1873	.2496
B	5/16	3/8
E	.250	.312

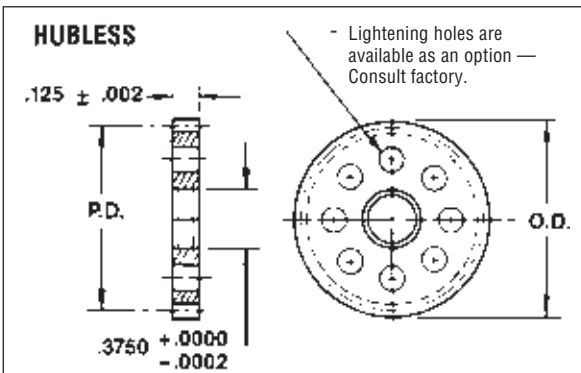

Material: 303 Stainless Steel
2024-T4 Aluminum
(Anodized Before Cutting)

Tolerances	Q10	Q12	Q14
Bore	+ .0005 - .0000	+ .0003 - .0000	+ .0002 - .0000
Pitch Diameter	+ .000 - .001	+ .0000 - .0007	+ .0000 - .0005
Outside Diameter	+ .000 - .002	+ .0000 - .0015	+ .000 - .001
Total Composite Tolerance	FOR AGMA QUALITY STANDARDS		
Tooth to Tooth Tolerance	SEE PAGE 12-2		

To order AGMA 12 Gears, add - Q12 to Part No
To order AGMA 14 Gears, add - Q14 to Part No

For gears with a number of teeth not shown within the range listed above, substitute the required number of teeth for the digits at the end of the Part Number.

Pricing can be determined by using our online E-Commerce price list for the next higher published part number in the listing.

Gear Data			Stainless Steel Part No. Bore Size			Aluminum Part No. Bore Size		
No. Teeth	P.D.	O.D.	Split Hub		Hubless	Split Hub		Hubless
			.1873	.2496	.3750	.1873	.2496	.3750
29	.4027	.431	H5-29	—	—	H6-29	—	—
30	.4166	.444	H5-30	—	—	H6-30	—	—
32	.4444	.472	H5-32	—	—	H6-32	—	—
34	.4722	.500	H5-34	—	—	H6-34	—	—
36	.5000	.528	H5-36	H59-36	—	H6-36	H60-36	—
38	.5277	.556	H5-38	H59-38	—	H6-38	H60-38	—
40	.5555	.583	H5-40	H59-40	—	H6-40	H60-40	—
42	.5833	.611	H5-42	H59-42	—	H6-42	H60-42	—
45	.6250	.653	H5-45	H59-45	J5-45	H6-45	H60-45	J6-45
54	.7500	.778	H5-54	H59-54	J5-54	H6-54	H60-54	J6-54
63	.8750	.903	H5-63	H59-63	J5-63	H6-63	H60-63	J6-63
72	1.0000	1.028	H5-72	H59-72	J5-72	H6-72	H60-72	J6-72
81	1.1250	1.153	H5-81	H59-81	J5-81	H6-81	H60-81	J6-81
90	1.2500	1.278	H5-90	H59-90	J5-90	H6-90	H60-90	J6-90
99	1.3750	1.403	H5-99	H59-99	J5-99	H6-99	H60-99	J6-99
108	1.5000	1.528	H5-108	H59-108	J5-108	H6-108	H60-108	J6-108
117	1.6249	1.653	H5-117	H59-117	J5-117	H6-117	H60-117	J6-117
126	1.7499	1.778	H5-126	H59-126	J5-126	H6-126	H60-126	J6-126
127	1.7683	1.792	H5-127	H59-127	J5-127	H6-127	H60-127	J6-127
135	1.8749	1.903	H5-135	H59-135	J5-135	H6-135	H60-135	J6-135
144	2.0000	2.028	H5-144	H59-144	J5-144	H6-144	H60-144	J6-144
153	2.1249	2.153	H5-153	H59-153	J5-153	H6-153	H60-153	J6-153
162	2.2499	2.278	H5-162	H59-162	J5-162	H6-162	H60-162	J6-162
171	2.3749	2.403	H5-171	H59-171	J5-171	H6-171	H60-171	J6-171
180	2.5000	2.528	H5-180	H59-180	J5-180	H6-180	H60-180	J6-180
189	2.6249	2.653	H5-189	H59-189	J5-189	H6-189	H60-189	J6-189
198	2.7499	2.778	H5-198	H59-198	J5-198	H6-198	H60-198	J6-198
207	2.8750	2.903	H5-207	H59-207	J5-207	H6-207	H60-207	J6-207
216	3.0000	3.028	H5-216	H59-216	J5-216	H6-216	H60-216	J6-216
234	3.2500	3.278	—	—	J5-234	—	—	J6-234
252	3.5000	3.528	—	—	J5-252	—	—	J6-252
270	3.7500	3.778	—	—	J5-270	—	—	J6-270
288	4.0000	4.028	—	—	J5-288	—	—	J6-288
297	4.1250	4.153	—	—	J5-297	—	—	J6-297

Other Size Bores Available. Consult Factory.

For Gear Hubs See Pages 12-67 & 12-68

SPUR GEAR-72 PITCH — 3/16" Face Width ■ 20° Pressure Angle

Pin Hub — 3/16", 1/4" Bores

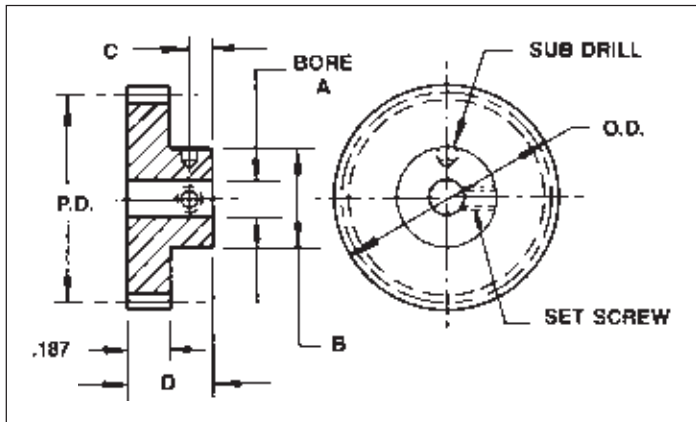

Material: 303 Stainless Steel
2024-T4 Aluminum
(Anodized Before Cutting)

Dimen.	Bore	
	3/16	1/4
A	.1873	.2498
B	.375	.500
C	.11	.12
D	.406	.437
Set Screw	#4-40	#6-32

Tolerances	Q10	Q12	Q14
Bore	+ .0005 - .0000	+ .0003 - .0000	+ .0002 - .0000
Pitch Diameter	+ .000 - .001	+ .0000 - .0007	+ .0000 - .0005
Outside Diameter	+ .000 - .002	+ .0000 - .0015	+ .000 - .001
Total Composite Tolerance	FOR AGMA QUALITY STANDARDS		
Teeth to Teeth Tolerance	SEE PAGE 12-2		

To order AGMA 12 Gears, add - Q12 to Part No
To order AGMA 14 Gears, add - Q14 to Part No

For gears with a number of teeth not shown within the range listed above, substitute the required number of teeth for the digits at the end of the Part Number.
Pricing can be determined by using our online E-Commerce price list for the next higher published part number in the listing.

Gear Data			Stainless Steel Part No. Bore Size		Aluminum Part No. Bore Size	
No. Teeth	P.D.	O.D.	.1873	.2498	.1873	.2498
30	.4166	.444	G23-30	—	G24-30	—
32	.4444	.472	G23-32	—	G24-32	—
34	.4722	.500	G23-34	—	G24-34	—
36	.5000	.528	G23-36	—	G24-36	—
38	.5277	.556	G23-38	—	G24-38	—
40	.5555	.583	G23-40	G25-40	G24-40	G26-40
42	.5833	.611	G23-42	G25-42	G24-42	G26-42
44	.6111	.639	G23-44	G25-44	G24-44	G26-44
45	.6250	.653	G23-45	G25-45	G24-45	G26-45
46	.6388	.667	G23-46	G25-46	G24-46	G26-46
48	.6666	.694	G23-48	G25-48	G24-48	G26-48
50	.6944	.722	G23-50	G25-50	G24-50	G26-50
54	.7500	.778	G23-54	G25-54	G24-54	G26-54
55	.7638	.792	G23-55	G25-55	G24-55	G26-55
56	.7777	.806	G23-56	G25-56	G24-56	G26-56
60	.8333	.861	G23-60	G25-60	G24-60	G26-60
63	.8750	.903	G23-63	G25-63	G24-63	G26-63
64	.8888	.917	G23-64	G25-64	G24-64	G26-64
70	.9722	1.000	G23-70	G25-70	G24-70	G26-70
72	1.0000	1.028	G23-72	G25-72	G24-72	G26-72
75	1.0416	1.069	G23-75	G25-75	G24-75	G26-75
80	1.1111	1.139	G23-80	G25-80	G24-80	G26-80
81	1.1250	1.153	G23-81	G25-81	G24-81	G26-81
84	1.1666	1.194	G23-84	G25-84	G24-84	G26-84
85	1.1805	1.208	G23-85	G25-85	G24-85	G26-85
90	1.2500	1.278	G23-90	G25-90	G24-90	G26-90
92	1.2777	1.306	G23-92	G25-92	G24-92	G26-92
95	1.3194	1.347	G23-95	G25-95	G24-95	G26-95
96	1.3333	1.361	G23-96	G25-96	G24-96	G26-96
99	1.3750	1.403	G23-99	G25-99	G24-99	G26-99
100	1.3888	1.417	G23-100	G25-100	G24-100	G26-100
105	1.4583	1.486	G23-105	G25-105	G24-105	G26-105
108	1.5000	1.528	G23-108	G25-108	G24-108	G26-108
110	1.5277	1.556	G23-110	G25-110	G24-110	G26-110
117	1.6249	1.653	G23-117	G25-117	G24-117	G26-117
120	1.6666	1.694	G23-120	G25-120	G24-120	G26-120
126	1.7499	1.778	G23-126	G25-126	G24-126	G26-126
127	1.7638	1.792	G23-127	G25-127	G24-127	G26-127
130	1.8055	1.833	G23-130	G25-130	G24-130	G26-130
135	1.8749	1.903	G23-135	G25-135	G24-135	G26-135
140	1.9444	1.972	G23-140	G25-140	G24-140	G26-140
144	2.0000	2.028	G23-144	G25-144	G24-144	G26-144
150	2.0833	2.111	G23-150	G25-150	G24-150	G26-150
153	2.1249	2.153	G23-153	G25-153	G24-153	G26-153
160	2.2222	2.250	G23-160	G25-160	G24-160	G26-160
162	2.2499	2.278	G23-162	G25-162	G24-162	G26-162
180	2.5000	2.528	G23-180	G25-180	G24-180	G26-180
198	2.7499	2.778	G23-198	G25-198	G24-198	G26-198
216	3.0000	3.028	G23-216	G25-216	G24-216	G26-216
234	3.2500	3.278	G23-234	G25-234	G24-234	G26-234
252	3.5000	3.528	G23-252	G25-252	G24-252	G26-252
270	3.7500	3.778	G23-270	G25-270	G24-270	G26-270
288	4.0000	4.028	G23-288	G25-288	G24-288	G26-288

Other Size Bores Available. Consult Factory.

SPUR GEAR-80 PITCH — 1/8" Face Width ■ 20° Pressure Angle

Pin Hub — 1/8", 3/16" Bores ■ Hubless 3/8" Bore

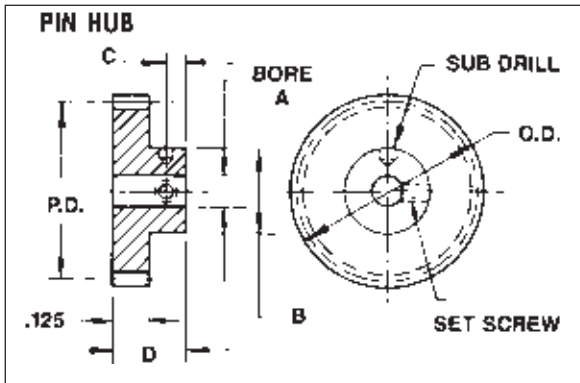

Dimen.	Bore	
	1/8	3/16
A	.1248	.1873
B	.312	.375
C	.09	.11
D	.312	.343
Set Screw	#2-56	#4-40

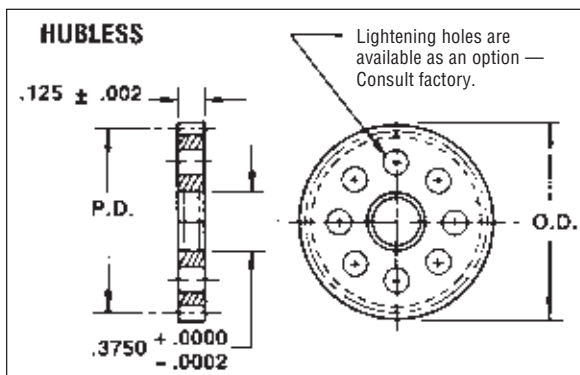

Material: 303 Stainless Steel
2024-T4 Aluminum
(Anodized Before Cutting)

Tolerances	Q10	Q12	Q14
Bore	+ .0005 - .0000	+ .0003 - .0000	+ .0002 - .0000
Pitch Diameter	+ .000 - .001	+ .0000 - .0007	+ .0000 - .0005
Outside Diameter	+ .000 - .002	+ .0000 - .0015	+ .000 - .001
Total Composite Tolerance	FOR AGMA QUALITY STANDARDS		
Tooth to Tooth Tolerance	SEE PAGE 12-2		

To order AGMA 12 Gears, add - Q12 to Part No
To order AGMA 14 Gears, add - Q14 to Part No

For gears with a number of teeth not shown within the range listed above, substitute the required number of teeth for the digits at the end of the Part Number.

Pricing can be determined by using our online E-Commerce price list for the next higher published part number in the listing.

Gear Data			Stainless Steel Part No. Bore Size			Aluminum Part No. Bore Size		
No. Teeth	P.D.	O.D.	Pin Hub		Hubless	Pin Hub		Hubless
			.1248	.1873	.3750	.1248	.1873	.3750
30	.3750	.400	G45-30	—	—	G46-30	—	—
32	.4000	.425	G45-32	—	—	G46-32	—	—
34	.4250	.450	G45-34	—	—	G46-34	—	—
35	.4375	.463	G45-35	—	—	G46-35	—	—
36	.4500	.475	G45-36	—	—	G46-36	—	—
38	.4750	.500	G45-38	G47-38	—	G46-38	G48-38	—
40	.5000	.525	G45-40	G47-40	—	G46-40	G48-40	—
42	.5250	.550	G45-42	G47-42	—	G46-42	G48-42	—
44	.5500	.575	G45-44	G47-44	—	G46-44	G48-44	—
45	.5625	.588	G45-45	G47-45	—	G46-45	G48-45	—
50	.6250	.650	G45-50	G47-50	J25-50	G46-50	G48-50	J26-50
55	.6875	.713	G45-55	G47-55	J25-55	G46-55	G48-55	J26-55
60	.7500	.775	G45-60	G47-60	J25-60	G46-60	G48-60	J26-60
65	.8125	.838	G45-65	G47-65	J25-65	G46-65	G48-65	J26-65
70	.8750	.900	G45-70	G47-70	J25-70	G46-70	G48-70	J26-70
75	.9375	.963	G45-75	G47-75	J25-75	G46-75	G48-75	J26-75
80	1.0000	1.025	G45-80	G47-80	J25-80	G46-80	G48-80	J26-80
85	1.0625	1.088	G45-85	G47-85	J25-85	G46-85	G48-85	J26-85
90	1.1250	1.150	G45-90	G47-90	J25-90	G46-90	G48-90	J26-90
100	1.2500	1.275	G45-100	G47-100	J25-100	G46-100	G48-100	J26-100
110	1.3750	1.400	G45-110	G47-110	J25-110	G46-110	G48-110	J26-110
120	1.5000	1.525	G45-120	G47-120	J25-120	G46-120	G48-120	J26-120
127	1.5875	1.613	G45-127	G47-127	J25-127	G46-127	G48-127	J26-127
130	1.6250	1.650	G45-130	G47-130	J25-130	G46-130	G48-130	J26-130
140	1.7500	1.775	G45-140	G47-140	J25-140	G46-140	G48-140	J26-140
150	1.8750	1.900	—	G47-150	J25-150	—	G48-150	J26-150
160	2.0000	2.025	—	G47-160	J25-160	—	G48-160	J26-160
170	2.1250	2.150	—	G47-170	J25-170	—	G48-170	J26-170
180	2.2500	2.275	—	G47-180	J25-180	—	G48-180	J26-180
190	2.3750	2.400	—	G47-190	J25-190	—	G48-190	J26-190
200	2.5000	2.525	—	G47-200	J25-200	—	G48-200	J26-200
220	2.7500	2.775	—	—	J25-220	—	—	J26-220

Other Size Bores Available. Consult Factory

For Gear Hubs See Pages 12-67 & 12-68

SPUR GEAR-80 PITCH — 1/8" Face Width ■ 20° Pressure Angle

Pin Hub — 1/4" Bore

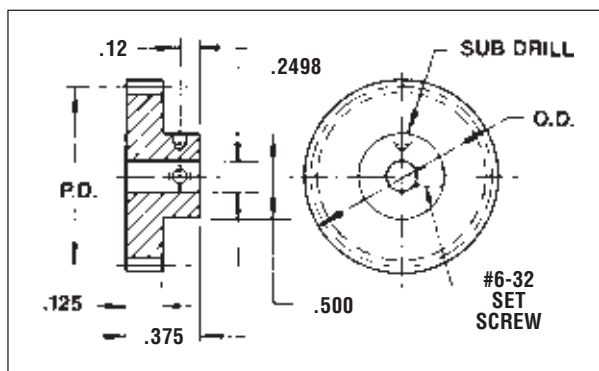

Material: 303 Stainless Steel
2024-T4 Aluminum
(Anodized Before Cutting)

Tolerances	Q10	Q12	Q14
Bore	+ .0005 - .0000	+ .0003 - .0000	+ .0002 - .0000
Pinch Diameter	+ .000 - .001	+ .0000 - .0007	+ .0000 - .0005
Outside Diameter	+ .000 - .002	+ .0000 - .0015	+ .000 - .001
Total Composite Tolerance	FOR AGMA QUALITY STANDARDS		
Tooth to Tooth Tolerance	SEE PAGE 12-2		

To order AGMA 12 Gears, add - Q12 to Part No.
To order AGMA 14 Gears, add - Q14 to Part No.

For gears with a number of teeth not shown within the range listed above, substitute the required number of teeth for the digits at the end of the Part Number.

Pricing can be determined by using our online E-Commerce price list for the next higher published part number in the listing.

Gear Data			Stainless Steel Part No.	Aluminum Part No.
No. Teeth	P.D.	O.D.		
25*	0.3125	0.338	80T25S	80T25A
26*	0.3250	0.350	80T26S	80T26A
27*	0.3375	0.363	80T27S	80T27A
28*	0.3500	0.375	80T28S	80T28A
29*	0.3625	0.388	80T29S	80T29A
30*	0.3750	0.400	80T30S	80T30A
32*	0.4000	0.425	80T32S	80T32A
33*	0.4125	0.438	80T33S	80T33A
34*	0.4250	0.450	80T34S	80T34A
35*	0.4375	0.463	80T35S	80T35A
36*	0.4500	0.475	80T36S	80T36A
38*	0.4750	0.500	80T38S	80T38A
39*	0.4875	0.513	80T39S	80T39A
40*	0.5000	0.525	80T40S	80T40A
41*	0.5125	0.538	80T41S	80T41A
42*	0.5250	0.550	80T42S	80T42A
44	0.5500	0.575	80T44S	80T44A
45	0.5625	0.588	80T45S	80T45A
50	0.6250	0.650	80T50S	80T50A
55	0.6875	0.713	80T55S	80T55A
60	0.7500	0.775	80T60S	80T60A
65	0.8125	0.838	80T65S	80T65A
70	0.8750	0.900	80T70S	80T70A
75	0.9375	0.963	80T75S	80T75A
80	1.0000	1.025	80T80S	80T80A
85	1.0625	1.088	80T85S	80T85A
90	1.1250	1.150	80T90S	80T90A
100	1.2500	1.275	80T100S	80T100A
110	1.3750	1.400	80T110S	80T110A
120	1.5000	1.525	80T120S	80T120A
130	1.6250	1.650	80T130S	80T130A
140	1.7500	1.775	80T140S	80T140A
150	1.8750	1.900	80T150S	80T150A
160	2.0000	2.025	80T160S	80T160A
170	2.1250	2.150	80T170S	80T170A
180	2.2500	2.275	80T180S	80T180A
190	2.3750	2.400	80T190S	80T190A
200	2.5000	2.525	80T200S	80T200A
210	2.6250	2.650	80T210S	80T210A
220	2.7500	2.775	80T220S	80T220A

Other Bore Sizes Available. Consult Factory.

* Hob cuts into hub.

SPUR GEAR-96 PITCH — 1/16", 3/32", 1/8" Face Width ■ 20° Pressure Angle

Pin Hub — 1/8" Bore

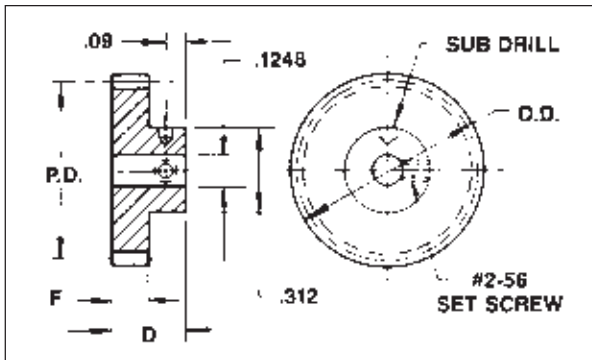

Material: 303 Stainless Steel
2024-T4 Aluminum
(Anodized Before Cutting)

Dimen.	Face Width		
	1/16"	3/32"	1/8"
D	.250	.281	.312
F	.062	.093	.125

Tolerances	Q10	Q12	Q14
Bore	+ .0005 - .0000	+ .0003 - .0000	+ .0002 - .0000
Pitch Diameter	+ .000 - .001	+ .0000 - .0007	+ .0000 - .0005
Outside Diameter	+ .000 - .002	+ .0000 - .0015	+ .000 - .001
Total Composite Tolerance	FOR AGMA QUALITY STANDARDS		
Tooth to Tooth Tolerance	SEE PAGE 12-2		

To order AGMA 12 Gears, add - Q12 to Part No.
To order AGMA 14 Gears, add - Q14 to Part No.

No. Teeth	Gear Data		Stainless Steel Part No. Face Width			Aluminum Part No. Face Width		
	P.D.	O.D.	1/16"	3/32"	1/8"	1/16"	3/32"	1/8"
34	.3541	.375	G51-34	G27-34	G29-34	G52-34	G28-34	G30-34
36	.3750	.396	G51-36	G27-36	G29-36	G52-36	G28-36	G30-36
38	.3958	.417	G51-38	G27-38	G29-38	G52-38	G28-38	G30-38
40	.4166	.438	G51-40	G27-40	G29-40	G52-40	G28-40	G30-40
44	.4583	.479	G51-44	G27-44	G29-44	G52-44	G28-44	G30-44
46	.4791	.500	G51-46	G27-46	G29-46	G52-46	G28-46	G30-46
48	.5000	.521	G51-48	G27-48	G29-48	G52-48	G28-48	G30-48
50	.5208	.542	G51-50	G27-50	G29-50	G52-50	G28-50	G30-50
52	.5416	.563	G51-52	G27-52	G29-52	G52-52	G28-52	G30-52
54	.5625	.583	G51-54	G27-54	G29-54	G52-54	G28-54	G30-54
56	.5833	.604	G51-56	G27-56	G29-56	G52-56	G28-56	G30-56
58	.6041	.625	G51-58	G27-58	G29-58	G52-58	G28-58	G30-58
60	.6250	.646	G51-60	G27-60	G29-60	G52-60	G28-60	G30-60
64	.6666	.688	G51-64	G27-64	G29-64	G52-64	G28-64	G30-64
72	.7500	.771	G51-72	G27-72	G29-72	G52-72	G28-72	G30-72
84	.8750	.896	G51-84	G27-84	G29-84	G52-84	G28-84	G30-84
96	1.0000	1.021	G51-96	G27-96	G29-96	G52-96	G28-96	G30-96
100	1.0416	1.063	G51-100	G27-100	G29-100	G52-100	G28-100	G30-100
108	1.1250	1.146	—	G27-108	G29-108	—	G28-108	G30-108
120	1.2500	1.271	—	—	G29-120	—	—	G30-120
127	1.3229	1.344	—	—	G29-127	—	—	G30-127
132	1.3750	1.396	—	—	G29-132	—	—	G30-132
144	1.5000	1.521	—	—	G29-144	—	—	G30-144
156	1.6250	1.646	—	—	G29-156	—	—	G30-156
168	1.7500	1.771	—	—	G29-168	—	—	G30-168
180	1.8750	1.896	—	—	G29-180	—	—	G30-180
192	2.0000	2.021	—	—	G29-192	—	—	G30-192
213	2.2187	2.240	—	—	G29-213	—	—	G30-213

Other Size Bores Available. Consult Factory

For gears with a number of teeth not shown within the range listed above, substitute the required number of teeth for the digits at the end of the Part Number.

Pricing can be determined by using our online E-Commerce price list for the next higher published part number in the listing.

SPUR GEAR-96 PITCH — 1/8" Face Width ■ 20° Pressure Angle

Split Hub — 1/8" Bore

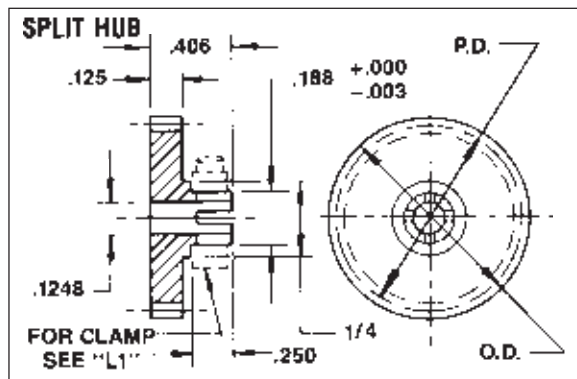

Tolerances	Q10	Q12	Q14
Bore	+ .0005 0.000	+ .0003 0.000	+ .0002 0.000
Pitch Diameter	+ .000 -.001	+ .0000 -.0007	+ .0000 -.0005
Outside Diameter	+ .000 -.002	+ .0000 -.0015	+ .000 -.001
Total Composite Tolerance	FOR AGMA QUALITY STANDARDS		
Tooth to Tooth Tolerance	SEE PAGE 12-2		

Gear Data			Stainless Steel Part No.		Aluminum Part No.	
No. Teeth	P.D.	O.D.				
32	3333	354	H7-32		HB-32	
34	3541	375	H7-34		HB-34	
35	3645	385	H7-35		HB-35	
36	3750	396	H7-36		HB-36	
38	3958	417	H7-38		HB-38	
40	4166	438	H7-40		HB-40	
44	4583	479	H7-44		HB-44	
48	5000	521	H7-48		HB-48	
50	5208	542	H7-50		HB-50	
52	5416	563	H7-52		HB-52	
54	5625	583	H7-54		HB-54	
56	5833	604	H7-56		HB-56	
58	6041	625	H7-58		HB-58	
60	6250	645	H7-60		HB-60	
64	6666	688	H7-64		HB-64	
77	7500	771	H7-72		HB-72	
84	8750	896	H7-84		HB-84	
96	1 0000	1 021	H7-96		HB-96	
100	1 0416	1 063	H7-100		HB-100	
108	1 1250	1 146	H7-108		HB-108	

Material: 303 Stainless Steel
2024-T4 Aluminum
(Anodized Before Cutting)

To order AGMA 12 Gears, add - Q12 to Part No.
To order AGMA 14 Gears, add - Q14 to Part No.

For gears with a number of teeth not shown within the range listed above, substitute the required number of teeth for the digits at the end of the Part Number.

Pricing can be determined by using our online E-Commerce price list for the next higher published part number in the listing.

Other Size Bores Available, Consult Factory

SPUR GEAR-96 PITCH — 1/16", 1/8" Face Width ■ 20° Pressure Angle

Hubless — 3/8" Bore

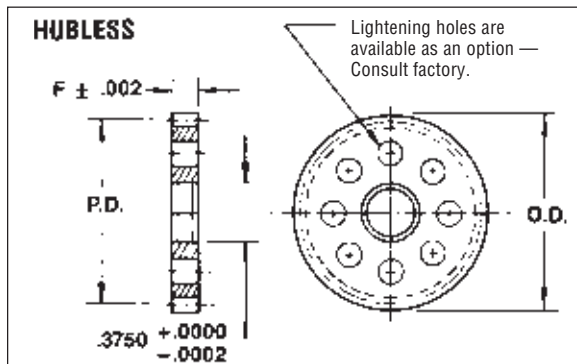

Tolerances	Q10	Q12	Q14
Pitch Diameter	+ .000 -.001	+ .0000 -.0007	+ .0000 -.0005
Outside Diameter	+ .000 -.002	+ .0000 -.0015	+ .000 -.001
Total Composite Tolerance	FOR AGMA QUALITY STANDARDS		
Tooth to Tooth Tolerance	SEE PAGE 12-2		

Gear Data			Stainless Steel Part No. Face Width		Aluminum Part No. Face Width	
No. Teeth	P.D.	O.D.	1/16"	1/8"	1/16"	1/8"
58	6041	625	J27-58	J7-58	J28-58	J8-58
59	6145	635	J27-59	J7-59	J28-59	J8-59
60	6250	646	J27-60	J7-60	J28-60	J8-60
61	6354	656	J27-61	J7-61	J28-61	J8-61
62	6458	667	J27-62	J7-62	J28-62	J8-62
63	6562	677	J27-63	J7-63	J28-63	J8-63
64	6666	688	J27-64	J7-64	J28-64	J8-64
65	6770	698	J27-65	J7-65	J28-65	J8-65
66	6875	708	J27-66	J7-66	J28-66	J8-66
72	7500	771	J27-72	J7-72	J28-72	J8-72
84	8750	896	J27-84	J7-84	J28-84	J8-84
96	1 0000	1 021	J27-96	J7-96	J28-96	J8-96
100	1 0416	1 063	J27-100	J7-100	J28-100	J8-100
108	1 1250	1 146	J27-108	J7-108	J28-108	J8-108
116	1 2083	1 229	J27-116	J7-116	J28-116	J8-116
120	1 2500	1 271	J27-120	J7-120	J28-120	J8-120
127	1 3279	1 344	J27-127	J7-127	J28-127	J8-127
132	1 3750	1 396	J27-132	J7-132	J28-132	J8-132
144	1 5000	1 521	J27-144	J7-144	J28-144	J8-144
156	1 6250	1 648	J27-156	J7-156	J28-156	J8-156
168	1 7500	1 771	J27-168	J7-168	J28-168	J8-168
180	1 8750	1 896	J27-180	J7-180	J28-180	J8-180
192	2 0000	2 021	J27-192	J7-192	J28-192	J8-192
216	2 2500	2 271	J27-216	J7-216	J28-216	J8-216
228	2 3750	2 396	J27-228	J7-228	J28-228	J8-228
240	2 5000	2 521	—	J7-240	—	J8-240
264	2 7500	2 771	—	J7-264	—	J8-264
288	3 0000	3 021	—	J7-288	—	J8-288
336	3 5000	3 521	—	J7-336	—	J8-336
384	4 0000	4 021	—	J7-384	—	J8-384

Material: 303 Stainless Steel
2024-T4 Aluminum
(Anodized Before Cutting)

To order AGMA 12 Gears, add - Q12 to Part No.
To order AGMA 14 Gears, add - Q14 to Part No.

Dimen.	Face Width	
	1/16"	1/8"
F	062	125

For gears with a number of teeth not shown within the range listed above, substitute the required number of teeth for the digits at the end of the Part Number.

Pricing can be determined by using our online E-Commerce price list for the next higher published part number in the listing.

For Gear Hubs See Pages 12-67 & 12-68

Other Size Bores Available, Consult Factory.

SPUR GEAR-120 PITCH — 1/16", 3/32", 1/8" Face Width ■ 20° Pressure Angle

Pin Hub — 1/8" Bore ■ Hubless 3/8" Bore

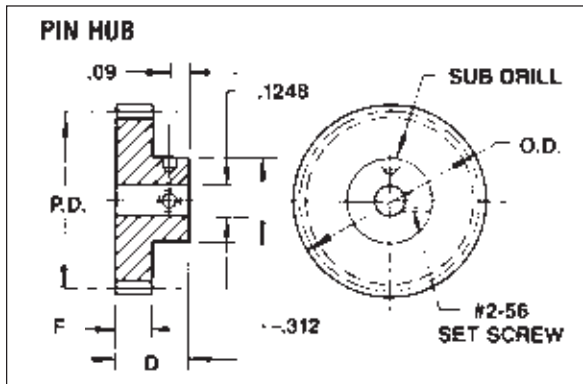

Dimen.	Face Width	
	1/16	3/32
D	.250	.281
F	.062	.093

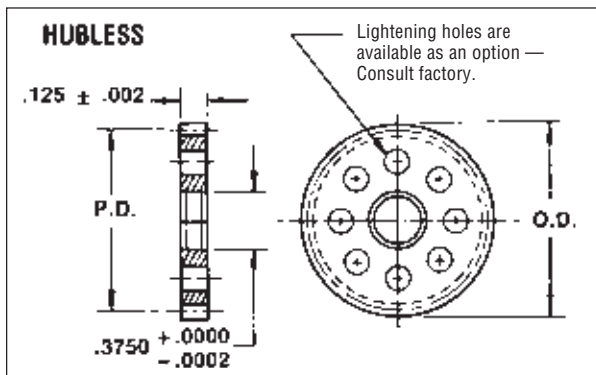

Gear Data			Stainless Steel Part No. Face Width		Aluminum Part No. Face Width			
No. Teeth	P.O.	O.D.	Pin Hub		Hubless	Pin Hub		Hubless
			1/16"	3/32"	1/8"	1/16"	3/32"	1/8"
42	.3500	.367	G55-42	G35-42	—	G56-42	G36-42	—
45	.3750	.392	G55-45	G35-45	—	G56-45	G36-45	—
48	.4000	.417	G55-48	G35-48	—	G56-48	G36-48	—
54	.4500	.467	G55-54	G35-54	—	G56-54	G36-54	—
60	.5000	.517	G55-60	G35-60	—	G56-60	G36-60	—
66	.5500	.567	G55-66	G35-66	—	G56-66	G36-66	—
72	.6000	.617	G55-72	G35-72	J9-72	G56-72	G36-72	J10-72
78	.6500	.667	G55-78	G35-78	J9-78	G56-78	G36-78	J10-78
84	.7000	.717	G55-84	G35-84	J9-84	G56-84	G36-84	J10-84
90	.7500	.767	G55-90	G35-90	J9-90	G56-90	G36-90	J10-90
96	.8000	.817	G55-96	G35-96	J9-96	G56-96	G36-96	J10-96
102	.8500	.867	G55-102	G35-102	J9-102	G56-102	G36-102	J10-102
108	.9000	.917	G55-108	G35-108	J9-108	G56-108	G36-108	J10-108
114	.9500	.967	G55-114	G35-114	J9-114	G56-114	G36-114	J10-114
120	1.0000	1.017	G55-120	G35-120	J9-120	G56-120	G36-120	J10-120
126	1.0500	1.067	G55-126	G35-126	J9-126	G56-126	G36-126	J10-126
127	1.0583	1.075	G55-127	G35-127	J9-127	G56-127	G36-127	J10-127
132	1.1000	1.117	G55-132	G35-132	J9-132	G56-132	G36-132	J10-132
138	1.1500	1.167	—	G35-138	J9-138	—	G36-138	J10-138
144	1.2000	1.217	—	G35-144	J9-144	—	G36-144	J10-144
150	1.2500	1.267	—	G35-150	J9-150	—	G36-150	J10-150
156	1.3000	1.317	—	G35-156	J9-156	—	G36-156	J10-156
162	1.3500	1.367	—	G35-162	J9-162	—	G36-162	J10-162
168	1.4000	1.417	—	—	J9-168	—	—	J10-168
174	1.4500	1.467	—	—	J9-174	—	—	J10-174
180	1.5000	1.517	—	—	J9-180	—	—	J10-180

Other Size Bore Available Consult Factory.

For Gear Hubs See Pages 12-67 & 12-68

Material: 303 Stainless Steel
2024-T4 Aluminum
(Anodized Before Cutting)

Tolerances	Q10	Q12	Q14
Bore	+ .0005 - .0000	+ .0003 - .0000	+ .0002 - .0000
Pitch Diameter	+ .000 - .001	+ .0000 - .0007	+ .0000 - .0005
Outside Diameter	+ .000 - .002	+ .0000 - .0015	+ .000 - .001
Total Composite Tolerance	FOR AGMA QUALITY STANDARDS		
Tooth to Tooth Tolerance	SEE PAGE 12-2		

To order AGMA 12 Gears, add - Q12 to Part No.
To order AGMA 14 Gears, add - Q14 to Part No.

For gears with a number of teeth not shown within the range listed above, substitute the required number of teeth for the digits at the end of the Part Number.

Pricing can be determined by using our online E-Commerce price list for the next higher published part number in the listing.

PRECISION PINION SHAFTS — 1/8", 3/16", 1/4" Shaft Diameter ■ 3/16" Face Width

20° Pressure Angle ■ Agma Quality No. 10 ■ P.D. Less Than Shaft Diameter

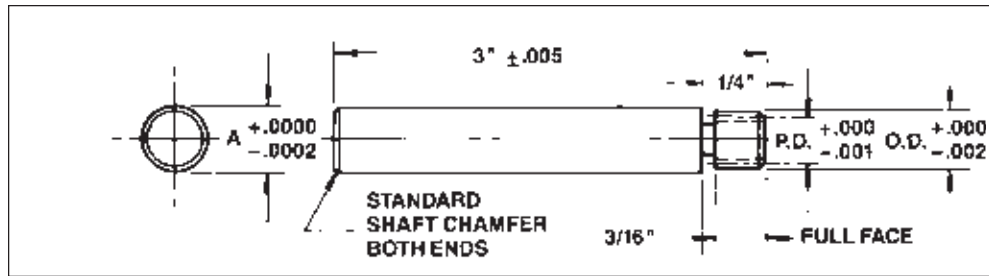

Material: 303 Stainless Steel

A	Pitch	No. Teeth	P. D.	O. D.	Part No.
1247 (1/8)	96	10	.1042	.125	F4-1
	120	12	.1000	.116	F4-2
	200	18	.0900	.100	F4-3
	200	20	.1000	.110	F4-4
.1872 (3/16)	72	10	.1388	.166	F5-1
	80	10	.1250	.150	F5-6
	96	10	.1042	.125	F5-2
	96	12	.1250	.146	F5-4
	96	14	.1458	.168	F5-5

A	Pitch	No. Teeth	P. D.	O. D.	Part No.
2497 (1/4)	48	10	.2083	.250	F6-1
	54	12	.1875	.219	F6-2
	64	14	.2187	.250	F6-3
	72	14	.1944	.222	F6-4
	72	15	.2222	.250	F6-5
	80	10	.1250	.150	F6-8
	80	12	.1500	.175	F6-9
	96	16	.1666	.187	F6-6
96	18	.1875	.208	F6-7	

Other Lengths and/or Teeth Available. Consult Factory
Centers at PIC option

PRECISION PINION SHAFTS — 1/8", 3/16", 1/4" Shaft Diameter ■ 3/16" Face Width

20° Pressure Angle ■ Agma Quality No. 10 ■ P.D. Greater Than Shaft Diameter

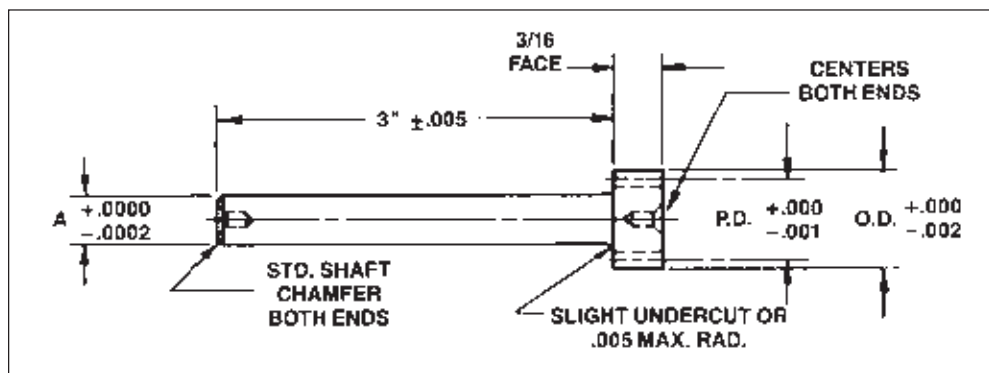

Material: 303 Stainless Steel

A	Pitch	No. Teeth	P. D.	O. D.	Part No.
1247 (1/8)	64	18	.2500	.281	*F7-1
	96	24	.2500	.271	*F7-6
.1872 (3/16)	48	12	.2500	.291	*F8-1
	48	18	.3750	.416	*F8-2
	64	16	.2500	.281	*F8-3
	72	18	.2500	.278	*F8-5
	80	20	.2500	.275	*F8-7

A	Pitch	No. Teeth	P. D.	O. D.	Part No.
2497 (1/4)	24	12	5000	580	F9-1
	30	16	5000	560	F9-2
.1872 (3/16)	48	12	2500	291	F9-3
	48	18	3750	416	F9-4
	64	16	2500	281	F9-5
	64	20	2125	340	F9-6
	64	24	3750	406	F9-7
	110	10	2125	3820	F9-8

Other Lengths and/or Teeth Available. Consult Factory.
Centers at PIC option

*Q12 and Q14 Tolerances Available on Request.

FINE PITCH RACK DATA — 24 to 120 Pitch

Terminology

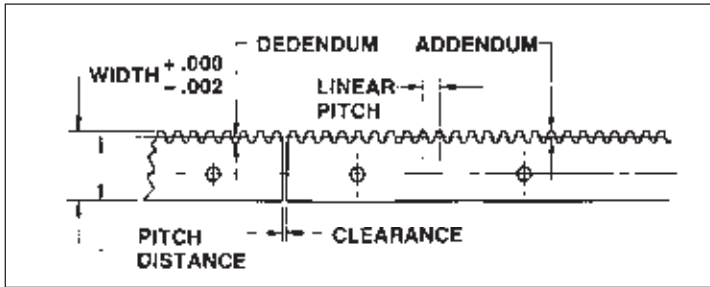

AVAILABLE PITCHES AND TOOTH DATA

Pitch	Linear Pitch	Addendum	Dedendum	Whole Depth
24	.1309	.0417	.0520	.0937
1/10	1.000	.0318	.0402	.0720
32	.0982	.0313	.0395	.0708
48	.0654	.0208	.0270	.0478
64	.0491	.0156	.0208	.0364
72	.0436	.0139	.0187	.0326
80	.0393	.0125	.0170	.0295
96	.0327	.0104	.0145	.0249
120	.0262	.0083	.0120	.0203

MATERIALS

Standard: 416 Stainless-Stress relieved, not heat treated
2024-T4 Aluminum (Anodized).

Available on Request: Stainless, Carbon & Alloy Steels,
Non-Ferrous & Non-Metallic Materials.

FINISHES

Hardened, Nitrided, Anodizes.

LENGTHS

Available Up To 36"

FACE WIDTHS

Available Up To 2"

PIC CLASSIFICATIONS AND TOLERANCES

PIC Class Rack	MAXIMUM SPACING ERROR		Parallelism To Base
	Tooth-to-Tooth	Accumulated in 11"	
PREC. 1	.0005	.002	.001
PREC. 2	.0004	.001	.0007
PREC. 3	.0002	.0006	.0005

FINE PITCH RACK DATA — 24 to 96 Pitch

20° Pressure Angle ■ PIC Prec. 1, 2, 3

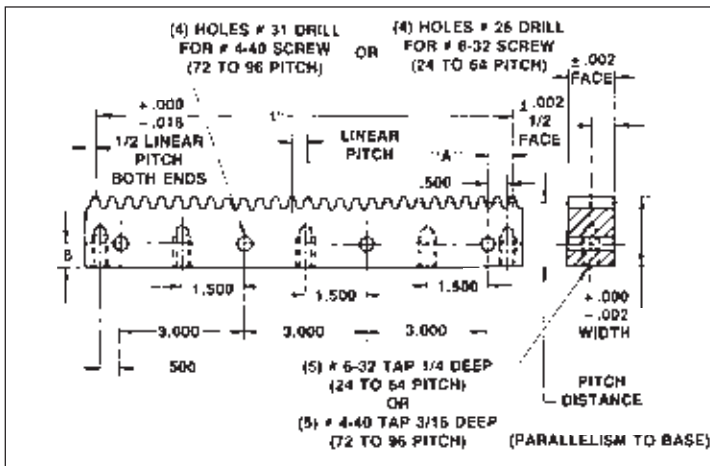

Material:
416 Stainless Steel
Stress Relieved
Ground on all Sides

RACK DATA								Part No.
Pitch	L	Pitch Distance	Face	Width	Linear Pitch	A	B	
24	10.9956	.4383	.230	.480	.1309	.998	.218	AG-31
1/10	10.9000	.4482	.230	.480	1.000	.950	.218	AG-32
32	10.9956	.4482	.230	.480	.0982	.998	.218	AG-33
48	10.9956	.4592	.230	.480	.0654	.998	.218	AG-34
64	10.9956	.4644	.230	.480	.0491	.998	.218	AG-35
72	10.9956	.3411	.167	.355	.0436	.998	.156	AG-36
96	10.9956	.3446	.167	.355	.0327	.998	.156	AG-38

To order PREC. 2 Racks, add-P2 to Part No.
To order PREC. 3 Racks, add-P3 to Part No.

Tolerances	P1	P2	P3
Pitch Distance	+ .000 - .001	+ .0000 - .0007	+ .0000 - .0005
Tooth to Tooth	.0005	.0004	.0002
Total Composite	.002	.001	.0006

Total Composite - Max. Spacing Error Accumulated in 11"

FINE PITCH RACKS — 24 to 120 Pitch ■ 20° Pressure Angle

3" to 10" Lengths ■ PIC Prec. 1

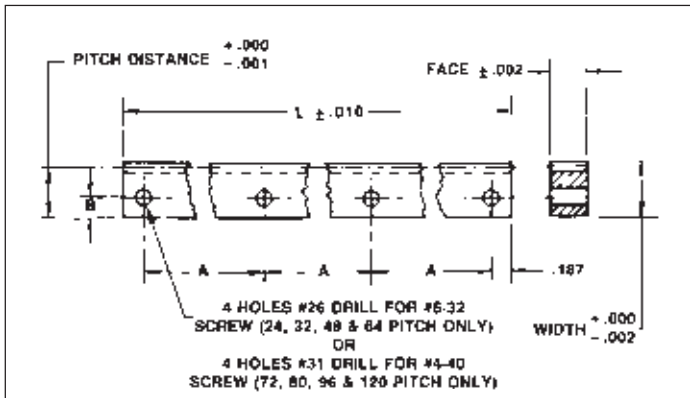

Material: 416 Stainless Steel
2024-T4 Aluminum (Anodized)

Pitch	L	Pitch Distance	Face	Width	A	B	Material	Part No.
24	10	.4383	.230	.480	3.208	.218	Stainless Aluminum	AG-9 AG-100
32	10	.4487	.230	.480	3.208	.218	Stainless Aluminum	AG-110 AG-120
48	9	.4592	.230	.480	2.875	.218	Stainless Aluminum	AG-1 AG-2
64	7	.4644	.230	.480	2.208	.218	Stainless Aluminum	AG-3 AG-4
72	5	.3411	.167	.355	1.541	.156	Stainless Aluminum	AG-5 AG-6
80	5	.3425	.167	.355	1.541	.156	Stainless Aluminum	AG-130 AG-140
96	3	.3446	.167	.355	.875	.156	Stainless Aluminum	AG-7 AG-8
120	3	.3467	.167	.355	.875	.156	Stainless Aluminum	AG-150 AG-160

For Longer Racks, See AG-31 to AG-36

FINE PITCH RACKS — 24 to 120 Pitch ■ 20° Pressure Angle

Rectangular Stock ■ PIC Prec. 1

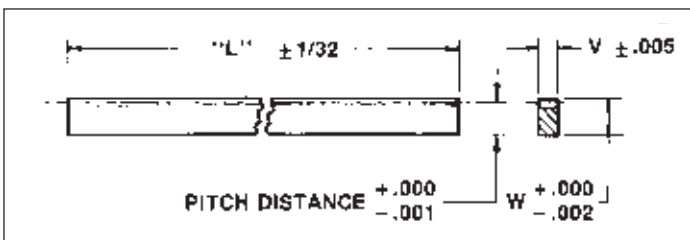

Material: 416 Stainless Steel *

*Available in Delrin with P.D. & W tolerance of $\begin{matrix} +.000 \\ -.005 \end{matrix}$
Part Numbers: AG-10D, AG-11D, AG-12D, AG-13D

Pitch	L	Pitch Distance	V	W	Part No.
24	18	.438	.230	.480	AG-10*
32	18	.449	.230	.480	AG-11*
48	18	.459	.230	.480	AG-12*
64	11	.464	.230	.480	AG-13*
72	11	.341	.167	.355	AG-14
96	11	.344	.167	.355	AG-15
120	11	.347	.167	.355	AG-16

FINE PITCH RACKS — 24 to 120 Pitch ■ 20° Pressure Angle

Round Stock ■ PIC Prec. 1

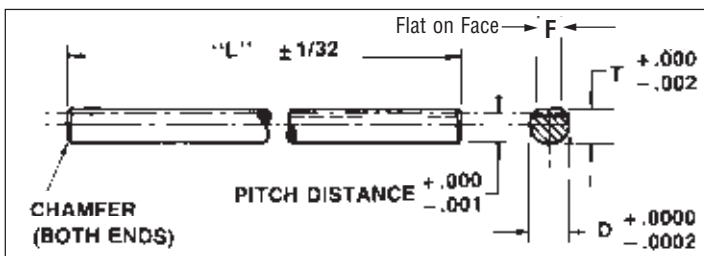

Material: 416 Stainless Steel *

*Available in Delrin with P.D. & T tolerance of $\begin{matrix} +.000 \\ -.005 \end{matrix}$ and D tolerance of $\begin{matrix} +.002 \\ -.000 \end{matrix}$
Part Number: AG-17D

Pitch	L	Pitch Distance	F	D	T	Part No.
24	18	.438	3/16	.4997	.480	AG-17*
32	18	.309	3/16	.3747	.340	AG-18
48	18	.199	5/32	.2497	.220	AG-19
64	11	.204	5/32	.2497	.220	AG-20
72	11	.142	1/8	.1872	.156	AG-21
96	11	.145	1/8	.1872	.156	AG-22
120	11	.107	3/32	.1247	.115	AG-23

DELTRIN® SPUR GEAR-24 PITCH — 3/16" Face Width ■ 20° Pressure Angle

Stainless Steel Pin Hub — 3/16", 1/4" Bores ■ Hubless — 3/8" Bore

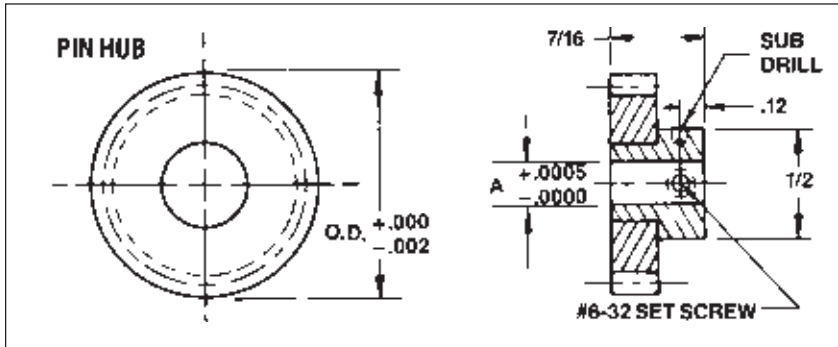

Dimen.	Bore	
	3/16	1/4
A	.1873	.2498

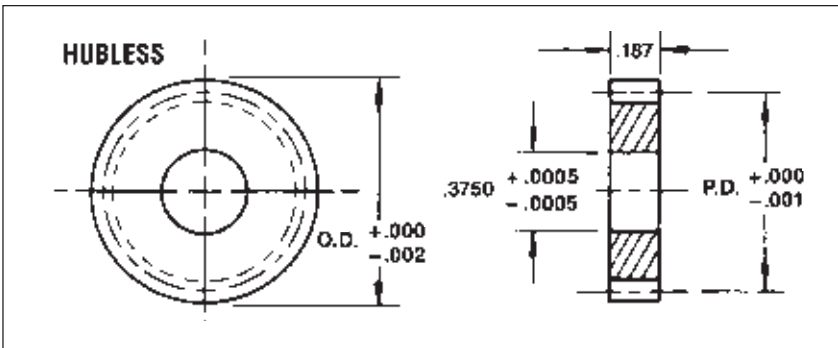

Gear — Acetal (Delrin® or Celcon®)
Hub — 303 Stainless Steel

For gears with a number of teeth not shown within the range listed above, substitute the required number of teeth for the digits at the end of the Part Number.

Pricing can be determined by using our online E-Commerce price list for the next higher published part number in the listing.

No. Teeth	Gear Data		Pin Hub Part No. Bore Size		Hubless Part No. Bore Size
	P.D.	O.D.	.1873	.2498	.3750
15	.6250	.708	AB14-15	AB15-15	AB13-15
16	.6667	.750	AB14-16	AB15-16	AB13-16
17	.7083	.792	AB14-17	AB15-17	AB13-17
18	.7500	.833	AB14-18	AB15-18	AB13-18
19	.7917	.875	AB14-19	AB15-19	AB13-19
20	.8333	.917	AB14-20	AB15-20	AB13-20
21	.8750	.958	AB14-21	AB15-21	AB13-21
22	.9167	1.000	AB14-22	AB15-22	AB13-22
23	.9583	1.042	AB14-23	AB15-23	AB13-23
24	1.0000	1.083	AB14-24	AB15-24	AB13-24
25	1.0417	1.125	AB14-25	AB15-25	AB13-25
26	1.0833	1.167	AB14-26	AB15-26	AB13-26
27	1.1250	1.208	AB14-27	AB15-27	AB13-27
28	1.1667	1.250	AB14-28	AB15-28	AB13-28
29	1.2083	1.292	AB14-29	AB15-29	AB13-29
30	1.2500	1.333	AB14-30	AB15-30	AB13-30
31	1.2917	1.375	AB14-31	AB15-31	AB13-31
32	1.3333	1.417	AB14-32	AB15-32	AB13-32
33	1.3750	1.458	AB14-33	AB15-33	AB13-33
34	1.4167	1.500	AB14-34	AB15-34	AB13-34
35	1.4583	1.542	AB14-35	AB15-35	AB13-35
36	1.5000	1.583	AB14-36	AB15-36	AB13-36
37	1.5417	1.625	AB14-37	AB15-37	AB13-37
38	1.5833	1.667	AB14-38	AB15-38	AB13-38
39	1.6250	1.708	AB14-39	AB15-39	AB13-39
40	1.6667	1.750	AB14-40	AB15-40	AB13-40
41	1.7083	1.792	AB14-41	AB15-41	AB13-41
42	1.7500	1.833	AB14-42	AB15-42	AB13-42
43	1.7917	1.875	AB14-43	AB15-43	AB13-43
44	1.8333	1.917	AB14-44	AB15-44	AB13-44
45	1.8750	1.958	AB14-45	AB15-45	AB13-45
46	1.9167	2.000	AB14-46	AB15-46	AB13-46
47	1.9583	2.042	AB14-47	AB15-47	AB13-47
48	2.0000	2.083	AB14-48	AB15-48	AB13-48
49	2.0417	2.125	AB14-49	AB15-49	AB13-49
50	2.0833	2.167	AB14-50	AB15-50	AB13-50
51	2.1250	2.208	AB14-51	AB15-51	AB13-51
52	2.1667	2.250	AB14-52	AB15-52	AB13-52
53	2.2083	2.292	AB14-53	AB15-53	AB13-53
54	2.2500	2.333	AB14-54	AB15-54	AB13-54
55	2.2917	2.375	AB14-55	AB15-55	AB13-55
56	2.3333	2.417	AB14-56	AB15-56	AB13-56
57	2.3750	2.458	AB14-57	AB15-57	AB13-57
58	2.4167	2.500	AB14-58	AB15-58	AB13-58
59	2.4583	2.542	AB14-59	AB15-59	AB13-59
60	2.5000	2.583	AB14-60	AB15-60	AB13-60
61	2.5417	2.625	AB14-61	AB15-61	AB13-61
62	2.5833	2.667	AB14-62	AB15-62	AB13-62
63	2.6250	2.708	AB14-63	AB15-63	AB13-63
64	2.6667	2.750	AB14-64	AB15-64	AB13-64
65	2.7083	2.792	AB14-65	AB15-65	AB13-65
66	2.7500	2.833	AB14-66	AB15-66	AB13-66
67	2.7917	2.875	AB14-67	AB15-67	AB13-67
68	2.8333	2.917	AB14-68	AB15-68	AB13-68
69	2.8750	2.958	AB14-69	AB15-69	AB13-69

Other Size Bores Available, Consult Factory.

For Gear Hubs See Pages 12-67 & 12-68

DELTRIN® SPUR GEAR-32 PITCH — 3/16" Face Width ■ 20° Pressure Angle

Stainless Steel Pin Hub — 3/16", 1/4" Bores ■ Hubless — 3/8" Bore

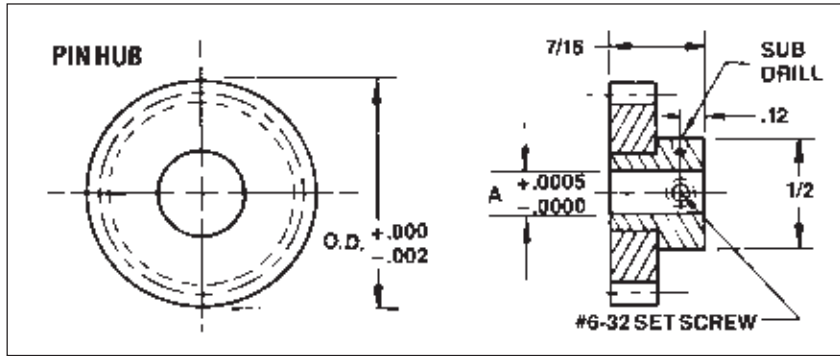

Dimen.	Bore	
	3/16	1/4
A	.1673	.2498

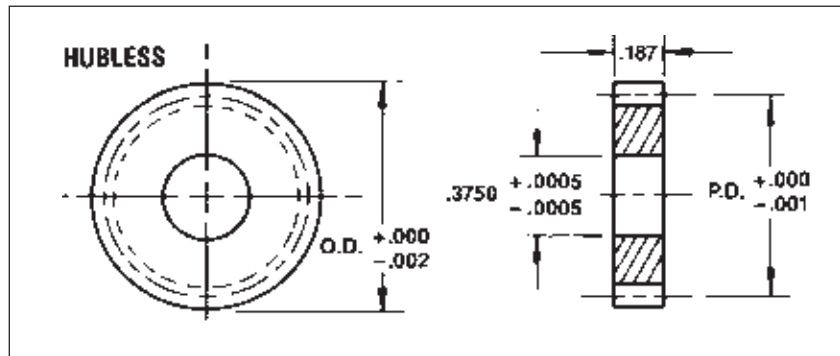

No. Teeth	Gear Data		Pin Hub Part No. Bore Size		Hubless Part No. Bore Size
	P.D.	O.D.	.1673	.2498	.3750
20	.6250	.688	AB17-20	AB18-20	AB16-20
21	.6563	.719	AB17-21	AB18-21	AB16-21
22	.6875	.750	AB17-22	AB18-22	AB16-22
23	.7188	.781	AB17-23	AB18-23	AB16-23
24	.7500	.813	AB17-24	AB18-24	AB16-24
25	.7813	.844	AB17-25	AB18-25	AB16-25
26	.8125	.875	AB17-26	AB18-26	AB16-26
28	.8750	.938	AB17-28	AB18-28	AB16-28
30	.9375	1.000	AB17-30	AB18-30	AB16-30
32	1.0000	1.063	AB17-32	AB18-32	AB16-32
36	1.1250	1.188	AB17-36	AB18-36	AB16-36
40	1.2500	1.313	AB17-40	AB18-40	AB16-40
42	1.3125	1.375	AB17-42	AB18-42	AB16-42
44	1.3750	1.438	AB17-44	AB18-44	AB16-44
46	1.4375	1.500	AB17-46	AB18-46	AB16-46
48	1.5000	1.563	AB17-48	AB18-48	AB16-48
50	1.5625	1.625	AB17-50	AB18-50	AB16-50
52	1.6250	1.688	AB17-52	AB18-52	AB16-52
55	1.7500	1.813	AB17-55	AB18-55	AB16-55
60	1.8750	1.938	AB17-60	AB18-60	AB16-60
63	1.9688	2.031	AB17-63	AB18-63	AB16-63
64	2.0000	2.063	AB17-64	AB18-64	AB16-64
66	2.0625	2.125	AB17-66	AB18-66	AB16-66
69	2.1563	2.219	AB17-69	AB18-69	AB16-69
72	2.2500	2.313	AB17-72	AB18-72	AB16-72
75	2.3438	2.406	AB17-75	AB18-75	AB16-75
80	2.5000	2.563	AB17-80	AB18-80	AB16-80
84	2.6250	2.688	AB17-84	AB18-84	AB16-84
88	2.7500	2.813	AB17-88	AB18-88	AB16-88
92	2.8750	2.938	AB17-92	AB18-92	AB16-92

Other Size Bores Available. Consult Factory

For Gear Hubs See Pages 12-67 & 12-68

Material:

Gear — Acetal (Delrin® or Celcon®)
Hub — 303 Stainless Steel

For gears with a number of teeth not shown within the range listed above, substitute the required number of teeth for the digits at the end of the Part Number.

Pricing can be determined by using our online E-Commerce price list for the next higher published part number in the listing.

DELRIN® SPUR GEAR-48 PITCH — 3/16" Face Width ■ 20° Pressure Angle

Stainless Steel Pin Hub — 3/16", 1/4" Bores ■ Hubless — 3/8" Bore

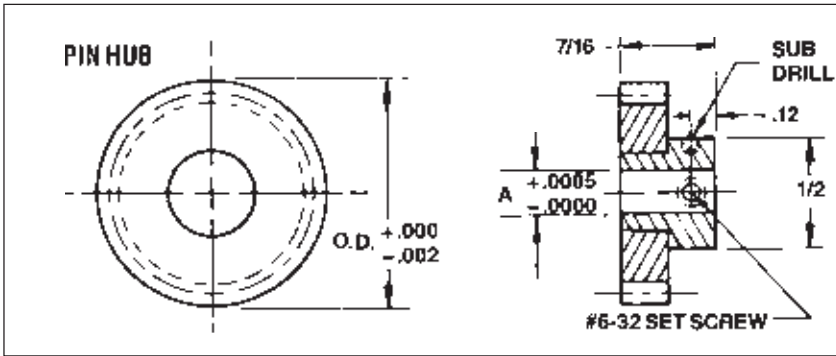

Dimen.	Bore	
	3/16	1/4
A	1873	2498

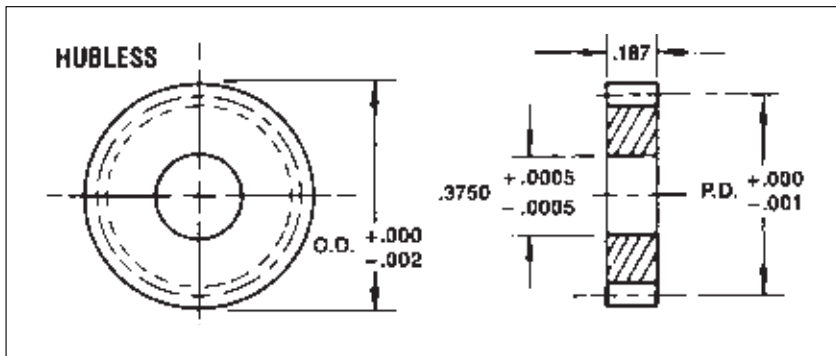

No. Teeth	Gear Data		Pin Hub Part No. Bore Size		Hubless Part No. Bore Size
	P.D.	O.D.	.1873	.2498	.3750
28	.5833	.625	AB20-28	AB21-28	AB19-28
29	.6041	.646	AB20-29	AB21-29	AB19-29
30	.6250	.667	AB20-30	AB21-30	AB19-30
32	.6666	.708	AB20-32	AB21-32	AB19-32
34	.7083	.750	AB20-34	AB21-34	AB19-34
36	.7500	.792	AB20-36	AB21-36	AB19-36
38	.7916	.833	AB20-38	AB21-38	AB19-38
40	.8333	.875	AB20-40	AB21-40	AB19-40
42	.8750	.917	AB20-42	AB21-42	AB19-42
44	.9166	.958	AB20-44	AB21-44	AB19-44
46	.9583	1.000	AB20-46	AB21-46	AB19-46
48	1.0000	1.042	AB20-48	AB21-48	AB19-48
50	1.0416	1.083	AB20-50	AB21-50	AB19-50
55	1.1458	1.188	AB20-55	AB21-55	AB19-55
56	1.1666	1.208	AB20-56	AB21-56	AB19-56
60	1.2500	1.292	AB20-60	AB21-60	AB19-60
64	1.3333	1.375	AB20-64	AB21-64	AB19-64
68	1.4166	1.458	AB20-68	AB21-68	AB19-68
72	1.5000	1.542	AB20-72	AB21-72	AB19-72
75	1.5625	1.604	AB20-75	AB21-75	AB19-75
80	1.6666	1.708	AB20-80	AB21-80	AB19-80
84	1.7500	1.792	AB20-84	AB21-84	AB19-84
90	1.8750	1.917	AB20-90	AB21-90	AB19-90
92	1.9166	1.958	AB20-92	AB21-92	AB19-92
96	2.0000	2.042	AB20-96	AB21-96	AB19-96
100	2.0833	2.125	AB20-100	AB21-100	AB19-100
110	2.2916	2.333	AB20-110	AB21-110	AB19-110
120	2.5000	2.542	AB20-120	AB21-120	AB19-120
132	2.7500	2.792	AB20-132	AB21-132	AB19-132
138	2.8750	2.917	AB20-138	AB21-138	AB19-138

Other Size Bores Available, Consult Factory

For Gear Hubs See Pages 12-67 & 12-68

Material:

Gear — Acetal (Delrin® or Celcon®)
Hub — 303 Stainless Steel

For gears with a number of teeth not shown within the range listed above, substitute the required number of teeth for the digits at the end of the Part Number.

Pricing can be determined by using our online E-Commerce price list for the next higher published part number in the listing.

DELTRIN® SPUR GEAR-64 PITCH — 3/16" Face Width ■ 20° Pressure Angle

Stainless Steel Pin Hub — 3/16", 1/4" Bores ■ Hubless — 3/8" Bore

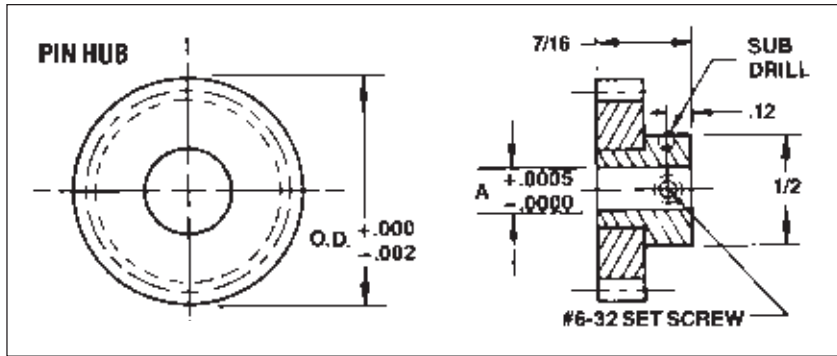

Dimen.	Bore	
	3/16	1/4
A	.1873	.2498

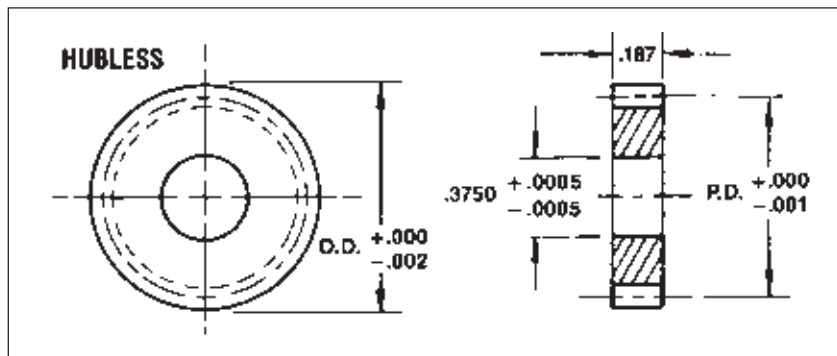

Material:

Gear — Acetal (Delrin® or Celcon®)
Hub — 303 Stainless Steel

For gears with a number of teeth not shown within the range listed above, substitute the required number of teeth for the digits at the end of the Part Number.

Pricing can be determined by using our online E-Commerce price list for the next higher published part number in the listing.

Gear Data			Pin Hub Part No. Bore Size		Hubless Part No. Bore Size
No. Teeth	P.D.	O.D.	.1873	.2498	.3750
36	.5625	.594	AB23-36	AB24-36	AB22-36
37	.5781	.609	AB23-37	AB24-37	AB22-37
38	.5937	.625	AB23-38	AB24-38	AB22-38
40	.6250	.656	AB23-40	AB24-40	AB22-40
42	.6562	.688	AB23-42	AB24-42	AB22-42
44	.6875	.719	AB23-44	AB24-44	AB22-44
46	.7187	.750	AB23-46	AB24-46	AB22-46
48	.7500	.781	AB23-48	AB24-48	AB22-48
50	.7812	.813	AB23-50	AB24-50	AB22-50
56	.8750	.906	AB23-56	AB24-56	AB22-56
60	.9375	.969	AB23-60	AB24-60	AB22-60
64	1.0000	1.031	AB23-64	AB24-64	AB22-64
72	1.1250	1.156	AB23-72	AB24-72	AB22-72
74	1.1562	1.188	AB23-74	AB24-74	AB22-74
80	1.2500	1.281	AB23-80	AB24-80	AB22-80
84	1.3125	1.344	AB23-84	AB24-84	AB22-84
88	1.3750	1.406	AB23-88	AB24-88	AB22-88
90	1.4062	1.438	AB23-90	AB24-90	AB22-90
96	1.5000	1.531	AB23-96	AB24-96	AB22-96
100	1.5625	1.594	AB23-100	AB24-100	AB22-100
112	1.7500	1.781	AB23-112	AB24-112	AB22-112
120	1.8750	1.906	AB23-120	AB24-120	AB22-120
127	1.9843	2.016	AB23-127	AB24-127	AB22-127
128	2.0000	2.031	AB23-128	AB24-128	AB22-128
144	2.2500	2.281	AB23-144	AB24-144	AB22-144

Other Size Bores Available. Consult Factory.

For Gear Hubs See Pages 12-67 & 12-68

PRECISION CLUSTER GEARS

AGMA 10

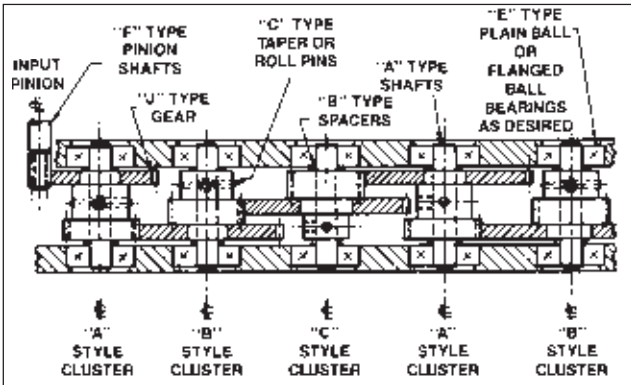

The following PIC cluster gears have been designed to allow large gear reduction. Quickly assembled with minimum space requirements.

For continuous reductions always follow sequence of meshing, "A" style cluster with "B" style cluster with "C" style cluster

— Then repeat sequence for desired ratio

RECOMMENDATIONS

- (1) Mesh stainless pinions with aluminum gears
Always reduce pitch and increase shaft size as ratio and torque increase.
- (2) Select "J" type gears as required for assembly to cluster gear hubs as to pitch, number of teeth and material.
Always make a check layout to be sure gears do not run into adjacent hubs with correct center distances.
- (3) Center Distances — To select proper center distances see Technical Section of this Catalog.

CLUSTER GEARS & HUBS — AGMA 10

20° Pressure Angle ■ 3/16" Bore

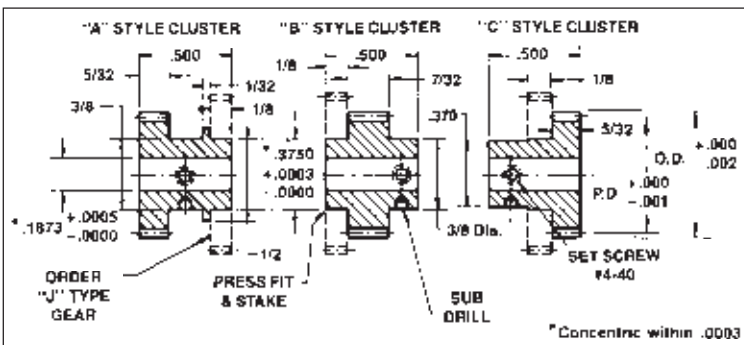

Material: 303 Stainless Steel

Pitch	No. Teeth	P.D.	O.D.	Part Number		
				"A" STYLE	"B" STYLE	"C" STYLE
48	20	4166	458	CO-1	CO-8	CO-15
	21	4375	479	CO-23	CO-30	CO-37
	22	4583	500	CO-24	CO-31	CO-38
	23	4791	521	CO-25	CO-32	CO-39
	24	5000	542	CO-26	CO-33	CO-40
	25	5206	563	CO-2	CO-9	CO-16
	26	5416	583	CO-27	CO-34	CO-41
	27	5625	604	CO-28	CO-35	CO-42
	28	5833	625	CO-29	CO-36	CO-43
	29	6040	646	CO-30	CO-37	CO-44
64	30	6250	666	CO-3	CO-10	CO-17
	31	6458	687	CO-31	CO-38	CO-45
	32	6666	708	CO-32	CO-39	CO-46
	33	6875	729	CO-33	CO-40	CO-47

For other pitches, bore sizes or modifications, consult factory

CLUSTER GEARS & HUBS — AGMA 10

20° Pressure Angle ■ 1/4" Bore

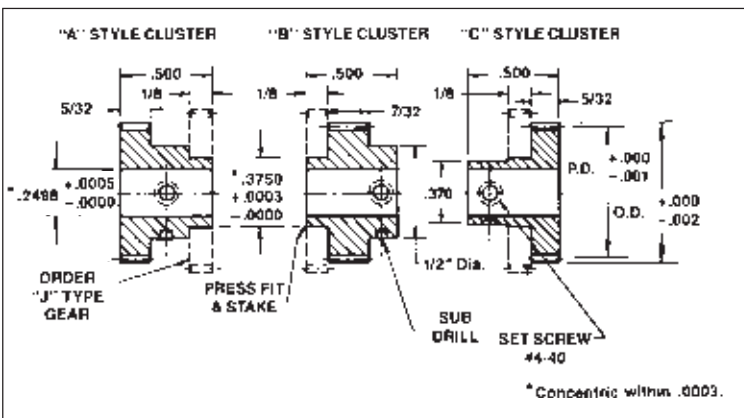

Material: 303 Stainless Steel

Pitch	No. Teeth	P.D.	O.D.	Part Number			
				"A" STYLE	"B" STYLE	"C" STYLE	
48	20	4166	458	CN-32	CN-95	CN-156	
	21	4375	479	CN-33	CN-96	CN-159	
	22	4583	500	CN-34	CN-97	CN-160	
	23	4791	521	CN-35	CN-98	CN-161	
	24	5000	542	CN-36	CN-99	CN-162	
	25	5206	563	CN-1	CN-6	CN-15	
	26	5416	583	CN-37	CN-100	CN-163	
	28	5833	625	CN-38	CN-101	CN-164	
	30	6250	666	CN-2	CN-9	CN-16	
	32	6666	708	CN-39	CN-102	CN-165	
	64	27	4218	453	CN-40	CN-103	CN-166
		28	4375	489	CN-41	CN-104	CN-167
30		4687	500	CN-42	CN-105	CN-168	
32		5000	531	CN-43	CN-106	CN-169	
34		5312	563	CN-44	CN-107	CN-170	
36		5625	594	CN-45	CN-108	CN-171	
38		5937	625	CN-46	CN-109	CN-172	
40		6250	656	CN-3	CN-10	CN-17	
42		6562	688	CN-47	CN-110	CN-173	
44		6875	719	CN-48	CN-111	CN-174	

For other pitches, bore sizes or modifications, consult factory

ANTI-BACKLASH GEAR-24 PITCH — 3/16" Face Width ■ 20° Pressure Angle

Interchangeable Design ■ Pin Hub — 1/4" Bores

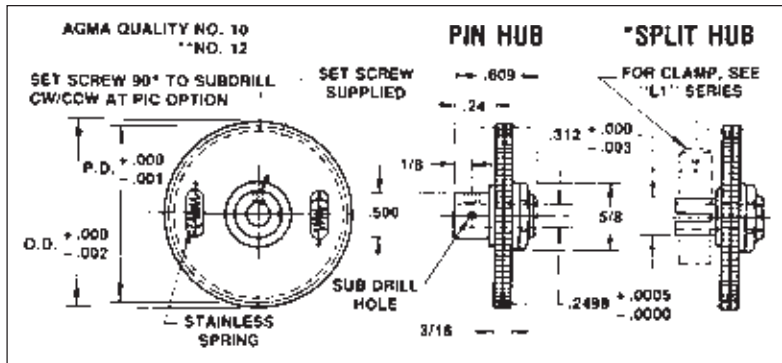

Material:

- Gears — 303 Stainless Steel
- 2024-T4 Aluminum
- (Anodized Before Cutting)
- Hubs — 303 Stainless Steel

- * For Split Hub Add -C to Part No.
- ** AGMA 12 Gears Add -Q12 to Part No.

For gears with a number of teeth not shown within the range listed above, substitute the required number of teeth for the digits at the end of the Part Number.

Pricing can be determined by using our online E-Commerce price list for the next higher published part number in the listing.

Gear Data			Stainless Steel Part No.	Aluminum Part No.
No. Teeth	P.D.	O.D.		
30	1.2500	1.333	P7-2-30	P4-2-30
35	1.4583	1.541	P7-2-35	P4-2-35
36	1.5000	1.583	P7-2-36	P4-2-36
40	1.6666	1.750	P7-2-40	P4-2-40
42	1.7500	1.833	P7-2-42	P4-2-42
45	1.8750	1.958	P7-2-45	P4-2-45
48	2.0000	2.083	P7-2-48	P4-2-48
50	2.0833	2.166	P7-2-50	P4-2-50
54	2.2500	2.333	P7-2-54	P4-2-54
55	2.2910	2.375	P7-2-55	P4-2-55
60	2.5000	2.583	P7-2-60	P4-2-60
65	2.7083	2.793	P7-2-65	P4-2-65
66	2.7500	2.833	P7-2-66	P4-2-66

Other Size Bores Available. Consult Factory.

Additional anti-backlash styles can be found on other pages in this section

ANTI-BACKLASH GEAR-24 PITCH — 3/16" Face Width ■ 20° Pressure Angle

Compact Design ■ Pin Hub — 1/4" Bores

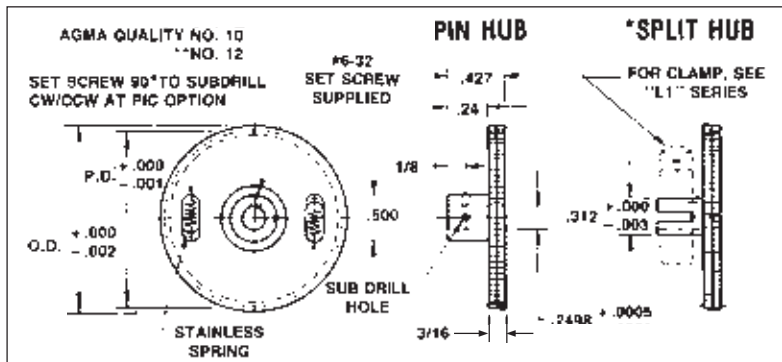

Material:

- Gears — 303 Stainless Steel
- 2024-T4 Aluminum
- (Anodized Before Cutting)
- Hubs — 303 Stainless Steel

- * For Split Hub Add -C to Part No.
- ** AGMA 12 Gears Add -Q12 to Part No.

For gears with a number of teeth not shown within the range listed above, substitute the required number of teeth for the digits at the end of the Part Number.

Pricing can be determined by using our online E-Commerce price list for the next higher published part number in the listing.

Gear Data			Stainless Steel Part No.	Aluminum Part No.
No. Teeth	P.D.	O.D.		
30	1.2500	1.333	P17-2-30	P14-2-30
35	1.4583	1.541	P17-2-35	P14-2-35
36	1.5000	1.583	P17-2-36	P14-2-36
40	1.6666	1.750	P17-2-40	P14-2-40
42	1.7500	1.833	P17-2-42	P14-2-42
45	1.8750	1.958	P17-2-45	P14-2-45
48	2.0000	2.083	P17-2-48	P14-2-48
50	2.0833	2.166	P17-2-50	P14-2-50
54	2.2500	2.333	P17-2-54	P14-2-54
55	2.2910	2.375	P17-2-55	P14-2-55
60	2.5000	2.583	P17-2-60	P14-2-60
65	2.7083	2.793	P17-2-65	P14-2-65
66	2.7500	2.833	P17-2-66	P14-2-66

Other Size Bores Available. Consult Factory.

Additional anti-backlash styles can be found on other pages in this section

ANTI-BACKLASH GEAR-24 PITCH — 3/16" Face Width ■ 20° Pressure Angle

Miniature Design ■ Pin Hub — 3/16", 1/4" Bores

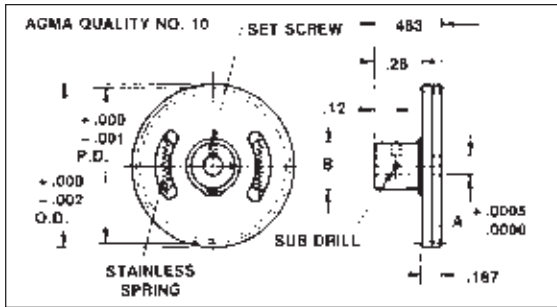

Dimen.	Bore	
	3/16	1/4
A	.1873	.2498
B	.375	.500
Set Screw	#4-40	#6-32

Gear Data			Stainless Steel Part No. Bore Size		Aluminum Part No. Bore Size	
No. Teeth	P.O.	O.D.	.1873	.2498	.1873	.2498
24	1.0000	1.083	P23-1-24	—	P24-1-24	—
25	1.0416	1.125	P23-1-25	—	P24-1-25	—
26	1.0833	1.166	P23-1-26	P25-1-26	P24-1-26	P25-1-26
28	1.1666	1.250	P23-1-28	P25-1-28	P24-1-28	P25-1-28

Additional anti-backlash styles can be found on other pages in this section

For gears with a number of teeth not shown within the range listed above, substitute the required number of teeth for the digits at the end of the Part Number.

Pricing can be determined by using our online E-Commerce price list for the next higher published part number in the listing.

Gears — 303 Stainless Steel
2024-T4 Aluminum (Anodized Before Cutting)
Hubs — 303 Stainless Steel

ANTI-BACKLASH PINION-24 & 32 PITCH 20° Pressure Angle

Pin Hub — 1/4" Face Width ■ 1/4" Bore ■ AGMA Quality No. 10

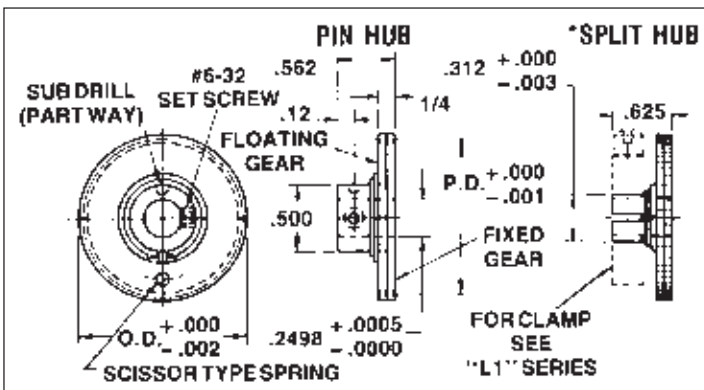

Pitch	Gear Data			Stainless Steel Part No.	Aluminum Part No.
	No. Teeth	P.D.	O.D.		
24	18	.7500	.833	P70-2-18	P40-2-18
	21	.8750	.958	P70-2-21	P40-2-21
	24	1.0000	1.083	P70-2-24	P40-2-24
32	24	.7500	.813	P70-4-24	P40-4-24
	28	.8750	.938	P70-4-28	P40-4-28
	32	1.0000	1.063	P70-4-32	P40-4-32

Other Size Bores Available. Consult Factory.

Additional anti-backlash styles can be found on other pages in this section

For gears with a number of teeth not shown within the range listed above, substitute the required number of teeth for the digits at the end of the Part Number.

Pricing can be determined by using our online E-Commerce price list for the next higher published part number in the listing.

Gears — 303 Stainless Steel
2024-T4 Aluminum (Anodized Before Cutting)
*For split hub add -C to Part Number

ANTI-BACKLASH GEAR-32 PITCH & 1/10th CIR. PITCH

20° Pressure Angle ■ Miniature Design ■ Pin Hub — 1/4" Bores, 3/16" Face Width

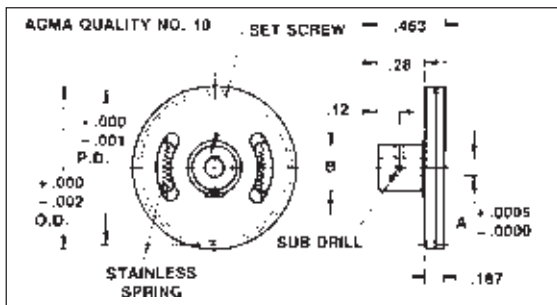

Dimen.	Bore	
	3/16	1/4
A	.1873	.2498
B	.375	.500
Set Screw	#4-40	#6-32

Pitch	Gear Data			Stainless Steel Part No. Bore Size		Aluminum Part No. Bore Size	
	No. Teeth	P.D.	O.D.	.1873	.2498	.1873	.2498
1/10	32	1.1185	1.082	P23-2-32	—	P24-2-32	—
	34	1.0822	1.146	P23-2-34	P25-2-34	P24-2-34	P26-2-34
	35	1.1141	1.178	P23-2-35	P25-2-35	P24-2-35	P26-2-35
	36	1.1459	1.210	P23-2-36	P25-2-36	P24-2-36	P26-2-36
	38	1.2095	1.271	P23-2-38	P25-2-38	P24-2-38	P26-2-38
32	40	1.2732	1.337	P23-2-40	P25-2-40	P24-2-40	P26-2-40
	32	1.0000	1.062	P23-3-32	—	P24-3-32	—
	34	1.0625	1.126	P23-3-34	P25-3-34	P24-3-34	P26-3-34
	35	1.1250	1.187	P23-3-35	P25-3-35	P24-3-35	P26-3-35
	38	1.1875	1.250	P23-3-38	P25-3-38	P24-3-38	P26-3-38

Other Size Bores Available. Consult Factory

Additional anti-backlash styles can be found on other pages in this section

For gears with a number of teeth not shown within the range listed above, substitute the required number of teeth for the digits at the end of the Part Number.
Pricing can be determined by using our online E-Commerce price list for the next higher published part number in the listing.

Gears — 303 Stainless Steel
2024-T4 Aluminum (Anodized Before Cutting)
Hubs — 303 Stainless Steel

ANTI-BACKLASH GEAR-32 PITCH — 3/16" Face Width ■ 20° Pressure Angle

Interchangeable Design ■ Pin Hub — 1/4" Bores

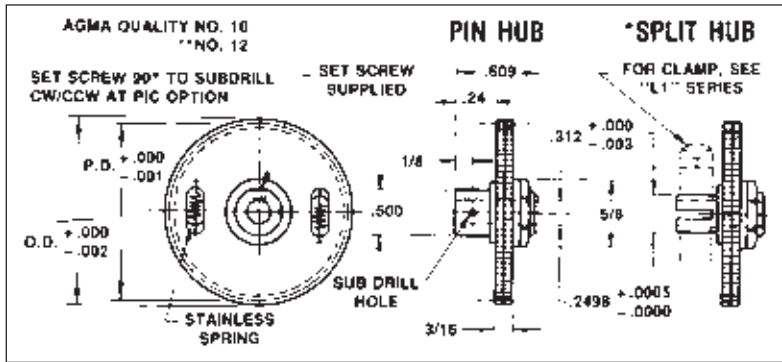

Material:

- Gears — 303 Stainless Steel
- 2024-T4 Aluminum
- (Anodized Before Cutting)
- Hubs — 303 Stainless Steel

- * For Split Hub Add -C to Part No.
- ** AGMA 12 Gears Add -D12 to Part No.

For gears with a number of teeth not shown within the range listed above, substitute the required number of teeth for the digits at the end of the Part Number.

Pricing can be determined by using our online E-Commerce price list for the next higher published part number in the listing.

Gear Data			Stainless Steel Part No.	Aluminum Part No.
No. Teeth	P.D.	O.D.		
40	1.2500	1.312	P7-4-40	P4-4-40
45	1.4060	1.468	P7-4-45	P4-4-45
48	1.5000	1.562	P7-4-48	P4-4-48
50	1.5625	1.625	P7-4-50	P4-4-50
55	1.7187	1.781	P7-4-55	P4-4-55
56	1.7500	1.812	P7-4-56	P4-4-56
60	1.8750	1.937	P7-4-60	P4-4-60
64	2.0000	2.062	P7-4-64	P4-4-64
65	2.0325	2.093	P7-4-65	P4-4-65
70	2.1875	2.250	P7-4-70	P4-4-70
72	2.2500	2.312	P7-4-72	P4-4-72
75	2.3438	2.406	P7-4-75	P4-4-75
80	2.5000	2.562	P7-4-80	P4-4-80
85	2.6563	2.718	P7-4-85	P4-4-85

Other Size Bore Available. Consult Factory.

Additional anti-backlash styles can be found on other pages in this section

ANTI-BACKLASH GEAR-32 PITCH — 3/16" Face Width ■ 20° Pressure Angle

Compact Design ■ Pin Hub — 1/4" Bores

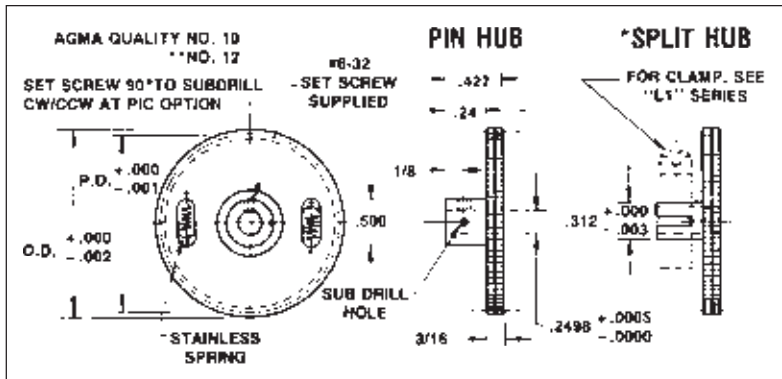

Material:

- Gears — 303 Stainless Steel
- 2024-T4 Aluminum
- (Anodized Before Cutting)
- Hubs — 303 Stainless Steel

- * For Split Hub Add -C to Part No.
- ** AGMA 12 Gears Add -D12 to Part No.

For gears with a number of teeth not shown within the range listed above, substitute the required number of teeth for the digits at the end of the Part Number.

Pricing can be determined by using our online E-Commerce price list for the next higher published part number in the listing.

Gear Data			Stainless Steel Part No.	Aluminum Part No.
No. Teeth	P.D.	O.D.		
40	1.2500	1.312	P17-4-40	P14-4-40
45	1.4060	1.468	P17-4-45	P14-4-45
48	1.5000	1.562	P17-4-48	P14-4-48
50	1.5625	1.625	P17-4-50	P14-4-50
55	1.7187	1.781	P17-4-55	P14-4-55
56	1.7500	1.812	P17-4-56	P14-4-56
60	1.8750	1.937	P17-4-60	P14-4-60
64	2.0000	2.062	P17-4-64	P14-4-64
65	2.0325	2.093	P17-4-65	P14-4-65
70	2.1875	2.250	P17-4-70	P14-4-70
72	2.2500	2.312	P17-4-72	P14-4-72
75	2.3438	2.406	P17-4-75	P14-4-75
80	2.5000	2.562	P17-4-80	P14-4-80
85	2.6563	2.718	P17-4-85	P14-4-85

Other Size Bore Available. Consult Factory.

Additional anti-backlash styles can be found on other pages in this section

ANTI-BACKLASH GEAR-48 PITCH — .104" Face Width ■ 20° Pressure Angle

Interchangeable Design ■ Pin Hub — 1/8", 3/16", 1/4" Bores

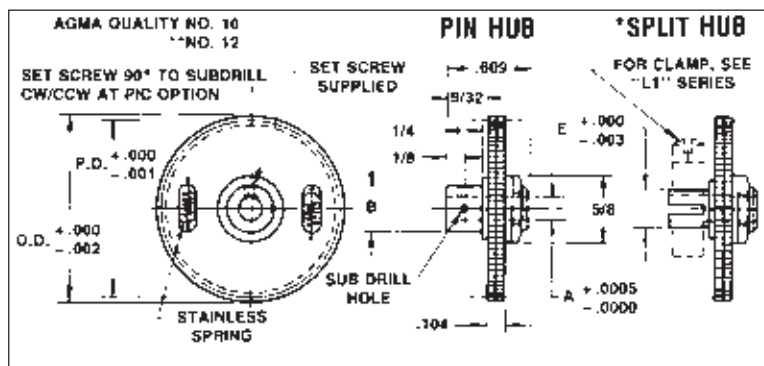

Gear Data			Stainless Steel Part No. Bore Size			Aluminum Part No. Bore Size		
No. Teeth	P.D.	O.D.	.1248	.1873	.2498	.1248	.1873	.2498
65	1.3541	1.396	P5-1-65	P6-1-65	P7-1-65	P2-1-65	P3-1-65	P4-1-65
70	1.4583	1.500	P5-1-70	P6-1-70	P7-1-70	P2-1-70	P3-1-70	P4-1-70
72	1.5000	1.542	P5-1-72	P6-1-72	P7-1-72	P2-1-72	P3-1-72	P4-1-72
75	1.5625	1.604	P5-1-75	P6-1-75	P7-1-75	P2-1-75	P3-1-75	P4-1-75
80	1.6667	1.708	P5-1-80	P6-1-80	P7-1-80	P2-1-80	P3-1-80	P4-1-80
84	1.7500	1.792	P5-1-84	P6-1-84	P7-1-84	P2-1-84	P3-1-84	P4-1-84
85	1.7708	1.812	P5-1-85	P6-1-85	P7-1-85	P2-1-85	P3-1-85	P4-1-85
90	1.8750	1.916	P5-1-90	P6-1-90	P7-1-90	P2-1-90	P3-1-90	P4-1-90
95	1.9791	2.021	P5-1-95	P6-1-95	P7-1-95	P2-1-95	P3-1-95	P4-1-95
96	2.0000	2.042	P5-1-96	P6-1-96	P7-1-96	P2-1-96	P3-1-96	P4-1-96
100	2.0833	2.125	P5-1-100	P6-1-100	P7-1-100	P2-1-100	P3-1-100	P4-1-100
105	2.1875	2.229	P5-1-105	P6-1-105	P7-1-105	P2-1-105	P3-1-105	P4-1-105
110	2.2916	2.333	P5-1-110	P6-1-110	P7-1-110	P2-1-110	P3-1-110	P4-1-110
115	2.3958	2.438	P5-1-115	P6-1-115	P7-1-115	P2-1-115	P3-1-115	P4-1-115
120	2.5000	2.541	P5-1-120	P6-1-120	P7-1-120	P2-1-120	P3-1-120	P4-1-120
125	2.6041	2.646	P5-1-125	P6-1-125	P7-1-125	P2-1-125	P3-1-125	P4-1-125
130	2.7083	2.750	P5-1-130	P6-1-130	P7-1-130	P2-1-130	P3-1-130	P4-1-130
132	2.7500	2.791	P5-1-132	P6-1-132	P7-1-132	P2-1-132	P3-1-132	P4-1-132

Other Size Bores Available. Consult Factory

Additional anti-backlash styles can be found on other pages in this section

Material:
 Gears — 303 Stainless Steel
 2024-T4 Aluminum
 (Anodized Before Cutting)
 Hubs — 303 Stainless Steel
 * For Split Hub Add -C to Part No.
 ** AGMA 12 Gears Add -Q12 to Part No.

Dimen.	Bore		
	1/8	3/16	1/4
A	.1248	.1873	.2498
B	.312	.375	.500
E	.188	.250	.312
Set Screw	#2-56	#4-40	#6-32

For gears with a number of teeth not shown within the range listed above, substitute the required number of teeth for the digits at the end of the Part Number.

Pricing can be determined by using our online E-Commerce price list for the next higher published part number in the listing.

ANTI-BACKLASH GEAR-48 PITCH — .104" Face Width ■ 20° Pressure Angle

Compact Design ■ Pin Hub — 1/8", 3/16", 1/4" Bores

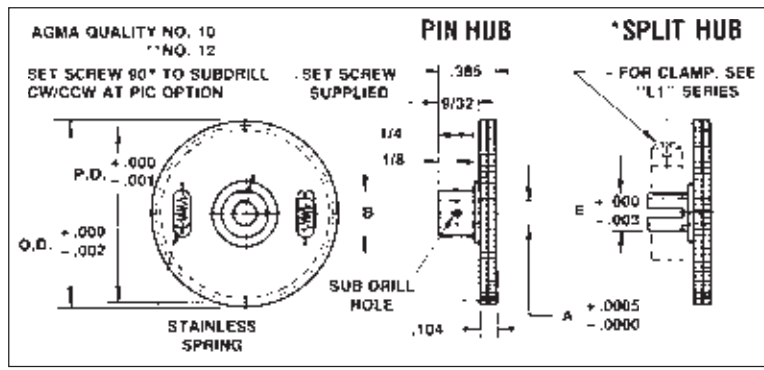

Gear Data			Stainless Steel Part No. Bore Size			Aluminum Part No. Bore Size		
No. Teeth	P.D.	O.D.	.1248	.1873	.2498	.1248	.1873	.2498
65	1.3541	1.396	P15-1-65	P16-1-65	P17-1-65	P12-1-65	P13-1-65	P14-1-65
70	1.4583	1.500	P15-1-70	P16-1-70	P17-1-70	P12-1-70	P13-1-70	P14-1-70
72	1.5000	1.542	P15-1-72	P16-1-72	P17-1-72	P12-1-72	P13-1-72	P14-1-72
75	1.5625	1.604	P15-1-75	P16-1-75	P17-1-75	P12-1-75	P13-1-75	P14-1-75
80	1.6667	1.708	P15-1-80	P16-1-80	P17-1-80	P12-1-80	P13-1-80	P14-1-80
84	1.7500	1.792	P15-1-84	P16-1-84	P17-1-84	P12-1-84	P13-1-84	P14-1-84
85	1.7708	1.812	P15-1-85	P16-1-85	P17-1-85	P12-1-85	P13-1-85	P14-1-85
90	1.8750	1.916	P15-1-90	P16-1-90	P17-1-90	P12-1-90	P13-1-90	P14-1-90
95	1.9791	2.021	P15-1-95	P16-1-95	P17-1-95	P12-1-95	P13-1-95	P14-1-95
96	2.0000	2.042	P15-1-96	P16-1-96	P17-1-96	P12-1-96	P13-1-96	P14-1-96
100	2.0833	2.125	P15-1-100	P16-1-100	P17-1-100	P12-1-100	P13-1-100	P14-1-100
105	2.1875	2.229	P15-1-105	P16-1-105	P17-1-105	P12-1-105	P13-1-105	P14-1-105
110	2.2916	2.333	P15-1-110	P16-1-110	P17-1-110	P12-1-110	P13-1-110	P14-1-110
115	2.3958	2.438	P15-1-115	P16-1-115	P17-1-115	P12-1-115	P13-1-115	P14-1-115
120	2.5000	2.541	P15-1-120	P16-1-120	P17-1-120	P12-1-120	P13-1-120	P14-1-120
125	2.6041	2.646	P15-1-125	P16-1-125	P17-1-125	P12-1-125	P13-1-125	P14-1-125
130	2.7083	2.750	P15-1-130	P16-1-130	P17-1-130	P12-1-130	P13-1-130	P14-1-130
132	2.7500	2.791	P15-1-132	P16-1-132	P17-1-132	P12-1-132	P13-1-132	P14-1-132

Other Size Bores Available. Consult Factory

Additional anti-backlash styles can be found on other pages in this section

Material:
 Gears — 303 Stainless Steel
 2024-T4 Aluminum
 (Anodized Before Cutting)
 Hubs — 303 Stainless Steel
 * For Split Hub Add -C to Part No.
 ** AGMA 12 Gears Add -Q12 to Part No.

Dimen.	Bore		
	1/8	3/16	1/4
A	.1248	.1873	.2498
B	.312	.375	.500
E	.188	.250	.312
Set Screw	#2-56	#4-40	#6-32

For gears with a number of teeth not shown within the range listed above, substitute the required number of teeth for the digits at the end of the Part Number.

Pricing can be determined by using our online E-Commerce price list for the next higher published part number in the listing.

ANTI-BACKLASH GEAR-48 PITCH — .104" Face Width ■ 20° Pressure Angle

Miniature Design ■ Pin Hub — 1/8", 3/16", 1/4" Bores

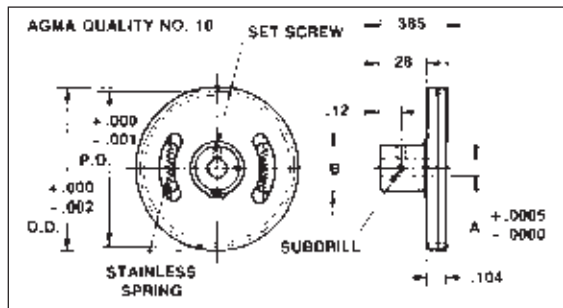

Dimen.	Bore		
	1/8	3/16	1/4
A	.248	.1873	.2496
B	.37	.375	.500
Set Screw	#2-56	#4-40	#6-32

No. Teeth	P.D.	O.D.	Stainless Steel Part No. Bore Size			Aluminum Part No. Bore Size		
			.1248	.1873	.2496	.1248	.1873	.2496
40	0.8333	0.875	P21-4-40	—	—	P22-4-48	—	—
42	0.8750	0.917	P21-4-42	—	—	P22-4-42	—	—
44	0.9167	0.958	P21-4-44	—	—	P22-4-44	—	—
46	0.9583	1.000	P21-4-46	P23-4-46	—	P22-4-46	P24-4-46	—
48	1.0000	1.041	P21-4-48	P23-4-48	—	P22-4-48	P24-4-48	—
50	1.0417	1.083	P21-4-50	P23-4-50	P25-4-50	P22-4-50	P24-4-50	P26-4-50
55	1.1458	1.187	P21-4-55	P23-4-55	P25-4-55	P22-4-55	P24-4-55	P26-4-55
56	1.1667	1.208	P21-4-56	P23-4-56	P25-4-56	P22-4-56	P24-4-56	P26-4-56
60	1.2500	1.291	P21-4-60	P23-4-60	P25-4-60	P22-4-60	P24-4-60	P26-4-60
64	1.3333	1.375	P21-4-64	P23-4-64	P25-4-64	P22-4-64	P24-4-64	P26-4-64

Additional anti-backlash styles can be found on other pages in this section.

Other Size Bores Available. Consult Factory.

Material:
Gears — 303 Stainless Steel
2024-T4 Aluminum (Anodized Before Cutting)
Hubs — 303 Stainless Steel

FOR SPECIAL ANTI BACKLASH GEARS, ORDER AS FOLLOWS:

For Unlisted Number of Teeth, Specify the Number of Teeth desired as the last figure in the part number.
EXAMPLE: For a 65 Tooth Gear, Specify Part Number P21-4-65.

ANTI-BACKLASH PINION-48, 64, 72 & 96 PITCH 20° Pressure Angle

Pin Hub — 1/8" Face Width ■ 1/8" to 1/4" Bore ■ AGMA Quality No. 10

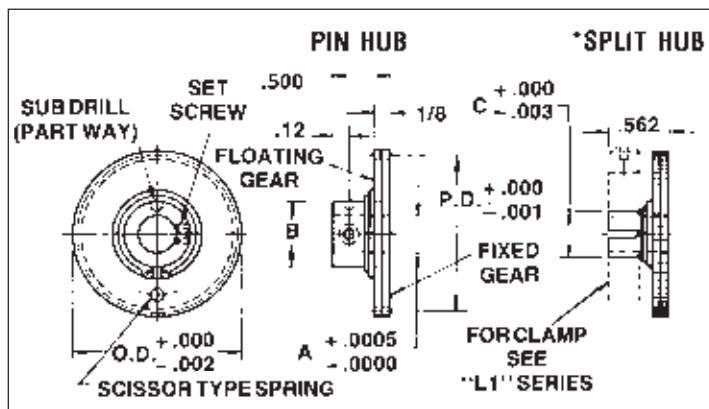

Material:
Gears — 303 Stainless Steel
2024-T4 Aluminum (Anodized Before Cutting)

*For Split hub Add -C to Part No.

Dimen.	Bore		
	1/8	3/16	1/4
A	.1248	.1873	.2496
B	.31	.37	.500
C	.188	.250	.312
Set Screw	#2-56	#4-40	#6-32

For gears with a number of teeth not shown within the range listed above, substitute the required number of teeth for the digits at the end of the Part Number.

Pricing can be determined by using our online E-Commerce price list for the next higher published part number in the listing.

Pitch	No. Teeth	P.D.	O.D.	Shaft Size	A	Stainless Steel Part No.	Aluminum Part No.
48	30	.6250	.666	3/16	.1873	P60-1-30	P30-1-30
	36	.7500	.792			P60-1-36	P30-1-36
	48	1.0000	1.042			P60-1-48	P30-1-48
64	36	.7500	.792	1/4	.2496	P70-1-36	P40-1-36
	48	1.0000	1.042			P70-1-48	P40-1-48
	40	.6250	.656	3/16	.1873	P60-3-40	P30-3-40
	48	.7500	.781			P60-3-48	P30-3-48
	64	1.0000	1.031			P60-3-64	P30-3-64
	72	48	.7500	.781	1/4	.2496	P70-3-48
64		1.0000	1.031	P70-3-64			P40-3-64
44		.6111	.639	1/8	.1248	P50-5-44	P20-5-44
56		.7777	.805			P50-5-56	P20-5-56
72		1.0000	1.028			P50-5-72	P20-5-72
96		44	.6111	.639	3/16	.1873	P60-5-44
	56	.7777	.805	P60-5-56			P30-5-56
	72	1.0000	1.028	P60-5-72			P30-5-72
	60	.6250	.646	1/8	.1248	P50-7-60	P20-7-60
	72	.7500	.771			P50-7-72	P20-7-72
	96	1.0000	1.021			P50-7-96	P20-7-96
96	60	.6250	.646	3/16	.1873	P60-7-60	P30-7-60
	72	.7500	.771			P60-7-72	P30-7-72
	96	1.0000	1.021			P60-7-96	P30-7-96

Other Size Bores Available. Consult Factory.

Additional anti-backlash styles can be found on other pages in this section.
See pages 12-39 to 12-43 for additional 64, 72 & 96 pitch anti-backlash gears.

ANTI-BACKLASH GEAR-64 PITCH — .104" Face Width ■ 20° Pressure Angle

Interchangeable Design ■ Pin Hub — 1/8", 3/16", 1/4" Bores

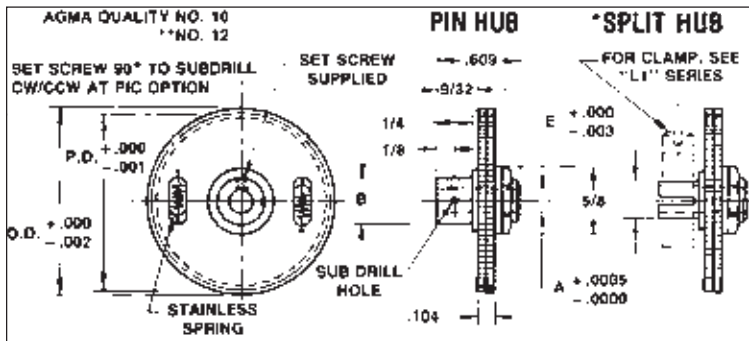

Material:

- Gears — 303 Stainless Steel
2024-T4 Aluminum
(Anodized Before Cutting)
- Hubs — 303 Stainless Steel

* For Split Hub Add -C to Part No
** AGMA 12 Gears Add -Q12 to Part No.

For gears with a number of teeth not shown within the range listed above, substitute the required number of teeth for the digits at the end of the Part Number.

Pricing can be determined by using our online E-Commerce price list for the next higher published part number in the listing.

Dimen.	Bore		
	1/8	3/16	1/4
A	1248	1873	2498
B	.312	.375	.500
E	.188	.250	.312
Set Screw	#2-56	#4-40	#6-32

Gear Data			Stainless Steel Part No. Bore Size			Aluminum Part No. Bore Size		
No. Teeth	P.D.	D.D.	.1248	.1873	.2498	.1248	.1873	.2498
85	1.3281	1.359	P5-3-85	P5-3-85	P7-3-85	P2-3-85	P3-3-85	P4-3-85
90	1.4063	1.438	P5-3-90	P5-3-90	P7-3-90	P2-3-90	P3-3-90	P4-3-90
95	1.4844	1.516	P5-3-95	P5-3-95	P7-3-95	P2-3-95	P3-3-95	P4-3-95
96	1.5000	1.531	P5-3-96	P5-3-96	P7-3-96	P2-3-96	P3-3-96	P4-3-96
100	1.5625	1.594	P5-3-100	P5-3-100	P7-3-100	P2-3-100	P3-3-100	P4-3-100
105	1.6406	1.672	P5-3-105	P5-3-105	P7-3-105	P2-3-105	P3-3-105	P4-3-105
108	1.6875	1.718	P5-3-108	P5-3-108	P7-3-108	P2-3-108	P3-3-108	P4-3-108
110	1.7187	1.750	P5-3-110	P5-3-110	P7-3-110	P2-3-110	P3-3-110	P4-3-110
115	1.7969	1.828	P5-3-115	P5-3-115	P7-3-115	P2-3-115	P3-3-115	P4-3-115
120	1.8750	1.906	P5-3-120	P5-3-120	P7-3-120	P2-3-120	P3-3-120	P4-3-120
125	1.9531	1.984	P5-3-125	P5-3-125	P7-3-125	P2-3-125	P3-3-125	P4-3-125
128	2.0000	2.031	P5-3-128	P5-3-128	P7-3-128	P2-3-128	P3-3-128	P4-3-128
130	2.0312	2.063	P5-3-130	P5-3-130	P7-3-130	P2-3-130	P3-3-130	P4-3-130
140	2.1875	2.219	P5-3-140	P5-3-140	P7-3-140	P2-3-140	P3-3-140	P4-3-140
150	2.3438	2.375	P5-3-150	P5-3-150	P7-3-150	P2-3-150	P3-3-150	P4-3-150
160	2.5000	2.531	P5-3-160	P5-3-160	P7-3-160	P2-3-160	P3-3-160	P4-3-160
170	2.6563	2.688	P5-3-170	P5-3-170	P7-3-170	P2-3-170	P3-3-170	P4-3-170
176	2.7500	2.781	P5-3-176	P5-3-176	P7-3-176	P2-3-176	P3-3-176	P4-3-176

Other Size Bores Available. Consult Factory

Additional anti-backlash styles can be found on other pages in this section

ANTI-BACKLASH GEAR-64 PITCH — .104" Face Width ■ 20° Pressure Angle

Compact Design ■ Pin Hub — 1/8", 3/16", 1/4" Bores

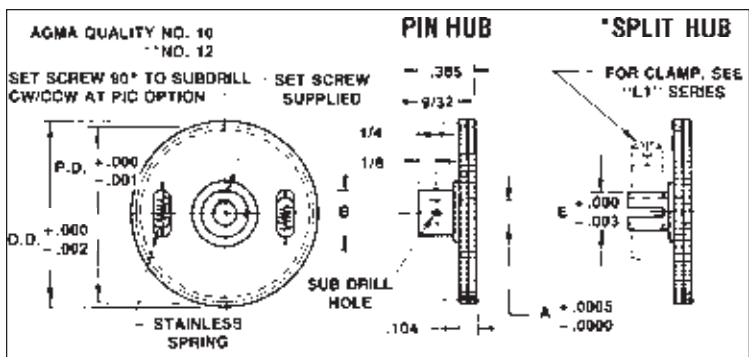

Material:

- Gears — 303 Stainless Steel
2024-T4 Aluminum
(Anodized Before Cutting)
- Hubs — 303 Stainless Steel

* For Split Hub Add -C to Part No.
** AGMA 12 Gears Add -Q12 to Part No.

For gears with a number of teeth not shown within the range listed above, substitute the required number of teeth for the digits at the end of the Part Number.

Pricing can be determined by using our online E-Commerce price list for the next higher published part number in the listing.

Dimen.	Bore		
	1/8	3/16	1/4
A	1248	1873	2498
B	.312	.375	.500
E	.188	.250	.312
Set Screw	#2-56	#4-40	#6-32

Gear Data			Stainless Steel Part No. Bore Size			Aluminum Part No. Bore Size		
No. Teeth	P.D.	D.D.	.1248	.1873	.2498	.1248	.1873	.2498
85	1.3281	1.359	P15-3-85	P15-3-85	P17-3-85	P12-3-85	P13-3-85	P14-3-85
90	1.4063	1.438	P15-3-90	P15-3-90	P17-3-90	P12-3-90	P13-3-90	P14-3-90
95	1.4844	1.516	P15-3-95	P15-3-95	P17-3-95	P12-3-95	P13-3-95	P14-3-95
96	1.5000	1.531	P15-3-96	P15-3-96	P17-3-96	P12-3-96	P13-3-96	P14-3-96
100	1.5625	1.594	P15-3-100	P15-3-100	P17-3-100	P12-3-100	P13-3-100	P14-3-100
105	1.6406	1.672	P15-3-105	P15-3-105	P17-3-105	P12-3-105	P13-3-105	P14-3-105
108	1.6875	1.718	P15-3-108	P15-3-108	P17-3-108	P12-3-108	P13-3-108	P14-3-108
110	1.7187	1.750	P15-3-110	P15-3-110	P17-3-110	P12-3-110	P13-3-110	P14-3-110
115	1.7969	1.828	P15-3-115	P15-3-115	P17-3-115	P12-3-115	P13-3-115	P14-3-115
120	1.8750	1.906	P15-3-120	P15-3-120	P17-3-120	P12-3-120	P13-3-120	P14-3-120
125	1.9531	1.984	P15-3-125	P15-3-125	P17-3-125	P12-3-125	P13-3-125	P14-3-125
128	2.0000	2.031	P15-3-128	P15-3-128	P17-3-128	P12-3-128	P13-3-128	P14-3-128
130	2.0312	2.063	P15-3-130	P15-3-130	P17-3-130	P12-3-130	P13-3-130	P14-3-130
140	2.1875	2.219	P15-3-140	P15-3-140	P17-3-140	P12-3-140	P13-3-140	P14-3-140
150	2.3438	2.375	P15-3-150	P15-3-150	P17-3-150	P12-3-150	P13-3-150	P14-3-150
160	2.5000	2.531	P15-3-160	P15-3-160	P17-3-160	P12-3-160	P13-3-160	P14-3-160
170	2.6563	2.688	P15-3-170	P15-3-170	P17-3-170	P12-3-170	P13-3-170	P14-3-170
176	2.7500	2.781	P15-3-176	P15-3-176	P17-3-176	P12-3-176	P13-3-176	P14-3-176

Other Size Bores Available. Consult Factory

Additional anti-backlash styles can be found on other pages in this section

ANTI-BACKLASH GEAR-64 PITCH — .104" Face Width ■ 20° Pressure Angle

Miniature Design ■ Pin Hub — 1/8", 3/16", 1/4" Bores

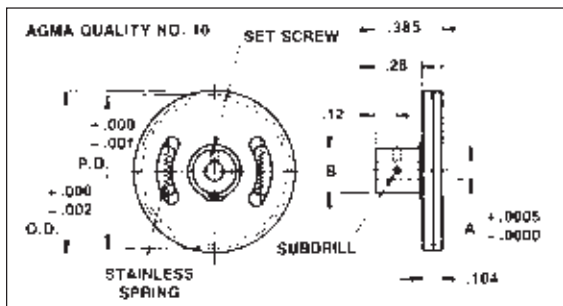

Dimen.	Bore		
	1/8	3/16	1/4
A	1248	1873	2498
B	317	375	500
Set Screw	#2-56	#4-40	#6-32

No. Teeth	P.D.	O.D.	Stainless Steel Part No. Bore Size			Aluminum Part No. Bore Size		
			.1248	.1873	.2498	.1248	.1873	.2498
59	0.8725	0.843	P21-5-52	—	—	P22-5-52	—	—
58	0.8594	0.850	P21-5-55	—	—	P22-5-55	—	—
56	0.8750	0.906	P21-5-56	—	—	P22-5-56	—	—
60	0.9375	0.968	P21-5-60	P23-5-60	P25-5-60	P22-5-60	P24-5-60	—
64	1.0000	1.031	P21-5-64	P23-5-64	P25-5-64	P22-5-64	P24-5-64	—
68	1.0625	1.093	P21-5-68	P23-5-68	P25-5-68	P22-5-68	P24-5-68	P26-5-68
70	1.0937	1.125	P21-5-70	P23-5-70	P25-5-70	P22-5-70	P24-5-70	P26-5-70
75	1.1719	1.203	P21-5-75	P23-5-75	P25-5-75	P22-5-75	P24-5-75	P26-5-75
80	1.2500	1.281	P21-5-80	P23-5-80	P25-5-80	P22-5-80	P24-5-80	P26-5-80

Other Size Bore Available Consult Factory
Additional anti-backlash styles can be found on other pages in this section

For gears with a number of teeth not shown within the range listed above, substitute the required number of teeth for the digits at the end of the Part Number.

Pricing can be determined by using our online E-Commerce price list for the next higher published part number in the listing.

ANTI-BACKLASH GEAR-72 PITCH — .104" Face Width ■ 20° Pressure Angle

Miniature Design ■ Pin Hub — 1/8", 3/16", 1/4" Bores

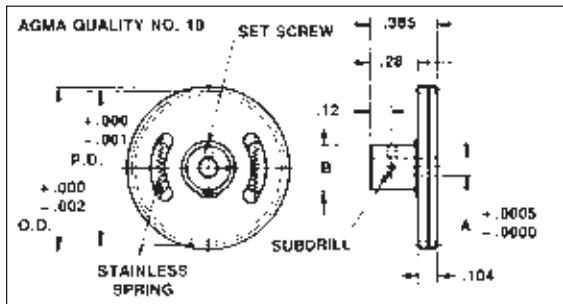

Dimen.	Bore		
	1/8	3/16	1/4
A	1248	1873	2498
B	212	375	500
Set Screw	#2-56	#4-40	#6-32

No. Teeth	P.D.	O.D.	Stainless Steel Part No. Bore Size			Aluminum Part No. Bore Size		
			.1248	.1873	.2498	.1248	.1873	.2498
58	0.8594	0.850	P21-6-58	—	—	P22-6-58	—	—
60	0.9375	0.968	P21-6-60	—	—	P22-6-60	—	—
64	1.0000	1.031	P21-6-64	—	—	P22-6-64	—	—
68	1.0625	1.093	P21-6-68	P23-6-68	—	P22-6-68	P24-6-68	—
70	1.0937	1.125	P21-6-70	P23-6-70	—	P22-6-70	P24-6-70	—
72	1.1250	1.156	P21-6-72	P23-6-72	P25-6-72	P22-6-72	P24-6-72	P26-6-72
75	1.1719	1.203	P21-6-75	P23-6-75	P25-6-75	P22-6-75	P24-6-75	P26-6-75
80	1.2500	1.281	P21-6-80	P23-6-80	P25-6-80	P22-6-80	P24-6-80	P26-6-80
84	1.3281	1.359	P21-6-84	P23-6-84	P25-6-84	P22-6-84	P24-6-84	P26-6-84
90	1.4062	1.437	P21-6-90	P23-6-90	P25-6-90	P22-6-90	P24-6-90	P26-6-90
96	1.5125	1.543	P21-6-96	P23-6-96	P25-6-96	P22-6-96	P24-6-96	P26-6-96

Other Size Bore Available Consult Factory
Additional anti-backlash styles can be found on other pages in this section

For gears with a number of teeth not shown within the range listed above, substitute the required number of teeth for the digits at the end of the Part Number.

Pricing can be determined by using our online E-Commerce price list for the next higher published part number in the listing.

Interchangeable Design ■ Pin Hub — 1/8", 3/16", 1/4" Bores — 72 Pitch

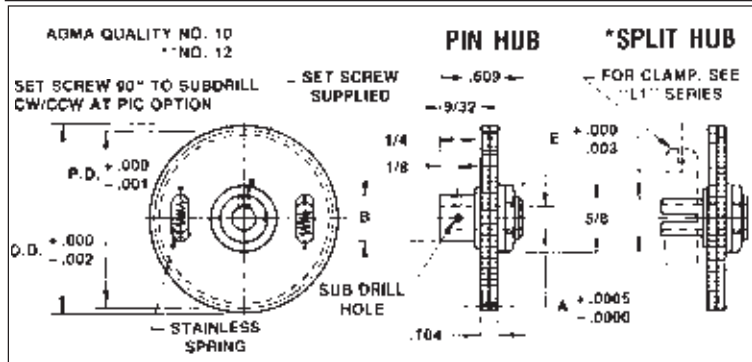

Dimen.	Bore		
	1/8	3/16	1/4
A	1248	1873	2498
B	312	375	500
E	58	290	312
Set Screw	#2-56	#4-40	#6-32

No. Teeth	P.D.	O.D.	Stainless Steel Part No. Bore Size			Aluminum Part No. Bore Size		
			.1248	.1873	.2498	.1248	.1873	.2498
100	1.3858	1.417	P5-5-100	P6-5-100	P7-5-100	P2-5-100	P3-5-100	P4-5-100
105	1.4553	1.486	P5-5-105	P6-5-105	P7-5-105	P2-5-105	P3-5-105	P4-5-105
108	1.5000	1.528	P5-5-108	P6-5-108	P7-5-108	P2-5-108	P3-5-108	P4-5-108
110	1.5277	1.556	P5-5-110	P6-5-110	P7-5-110	P2-5-110	P3-5-110	P4-5-110
115	1.5972	1.625	P5-5-115	P6-5-115	P7-5-115	P2-5-115	P3-5-115	P4-5-115
120	1.6656	1.695	P5-5-120	P6-5-120	P7-5-120	P2-5-120	P3-5-120	P4-5-120
125	1.7350	1.764	P5-5-125	P6-5-125	P7-5-125	P2-5-125	P3-5-125	P4-5-125
130	1.8055	1.833	P5-5-130	P6-5-130	P7-5-130	P2-5-130	P3-5-130	P4-5-130
140	1.9441	1.972	P5-5-140	P6-5-140	P7-5-140	P2-5-140	P3-5-140	P4-5-140
144	2.0000	2.028	P5-5-144	P6-5-144	P7-5-144	P2-5-144	P3-5-144	P4-5-144
150	2.0892	2.111	P5-5-150	P6-5-150	P7-5-150	P2-5-150	P3-5-150	P4-5-150
160	2.2222	2.244	P5-5-160	P6-5-160	P7-5-160	P2-5-160	P3-5-160	P4-5-160
170	2.3611	2.383	P5-5-170	P6-5-170	P7-5-170	P2-5-170	P3-5-170	P4-5-170
180	2.5000	2.528	P5-5-180	P6-5-180	P7-5-180	P2-5-180	P3-5-180	P4-5-180
190	2.6388	2.667	P5-5-190	P6-5-190	P7-5-190	P2-5-190	P3-5-190	P4-5-190
200	2.7778	2.806	P5-5-200	P6-5-200	P7-5-200	P2-5-200	P3-5-200	P4-5-200

Other Size Bore Available Consult Factory
Additional anti-backlash styles can be found on other pages in this section

For gears with a number of teeth not shown within the range listed above, substitute the required number of teeth for the digits at the end of the Part Number.

Pricing can be determined by using our online E-Commerce price list for the next higher published part number in the listing.

Material:
Gears — 303 Stainless Steel, 2024-T4 Aluminum (Anodized Before Cutting)
Hubs — 303 Stainless Steel

* For Split Hub Add -C to Part No.
** AGMA 12 Gears Add -Q12 to Part No.

ANTI-BACKLASH GEAR-72 PITCH — .104" Face Width ■ 20° Pressure Angle

Compact Design ■ Pin Hub — 1/8", 3/16", 1/4" Bores

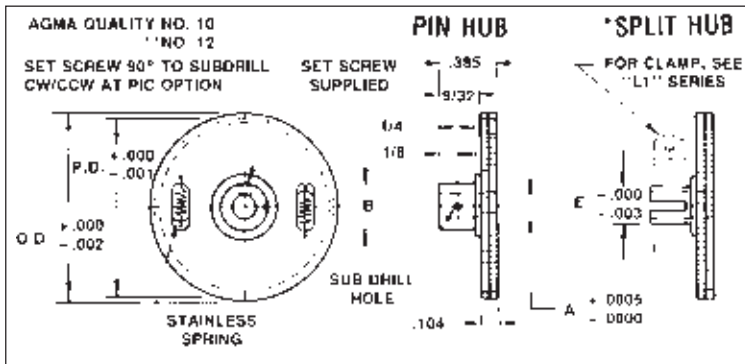

Gear Data	Stainless Steel Part No. Bore Size			Aluminum Part No. Bore Size					
	No. Teeth	P.D.	O.D.	.1248	.1873	.2498	.1248	.1873	.2498
100	1.3888	1.417		P15-5-100	P16-5-100	P17-5-100	P12-5-100	P13-5-100	P14-5-100
105	1.4951	1.480		P15-5-105	P16-5-105	P17-5-105	P12-5-105	P13-5-105	P14-5-105
108	1.5000	1.508		P15-5-108	P16-5-108	P17-5-108	P12-5-108	P13-5-108	P14-5-108
110	1.5277	1.558		P15-5-110	P16-5-110	P17-5-110	P12-5-110	P13-5-110	P14-5-110
115	1.5817	1.525		P15-5-115	P16-5-115	P17-5-115	P12-5-115	P13-5-115	P14-5-115
120	1.6656	1.995		P15-5-120	P16-5-120	P17-5-120	P12-5-120	P13-5-120	P14-5-120
125	1.7380	1.764		P15-5-125	P16-5-125	P17-5-125	P12-5-125	P13-5-125	P14-5-125
130	1.8055	1.851		P15-5-130	P16-5-130	P17-5-130	P12-5-130	P13-5-130	P14-5-130
140	1.9344	1.972		P15-5-140	P16-5-140	P17-5-140	P12-5-140	P13-5-140	P14-5-140
144	2.0000	2.028		P15-5-144	P16-5-144	P17-5-144	P12-5-144	P13-5-144	P14-5-144
150	2.0831	2.111		P15-5-150	P16-5-150	P17-5-150	P12-5-150	P13-5-150	P14-5-150
160	2.2222	2.250		P15-5-160	P16-5-160	P17-5-160	P12-5-160	P13-5-160	P14-5-160
170	2.3611	2.389		P15-5-170	P16-5-170	P17-5-170	P12-5-170	P13-5-170	P14-5-170
180	2.5000	2.528		P15-5-180	P16-5-180	P17-5-180	P12-5-180	P13-5-180	P14-5-180
190	2.6389	2.667		P15-5-190	P16-5-190	P17-5-190	P12-5-190	P13-5-190	P14-5-190
200	2.7778	2.806		P15-5-200	P16-5-200	P17-5-200	P12-5-200	P13-5-200	P14-5-200

Other Size Bores Available: Contact Factory

Additional anti-backlash styles can be found on other pages in this section

Gears — 303 Stainless Steel
2024-T4 Aluminum
(Anodized Before Cutting)
Hubs — 303 Stainless Steel

Dimen.	Bore		
	1/8	3/16	1/4
A	.1248	.1873	.2498
B	.312	.375	.500
E	.188	.250	.312
Set Screw	#2-56	#4-40	#6-32

* For Split Hub Add -C to Part No.
** AGMA 12 Gears Add -O12 to Part No

For gears with a number of teeth not shown within the range listed above, substitute the required number of teeth for the digits at the end of the Part Number.

Pricing can be determined by using our online E-Commerce price list for the next higher published part number in the listing.

ANTI-BACKLASH GEAR-80 PITCH — .104" Face Width ■ 20° Pressure Angle

Compact Design ■ Pin Hub — 1/8", 3/16", 1/4" Bores

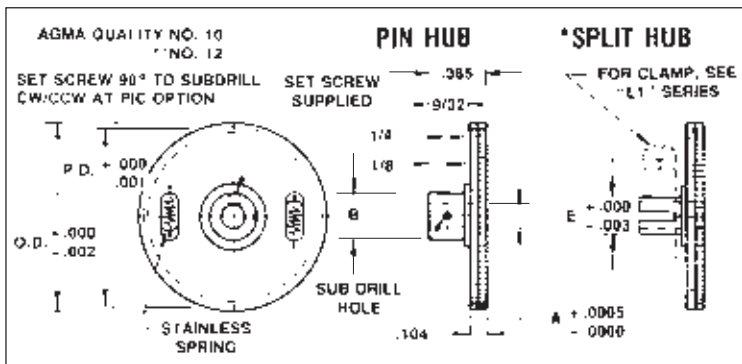

Gear Data	Stainless Steel Part No. Bore Size			Aluminum Part No. Bore Size					
	No. Teeth	P.D.	O.D.	.1248	.1873	.2498	.1248	.1873	.2498
100	1.2500	1.275		P15-6-100	P16-6-100	P17-6-100	P12-6-100	P13-6-100	P14-6-100
105	1.3125	1.337		P15-6-105	P16-6-105	P17-6-105	P12-6-105	P13-6-105	P14-6-105
110	1.3750	1.400		P15-6-110	P16-6-110	P17-6-110	P12-6-110	P13-6-110	P14-6-110
115	1.4375	1.462		P15-6-115	P16-6-115	P17-6-115	P12-6-115	P13-6-115	P14-6-115
120	1.5000	1.525		P15-6-120	P16-6-120	P17-6-120	P12-6-120	P13-6-120	P14-6-120
125	1.5625	1.587		P15-6-125	P16-6-125	P17-6-125	P12-6-125	P13-6-125	P14-6-125
130	1.6250	1.650		P15-6-130	P16-6-130	P17-6-130	P12-6-130	P13-6-130	P14-6-130
135	1.6875	1.712		P15-6-135	P16-6-135	P17-6-135	P12-6-135	P13-6-135	P14-6-135
140	1.7500	1.775		P15-6-140	P16-6-140	P17-6-140	P12-6-140	P13-6-140	P14-6-140
145	1.8125	1.837		P15-6-145	P16-6-145	P17-6-145	P12-6-145	P13-6-145	P14-6-145
150	1.8750	1.900		P15-6-150	P16-6-150	P17-6-150	P12-6-150	P13-6-150	P14-6-150
160	2.0000	2.025		P15-6-160	P16-6-160	P17-6-160	P12-6-160	P13-6-160	P14-6-160
170	2.1250	2.150		P15-6-170	P16-6-170	P17-6-170	P12-6-170	P13-6-170	P14-6-170
180	2.2500	2.275		P15-6-180	P16-6-180	P17-6-180	P12-6-180	P13-6-180	P14-6-180
190	2.3750	2.400		P15-6-190	P16-6-190	P17-6-190	P12-6-190	P13-6-190	P14-6-190
200	2.5000	2.525		P15-6-200	P16-6-200	P17-6-200	P12-6-200	P13-6-200	P14-6-200
220	2.7500	2.775		P15-6-220	P16-6-220	P17-6-220	P12-6-220	P13-6-220	P14-6-220

Other Size Bores Available: Contact Factory

Material:
Gears — 303 Stainless Steel
2024-T4 Aluminum (Black Anodize)
Hubs — 303 Stainless Steel

Dimen.	Bore		
	1/8	3/16	1/4
A	.1248	.1873	.2498
B	.312	.375	.500
E	.188	.250	.312
Set Screw	#2-56	#4-40	#6-32

* For Split Hub Add -C to Part No.
** AGMA 12 Gears add -O12 to Part No.

For gears with a number of teeth not shown within the range listed above, substitute the required number of teeth for the digits at the end of the Part Number.

Pricing can be determined by using our online E-Commerce price list for the next higher published part number in the listing.

ANTI-BACKLASH GEAR-96 PITCH — .104" Face Width ■ 20° Pressure Angle

Miniature Design ■ Pin Hub — 1/8", 3/16", 1/4" Bores

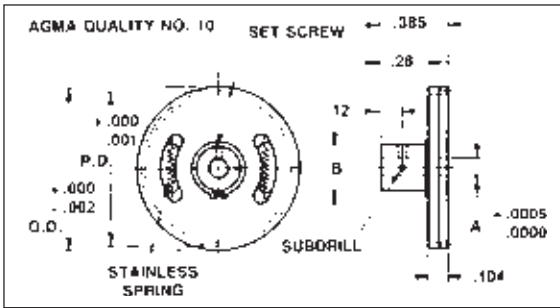

Dimen.	Bore		
	1/8	3/16	1/4
A	1749	1873	2498
B	312	375	500
Set Screw	#2-56	#4-40	#6-32

Additional anti-backlash styles can be found on other pages in this section

Gear Data	Stainless Steel Part No. Bore Size			Aluminum Part No. Bore Size					
	No. Teeth	P.O.	O.D.	.1248	.1873	.2498	.1248	.1873	.2498
26	2.917	0.812		P21-8-76			P22-8-76		
50	2.833	0.854		P21-8-80			P22-8-80		
54	2.820	0.896		P21-8-84			P22-8-84		
60	2.812	0.958		P21-8-90	P23-8-90		P22-8-90	P24-8-90	
96	1.8000	1.200		P21-8-96	P23-8-96	P25-8-96	P22-8-96	P24-8-96	P26-8-96
100	1.827	1.262		P21-8-100	P23-8-100	P25-8-100	P22-8-100	P24-8-100	P26-8-100
104	1.750	1.145		P21-8-106	P23-8-106	P25-8-106	P22-8-106	P24-8-106	P26-8-106
112	1.746	1.187		P21-8-112	P23-8-112	P25-8-112	P22-8-112	P24-8-112	P26-8-112
120	1.720	1.270		P21-8-120	P23-8-120	P25-8-120	P22-8-120	P24-8-120	P26-8-120
125	1.801	1.322		P21-8-125	P23-8-125	P25-8-125	P22-8-125	P24-8-125	P26-8-125

Material:

- Gears — 303 Stainless Steel
2024-T4 Aluminum (Anodized Before Cutting)
- Hubs — 303 Stainless Steel

For gears with a number of teeth not shown within the range listed above, substitute the required number of teeth for the digits at the end of the Part Number. Pricing can be determined by using our online E-Commerce price list for the next higher published part number in the listing.

ANTI-BACKLASH GEAR-96 PITCH — .104" Face Width ■ 20° Pressure Angle

Compact Design ■ Pin Hub — 1/8", 3/16", 1/4" Bores

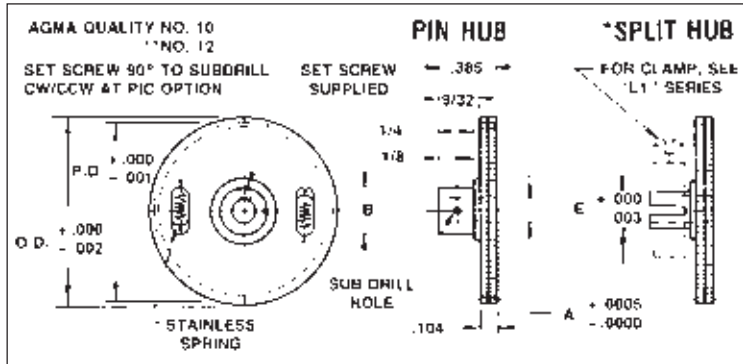

Dimen.	Bore		
	1/8	3/16	1/4
A	1248	1873	2498
B	312	375	500
E	188	250	312
Set Screw	#2-56	#4-40	#6-32

Gear Data	Stainless Steel Part No. Bore Size			Aluminum Part No. Bore Size					
	No. Teeth	P.O.	O.D.	.1248	.1873	.2498	.1248	.1873	.2498
130	1.354*	1.570		P15-7-130	P16-7-130	P17-7-130	P12-7-130	P13-7-130	P14-7-130
135	1.405*	1.427		P15-7-135	P16-7-135	P17-7-135	P12-7-135	P13-7-135	P14-7-135
140	1.458*	1.479		P15-7-140	P16-7-140	P17-7-140	P12-7-140	P13-7-140	P14-7-140
144	1.500	1.52*		P15-7-144	P16-7-144	P17-7-144	P12-7-144	P13-7-144	P14-7-144
145	1.534	1.53*		P15-7-145	P16-7-145	P17-7-145	P12-7-145	P13-7-145	P14-7-145
150	1.5624	1.563*		P15-7-150	P16-7-150	P17-7-150	P12-7-150	P13-7-150	P14-7-150
160	1.6666	1.567		P15-7-160	P16-7-160	P17-7-160	P12-7-160	P13-7-160	P14-7-160
170	1.770*	1.730		P15-7-170	P16-7-170	P17-7-170	P12-7-170	P13-7-170	P14-7-170
180	1.8750	1.896		P15-7-180	P16-7-180	P17-7-180	P12-7-180	P13-7-180	P14-7-180
190	1.9791	2.000		P15-7-190	P16-7-190	P17-7-190	P12-7-190	P13-7-190	P14-7-190
192	2.0000	2.02*		P15-7-192	P16-7-192	P17-7-192	P12-7-192	P13-7-192	P14-7-192
200	2.0935	2.104		P15-7-200	P16-7-200	P17-7-200	P12-7-200	P13-7-200	P14-7-200
210	2.1874	2.208		P15-7-210	P16-7-210	P17-7-210	P12-7-210	P13-7-210	P14-7-210
220	2.2816	2.312		P15-7-220	P16-7-220	P17-7-220	P12-7-220	P13-7-220	P14-7-220
230	2.3758	2.410		P15-7-230	P16-7-230	P17-7-230	P12-7-230	P13-7-230	P14-7-230
240	2.5000	2.521		P15-7-240	P16-7-240	P17-7-240	P12-7-240	P13-7-240	P14-7-240
250	2.5040	2.625		P15-7-250	P16-7-250	P17-7-250	P12-7-250	P13-7-250	P14-7-250
260	2.6087	2.729		P15-7-260	P16-7-260	P17-7-260	P12-7-260	P13-7-260	P14-7-260
264	2.7500	2.771		P15-7-264	P16-7-264	P17-7-264	P12-7-264	P13-7-264	P14-7-264

Other Size Bores Available - Contact Factory

Additional anti-backlash styles can be found on other pages in this section

Material:

- Gears — 303 Stainless Steel
2024-T4 Aluminum (Black Anodize)
- Hubs — 303 Stainless Steel

* For Split Hub Add -C to Part No.
** AGMA 12 Gears add — Q12 to Part No.

For gears with a number of teeth not shown within the range listed above, substitute the required number of teeth for the digits at the end of the Part Number. Pricing can be determined by using our online E-Commerce price list for the next higher published part number in the listing.

HELICAL GEAR-48 NORMAL PITCH $\frac{3}{16}$ " Face Width ■ 20° Pressure Angle

45° Helical Angle ■ Pin Hub — $\frac{3}{16}$ ", $\frac{1}{4}$ " Bores ■ AGMA Quality No. 10

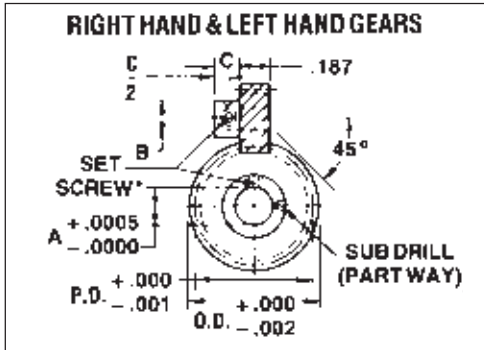

Material: 303 Stainless Steel
2024-T4 Aluminum (Anodized Before Cutting)

* Set Screw 90° To Subdrill
CW/CCW At PIC Option

Note:

For right angle drives use same handed gears.

Thrust bearings may be required.
See technical section 13-4

Dimen.	Bore	
	$\frac{3}{16}$	$\frac{1}{4}$
A	.1573	.2498
B	.375	.500
C	.219	.250
Set Screw	#4-40	#6-32

Gear Data				$\frac{3}{16}$ " Bore		$\frac{1}{4}$ " Bore	
No. Teeth	P.D.	O.D.	Material	Part No. Right Hand	Part No. Left Hand	Part No. Right Hand	Part No. Left Hand
20	5892	.631	Stainless Aluminum	AC3-20 AC4-20	AD3-20 AD4-20	AC1-20 AC2-20	AD1-20 AD2-20
25	7365	.778	Stainless Aluminum	AC3-25 AC4-25	AD3-25 AD4-25	AC1-25 AC2-25	AD1-25 AD2-25
30	8838	.925	Stainless Aluminum	AC3-30 AC4-30	AD3-30 AD4-30	AC1-30 AC2-30	AD1-30 AD2-30
35	1 0311	1.072	Stainless Aluminum	AC3-35 AC4-35	AD3-35 AD4-35	AC1-35 AC2-35	AD1-35 AD2-35
40	1 1784	1.220	Stainless Aluminum	AC3-40 AC4-40	AD3-40 AD4-40	AC1-40 AC2-40	AD1-40 AD2-40
45	1 3258	1.367	Stainless Aluminum	AC3-45 AC4-45	AD3-45 AD4-45	AC1-45 AC2-45	AD1-45 AD2-45
50	1 4730	1.514	Stainless Aluminum	AC3-50 AC4-50	AD3-50 AD4-50	AC1-50 AC2-50	AD1-50 AD2-50
60	1 7676	1 809	Stainless Aluminum	AC3-60 AC4-60	AD3-60 AD4-60	AC1-60 AC2-60	AD1-60 AD2-60
70	2 0622	2.194	Stainless Aluminum	AC3-70 AC4-70	AD3-70 AD4-70	AC1-70 AC2-70	AD1-70 AD2-70

Other Size Bores Available. Consult Factory.

FOR SPECIAL HELICAL GEARS, ORDER AS FOLLOWS:

For Unlisted Number of Teeth, Specify the Number of Teeth desired as the last figure in the part number.
EXAMPLE: For a 55 Tooth Gear, Specify Part Number: AD1-55.

HELICAL GEAR-64 NORMAL PITCH $\frac{1}{8}$ ", $\frac{3}{16}$ " Face Width ■ 20° Pressure Angle

45° Helical Angle ■ Pin Hub — $\frac{1}{8}$ ", $\frac{3}{16}$ " Bores ■ AGMA Quality No. 10

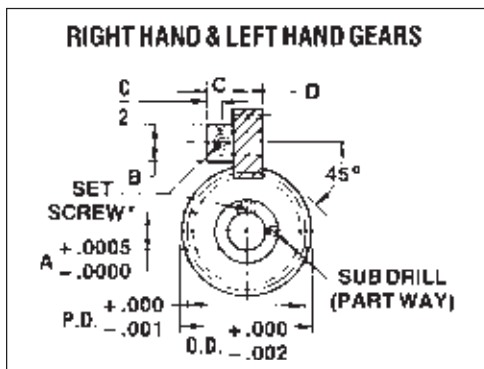

Material: 303 Stainless Steel
2024-T4 Aluminum (Anodized Before Cutting)

* Set Screw 90° To Subdrill
CW/CCW At PIC Option

Dimen.	Bore	
	$\frac{1}{8}$	$\frac{3}{16}$
A	.1248	.1873
B	.312	.375
C	.187	.219
D	.125	.187
Set Screw	#2-56	#4-40

Gear Data				$\frac{1}{8}$ " Bore		$\frac{3}{16}$ " Bore	
No. Teeth	+ .000 - .001 P.D.	+ .000 - .002 O.D.	Material	Part No. Right Hand	Part No. Left Hand	Part No. Right Hand	Part No. Left Hand
20	.449	.473	Stainless Aluminum	AC7-20 AC8-20	AD7-20 AD8-20	AC5-20 AC6-20	AD5-20 AD6-20
25	.5524	.583	Stainless Aluminum	AC7-25 AC8-25	AD7-25 AD8-25	AC5-25 AC6-25	AD5-25 AD6-25
30	.6629	.694	Stainless Aluminum	AC7-30 AC8-30	AD7-30 AD8-30	AC5-30 AC6-30	AD5-30 AD6-30
35	.7733	.804	Stainless Aluminum	AC7-35 AC8-35	AD7-35 AD8-35	AC5-35 AC6-35	AD5-35 AD6-35
40	.8838	.915	Stainless Aluminum	AC7-40 AC8-40	AD7-40 AD8-40	AC5-40 AC6-40	AD5-40 AD6-40
45	.9943	1 025	Stainless Aluminum	AC7-45 AC8-45	AD7-45 AD8-45	AC5-45 AC6-45	AD5-45 AD6-45
50	1 1048	1 136	Stainless Aluminum	AC7-50 AC8-50	AD7-50 AD8-50	AC5-50 AC6-50	AD5-50 AD6-50
60	1 3257	1 357	Stainless Aluminum	AC7-60 AC8-60	AD7-60 AD8-60	AC5-60 AC6-60	AD5-60 AD6-60
70	1 5466	1 577	Stainless Aluminum	AC7-70 AC8-70	AD7-70 AD8-70	AC5-70 AC6-70	AD5-70 AD6-70

Other Size Bores Available. Consult Factory.

FOR SPECIAL HELICAL GEARS, ORDER AS FOLLOWS:

For Unlisted Number of Teeth, Specify the Number of Teeth desired as the last figure in the part number.
EXAMPLE: For a 35 Tooth Gear, Specify Part Number: AD6-55

WORM WHEEL - 48 PITCH — 14½°, 20°, 25° Pressure Angle

Right Hand ■ Single, Double & Four Thread ■ Pin Hub, Split Hub — 1/8", 3/16" & 1/4" Bores ■ AGMA Quality No. 10

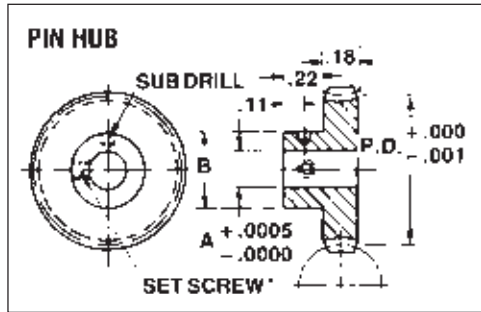

Material: Bronze ASTM B21 Alloy 464

$$\text{Ratio} = \frac{\text{No. Teeth}}{\text{No. Threads}}$$

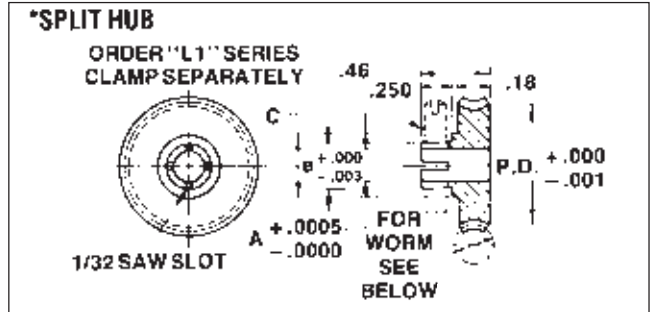

* Set Screw 90° To Subdrill CW/CCW At PIC Option

PIN HUB					Single Thread (14½° P.A.)	Double Thread (20° P.A.)	Four Thread (25° P.A.)			
Gear Data										
No. Teeth	Pitch Dia.	A	B	Set Screw	Part No.	Part No.	Part No.			
30	6250	1248 (1/8)	3/2	#2.56	Q7-14	Q9-14	Q11-14			
40	8333				Q7-15	Q9-15	Q11-15			
50	10417				Q7-1	Q9-1	Q11-1			
60	12500				Q7-2	Q9-2	Q11-2			
70	14583				Q7-16	Q9-16	Q11-16			
80	16667				Q7-3	Q9-3	Q11-3			
90	18750				Q7-4	Q9-4	Q11-4			
100	20833				Q7-17	Q9-17	Q11-17			
120	25000				Q7-18	Q9-18	Q11-18			
30	6250				1873 (3/16)	3/2	#4.40	Q7-19	Q9-19	Q11-19
40	8333							Q7-20	Q9-20	Q11-20
50	10417							Q7-5	Q9-5	Q11-5
60	12500	Q7-6	Q9-6	Q11-6						
70	14583	Q7-21	Q9-21	Q11-21						
80	16667	Q7-7	Q9-7	Q11-7						
90	18750	Q7-8	Q9-8	Q11-8						
100	20833	Q7-22	Q9-22	Q11-22						
120	25000	Q7-23	Q9-23	Q11-23						
30	6250	2498 (1/4)	.500	#6.32				Q7-24	Q9-24	Q11-24
40	8333							Q7-25	Q9-25	Q11-25
50	10417							Q7-9	Q9-9	Q11-9
60	12500				Q7-10	Q9-10	Q11-10			
70	14583				Q7-26	Q9-26	Q11-26			
80	16667				Q7-11	Q9-11	Q11-11			
90	18750				Q7-12	Q9-12	Q11-12			
100	20833				Q7-27	Q9-27	Q11-27			
120	25000				Q7-28	Q9-28	Q11-28			
160	37500				Q7-13	Q9-13	Q11-13			

SPLIT HUB							Single Thread (14½° P.A.)	Double Thread (20° P.A.)	Four Thread (25° P.A.)
Gear Data									
No. Teeth	Pitch Dia.	A	B	C	Clamp No. (Ref.)	Part No.	Part No.	Part No.	
50	1042	1248 (1/8)	188	1/4	L1.4	Q7-1-C	Q9-1-C	Q11-1-C	
60	1250					Q7-2-C	Q9-2-C	Q11-2-C	
80	1667					Q7-3-C	Q9-3-C	Q11-3-C	
90	1875					Q7-4-C	Q9-4-C	Q11-4-C	
50	1042	1873 (3/16)	250	3/16	L1.5	Q7-5-C	Q9-5-C	Q11-5-C	
60	1250					Q7-6-C	Q9-6-C	Q11-6-C	
80	1667					Q7-7-C	Q9-7-C	Q11-7-C	
90	1875					Q7-8-C	Q9-8-C	Q11-8-C	
50	1042	2498 (1/4)	3/2	3/8	L1.6	Q7-9-C	Q9-9-C	Q11-9-C	
60	1250					Q7-10-C	Q9-10-C	Q11-10-C	
80	1667					Q7-11-C	Q9-11-C	Q11-11-C	
90	1875					Q7-12-C	Q9-12-C	Q11-12-C	
160	3750					Q7-13-C	Q9-13-C	Q11-13-C	

Other Numbers of Teeth and Material Available on Request. Consult Factory.

Single Thread (Q7 Series) Meshes With Q8 Worm Only
 Double Thread (Q9 Series) Meshes With Q10 Worm Only
 Four Thread (Q11 Series) Meshes With Q12 Worm Only

Other Numbers of Teeth and Material Available on Request. Consult Factory.

WORM - 48 PITCH — 14½°, 20°, 25° Pressure Angle

Right Hand ■ Single, Double & Four Thread ■ Pin Hub — 1/8" & 3/16" Bores

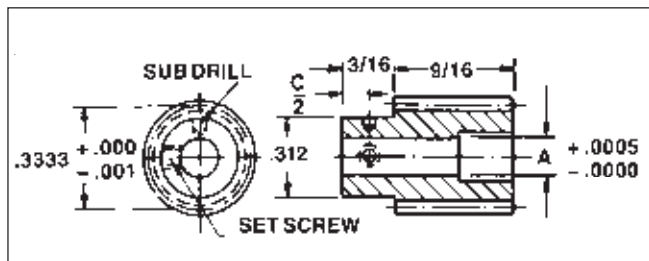

Shah Size	A	Set Screw	Use With Single Thread (14½° P.A.)	Use With Double Thread (20° P.A.)	Use With Four Thread (25° P.A.)
			Part No.	Part No.	Part No.
1/8	1248	#2.56	Q8-1	Q10-1	Q12-1
3/16	1873	#4.40	Q8-2	Q10-2	Q12-2

Material: 303 Stainless Steel

Part No.	Lead	Lead Angle
Q8	.0654	3° 35'
Q10	.1308	7° 10'
Q12	.2618	14° 20'

ANTI-BACKLASH WORM WHEEL - 48 PITCH

Single, Double & Four Thread ■ Pin Hub — 1/8", 3/16" & 1/4" Bores ■ AGMA Quality No. 10

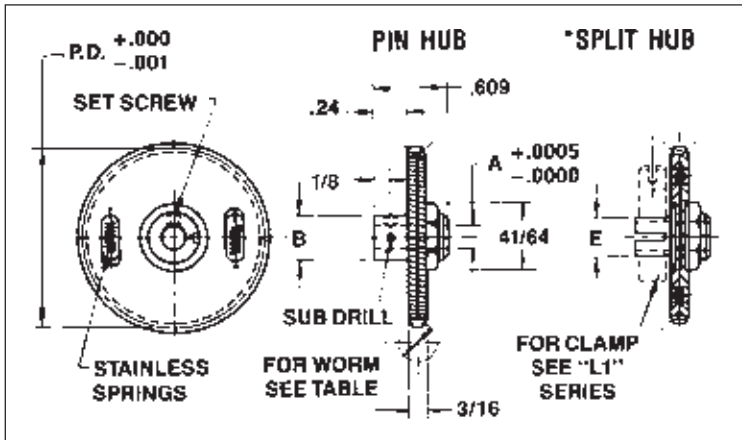

Material:

Gears — Bronze QQB 639 Alloy 464
Hubs — 303 Stainless Steel

*For Split Hub Add -C to Part No

Dimen.	Bore		
	1/8	3/16	1/4
A	1245	1673	2498
B	31	37	500
E	125	250	317
Set Screw	#2-56	#4-40	#6-32

Matched Pairs
Right Hand

Gear Data				Part Number Bore Size		
No. Teeth	Pitch Dia.	Thread	Use With Worm #	.1248	.1673	.2498
70	1.4583	Single	08	Q14-1	Q14-7	Q14-13
72	1.5000			Q14-19	Q14-31	Q14-43
80	1.6667			Q14-20	Q14-32	Q14-44
90	1.8750			Q14-21	Q14-33	Q14-45
96	2.0000			Q14-22	Q14-34	Q14-46
100	2.0633			Q14-2	Q14-8	Q14-14
70	1.4583	Double	D10	Q14-9	Q14-9	Q14-15
72	1.5000			Q14-23	Q14-35	Q14-47
80	1.6667			Q14-24	Q14-36	Q14-48
90	1.8750			Q14-25	Q14-37	Q14-49
96	2.0000			Q14-26	Q14-38	Q14-50
100	2.0633			Q14-4	Q14-10	Q14-16
70	1.4583	Four	D12	Q14-5	Q14-11	Q14-17
72	1.5000			Q14-27	Q14-39	Q14-51
80	1.6667			Q14-28	Q14-40	Q14-52
90	1.8750			Q14-29	Q14-41	Q14-53
96	2.0000			Q14-30	Q14-42	Q14-54
100	2.0633			Q14-6	Q14-12	Q14-18

For the exact Number of Teeth and Bore Sizes, Consult Factory

Thread	Pressure Angle
Single	14.5°
Double	20°
Four	25°

ANTI-BACKLASH WORM WHEEL - MINIATURE - 48 PITCH

Single, Double & Four Thread ■ Pin Hub — 1/8", 3/16" & 1/4" Bores

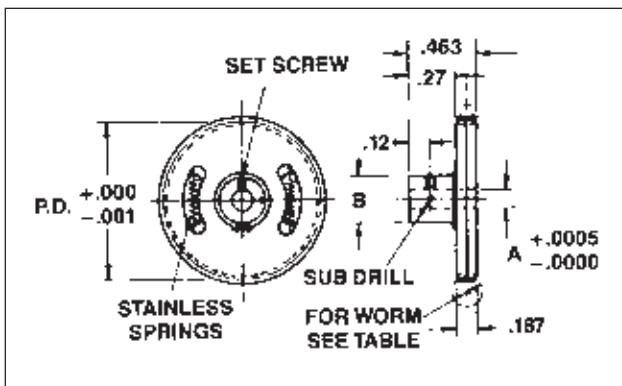

Material:

Gears — Bronze QQB 639 Alloy 464
Hubs — 303 Stainless Steel

Dimen.	Bore		
	1/8	3/16	1/4
A	1248	1673	2498
B	31.2	.375	500
Set Screw	#2-56	#4-40	#6-32

Gear Data				Part Number Bore Size		
No. Teeth	Pitch Dia.	Thread	Use With Worm #	.1248	.1673	.2498
40	0.8333	Single	08	Q15-1	—	—
50	1.0417			Q15-3	Q17-2	Q19-1
60	1.2500			Q15-5	Q17-4	Q19-3
40	0.8333	Double	D10	Q15-6	—	—
50	1.0417			Q15-8	Q17-6	Q19-4
60	1.2500			Q15-10	Q17-8	Q19-6
40	0.8333	Four	D12	Q15-11	—	—
50	1.0417			Q15-13	Q17-10	Q19-7
60	1.2500			Q15-15	Q17-12	Q19-9

For the exact Number of Teeth and Bore Sizes, Consult Factory

Thread	Pressure Angle
Single	14.5°
Double	20°
Four	25°

WORM WHEEL - 64 PITCH — 14½° Pressure Angle

Right Hand ■ Single, Double & Four Thread ■ Pin Hub, Split Hub — 1/8", 3/16" & 1/4" Bores ■ AGMA Quality No. 10

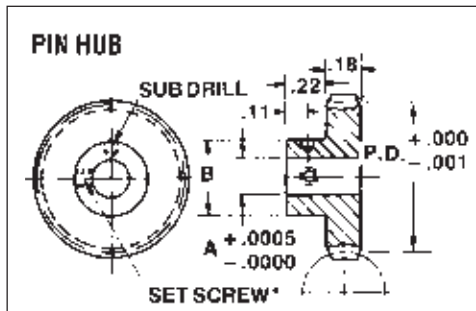

Material: Bronze QQ-B-637
Alloy 464

$$\text{Ratio} = \frac{\text{No. Teeth}}{\text{No. Threads}}$$

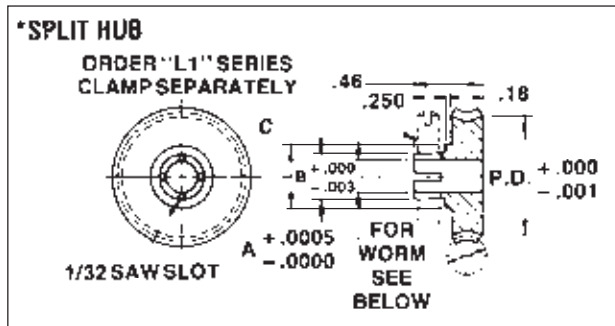

* Set Screw 90° To Subdrill
CW/CCW At PIC Option

PIN HUB

Gear Data					Single Thread	Double Thread	Four Thread
No. Teeth	Pitch Dia.	A	B	Set Screw	Cat. No.	Cat. No.	Cat. No.
40	6250				01-14	03-14	05-14
50	7813				01-15	03-15	05-15
60	9375				01-1	03-1	05-1
70	10938	1248	312	#2-56	01-16	03-16	05-16
80	12500	(.78)			01-2	03-2	05-2
90	14063				01-17	03-17	05-17
100	15625				01-3	03-3	05-3
110	17187				01-18	03-18	05-18
120	18750				01-4	03-4	05-4
40	6250				01-19	03-19	05-19
50	7813				01-20	03-20	05-20
60	9375				01-5	03-5	05-5
70	10938	1873	375	#4-40	01-21	03-21	05-21
80	12500	(.78)			01-6	03-6	05-6
90	14063				01-22	03-22	05-22
100	15625				01-7	03-7	05-7
110	17187				01-23	03-23	05-23
120	18750				01-8	03-8	05-8
40	6250				01-24	03-24	05-24
50	7813				01-25	03-25	05-25
60	9375				01-9	03-9	05-9
70	10938	2498	500	#6-32	01-26	03-26	05-26
80	12500	(.78)			01-10	03-10	05-10
90	14063				01-27	03-27	05-27
100	15625				01-11	03-11	05-11
110	17187				01-28	03-28	05-28
120	18750				01-12	03-12	05-12
360	56250				01-13	03-13	05-13

Other Numbers of Teeth and Material Available on Request. Consult Factory

SPLIT HUB

Gear Data						Single Thread	Double Thread	Four Thread
No. Teeth	Pitch Dia.	A	B	C	Clamp No. (Ref.)	Part No.	Part No.	Part No.
60	937					01-1-C	03-1-C	05-1-C
80	1250	1248	180	.14	L: 4	01-2-C	03-2-C	05-2-C
100	1562	(.78)				01-3-C	03-3-C	05-3-C
120	1875					01-4-C	03-4-C	05-4-C
60	937					01-5-C	03-5-C	05-5-C
80	1250	1873	250	5/16	L: 5	01-6-C	03-6-C	05-6-C
100	1562	(.78)				01-7-C	03-7-C	05-7-C
120	1875					01-8-C	03-8-C	05-8-C
60	937					01-9-C	03-9-C	05-9-C
80	1250	2498	312	3/8	L: 6	01-10-C	03-10-C	05-10-C
100	1562	(.78)				01-11-C	03-11-C	05-11-C
120	1875					01-12-C	03-12-C	05-12-C
360	5625					01-13-C	03-13-C	05-13-C

Other Numbers of Teeth and Material Available on Request. Consult Factory

Single Thread (Q1 Series) Meshes With Q2 Worm Only
Double Thread (Q3 Series) Meshes With Q4 Worm Only
Four Thread (Q5 Series) Meshes With Q6 Worm Only

WORM - 64 PITCH — 14½° Pressure Angle

Right Hand ■ Single, Double & Four Thread ■ Pin Hub — 1/8", 3/16" & 1/4" Bores ■ AGMA Quality No. 10

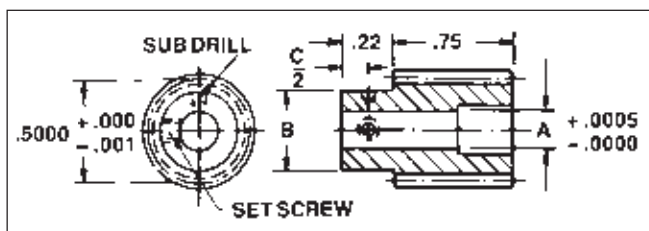

Material: 303 Stainless Steel

Screw Size	A	B	Set Screw	Use With	Use With	Use With
				Single Thread	Double Thread	Four Thread
				Part No.	Part No.	Part No.
1/8	1248	312	#2-56	Q2-1	Q4-1	Q6-1
3/16	1873	375	#4-40	Q2-2	Q4-2	Q6-2
1/4	2498	437	#6-32	Q2-3	Q4-3	Q6-3

Part No.	Lead	Lead Angle
Q2	.04908	1° 41'
Q4	.09817	3° 35'
Q6	.14725	7° 11'

ANTI-BACKLASH WORM WHEEL - 64 PITCH

14 1/2° Pressure Angle ■ Single, Double & Four Thread ■ Pin Hub — 1/8", 3/16" & 1/4" Bores

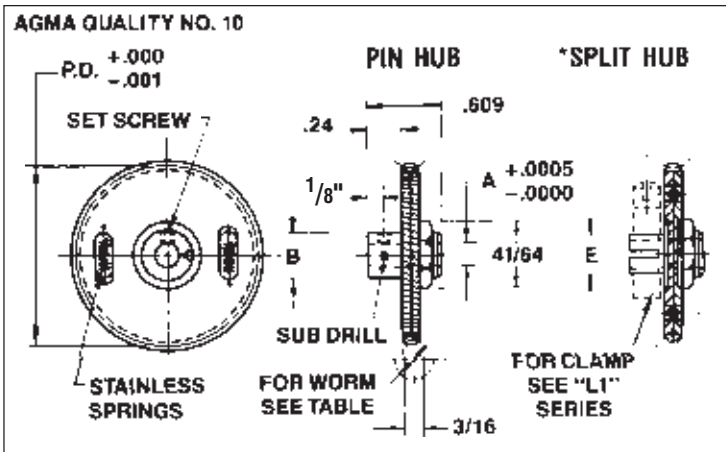

Gear Data				Part Number		
No. Teeth	Pitch Dia.	Thread	Use With Worm #	.1248	.1873	.2498
9E	1.5000	Single	G2	Q13-19	Q13-31	Q13-43
10C	1.5625			Q13-1	Q13-7	Q13-13
11C	1.7187			Q13-20	Q13-32	Q13-44
12C	1.8750			Q13-21	Q13-33	Q13-45
13C	2.0312			Q13-22	Q13-34	Q13-46
14C	2.1875			Q13-2	Q13-8	Q13-14
9E	1.5000	Double	D4	Q13-23	Q13-35	Q13-47
10C	1.5625			Q13-3	Q13-9	Q13-15
11C	1.7187			Q13-24	Q13-36	Q13-48
12C	1.8750			Q13-25	Q13-37	Q13-49
13C	2.0312			Q13-26	Q13-38	Q13-50
14C	2.1875			Q13-4	Q13-10	Q13-16
9E	1.5000	Four	G6	Q13-27	Q13-39	Q13-51
10C	1.5625			Q13-5	Q13-11	Q13-17
11C	1.7187			Q13-28	Q13-40	Q13-52
12C	1.8750			Q13-29	Q13-41	Q13-53
13C	2.0312			Q13-30	Q13-42	Q13-54
14C	2.1875			Q13-6	Q13-12	Q13-18

For Unlisted Number of Teeth and Other Bore Sizes, Consult Factory

Material:

Gears — Bronze QQB 639 Alloy 464
Hubs — 303 Stainless Steel

*For Split Hub Add -C to Part No

Dimen.	Bore		
	1/8	3/16	1/4
A	1248	1873	2498
B	31	37	500
E	188	250	312
Set Screw	#2-56	#4-40	#6-32

Matched Pairs
Right Hand

ANTI-BACKLASH WORM WHEEL - MINIATURE - 64 PITCH

14 1/2° Pressure Angle ■ Single, Double & Four Thread ■ Pin Hub — 1/8", 3/16" & 1/4" Bores

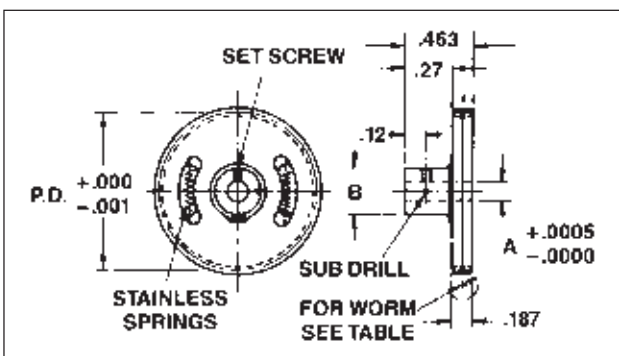

Gear Data				Part Number		
No. Teeth	Pitch Dia.	Thread	Use With Worm #	.1248	.1873	.2498
60	0.9375	Single	G2	Q16-2	Q16-1	—
70	1.0937			Q16-4	Q16-3	Q20-2
80	1.2500			Q16-5	Q16-4	Q20-3
90	1.4062			Q16-6	Q16-5	Q20-4
60	0.9375	Double	D4	Q16-8	Q16-6	—
70	1.0937			Q16-10	Q16-8	Q20-6
80	1.2500			Q16-11	Q16-9	Q20-7
90	1.4062			Q16-12	Q16-10	Q20-8
60	0.9375	Four	G6	Q16-14	Q16-11	—
70	1.0937			Q16-16	Q16-13	Q20-10
80	1.2500			Q16-17	Q16-14	Q20-11
90	1.4062			Q16-18	Q16-15	Q20-12

For Unlisted Number of Teeth and Other Bore Sizes, Consult Factory

Material:

Gears — Bronze QQB 639 Alloy 464
Hubs — 303 Stainless Steel

Dimen.	Bore		
	1/8	3/16	1/4
A	1248	1873	2498
B	312	375	500
Set Screw	#2-56	#4-40	#6-32

MITER & BEVEL GEARS- 48 PITCH — 20° Pressure Angle

Pin Hub — 1/4" Bore ■ Matched Pairs ■ AGMA Quality No. 10 and 12

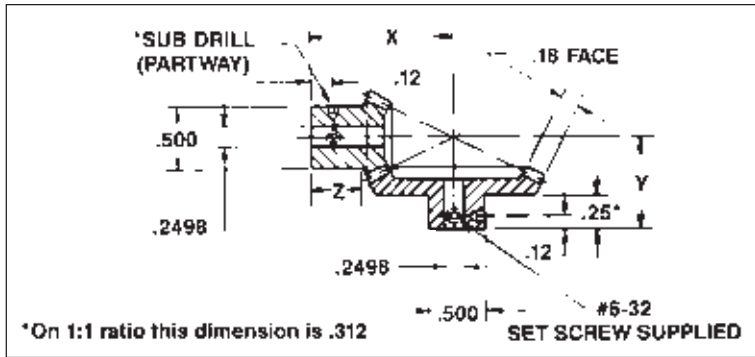

Material: 303 Stainless Steel — S
2024-T4 Aluminum (Anodized Before Cutting) — A

*Sub Drill 90° To Set Screw Location Optional

Miter Gear Sets (1:1 Ratio)
Consists of 2 Gears of Identical Dimensions

Tolerances	Q10	Q12
Bore	+ .0005 - .0000	+ .0003 - .0000
Pitch Diameter	+ .000 - .001	+ .0000 - .0007
Total Composite Tolerance	FOR AGMA QUALITY STANDARDS	
Tooth to Tooth Tolerance	SEE PAGE 12-2	

Gear Data							Part No. Per Set
Ratio	No. Teeth	Material	P.D.	X	Y	Z	
1:1	30:30	S/A S/S A/A	625: 625	687	687	312	N3-1 N3-1-S N3-1-A
1:1 1/2	30:45	S/A S/S A/A	625: 637	812	687	302	N3-5 N3-5-S N3-5-A
1:2	30:60	S/A S/S A/A	625:1: 650	937	687	281	N3-2 N3-2-S N3-2-A
1:3	30:90	S/A S/S A/A	625:1: 875	1:250	687	292	N3-3 N3-3-S N3-3-A
1:4	30:120	S/A S/S A/A	625:1: 500	1:501	687	265	N3-4 N3-4-S N3-4-A

Split Hubs, Other Ratios and Bore Available on Request, Consult Factory

To order AGMA 12 Gears, add — Q12 to Part No.

When ordering individual parts, specify set no. along with individual part.
EXAMPLE: N3-1 (Pinion Only) or N3-1 (Gear Only)

MITER & BEVEL GEARS- 64 PITCH — 20° Pressure Angle

Pin Hub — 3/16" Bore ■ Matched Pairs ■ AGMA Quality No. 10 and 12

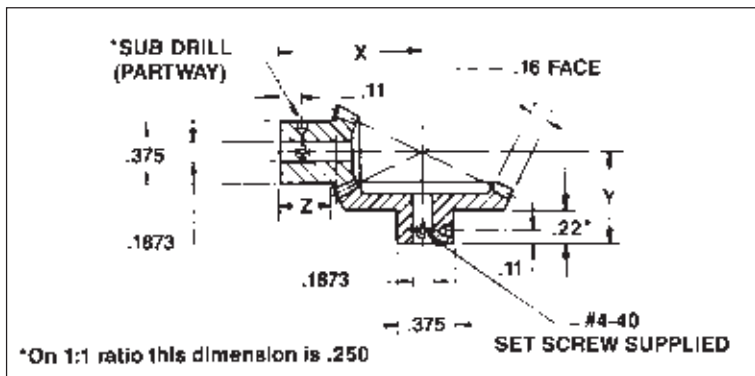

Material: 303 Stainless Steel — S
2024-T4 Aluminum (Anodized Before Cutting) — A

*Sub Drill 90° To Set Screw Location Optional

Miter Gear Sets (1:1 Ratio)
Consists of 2 Gears of Identical Dimensions

Tolerances	Q10	Q12
Bore	+ .0005 - .0000	+ .0003 - .0000
Pitch Diameter	+ .000 - .001	+ .0000 - .0007
Total Composite Tolerance	FOR AGMA QUALITY STANDARDS	
Tooth to Tooth Tolerance	SEE PAGE 12-2	

Gear Data							Part No. Per Set
Ratio	No. Teeth	Material	P.D.	X	Y	Z	
1:1	32:32	S/A S/S A/A	500: 500	567	567	250	N2-1 N2-1-S N2-1-A
1:1 1/2	32:48	S/A S/S A/A	500: 750	658	567	248	N2-8 N2-8-S N2-8-A
1:2	32:64	S/A S/S A/A	500:1: 000	750	567	219	N2-2 N2-2-S N2-2-A
1:3	32:96	S/A S/S A/A	500:1: 500	1:000	567	228	N2-3 N2-3-S N2-3-A
1:4	32:128	S/A S/S A/A	500:2: 000	1:250	567	204	N2-4 N2-4-S N2-4-A

Split Hubs, Other Ratios and Bore Available on Request, Consult Factory

To order AGMA 12 Gears, add — Q12 to Part No.

When ordering individual parts, specify set no. along with individual part.
EXAMPLE: N2-1 (Pinion Only) or N2-1 (Gear Only)

MITER & BEVEL GEARS- 72 PITCH — 20° Pressure Angle

Pin Hub — 1/8" Bore ■ Matched Pairs ■ AGMA Quality No. 10 and 12

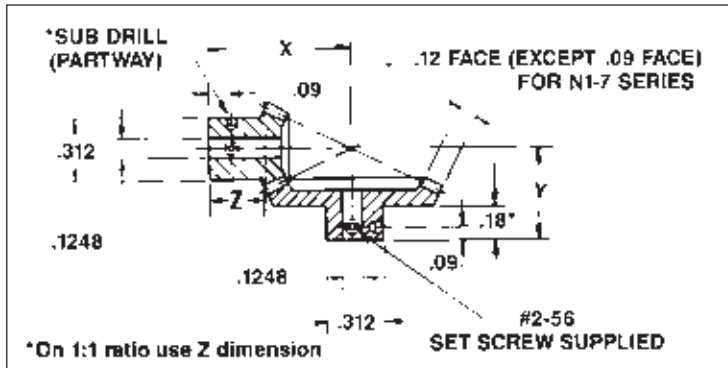

Material: 303 Stainless Steel — S
2024-T4 Aluminum (Anodized Before Cutting) — A

*Sub Drill 90° To Set Screw Location Optional

Miter Gear Sets (1:1 Ratio)
Consists of 2 Gears of Identical Dimensions

Tolerances	Q10	Q12
Bore	+ .0005 - .0000	+ .0003 - .0000
Pinch Diameter	+ .000 - .001	+ .0000 - .0007
Total Composite Tolerance	FOR AGMA QUALITY STANDARDS	
Tooth to Tooth Tolerance	SEE PAGE 12-2	

Gear Data							Part No. Per Set
Ratio	No. Teeth	Material	P.O.	X	Y	Z	
1:1	24-24	S/A	333-333	437	437	263	N1-7
		S/S					N1-7-S
		A/A					N1-7-A
1:1	36-36	S/A	500-500	531	531	187	N1-1
		S/S					N1-1-S
		A/A					N1-1-A
1 1/2:1	36-54	S/A	500-750	543	531	215	N1-B
		S/S					N1-B-S
		A/A					N1-B-A
1:2	36-72	S/A	500-1000	753	531	203	N1-2
		S/S					N1-2-S
		A/A					N1-2-A
1:3	36-108	S/A	500-1500	1000	531	218	N1-3
		S/S					N1-3-S
		A/A					N1-3-A
1:4	36-144	S/A	500-2000	1250	531	228	N1-4
		S/S					N1-4-S
		A/A					N1-4-A

SP: P.O. Other Ratios and Bore Sizes Available. Contact Factory.

To order AGMA 12 Gears, add - Q12 to Part No.

When ordering individual parts, specify set no. along with individual part
EXAMPLE: N1-7 (Pinion Only) or N1-7 (Gear Only).

ANTI-BACKLASH MITER GEARS-48, 64 & 72 PITCH — 20° Pressure Angle

Pin Hub — 1/8", 3/16" & 1/4" Bores ■ Matched Pairs ■ AGMA Quality No. 10 ■ 1:1 Ratio Only

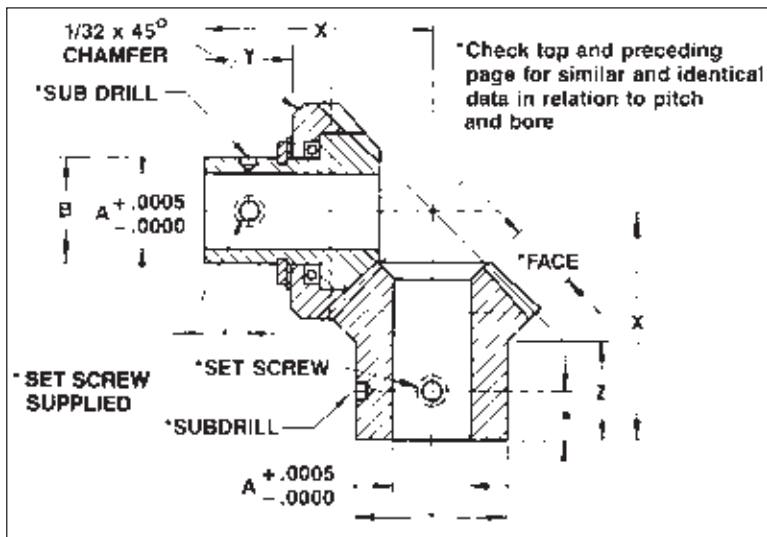

Material: Anti-Backlash Gear — 303 Stainless Steel
Mating Gear — 303 Stainless Steel or 2024-T4
Aluminum (Anodized Before Cutting) — A

Gear Data								Part No. Per Set	
Pitch	No. Teeth	Material	P.D.	A	B	K	Y		Z
72	36-36	S/A	500-500	1248	112	131	165	187	N1-1-AB
		S/S	500-500	1248	112	131	165	187	N1-1-AB-S
		A/A							
64	32-32	S/A	500-500	1873	176#	169	212	250	N2-1-AB
		S/S	500-500	1873	176#	169	212	250	N2-1-AB-S
		A/A							
48	32-30	S/A	625-625	2496	315	187	257	312	N3-1-AB
		S/S	625-625	2496	315	187	257	312	N3-1-AB-S
		A/A							

Other Ratios and Bore Sizes Available. Contact Factory.

PRECISION SPIRAL GEARS

Pin Hub ■ Left Hand ■ 1/8", 3/16" & 1/4" Shafts & Bores

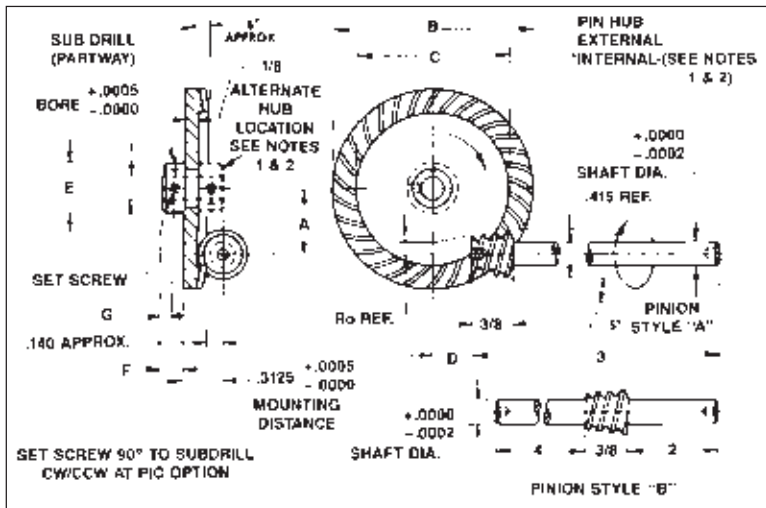

Material: Gears - Bronze ASTM B21, Alloy 464
Pinions and Hubs — 303 Stainless Steel

Bores			Gear — Runs With All Pinions					
.1248 Dia. .1673 Dia.		.2496 Dia.	Ratio	A	B	C	D	Ro
Part No.	Part No.	Part No.						
EK1-1	EK2-1	EK3-1	36:1	.330	1.375	.868	.281	.150"
EK1-2	EK2-2	EK3-2	40:1	.368	1.453	.948	.297	.167"
EK1-5	EK2-5	EK3-5	70:1	.650	2.038	1.553	.411	.388"
EK1-6	EK2-6	EK3-6	80:1	.744	2.233	1.755	.450	.453"
EK1-7	EK2-7	EK3-7	90:1	.837	2.427	1.957	.489	.520"
EK1-8	EK2-8	EK3-8	100:1	.931	2.622	2.158	.525	.587"
EK1-9	EK2-9	EK3-9	120:1	1.119	3.012	2.562	.602	.720"
EK1-11	EK2-11	EK3-11	180:1	1.683	4.182	3.772	.832	1.019"
EK1-12	EK2-12	EK3-12	200:1	1.871	4.571	4.175	.908	1.093"

Split Hubs Available On Request. Consult Factory.

Notes: 1. For Internal sub-drill, X to Part Number.
2. Check Clearance between Pinion and Hub when using Gears with Hubs of 36:1 and 40:1.

Dimension	Hub Data		
	EK1	EK2	EK3
E	.716	.716	1.7
F	.77	.77	.25
G	..	.11	.12
Set Screw	ø2.56	ø4.40	ø6.17

Pinions		
Part No.	Style	Shaft Dia.
EJ1-A		.1247
EJ2-A	"A"	.1872
EJ3-A		.2497
EJ1-B		.1247
EJ2-B	"B"	.1872
EJ3-B		.2497

PRECISION SPIRAL GEARS

Hubless ■ Left Hand ■ 3/8", 11/16" Bores

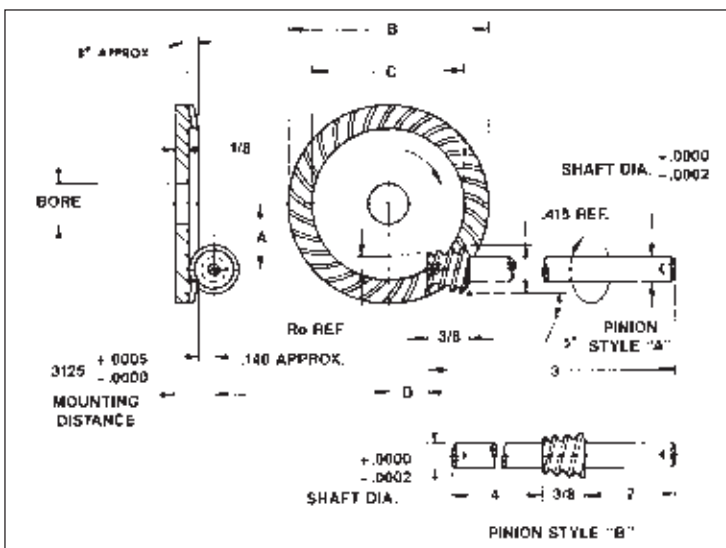

Material: Gears — Bronze ASTM B21, Alloy 464
Pinions and Hubs — 303 Stainless Steel

Bores			Gear — Runs With All Pinions					
.3750 +.0000 -.0002		.6875 +.0003 -.0003	Ratio	A	B	C	D	Ro
Part No.	Part No.	Part No.						
EK13-1	EK14-1		36:1	.330	1.375	.868	.281	.150"
EK13-2	EK14-2		40:1	.368	1.453	.948	.297	.167"
EK13-5	EK14-5		70:1	.650	2.038	1.553	.411	.388"
EK13-6	EK14-6		80:1	.744	2.233	1.755	.450	.453"
EK13-7	EK14-7		90:1	.837	2.427	1.957	.488	.520"
EK13-8	EK14-8		100:1	.931	2.622	2.158	.526	.587"
EK13-9	EK14-9		120:1	1.119	3.012	2.562	.602	.720"
EK13-10	EK14-10		150:1	1.401	3.597	3.167	.717	.920"
EK13-11	EK14-11		180:1	1.683	4.182	3.772	.832	1.019"
EK13-12	EK14-12		200:1	1.871	4.571	4.175	.908	1.093"

Split Hubs Available On Request. Consult Factory.

Pinions		
Part No.	Style	Shaft Dia.
EJ1-A		.1247
EJ2-A	"A"	.1872
EJ3-A		.2497
EJ1-B		.1247
EJ2-B	"B"	.1872
EJ3-B		.2497

GEAR BLANKS — NO TEETH

Pin Hub — 1/8" Face Width ■ 1/4" Bore

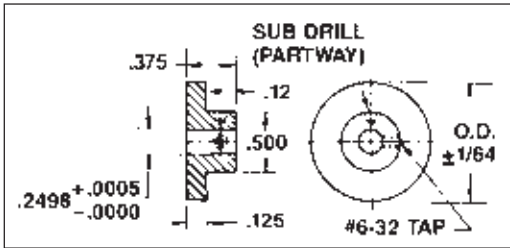

Material: 303 Stainless Steel
2024-T4 Aluminum (Anodized)

Outside Dia.	Stainless Steel Part No.	Aluminum Part No.
1	BP1-8	BP2-8
1½	BP1-12	BP2-12
2	BP1-16	BP2-16
2½	BP1-20	BP2-20
4	BP1-32	BP2-32

GEAR BLANKS — NO TEETH

Pin Hub — 3/16" Face Width ■ 1/4" Bore

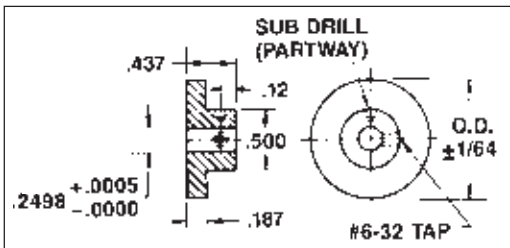

Material: 303 Stainless Steel
2024-T4 Aluminum (Anodized)

Outside Dia.	Stainless Steel Part No.	Aluminum Part No.
1	BQ1-8	BQ2-8
1½	BQ1-12	BQ2-12
2	BQ1-16	BQ2-16
2½	BQ1-20	BQ2-20
4	BQ1-32	BQ2-32

GEAR BLANKS — NO TEETH

Hubless — 1/8" Face Width ■ 3/8" Bore

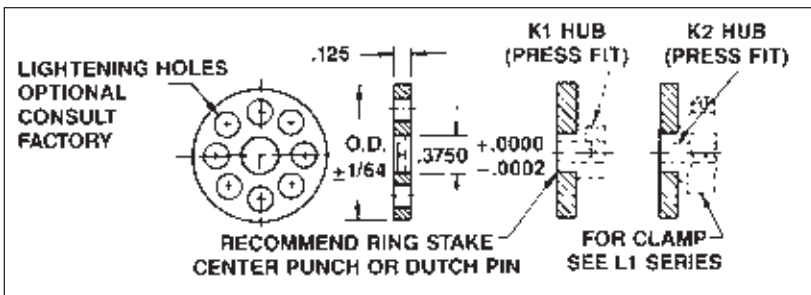

Material: 303 Stainless Steel
2024-T4 Aluminum (Anodized)

Outside Dia.	Stainless Steel Part No.	Aluminum Part No.
1	BU1-8	BU2-8
1½	BU1-12	BU2-12
2	BU1-16	BU2-16
2½	BU1-20	BU2-20
3	BU1-24	BU2-24
3½	BU1-28	BU2-28
4	BU1-32	BU2-32

Other Materials, Bores, Face Widths, Diameters On Request.
Clamp Type Blanks Available, Consult Factory.
Modifications Quoted On Request

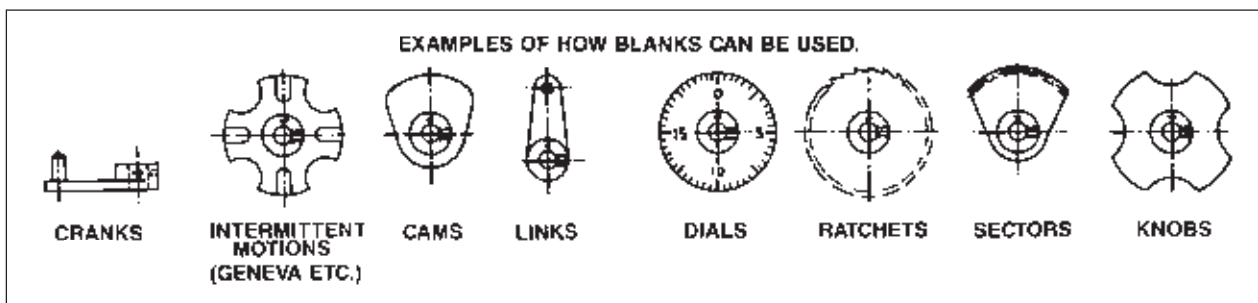

SPUR GEARS — 0.25 Module ■ 1.58, 2.38 and 3.18mm Face Width ■ 20° Pressure Angle

Pin Hub — 3mm Bore ■ Split Hub — 3mm Bore ■ Hubless — 9.525mm Bore

All Dimensions are millimeters

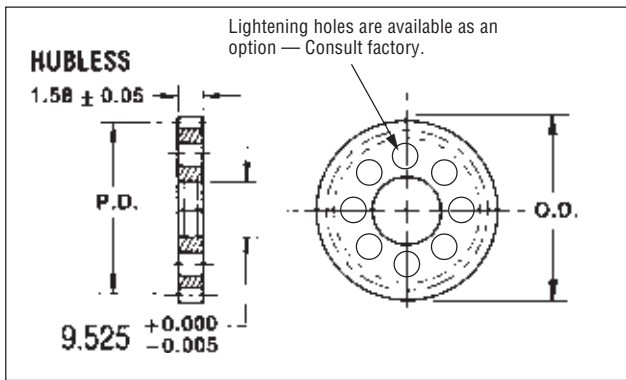
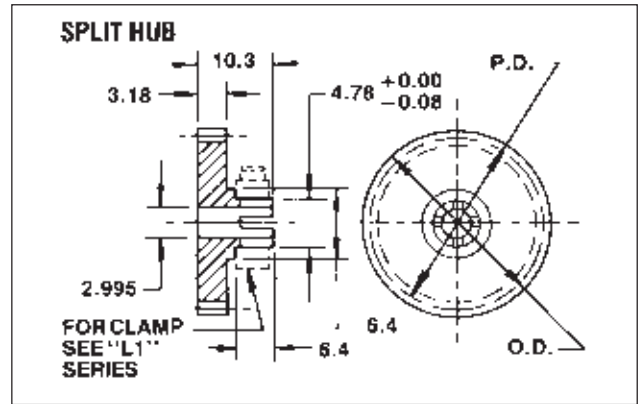
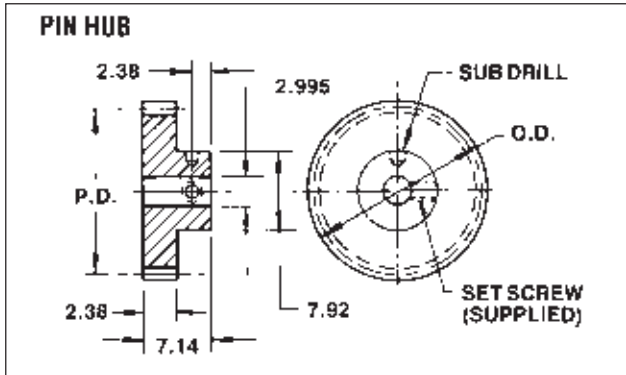

Material: 303 Stainless Steel
2024-T4 Aluminum (Anodized Before Cutting)

Tolerances

Quality Number	T7 *	T8	T5
Bore	+0.013 -0.000	+0.008 -0.000	+0.005 -0.000
Pitch Diameter	+0.000 -0.025	+0.000 -0.018	+0.000 -0.013
Outside Diameter	+0.00 -0.05	+0.00 -0.04	+0.00 -0.03
Total Composite and Teeth to Tooth Tolerance	Refer to Technical Reference 12-2		

* Standard Quality Level —
No suffix on part number when ordering standard quality level. i.e. **MSG3-24**
Specify quality level for T6 / T5 orders. i.e. **MSG3-24-T5**

For Gear Hubs See Pages 12-67 & 12-68

Gear Data			Stainless Steel Part No.			Aluminum Part No.		
No. Teeth	Pitch Dia.	Outside Dia.	Pin Hub	Split Hub	Hubless	Pin Hub	Split Hub	Hubless
124	6.0	6.5	MSG3-24	MSG35-24	—	MSG4-24	MSG36-24	—
126	7.0	7.5	MSG3-28	MSG35-28	—	MSG4-28	MSG36-28	—
32	8.0	8.5	MSG3-32	MSG35-32	—	MSG4-32	MSG36-32	—
36	9.0	9.5	MSG3-36	MSG35-36	—	MSG4-36	MSG36-36	—
40	10.0	10.5	MSG3-40	MSG35-40	—	MSG4-40	MSG36-40	—
48	12.0	12.5	MSG3-48	MSG35-48	—	MSG4-48	MSG36-48	—
54	13.5	14.0	MSG3-54	MSG35-54	—	MSG4-54	MSG36-54	—
60	15.0	15.5	MSG3-60	MSG35-60	MHS1-60	MSG4-60	MSG36-60	MHS2-60
72	18.0	18.5	MSG3-72	MSG35-72	MHS1-72	MSG4-72	MSG36-72	MHS2-72
84	21.0	21.5	MSG3-84	MSG35-84	MHS1-84	MSG4-84	MSG36-84	MHS2-84
96	24.0	24.5	MSG3-96	MSG35-96	MHS1-96	MSG4-96	MSG36-96	MHS2-96
100	25.0	25.5	MSG3-100	MSG35-100	MHS1-100	MSG4-100	MSG36-100	MHS2-100
120	30.0	30.5	MSG3-120	MSG35-120	MHS1-120	MSG4-120	MSG36-120	MHS2-120
132	33.0	33.5	MSG3-132	—	MHS1-132	MSG4-132	—	MHS2-132
144	36.0	36.5	MSG3-144	—	MHS1-144	MSG4-144	—	MHS2-144
168	42.0	42.5	MSG3-168	—	MHS1-168	MSG4-168	—	MHS2-168
180	45.0	45.5	MSG3-180	—	MHS1-180	MSG4-180	—	MHS2-180
192	48.0	48.5	MSG3-192	—	MHS1-192	MSG4-192	—	MHS2-192
216	54.0	54.5	—	—	MHS1-216	—	—	MHS2-216
240	60.0	60.5	—	—	MHS1-240	—	—	MHS2-240
264	66.0	66.5	—	—	MHS1-264	—	—	MHS2-264
288	72.0	72.5	—	—	MHS1-288	—	—	MHS2-288

Other Bore Sizes Available. Consult Factory.

For gears with a number of teeth not shown within the range listed above, substitute the required number of teeth for the digits at the end of the Part Number.
Pricing can be determined by using our online E-Commerce price list for the next higher published part number in the listing.

SPUR GEARS — 0.3 Module ■ 3.18mm Face Width ■ 20° Pressure Angle

Pin Hub — 3mm Bore ■ Split Hub — 3mm Bore ■ Hubless — 9.525mm Bore

All Dimensions in Millimeters

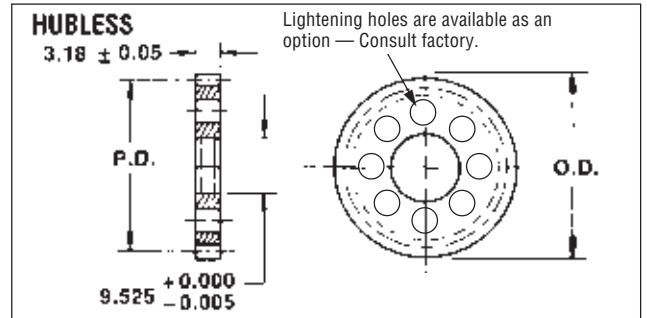
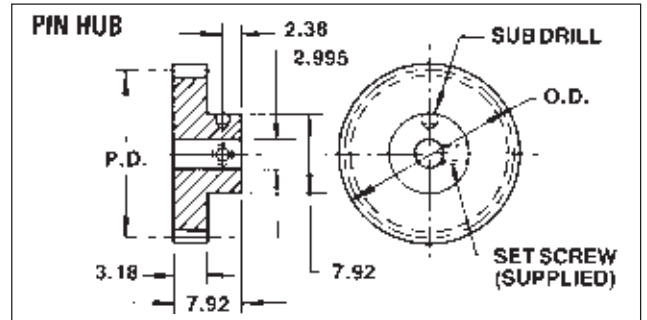
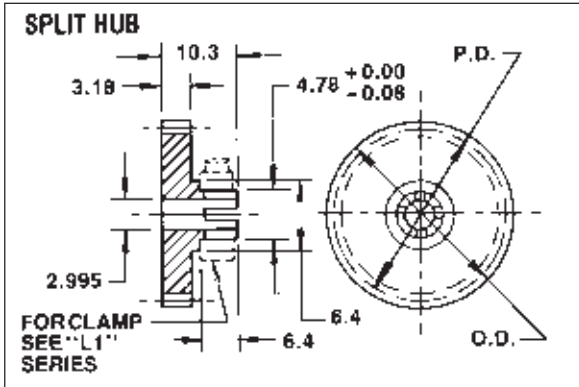

Material: 303 Stainless Steel
2024-T4 Aluminum (Anodized Before Cutting)

For Gear Hubs See Pages 12-67 & 12-68

Gear Data			Stainless Steel Part No.			Aluminum Part No.		
No. Teeth	Pitch Dia.	Outside Dia.	Pin Hub	Split Hub	Hubless	Pin Hub	Split Hub	Hubless
120	6.0	6.6	MSG5-20	—	—	MSG6-20	—	—
124	7.2	7.8	MSG5-24	—	—	MSG6-24	—	—
125	7.5	8.1	MSG5-25	—	—	MSG6-25	—	—
126	7.8	8.4	MSG5-26	—	—	MSG6-26	—	—
127	8.1	8.7	MSG5-27	MSG37-27	—	MSG6-27	MSG38-27	—
130	9.0	9.6	MSG5-30	MSG37-30	—	MSG6-30	MSG38-30	—
132	9.6	10.2	MSG5-32	MSG37-32	—	MSG6-32	MSG38-32	—
134	10.2	10.8	MSG5-34	MSG37-34	—	MSG6-34	MSG38-34	—
35	10.5	11.1	MSG5-35	MSG37-35	—	MSG6-35	MSG38-35	—
36	10.8	11.4	MSG5-36	MSG37-36	—	MSG6-36	MSG38-36	—
40	12.0	12.6	MSG5-40	MSG37-40	—	MSG6-40	MSG38-40	—
50	15.0	15.6	MSG5-50	MSG37-50	—	MSG6-50	MSG38-50	—
55	16.5	17.1	MSG5-55	MSG37-55	MHS3-55	MSG6-55	MSG38-55	MHS4-55
60	18.0	18.6	MSG5-60	MSG37-60	MHS3-60	MSG6-60	MSG38-60	MHS4-60
70	21.0	21.6	MSG5-70	MSG37-70	MHS3-70	MSG6-70	MSG38-70	MHS4-70
75	22.5	23.1	MSG5-75	MSG37-75	MHS3-75	MSG6-75	MSG38-75	MHS4-75
80	24.0	24.6	MSG5-80	MSG37-80	MHS3-80	MSG6-80	MSG38-80	MHS4-80
85	25.5	26.1	MSG5-85	MSG37-85	MHS3-85	MSG6-85	MSG38-85	MHS4-85
90	27.0	27.6	MSG5-90	MSG37-90	MHS3-90	MSG6-90	MSG38-90	MHS4-90
100	30.0	30.6	MSG5-100	MSG37-100	MHS3-100	MSG6-100	MSG38-100	MHS4-100
110	33.0	33.6	MSG5-110	MSG37-110	MHS3-110	MSG6-110	MSG38-110	MHS4-110
120	36.0	36.6	MSG5-120	MSG37-120	MHS3-120	MSG6-120	MSG38-120	MHS4-120
130	39.0	39.6	MSG5-130	—	MHS3-130	MSG6-130	—	MHS4-130
140	42.0	42.6	MSG5-140	—	MHS3-140	MSG6-140	—	MHS4-140
150	45.0	45.6	MSG5-150	—	MHS3-150	MSG6-150	—	MHS4-150
160	48.0	48.6	MSG5-160	—	MHS3-160	MSG6-160	—	MHS4-160
170	51.0	51.6	MSG5-170	—	MHS3-170	MSG6-170	—	MHS4-170
180	54.0	54.6	MSG5-180	—	MHS3-180	MSG6-180	—	MHS4-180
200	60.0	60.6	—	—	MHS3-200	—	—	MHS4-200
216	64.8	65.4	—	—	MHS3-216	—	—	MHS4-216
240	72.0	72.6	—	—	MHS3-240	—	—	MHS4-240
260	78.0	78.6	—	—	MHS3-260	—	—	MHS4-260
320	96.0	96.6	—	—	MHS3-320	—	—	MHS4-320

Tolerances

Quantity Number	T7 *	T8	T5
Bore	+0.013 -0.000	+0.008 -0.000	+0.005 -0.000
Pitch Diameter	+0.000 -0.025	+0.000 -0.018	+0.000 -0.013
Outside Diameter	+0.30 -0.05	+0.00 -0.04	+0.00 -0.03
Total Composite and Tooth to Tooth Tolerance	Refer to Technical Reference 12-2		

* Standard Quality Level —

No suffix on part number when ordering standard quality level. i.e. MHS3-60
Specify quality level for T6 / T5 orders. i.e. MHS3-60-T5

For gears with a number of teeth not shown within the range listed above, substitute the required number of teeth for the digits at the end of the Part Number.

Pricing can be determined by using our online E-Commerce price list for the next higher published part number in the listing.

† Hub Gears into Hub

Other Bore Sizes Available, Consult Factory.

SPUR GEARS — 0.4 Module ■ 3.18mm Face Width ■ 20° Pressure Angle

Pin Hub — 3 and 4mm Bores

All Dimensions in Millimeters

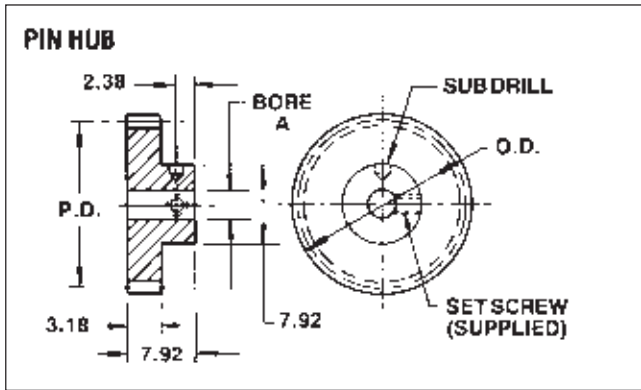

Material: 303 Stainless Steel
2024-T4 Aluminum (Anodized Before Cutting)

Dimen.	Bore	
	3 mm	4 mm
A	2.355	3.935

Tolerances

Quality Number	T7 *	T8	T5
Bore	+0.013 -0.000	+0.008 -0.000	+0.005 -0.000
Pitch Diameter	+0.000 -0.025	+0.000 -0.018	+0.000 -0.013
Outside Diameter	+0.00 -0.05	+0.00 -0.04	+0.00 -0.03
Total Composite and Tooth to Tooth Tolerances	Refer to Technical Reference 12-2		

* Standard Quality Level —

No suffix on part number when ordering standard quality level. i.e. **MSG7-25**

Specify quality level for T6 / T5 orders. i.e. **MSG7-25-T5**

Gear Data			Stainless Steel Part No.		Aluminum Part No.	
No. Teeth	Pitch Dia.	Outside Dia.	3 mm Bore	4 mm Bore	3 mm Bore	4 mm Bore
24	9.6	10.4	MSG7-24	MSG9-24	MSG8-24	MSG10-24
25	10.0	10.6	MSG7-25	MSG9-25	MSG8-25	MSG10-25
26	10.4	11.2	MSG7-26	MSG9-26	MSG8-26	MSG10-26
28	11.2	12.0	MSG7-28	MSG9-28	MSG8-28	MSG10-28
30	12.0	12.8	MSG7-30	MSG9-30	MSG8-30	MSG10-30
32	12.8	13.6	MSG7-32	MSG9-32	MSG8-32	MSG10-32
36	14.4	15.2	MSG7-36	MSG9-36	MSG8-36	MSG10-36
40	16.0	16.8	MSG7-40	MSG9-40	MSG8-40	MSG10-40
42	16.8	17.6	MSG7-42	MSG9-42	MSG8-42	MSG10-42
44	17.6	18.4	MSG7-44	MSG9-44	MSG8-44	MSG10-44
46	18.4	19.2	MSG7-46	MSG9-46	MSG8-46	MSG10-46
48	19.2	20.0	MSG7-48	MSG9-48	MSG8-48	MSG10-48
50	20.0	20.8	MSG7-50	MSG9-50	MSG8-50	MSG10-50
60	24.0	24.8	MSG7-60	MSG9-60	MSG8-60	MSG10-60
64	25.6	26.4	MSG7-64	MSG9-64	MSG8-64	MSG10-64
70	28.0	28.8	MSG7-70	MSG9-70	MSG8-70	MSG10-70
72	28.8	29.6	MSG7-72	MSG9-72	MSG8-72	MSG10-72
75	30.0	30.8	MSG7-75	MSG9-75	MSG8-75	MSG10-75
80	32.0	32.8	MSG7-80	MSG9-80	MSG8-80	MSG10-80
84	33.6	34.4	MSG7-84	MSG9-84	MSG8-84	MSG10-84
85	34.0	34.8	MSG7-85	MSG9-85	MSG8-85	MSG10-85
90	36.0	36.8	MSG7-90	MSG9-90	MSG8-90	MSG10-90
95	38.0	38.8	MSG7-95	MSG9-95	MSG8-95	MSG10-95
96	38.4	39.2	MSG7-96	MSG9-96	MSG8-96	MSG10-96
100	40.0	40.8	MSG7-100	MSG9-100	MSG8-100	MSG10-100
105	42.0	42.8	MSG7-105	MSG9-105	MSG8-105	MSG10-105
120	48.0	48.8	MSG7-120	MSG9-120	MSG8-120	MSG10-120
160	64.0	64.8	MSG7-160	MSG9-160	MSG8-160	MSG10-160

Other Bore Sizes Available. Consult Factory

For gears with a number of teeth not shown within the range listed above, substitute the required number of teeth for the digits at the end of the Part Number.

Pricing can be determined by using our online E-Commerce price list for the next higher published part number in the listing.

SPUR GEARS — 0.4 Module ■ 3.18 and 4.76mm Face Width ■ 20° Pressure Angle

Pin Hub — 6mm Bore

All Dimensions in Millimeters

Gear Data			Stainless Steel Part No.		Aluminum Part No.	
No. Teeth	Pitch Dia.	Outside Dia.	3.18 mm Face	4.76 mm Face	3.18 mm Face	4.76 mm Face
126	10.4	11.2	MSG11-26	MSG13-26	MSG12-26	MSG14-26
129	11.6	12.4	MSG11-29	MSG13-29	MSG12-29	MSG14-29
130	12.0	12.8	MSG11-30	MSG13-30	MSG12-30	MSG14-30
132	12.8	13.6	MSG11-32	MSG13-32	MSG12-32	MSG14-32
36	14.4	15.2	MSG11-36	MSG13-36	MSG12-36	MSG14-36
40	16.0	16.8	MSG11-40	MSG13-40	MSG12-40	MSG14-40
42	16.8	17.6	MSG11-42	MSG13-42	MSG12-42	MSG14-42
48	19.2	20.0	MSG11-48	MSG13-48	MSG12-48	MSG14-48
50	20.0	20.8	MSG11-50	MSG13-50	MSG12-50	MSG14-50
55	22.0	22.8	MSG11-55	MSG13-55	MSG12-55	MSG14-55
56	22.4	23.2	MSG11-56	MSG13-56	MSG12-56	MSG14-56
60	24.0	24.8	MSG11-60	MSG13-60	MSG12-60	MSG14-60
64	25.6	26.4	MSG11-64	MSG13-64	MSG12-64	MSG14-64
72	28.8	29.6	MSG11-72	MSG13-72	MSG12-72	MSG14-72
75	30.0	30.8	MSG11-75	MSG13-75	MSG12-75	MSG14-75
80	32.0	32.8	MSG11-80	MSG13-80	MSG12-80	MSG14-80
84	33.6	34.4	MSG11-84	MSG13-84	MSG12-84	MSG14-84
85	34.0	34.8	MSG11-85	MSG13-85	MSG12-85	MSG14-85
88	35.2	36.0	MSG11-88	MSG13-88	MSG12-88	MSG14-88
96	38.4	39.2	MSG11-96	MSG13-96	MSG12-96	MSG14-96
100	40.0	40.8	MSG11-100	MSG13-100	MSG12-100	MSG14-100
104	41.6	42.4	MSG11-104	MSG13-104	MSG12-104	MSG14-104
112	44.8	45.6	MSG11-112	MSG13-112	MSG12-112	MSG14-112
120	48.0	48.8	MSG11-120	MSG13-120	MSG12-120	MSG14-120
127	50.8	51.6	MSG11-127	MSG13-127	MSG12-127	MSG14-127
140	56.0	56.8	MSG11-140	MSG13-140	MSG12-140	MSG14-140
144	57.6	58.4	MSG11-144	MSG13-144	MSG12-144	MSG14-144
160	64.0	64.8	MSG11-160	MSG13-160	MSG12-160	MSG14-160

Flute Cuts Into Hub

Other Bore Sizes Available Consult Factory

For gears with a number of teeth not shown within the range listed above, substitute the required number of teeth for the digits at the end of the Part Number.

Pricing can be determined by using our online E-Commerce price list for the next higher published part number in the listing.

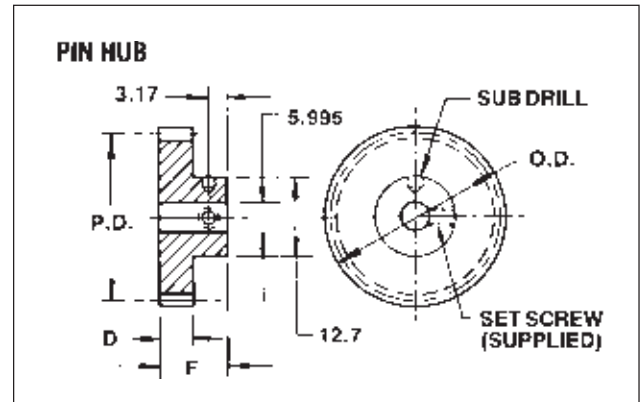

Material: 303 Stainless Steel

2024-T4 Aluminum (Anodized Before Cutting)

Dimen.		
D	3.18	4.76
F	9.52	11.13

Tolerances

Quality Number	T7 *	T6	T5
Bore	+0.013	+0.008	+0.005
	-0.000	-0.000	-0.000
Pitch Diameter	+0.000	+0.000	+0.000
	-0.025	-0.018	-0.013
Outside Diameter	+0.06	+0.00	+0.00
	-0.05	-0.04	0.03
Total Composite and Tooth to Tooth Tolerances	Refer to Technical Reference 12-2		

* Standard Quality Level —

No suffix on part number when ordering standard quality level. i.e. **MSG11-26**

Specify quality level for T6 / T5 orders. i.e. **MSG11-26-T5**

SPUR GEARS — 0.4 Module ■ 3.18mm Face Width ■ 20° Pressure Angle

Split Hub — 4 and 6mm Bores ■ Hubless — 9.52mm Bore

All Dimensions in Millimeters

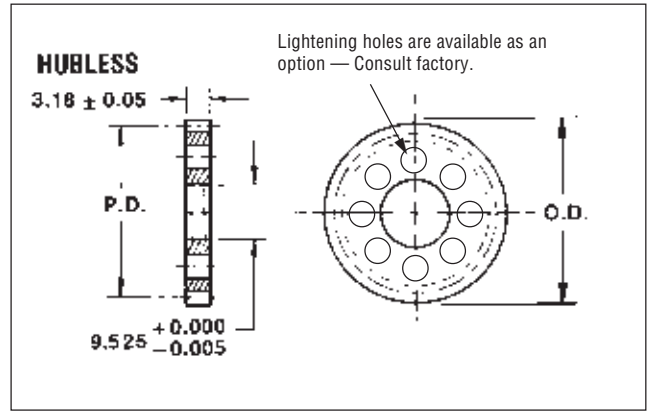
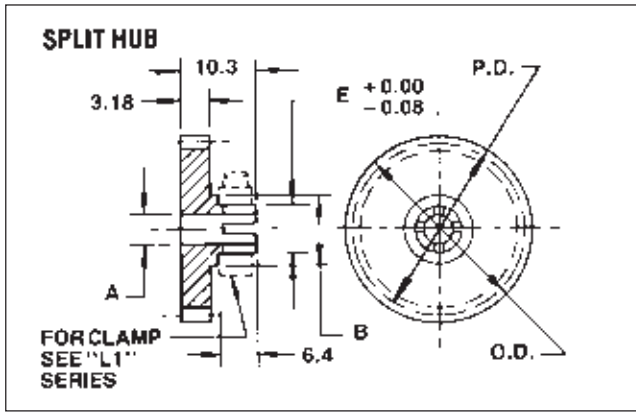

Material: 303 Stainless Steel
2024-T4 Aluminum (Anodized Before Cutting)

Dim	Bore	
	4	6
A	3.995	5.995
B	7.92	9.52
C	6.4	7.92

Tolerances

Quality Number	T7 *	T8	T5
	Bore	+0.013 -0.000	+0.008 -0.000
Pitch Diameter	+0.000 -0.025	+0.000 -0.018	+0.000 -0.013
Outside Diameter	+0.00 -0.05	+0.00 -0.04	+0.00 -0.03
Total Composite and Teeth to Tooth Tolerance	Refer to Technical Reference 12-2		

* Standard Quality Level —
No suffix on part number when ordering standard quality level. i.e. **MHS6-48**
Specify quality level for T6 / T5 orders. i.e. **MHS6-48-T5**

Gear Data	Stainless Steel Part No.						Aluminum Part No.		
	No. Teeth	Pitch Dia.	Outside Dia.	Split Hub		Hubless	Split Hub		Hubless
				4 mm Bore	6 mm Bore	9.525 Bore	4 mm Bore	6 mm Bore	9.525 Bore
22	8.8	9.6	MSG39-22	MSG41-22	—	MSG40-22	MSG42-22	—	
24	9.6	10.4	MSG39-24	MSG41-24	—	MSG40-24	MSG42-24	—	
25	10.0	10.8	MSG39-25	MSG41-25	—	MSG40-25	MSG42-25	—	
30	12.0	12.8	MSG39-30	MSG41-30	—	MSG40-30	MSG42-30	—	
32	12.8	13.6	MSG39-32	MSG41-32	—	MSG40-32	MSG42-32	—	
36	14.4	15.2	MSG39-36	MSG41-36	—	MSG40-36	MSG42-36	—	
38	15.2	16.0	MSG39-38	MSG41-38	—	MSG40-38	MSG42-38	—	
40	16.0	16.8	MSG39-40	MSG41-40	—	MSG40-40	MSG42-40	—	
48	19.2	20.0	MSG39-48	MSG41-48	MHS5-48	MSG40-48	MSG42-48	MHS6-48	
50	20.0	20.8	MSG39-50	MSG41-50	MHS5-50	MSG40-50	MSG42-50	MHS6-50	
56	22.4	23.2	MSG39-56	MSG41-56	MHS5-56	MSG40-56	MSG42-56	MHS6-56	
60	24.0	24.8	MSG39-60	MSG41-60	MHS5-60	MSG40-60	MSG42-60	MHS6-60	
64	25.6	26.4	MSG39-64	MSG41-64	MHS5-64	MSG40-64	MSG42-64	MHS6-64	
72	28.8	29.6	MSG39-72	MSG41-72	MHS5-72	MSG40-72	MSG42-72	MHS6-72	
80	32.0	32.8	MSG39-80	MSG41-80	MHS5-80	MSG40-80	MSG42-80	MHS6-80	
96	38.4	39.2	MSG39-96	MSG41-96	MHS5-96	MSG40-96	MSG42-96	MHS6-96	
104	41.6	42.4	MSG39-104	MSG41-104	MHS5-104	MSG40-104	MSG42-104	MHS6-104	
112	44.8	45.6	MSG39-112	MSG41-112	MHS5-112	MSG40-112	MSG42-112	MHS6-112	
120	48.0	48.8	—	MSG41-120	MHS5-120	—	MSG42-120	MHS6-120	
127	50.8	51.6	—	MSG41-127	MHS5-127	—	MSG42-127	MHS6-127	
144	57.6	58.4	—	MSG41-144	MHS5-144	—	MSG42-144	MHS6-144	
160	64.0	64.8	—	MSG41-160	MHS5-160	—	MSG42-160	MHS6-160	
176	70.4	71.2	—	MSG41-176	MHS5-176	—	MSG42-176	MHS6-176	
192	76.8	77.6	—	MSG41-192	MHS5-192	—	MSG42-192	MHS6-192	
224	89.6	90.4	—	MSG41-224	—	—	MSG42-224	—	
240	96.0	96.8	—	MSG41-240	—	—	MSG42-240	—	

†Hob Cuts Into Hub
Other Bore Sizes Available. Consult Factory

For gears with a number of teeth not shown within the range listed above, substitute the required number of teeth for the digits at the end of the Part Number.
Pricing can be determined by using our online E-Commerce price list for the next higher published part number in the listing.

For Gear Hubs See Pages 12-67 & 12-68

SPUR GEARS — 0.5 Module ■ 3.18mm Face Width ■ 20° Pressure Angle

Pin Hub — 3 and 4mm Bores

All Dimensions in Millimeters

Gear Data			Stainless Steel Part No.		Aluminum Part No.	
No. Teeth	Pitch Dia.	Outside Dia.	3 mm Bore	4 mm Bore	3 mm Bore	4 mm Bore
14	7.0	8.0	MSG15-14	MSG17-14	MSG16-14	MSG18-14
16	8.0	9.0	MSG15-16	MSG17-16	MSG16-16	MSG18-16
18	9.0	10.0	MSG15-18	MSG17-18	MSG16-18	MSG18-18
20	10.0	11.0	MSG15-20	MSG17-20	MSG16-20	MSG18-20
21	10.5	11.5	MSG15-21	MSG17-21	MSG16-21	MSG18-21
24	12.0	13.0	MSG15-24	MSG17-24	MSG16-24	MSG18-24
26	13.0	14.0	MSG15-26	MSG17-26	MSG16-26	MSG18-26
27	13.5	14.5	MSG15-27	MSG17-27	MSG16-27	MSG18-27
30	15.0	16.0	MSG15-30	MSG17-30	MSG16-30	MSG18-30
32	16.0	17.0	MSG15-32	MSG17-32	MSG16-32	MSG18-32
36	18.0	19.0	MSG15-36	MSG17-36	MSG16-36	MSG18-36
40	20.0	21.0	MSG15-40	MSG17-40	MSG16-40	MSG18-40
42	21.0	22.0	MSG15-42	MSG17-42	MSG16-42	MSG18-42
48	24.0	25.0	MSG15-48	MSG17-48	MSG16-48	MSG18-48
50	25.0	26.0	MSG15-50	MSG17-50	MSG16-50	MSG18-50
56	27.5	28.5	MSG15-56	MSG17-56	MSG16-56	MSG18-56
60	30.0	31.0	MSG15-60	MSG17-60	MSG16-60	MSG18-60
64	32.0	33.0	MSG15-64	MSG17-64	MSG16-64	MSG18-64
72	36.0	37.0	MSG15-72	MSG17-72	MSG16-72	MSG18-72
75	37.5	38.5	MSG15-75	MSG17-75	MSG16-75	MSG18-75
80	40.0	41.0	MSG15-80	MSG17-80	MSG16-80	MSG18-80
84	42.0	43.0	MSG15-84	MSG17-84	MSG16-84	MSG18-84
90	45.0	46.0	MSG15-90	MSG17-90	MSG16-90	MSG18-90
96	48.0	49.0	MSG15-96	MSG17-96	MSG16-96	MSG18-96
100	50.0	51.0	MSG15-100	MSG17-100	MSG16-100	MSG18-100
120	60.0	61.0	MSG15-120	MSG17-120	MSG16-120	MSG18-120
144	72.0	73.0	MSG15-144	MSG17-144	MSG16-144	MSG18-144
180	90.0	91.0	MSG15-180	MSG17-180	MSG16-180	MSG18-180

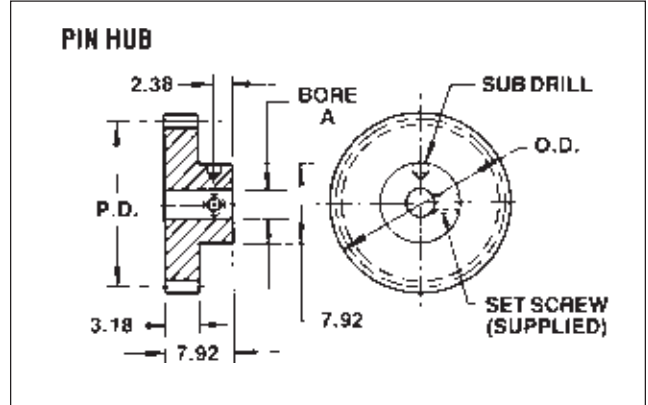

Material: 303 Stainless Steel
2024-T4 Aluminum (Anodized Before Cutting)

Dimen.	Bore	
	3 mm	4 mm
A	2.995	3.995

1Hob Cuts Into Hub

Other Bore Sizes Available, Consult Factory

For gears with a number of teeth not shown within the range listed above, substitute the required number of teeth for the digits at the end of the Part Number.

Pricing can be determined by using our online E-Commerce price list for the next higher published part number in the listing.

Tolerances

Quality Number	T7 *	T6	T5
Bore	+0.013 -0.000	+0.008 -0.000	+0.005 -0.000
Pitch Diameter	+0.000 -0.025	+0.000 -0.018	+0.000 -0.013
Outside Diameter	+0.00 -0.05	+0.00 -0.04	+0.00 -0.03
Total Composite and Tooth to Tooth Tolerance	Refer to Technical Reference 12-2		

* Standard Quality Level —

No suffix on part number when ordering standard quality level. i.e. **MSG15-60**

Specify quality level for T6 / T5 orders.

i.e. **MSG15-60-T5**

SPUR GEARS — 0.5 Module ■ 3.18 and 4.76mm Face Width ■ 20° Pressure Angle

Pin Hub — 6mm Bore

All Dimensions in Millimeters

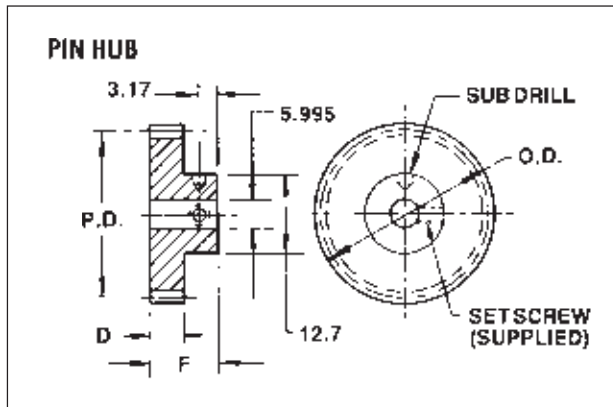

Material: 303 Stainless Steel
2024-T4 Aluminum (Anodized Before Cutting)

Dim	Bore	
	4	6
D	3.18	4.76
F	9.52	11.10

Tolerances

Quality Number	T7*	T6	T5
Bore	+0.013	+0.006	+0.005
	-0.000	-0.000	-0.000
Pitch Diameter	+0.000	+0.000	+0.000
	-0.025	-0.018	-0.013
Outside Diameter	+0.00	+0.00	+0.00
	-0.05	-0.04	-0.03
Total Composite and Tooth to Tooth Tolerance	Refer to Technical Reference 12-2		

* Standard Quality Level —

No suffix on part number when ordering standard quality level. i.e. **MSG19-20**

Specify quality level for T6 / T5 orders. i.e. **MSG19-20-T5**

Gear Data			Stainless Steel Part No.		Aluminum Part No.	
No. Teeth	Pitch Dia.	Outside Dia.	3.18 Face Width	4.76 Face Width	3.18 Face Width	4.76 Face Width
120	10.0	11.0	MSG19-20	MSG21-20	MSG20-20	MSG22-20
122	11.0	12.0	MSG19-22	MSG21-22	MSG20-22	MSG22-22
124	12.0	13.0	MSG19-24	MSG21-24	MSG20-24	MSG22-24
126	13.0	14.0	MSG19-26	MSG21-26	MSG20-26	MSG22-26
30	15.0	16.0	MSG19-30	MSG21-30	MSG20-30	MSG22-30
32	16.0	17.0	MSG19-32	MSG21-32	MSG20-32	MSG22-32
34	17.0	18.0	MSG19-34	MSG21-34	MSG20-34	MSG22-34
36	18.0	19.0	MSG19-36	MSG21-36	MSG20-36	MSG22-36
40	20.0	21.0	MSG19-40	MSG21-40	MSG20-40	MSG22-40
42	21.0	22.0	MSG19-42	MSG21-42	MSG20-42	MSG22-42
48	24.0	25.0	MSG19-48	MSG21-48	MSG20-48	MSG22-48
50	25.0	26.0	MSG19-50	MSG21-50	MSG20-50	MSG22-50
55	27.5	28.5	MSG19-55	MSG21-55	MSG20-55	MSG22-55
60	30.0	31.0	MSG19-60	MSG21-60	MSG20-60	MSG22-60
72	36.0	37.0	MSG19-72	MSG21-72	MSG20-72	MSG22-72
75	37.5	38.5	MSG19-75	MSG21-75	MSG20-75	MSG22-75
80	40.0	41.0	MSG19-80	MSG21-80	MSG20-80	MSG22-80
84	42.0	43.0	MSG19-84	MSG21-84	MSG20-84	MSG22-84
90	45.0	46.0	MSG19-90	MSG21-90	MSG20-90	MSG22-90
96	48.0	49.0	MSG19-96	MSG21-96	MSG20-96	MSG22-96
100	50.0	51.0	MSG19-100	MSG21-100	MSG20-100	MSG22-100
105	52.5	53.5	MSG19-105	MSG21-105	MSG20-105	MSG22-105
110	55.0	56.0	MSG19-110	MSG21-110	MSG20-110	MSG22-110
120	60.0	61.0	MSG19-120	MSG21-120	MSG20-120	MSG22-120
126	63.0	64.0	MSG19-126	MSG21-126	MSG20-126	MSG22-126
144	72.0	73.0	MSG19-144	MSG21-144	MSG20-144	MSG22-144
156	78.0	79.0	MSG19-156	MSG21-156	MSG20-156	MSG22-156
180	90.0	91.0	MSG19-180	MSG21-180	MSG20-180	MSG22-180

Hub Cuts Into Hub.

Other Bore Sizes Available. Consult Factory.

For gears with a number of teeth not shown within the range listed above, substitute the required number of teeth for the digits at the end of the Part Number.

Pricing can be determined by using our online E-Commerce price list for the next higher published part number in the listing.

SPUR GEARS — 0.5 Module ■ 3.18mm Face Width ■ 20° Pressure Angle

Split Hub — 4 and 6mm Bores ■ Hubless — 9.52mm Bore

All Dimensions in Millimeters

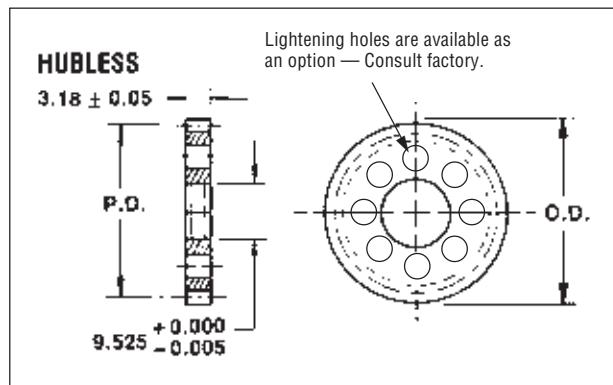
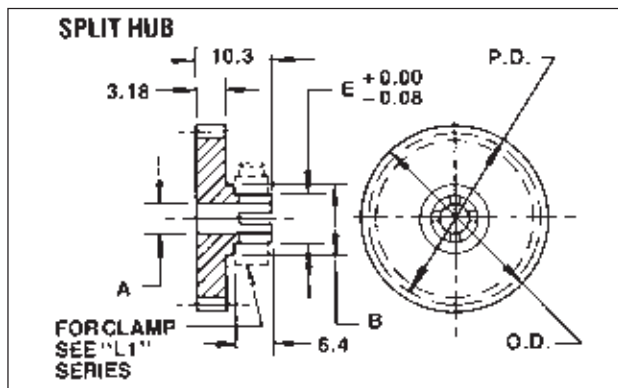

Material: 303 Stainless Steel
2024-T4 Aluminum (Anodized Before Cutting)

Gear Data			Stainless Steel Part No.			Aluminum Part No.		
			Split Hub		Hubless	Split Hub		Hubless
No. Teeth	Pitch Dia.	Outside Dia.	4 mm Bore	6 mm Bore	9.525 mm Bore	4 mm Bore	6 mm Bore	9.525 mm Bore
120	10.0	17.0	MSG43-20	MSG45-20	—	MSG44-20	MSG46-20	—
121	10.5	17.5	MSG43-21	MSG45-21	—	MSG44-21	MSG46-21	—
122	11.0	18.0	MSG43-22	MSG45-22	—	MSG44-22	MSG46-22	—
123	11.5	18.5	MSG43-23	MSG45-23	—	MSG44-23	MSG46-23	—
24	12.0	19.0	MSG43-24	MSG45-24	—	MSG44-24	MSG46-24	—
25	12.5	19.5	MSG43-25	MSG45-25	—	MSG44-25	MSG46-25	—
27	13.5	20.5	MSG43-27	MSG45-27	—	MSG44-27	MSG46-27	—
30	15.0	21.0	MSG43-30	MSG45-30	MHS7-30	MSG44-30	MSG46-30	MHS8-30
32	16.0	22.0	MSG43-32	MSG45-32	MHS7-32	MSG44-32	MSG46-32	MHS8-32
36	18.0	24.0	MSG43-36	MSG45-36	MHS7-36	MSG44-36	MSG46-36	MHS8-36
40	20.0	26.0	MSG43-40	MSG45-40	MHS7-40	MSG44-40	MSG46-40	MHS8-40
42	21.0	27.0	MSG43-42	MSG45-42	MHS7-42	MSG44-42	MSG46-42	MHS8-42
44	22.0	28.0	MSG43-44	MSG45-44	MHS7-44	MSG44-44	MSG46-44	MHS8-44
48	24.0	30.0	MSG43-48	MSG45-48	MHS7-48	MSG44-48	MSG46-48	MHS8-48
55	27.5	35.5	MSG43-55	MSG45-55	MHS7-55	MSG44-55	MSG46-55	MHS8-55
60	30.0	38.0	MSG43-60	MSG45-60	MHS7-60	MSG44-60	MSG46-60	MHS8-60
72	36.0	46.0	MSG43-72	MSG45-72	MHS7-72	MSG44-72	MSG46-72	MHS8-72
78	39.0	50.0	MSG43-78	MSG45-78	MHS7-78	MSG44-78	MSG46-78	MHS8-78
84	42.0	54.0	MSG43-84	MSG45-84	MHS7-84	MSG44-84	MSG46-84	MHS8-84
90	45.0	57.0	MSG43-90	MSG45-90	MHS7-90	MSG44-90	MSG46-90	MHS8-90
96	48.0	60.0	—	MSG45-96	MHS7-96	—	MSG46-96	MHS8-96
108	54.0	69.0	—	MSG45-108	MHS7-108	—	MSG46-108	MHS8-108
120	60.0	75.0	—	MSG45-120	MHS7-120	—	MSG46-120	MHS8-120
127	63.5	79.5	—	MSG45-127	MHS7-127	—	MSG46-127	MHS8-127
132	66.0	82.0	—	MSG45-132	MHS7-132	—	MSG46-132	MHS8-132
165	84.0	102.0	—	MSG45-168	MHS7-168	—	MSG46-168	MHS8-168
192	96.0	120.0	—	MSG45-192	MHS7-192	—	MSG46-192	MHS8-192

Dim	Bore	
	4	6
A	3.995	5.995
B	7.92	9.52
C	6.4	7.92

Tolerances

Quality Number	T7*	T6	T5
Bore	+0.013	+0.008	+0.005
	-0.030	-0.020	-0.010
Pitch Diameter	+0.006	+0.003	+0.001
	-0.025	-0.018	-0.013
Outside Diameter	+0.00	+0.00	+0.00
	-0.05	-0.04	-0.03
Total Composite and Tooth to Tooth Tolerances	Refer to Technical Reference 12-2		

*** Standard Quality Level —**

No suffix on part number when ordering standard quality level. i.e. **MSG43-20**
Specify quality level for T6 / T5 orders. i.e. **MSG43-20-T5**

*Fob Cuts Into H.R.

Other Bore Sizes Available. Consult Factory.

For gears with a number of teeth not shown within the range listed above, substitute the required number of teeth for the digits at the end of the Part Number. Pricing can be determined by using our online E-Commerce price list for the next higher published part number in the listing.

For Gear Hubs See Pages 12-67 & 12-68

SPUR GEARS — 0.6 Module ■ 4.76mm Face Width ■ 20° Pressure Angle

Pin Hub — 6mm Bore

All Dimensions in Millimeters

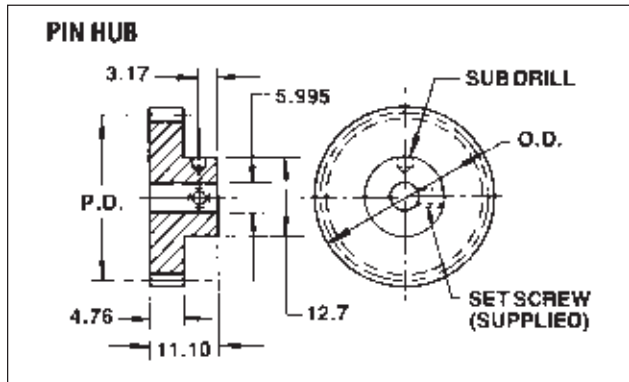

Material: 303 Stainless Steel
2024-T4 Aluminum (Anodized Before Cutting)

Tolerances

Quality Number	T7 *	T6	T5
Bore	+0.013 -0.008	+0.008 0.000	+0.006 -0.000
Pitch Diameter	+0.000 -0.025	+0.000 -0.018	+0.000 -0.013
Outside Diameter	+0.00 -0.05	+0.00 -0.04	+0.00 -0.03
Total Composite and Teeth to Tooth Tolerance	Refer to Technical Reference 12-2		

*** Standard Quality Level —**

No suffix on part number when ordering standard quality level. i.e. **MSG23-16**
Specify quality level for T6 / T5 orders. i.e. **MSG23-16-T5**

Gear Data			Stainless Steel	Aluminum
No. Teeth	Pitch Dia.	Outside Dia.	Part No.	Part No.
†16	9.6	10.8	MSG23-16	MSG24-16
†18	10.8	12.0	MSG23-18	MSG24-18
†20	12.0	13.2	MSG23-20	MSG24-20
†22	13.2	14.4	MSG23-22	MSG24-22
24	14.4	15.6	MSG23-24	MSG24-24
28	16.8	18.0	MSG23-28	MSG24-28
30	18.0	19.2	MSG23-30	MSG24-30
32	19.2	20.4	MSG23-32	MSG24-32
34	20.4	21.6	MSG23-34	MSG24-34
40	24.0	25.2	MSG23-40	MSG24-40
44	26.4	27.6	MSG23-44	MSG24-44
48	28.8	30.0	MSG23-48	MSG24-48
50	30.0	31.2	MSG23-50	MSG24-50
56	33.6	34.8	MSG23-56	MSG24-56
60	36.0	37.2	MSG23-60	MSG24-60
64	38.4	39.6	MSG23-64	MSG24-64
72	43.2	44.4	MSG23-72	MSG24-72
80	48.0	49.2	MSG23-80	MSG24-80
84	50.4	51.6	MSG23-84	MSG24-84
88	52.8	54.0	MSG23-88	MSG24-88
96	57.6	58.8	MSG23-96	MSG24-96
100	60.0	61.2	MSG23-100	MSG24-100
112	67.2	68.4	MSG23-112	MSG24-112
120	72.0	73.2	MSG23-120	MSG24-120

†Hex Cyl Indlg Hub.

Other Bore Sizes Available. Consult Factory

For gears with a number of teeth not shown within the range listed above, substitute the required number of teeth for the digits at the end of the Part Number.

Pricing can be determined by using our online E-Commerce price list for the next higher published part number in the listing.

SPUR GEARS — 0.7 Module ■ 4.76mm Face Width ■ 20° Pressure Angle

Pin Hub — 6mm Bore

No. Teeth	Gear Data		Stainless Steel Part No.	Aluminum Part No.
	Pitch Dia.	Outside Dia.		
16	11.2	12.6	MSG25-16	MSG26-16
18	12.6	14.0	MSG25-18	MSG26-18
20	14.0	15.4	MSG25-20	MSG26-20
22	15.4	16.8	MSG25-22	MSG26-22
24	16.8	18.2	MSG25-24	MSG26-24
28	19.6	21.0	MSG25-28	MSG26-28
30	21.0	22.4	MSG25-30	MSG26-30
32	22.4	23.8	MSG25-32	MSG26-32
34	23.8	25.2	MSG25-34	MSG26-34
40	28.0	29.4	MSG25-40	MSG26-40
44	30.8	32.2	MSG25-44	MSG26-44
45	33.6	35.0	MSG25-45	MSG26-45
50	35.0	36.4	MSG25-50	MSG26-50
56	39.2	40.6	MSG25-56	MSG26-56
60	42.0	43.4	MSG25-60	MSG26-60
64	44.8	46.2	MSG25-64	MSG26-64
72	50.4	51.8	MSG25-72	MSG26-72
80	56.0	57.4	MSG25-80	MSG26-80
84	58.8	60.2	MSG25-84	MSG26-84
88	61.6	63.0	MSG25-88	MSG26-88
96	67.2	68.6	MSG25-96	MSG26-96
100	70.0	71.4	MSG25-100	MSG26-100
112	78.4	79.8	MSG25-112	MSG26-112
120	84.0	85.4	MSG25-120	MSG26-120

Hub Cuts Into Hubs.

Other Bore Sizes Available, Consult Factory.

For gears with a number of teeth not shown within the range listed above, substitute the required number of teeth for the digits at the end of the Part Number.

Pricing can be determined by using our online E-Commerce price list for the next higher published part number in the listing.

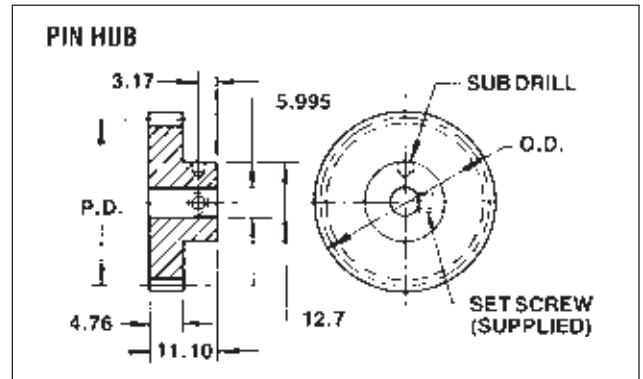

Material: 303 Stainless Steel

2024-T4 Aluminum (Anodized Before Cutting)

Tolerances

Quality Number	T7*	T6	T5
Bore	+0.013 -0.000	+0.008 -0.000	+0.005 -0.000
Pitch Diameter	+0.000 -0.025	+0.000 -0.018	+0.000 -0.013
Outside Diameter	+0.00 0.05	+0.00 -0.04	+0.00 -0.03
Total Composite and Tooth to Tooth Tolerance	Refer to Technical Reference 12-2		

* Standard Quality Level —

No suffix on part number when ordering standard quality level. i.e. **MSG25-16**

Specify quality level for T6 / T5 orders. i.e. **MSG25-16-T5**

SPUR GEARS — 0.8 Module ■ 3.18 and 4.76mm Face Width ■ 20° Pressure Angle

Pin Hub — 6mm Bore ■ Split Hub — 6mm Bore ■ Hubless — 9.52mm Bore

All Dimensions in Millimeters

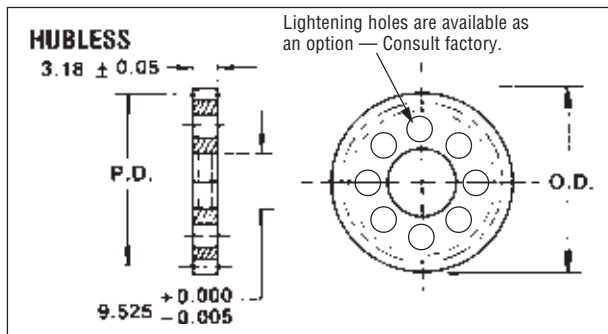
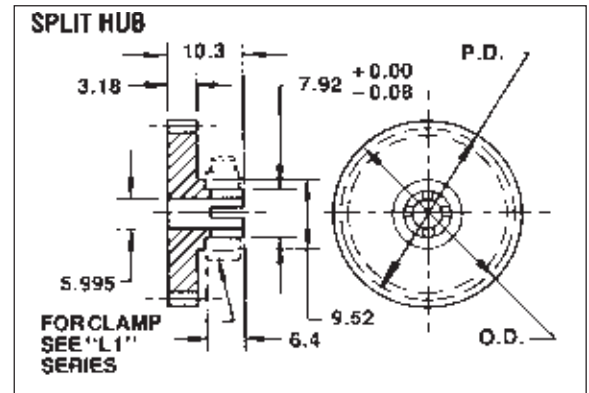
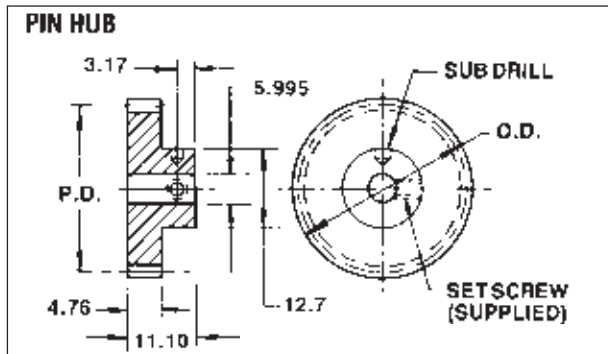

Material: 303 Stainless Steel
2024-T4 Aluminum (Anodized Before Cutting)

For Gear Hubs See Pages 12-67 & 12-68

Tolerances

Quality Number	T7 *	T6	T5
Bore	+0.013 -0.000	+0.008 0.000	+0.006 0.000
Pitch Diameter	+0.000 -0.025	+0.000 0.018	+0.000 0.013
Outside Diameter	+0.00 0.06	+0.00 0.04	+0.00 0.03
Total Composite and Tooth to Tooth Tolerance	Refer to Technical Reference 12-2		

* Standard Quality Level —
No suffix on part number when ordering standard quality level. i.e. MSG27-22
Specify quality level for T6 / T5 orders. i.e. MSG27-22-T5

Gear Data			Stainless Steel Part No.				Aluminum Part No.	
No. Teeth	Pitch Dia.	Outside Dia.	Pin Hub	Split Hub	Hubless	Pin Hub	Split Hub	Hubless
22	17.6	19.2	MSG27-22	—	—	MSG28-22	—	—
24	19.2	20.8	MSG27-24	—	—	MSG28-24	—	—
26	20.8	22.4	MSG27-26	—	—	MSG28-26	—	—
28	22.4	24.0	MSG27-28	—	—	MSG28-28	—	—
30	24.0	25.6	MSG27-30	MSG47-30	MHS9-30	MSG28-30	MSG48-30	MHS10-30
32	25.6	27.2	MSG27-32	MSG47-32	MHS9-32	MSG28-32	MSG48-32	MHS10-32
34	27.2	28.8	MSG27-34	MSG47-34	MHS9-34	MSG28-34	MSG48-34	MHS10-34
36	28.8	30.4	MSG27-36	MSG47-36	MHS9-36	MSG28-36	MSG48-36	MHS10-36
38	30.4	32.0	MSG27-38	MSG47-38	MHS9-38	MSG28-38	MSG48-38	MHS10-38
40	32.0	33.6	MSG27-40	MSG47-40	MHS9-40	MSG28-40	MSG48-40	MHS10-40
44	35.2	36.8	MSG27-44	MSG47-44	MHS9-44	MSG28-44	MSG48-44	MHS10-44
48	38.4	40.0	MSG27-48	MSG47-48	MHS9-48	MSG28-48	MSG48-48	MHS10-48
56	44.8	46.4	MSG27-56	MSG47-56	MHS9-56	MSG28-56	MSG48-56	MHS10-56
60	48.0	49.6	MSG27-60	MSG47-60	MHS9-60	MSG28-60	MSG48-60	MHS10-60
64	51.2	52.8	MSG27-64	MSG47-64	MHS9-64	MSG28-64	MSG48-64	MHS10-64
68	54.4	56.0	MSG27-68	MSG47-68	MHS9-68	MSG28-68	MSG48-68	MHS10-68
72	57.6	59.2	MSG27-72	MSG47-72	MHS9-72	MSG28-72	MSG48-72	MHS10-72
80	64.0	65.6	MSG27-80	MSG47-80	MHS9-80	MSG28-80	MSG48-80	MHS10-80
88	70.4	72.0	MSG27-88	MSG47-88	MHS9-88	MSG28-88	MSG48-88	MHS10-88
96	76.8	78.4	MSG27-96	MSG47-96	MHS9-96	MSG28-96	MSG48-96	MHS10-96
108	86.4	88.0	MSG27-108	MSG47-108	MHS9-108	MSG28-108	MSG48-108	MHS10-108
112	89.6	91.2	MSG27-112	MSG47-112	MHS9-112	MSG28-112	MSG48-112	MHS10-112
128	102.4	104.0	MSG27-128	MSG47-128	MHS9-128	MSG28-128	MSG48-128	MHS10-128
132	105.6	107.2	MSG27-132	MSG47-132	MHS9-132	MSG28-132	MSG48-132	MHS10-132

Other Bore Sizes Available. Consult Factory

For gears with a number of teeth not shown within the range listed above, substitute the required number of teeth for the digits at the end of the Part Number. Pricing can be determined by using our online E-Commerce price list for the next higher published part number in the listing.

SPUR GEARS — 0.8 Module ■ 9.52 Face Width ■ 20° Pressure Angle

DIN Quality 7 ■ Pin Hub — 10mm Bore

All Dimensions in Millimeters

Gear Data			Stainless Steel Part No.	Bronze Part No.
No. Teeth	Pitch Dia.	Outside Dia.		
20	16.0	17.6	MSG29-20	MSG30-20
24	19.2	20.8	MSG29-24	MSG30-24
25	20.0	21.6	MSG29-25	MSG30-25
30	24.0	25.6	MSG29-30	MSG30-30
32	25.6	27.2	MSG29-32	MSG30-32
36	28.8	30.4	MSG29-36	MSG30-36
40	32.0	33.6	MSG29-40	MSG30-40
45	36.0	38.0	MSG29-45	MSG30-45
56	44.8	46.4	MSG29-56	MSG30-56
60	48.0	49.6	MSG29-60	MSG30-60
64	51.2	52.8	MSG29-64	MSG30-64
72	57.6	59.2	MSG29-72	MSG30-72
80	64.0	65.6	MSG29-80	MSG30-80
96	76.8	78.4	MSG29-96	MSG30-96
112	89.6	91.2	MSG29-112	MSG30-112
128	102.4	104.0	MSG29-128	MSG30-128
144	115.2	116.8	MSG29-144	MSG30-144
160	128.0	129.6	MSG29-160	MSG30-160

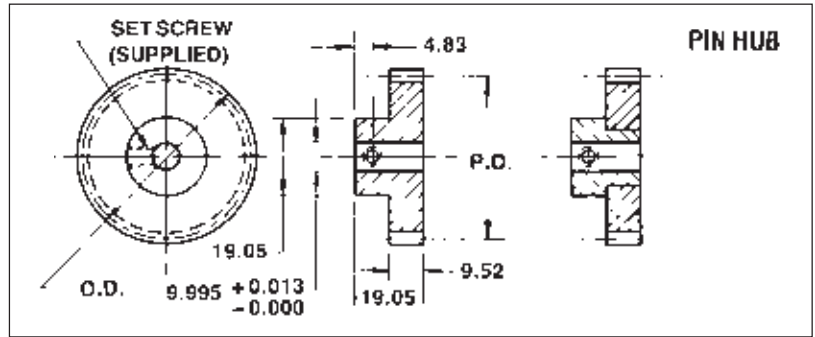

Material: 303 Stainless Steel or Bronze Alloy

Tolerances	Tooth-to-Tooth Composite	Total Composite
Up to 20 Teeth Inclusive	0.018	0.025
Over 20 Teeth — up to 50 Pitch Dia.	0.013	0.025
Over 20 Teeth — 50 to 100 Pitch Dia.	0.013	0.030
Over 20 Teeth — 100 and Over	0.013	0.035

When ordering, Specify Part Number

Example: MSG29-36

Hub Cuts into Hub.

Other Bore Sizes Available. Consult Factory.

For gears with a number of teeth not shown within the range listed above, substitute the required number of teeth for the digits at the end of the Part Number.

Pricing can be determined by using our online E-Commerce price list for the next higher published part number in the listing.

SPUR GEARS — 1.0 Module ■ 9.52 Face Width ■ 20° Pressure Angle

DIN Quality 7 ■ Pin Hub — 10mm Bore

All Dimensions in Millimeters

Gear Data			Stainless Steel Part No.	Bronze Part No.
No. Teeth	Pitch Dia.	Outside Dia.		
115	15.0	17.0	MSG33-15	MSG34-15
116	16.0	18.0	MSG33-16	MSG34-16
118	18.0	20.0	MSG33-18	MSG34-18
120	20.0	22.0	MSG33-20	MSG34-20
24	24.0	26.0	MSG33-24	MSG34-24
28	28.0	30.0	MSG33-28	MSG34-28
30	30.0	32.0	MSG33-30	MSG34-30
36	36.0	38.0	MSG33-36	MSG34-36
40	40.0	42.0	MSG33-40	MSG34-40
48	48.0	50.0	MSG33-48	MSG34-48
56	56.0	58.0	MSG33-56	MSG34-56
60	60.0	62.0	MSG33-60	MSG34-60
72	72.0	74.0	MSG33-72	MSG34-72
80	80.0	82.0	MSG33-80	MSG34-80
96	96.0	98.0	MSG33-96	MSG34-96
112	112.0	114.0	MSG33-112	MSG34-112
120	120.0	122.0	MSG33-120	MSG34-120

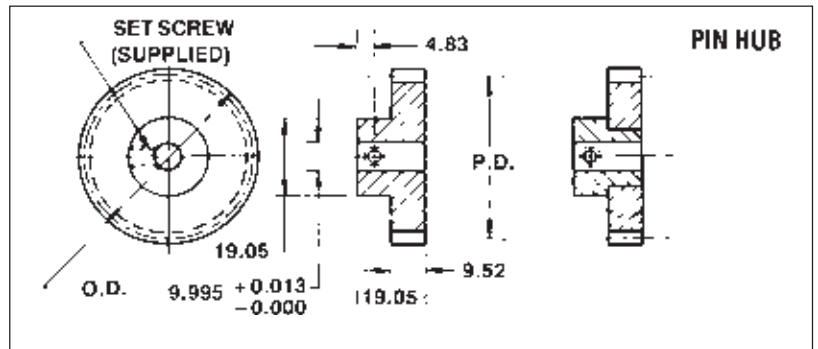

Material: 303 Stainless Steel

Tolerances	Tooth-to-Tooth Composite	Total Composite
Up to 20 Teeth Inclusive	0.018	0.025
Over 20 Teeth — up to 50 Pitch Dia.	0.013	0.025
Over 20 Teeth — 50 to 100 Pitch Dia.	0.013	0.030
Over 20 Teeth — 100 and Over	0.013	0.035

When ordering, Specify Part Number

Example: MSG33-30

Hub Cuts into Hub.

Other Bore Sizes Available. Consult Factory.

For gears with a number of teeth not shown within the range listed above, substitute the required number of teeth for the digits at the end of the Part Number.

Pricing can be determined by using our online E-Commerce price list for the next higher published part number in the listing.

SPUR GEARS — 1.0 Module ■ 3.18 and 4.76mm Face Width ■ 20° Pressure Angle

Pin Hub — 6mm Bore ■ Split Hub — 6mm Bore ■ Hubless — 9.52mm Bore

All Dimensions in Millimeters

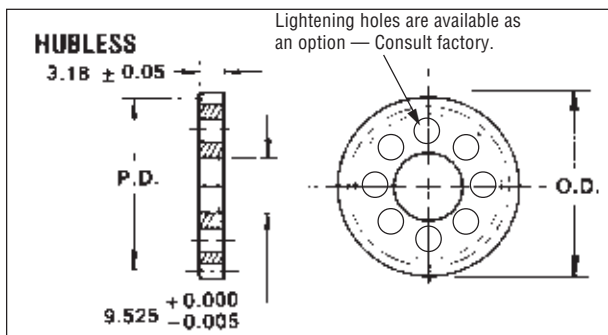
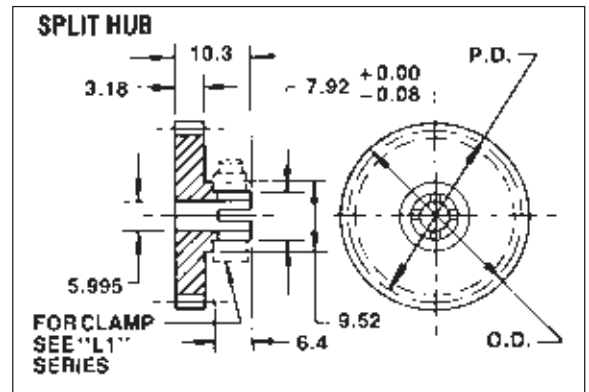
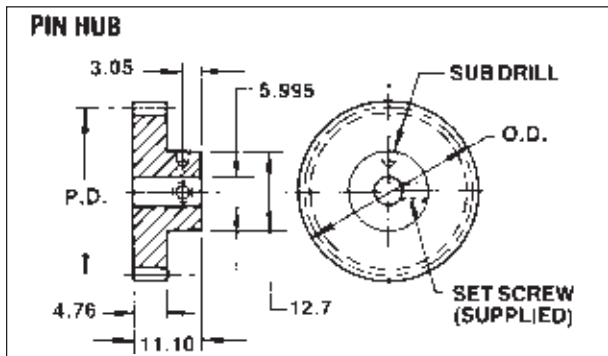

Material 303 Stainless Steel
2024-T4 Aluminum (Anodized Before Cutting)

For Gear Hubs See Pages 12-67 & 12-68

Tolerances

Quality Number	T7	T8	T5
Bore	+0.013 -0.000	+0.008 -0.000	+0.005 -0.000
Pitch Diameter	-0.000 -0.025	-0.000 -0.018	+0.000 -0.015
Outside Diameter	+0.00 -0.06	+0.00 -0.04	+0.00 -0.03
Total Composite and Teeth to Tooth Tolerance	Refer to Technical Reference 12-2		

When ordering, Specify Part Number and Quality Number.
EXAMPLE MSG31-30-T7

To order Oik Quality 5, 6, or 7 add -T5, -T6 or -T7 respectively to part number.

Gear Data			Stainless Steel Part No.			Aluminum Part No.		
No. Teeth	Pitch Dia.	Outside Dia.	Pin Hub	Split Hub	Hubless	Pin Hub	Split Hub	Hubless
10	10.0	12.0	MSG31-10	—	—	MSG32-10	—	—
12	12.0	14.0	MSG31-12	—	—	MSG32-12	—	—
15	15.0	17.0	MSG31-15	—	—	MSG32-15	—	—
16	16.0	18.0	MSG31-16	—	—	MSG32-16	—	—
18	18.0	20.0	MSG31-18	MSG49-18	MHS11-18	MSG32-18	MSG50-18	MHS12-18
20	20.0	22.0	MSG31-20	MSG49-20	MHS11-20	MSG32-20	MSG50-20	MHS12-20
21	21.0	23.0	MSG31-21	MSG49-21	MHS11-21	MSG32-21	MSG50-21	MHS12-21
24	24.0	26.0	MSG31-24	MSG49-24	MHS11-24	MSG32-24	MSG50-24	MHS12-24
27	27.0	29.0	MSG31-27	MSG49-27	MHS11-27	MSG32-27	MSG50-27	MHS12-27
30	30.0	32.0	MSG31-30	MSG49-30	MHS11-30	MSG32-30	MSG50-30	MHS12-30
36	36.0	38.0	MSG31-36	MSG49-36	MHS11-36	MSG32-36	MSG50-36	MHS12-36
39	39.0	41.0	MSG31-39	MSG49-39	MHS11-39	MSG32-39	MSG50-39	MHS12-39
42	42.0	44.0	MSG31-42	MSG49-42	MHS11-42	MSG32-42	MSG50-42	MHS12-42
48	48.0	50.0	MSG31-48	MSG49-48	MHS11-48	MSG32-48	MSG50-48	MHS12-48
51	51.0	53.0	MSG31-51	MSG49-51	MHS11-51	MSG32-51	MSG50-51	MHS12-51
60	60.0	62.0	MSG31-60	MSG49-60	MHS11-60	MSG32-60	MSG50-60	MHS12-60
72	72.0	74.0	MSG31-72	MSG49-72	MHS11-72	MSG32-72	MSG50-72	MHS12-72
75	75.0	77.0	MSG31-75	MSG49-75	MHS11-75	MSG32-75	MSG50-75	MHS12-75
81	81.0	83.0	MSG31-81	MSG49-81	MHS11-81	MSG32-81	MSG50-81	MHS12-81
84	84.0	86.0	MSG31-84	MSG49-84	MHS11-84	MSG32-84	MSG50-84	MHS12-84
87	87.0	89.0	MSG31-87	MSG49-87	MHS11-87	MSG32-87	MSG50-87	MHS12-87
96	96.0	98.0	MSG31-96	MSG49-96	MHS11-96	MSG32-96	MSG50-96	MHS12-96
99	99.0	101.0	MSG31-99	MSG49-99	MHS11-99	MSG32-99	MSG50-99	MHS12-99
100	100.0	102.0	MSG31-100	MSG49-100	MHS11-100	MSG32-100	MSG50-100	MHS12-100

Hub Cuts Into Hub

Other Bore Sizes Available. Consult Factory.

For gears with a number of teeth not shown within the range listed above, substitute the required number of teeth for the digits at the end of the Part Number.

Pricing can be determined by using our online E-Commerce price list for the next higher published part number in the listing.

GEAR & DIAL HUB-PIN TYPE — 1/8", 3/16" and 1/4" = 3, 4 & 6mm Bores

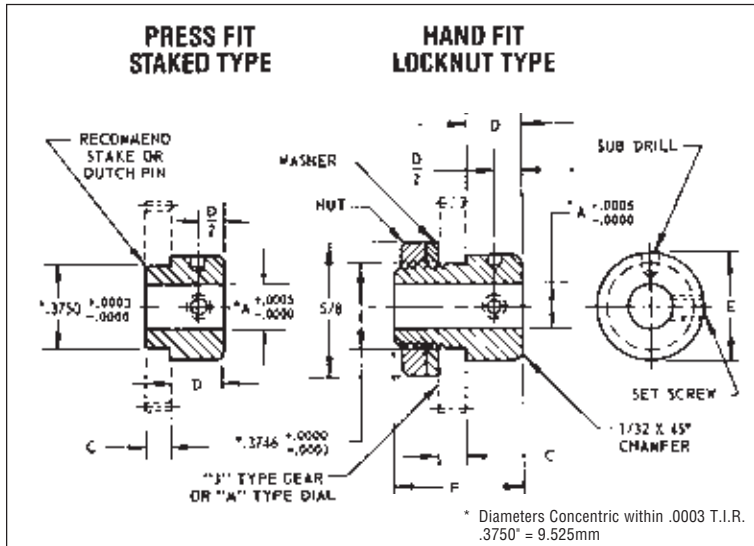

Material: 303 Stainless Steel

Hub Data					Sub Drill	Set Screw	Hand Fit Part No.	Press Fit Part No.
A	C	D	E	F				
.1200	.125	.22	7/16	—	#69	#2-56	—	K1-8
.1248	.062 .125	.22	7/16	.53 .60	#69	#2-56	K1-9 K1-10	K1-1 K1-2
.1873	.062 .125	.22	7/16	.53 .60	#60	#4-40	K1-11 K1-12	K1-3 K1-4
.2498	.062 .125	.25	1/2	.53 .60	#50	#6-32	K1-13 K1-14	K1-5 K1-6

Dimensions Are In Millimeters

Hub Data					Sub Drill	Set Screw	Hand Fit Part No.	Press Fit Part No.
A	C	D	E	F				
2.995	1.6	5.6	11.1	13.5	0.75	M2X0.4	MHU7-1	MHU6-1
2.995	3.2	5.6	11.1	15.2	0.75	M2X0.4	MHU7-2	MHU6-2
3.995	1.6	5.6	11.1	13.5	0.75	M2X0.4	MHU7-3	MHU6-3
3.995	3.2	5.6	11.1	15.2	0.75	M2X0.4	MHU7-4	MHU6-4
5.995	1.6	6.35	12.7	13.5	1.00	M3X0.5	MHU7-5	MHU6-5
5.995	3.2	6.35	12.7	15.2	1.00	M3X0.5	MHU7-6	MHU6-6

GEAR & DIAL HUB-SPLIT TYPE — 1/8", 3/16" and 1/4" = 3, 4 & 6mm Bores

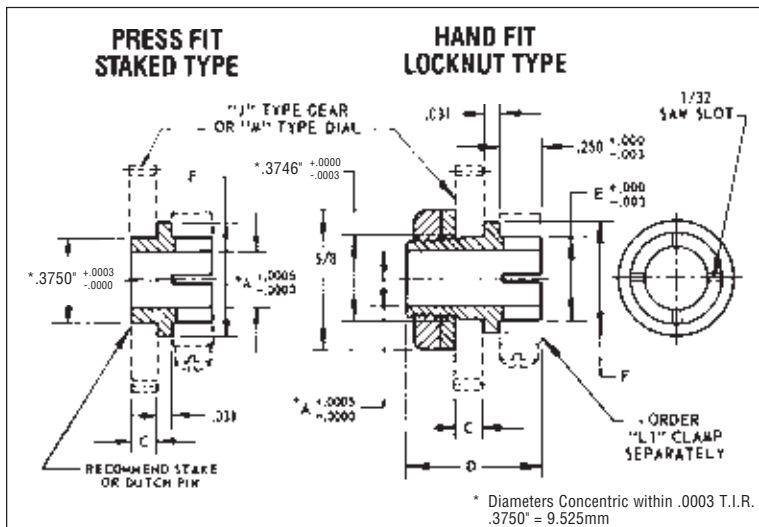

Material: 303 Stainless Steel

Hub Data					Hand Fit Part No.	Press Fit Part No.
A	C	D	E	F		
.1200	.125	.60	.188	7/16	—	K2-8
.1248	.062 .125	.53 .60	.188	7/16	K2-9 K2-10	K2-1 K2-2
.1873	.062 .125	.53 .60	.250	7/16	K2-11 K2-12	K2-3 K2-4
.2498	.062 .125	.53 .60	.312	1/2	K2-13 K2-14	K2-5 K2-6

Dimensions Below Are In Millimeters

Hub Data					Hand Fit Part No.	Press Fit Part No.
A	C	D	E	F		
2.995	1.6	13.5	4.78	11.1	MHU9-1	MHU8-1
2.995	3.2	15.2	4.78	11.1	MHU9-2	MHU8-2
3.995	1.6	13.5	6.35	11.1	MHU9-3	MHU8-3
3.995	3.2	15.2	6.35	11.1	MHU9-4	MHU8-4
5.995	1.6	13.5	7.92	12.7	MHU9-5	MHU8-5
5.995	3.2	15.2	7.92	12.7	MHU9-6	MHU8-6

GEAR HUBS — 5/16", 3/8" and 1/2" ■ 8, 10 & 12mm Bores

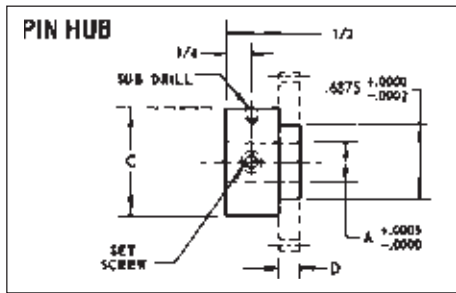

Material: 303 Stainless Steel

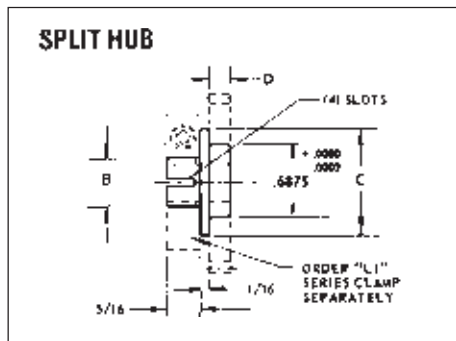

Shaft Size	Hub Data				Split Hub Part No.	Pin Hub	
	A	B	C	D		Set Screw	Part No.
5/16	.3123	.375	.875	3/16 1/8	K2-50 K2-50A	* 6-32	K1-50 K1-50A
3/8	.3748	.437	1.000	3/16 1/8	K2-51 K2-51A	* 8-32	K1-51 K1-51A
1/2	.4998	.562	1.250	3/16 1/8	K2-52 K2-52A	*10-32	K1-52 K1-52A

Dimensions Below Are In Millimeters

Shaft Size	Hub Data				Split Hub Part No.	Pin Hub	
	A	B	C	D		Set Screw	Part No.
8	7.995	9.52	22.22	4.76 3.18	MHU2-1 MHU2-2	M4X0.7	MHU1-1 MHU1-2
10	9.995	11.11	25.4	4.76 3.18	MHU3-3 MHU3-4	M5X0.8	MHU1-3 MHU1-4
12	11.995	14.29	31.75	4.76 3.18	MHU4-5 MHU4-6	M6X1	MHU1-5 MHU1-6

GEAR HUBS-CLUSTER — 1/8", 3/16" and 1/4" ■ 3, 4 & 6mm Bores

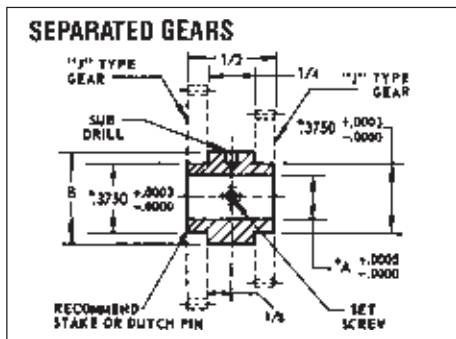

Material: 303 Stainless Steel

* Diameters Concentric within .0003 T.I.R.
.3750" = 9.525mm

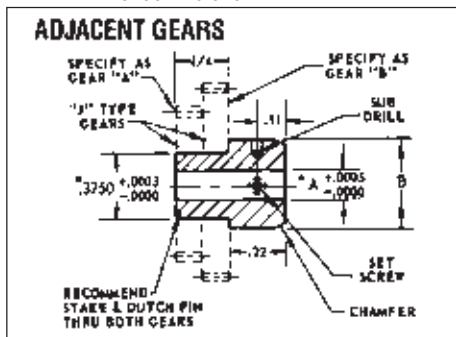

Shaft Size	Hub Data				Adjacent Part No.	Separated Part No.
	A	B	Sub Drill	Set Screw		
1/8	.1248	7/16	#69	#2-56	BH-7	BH-4
3/16	.1873	7/16	#60	#4-40	BH-8	BH-5
1/4	.2498	1/2	#50	#6-32	BH-9	BH-6

Dimensions Below Are In Millimeters

Shaft Size	Hub Data				Adjacent Part No.	Separated Part No.
	A	B	Sub Drill	Set Screw		
3	2.995	11.11	69	M2X0.4 6H	MHU5-4	MHU5-1
4	3.995	11.11	69	M2X0.4 6H	MHU5-5	MHU5-2
6	5.995	12.7	50	M3X0.5 6H	MHU5-6	MHU5-3

SECTION 1. Terms and Definitions

1.00 The following terms are basic and will be referred to in subsequent sections:

1.01 Gears are machine elements that transmit motion by means of successively engaging teeth (Figure 1.1).

1.02 A Gear is any machine part with gear teeth. Of two gears that run together, the one with the larger number of teeth is called the gear (Figure 1.1).

1.03 A Pinion is a gear with a small number of teeth. Of two gears that run together, the one with the smaller number of teeth is called the pinion (Figure 1.1).

1.04 A Rack is a gear with teeth spaced along a straight line and suitable for straight line motion (Figure 1.1).

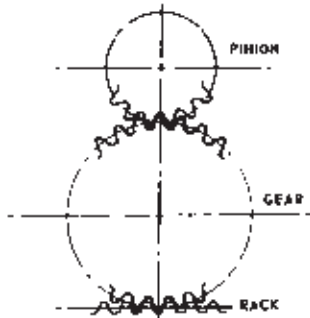

FIGURE 1.1 — GEARS

1.05 A Worm is a gear with one or more teeth in the form of screw threads (Figure 1.2).

1.06 A Wormgear is the mate to a worm. A wormgear that is completely conjugate to its worm has line contact and is said to be single enveloping. It is usually cut by a tool that is geometrically similar to the worm. An involute spur gear or helical gear used with a cylindrical worm has only point contact (Figure 1.2).

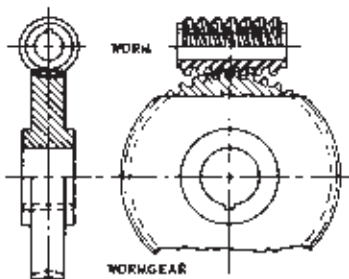

FIGURE 1.2 — WORMGEARING

1.07 A Helical Gear is cylindrical in form and has helical teeth (Figure 1.3).

1.08 Parallel Helical Gears operate on parallel axes and where both are external, the helices are of opposite hand (Figure 1.3).

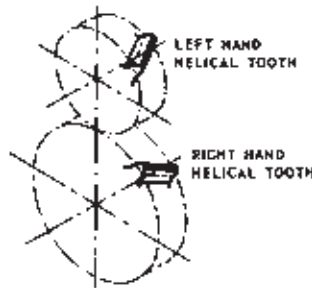

FIGURE 1.3 — PARALLEL HELICAL GEARS

1.09 Crossed Helical Gears operate on crossed axes and may have teeth of the same or opposite hand. The term Crossed Helical Gears has superseded the old term "Spur Gears" (Figure 1.4).

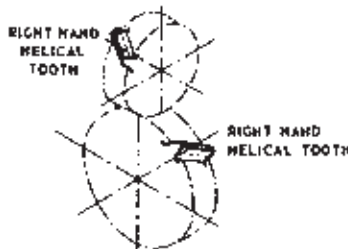

FIGURE 1.4 — CROSSED HELICAL GEARS

1.10 Bevel Gears are conical in form and operate on intersecting axes which are usually at right angles (Figure 1.5a).

1.11 Miter Gears are mating bevel gears with equal numbers of teeth and with axes at right angles (Figure 1.5b).

1.12 Straight Bevel Gears have straight tooth elements, which if extended, would pass through the point of intersection of the axes (Figure 1.5a).

1.13 Angular Bevel Gears are bevel gears in which the axes are not at right angles (Figure 1.5c).

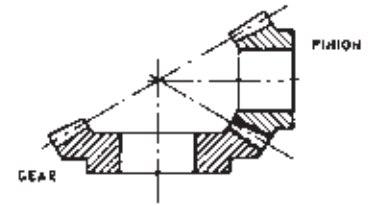

FIGURE 1.5a — BEVEL GEARS

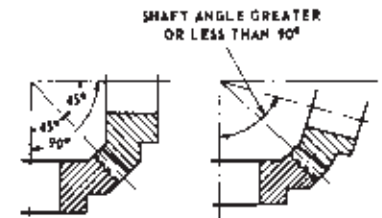

FIGURE 1.5b — MITER GEARS

FIGURE 1.5c — ANGULAR BEVEL GEARS

1.14 An Internal Gear is one with the teeth formed on the inner surface of a cylinder or cone. An internal gear can be meshed only with an external pinion (Figure 1.6).

1.15 An External Gear is one with the teeth formed on the outer surface of a cylinder or cone (Figure 1.6).



FIGURE 1.6 — INTERNAL & EXTERNAL GEARS

TECHNICAL SECTION

SECTION 1. Terms and Definitions

- 1.16 **The Axial Plane** of a pair of gears is the plane that contains the two axes. In a single gear, an axial plane may be any plane containing the axis and a given point (Figure 1.7).
- 1.17 **The Pitch Plane** of a pair of gears is the plane perpendicular to the axial plane and tangent to the pitch surfaces. A pitch plane in an individual gear may be any plane tangent to its pitch surface. The pitch plane of a rack or crown gear is the pitch surface (Figure 1.7).
- 1.18 **A Transverse Plane** is perpendicular to the axial plane and to the pitch plane. In gears with parallel axes, the transverse plane and plane of rotation coincide (Figure 1.7).
- 1.19 **A Plane of Rotation** is any plane perpendicular to a gear axis (Figure 1.7).

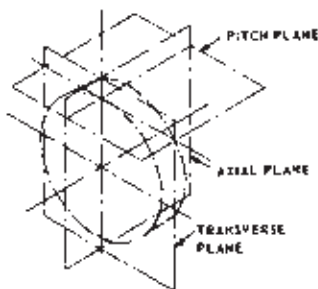

FIGURE 1.7 — PITCH, AXIAL & TRANSVERSE PLANES

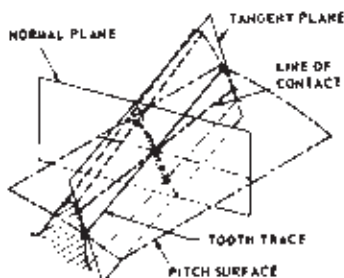

FIGURE 1.8 — NORMAL & TANGENT PLANES

- 1.20 **A Normal Plane** is in general normal to a tooth surface at a pitch point and perpendicular to the pitch plane (Figure 1.8).
- 1.21 **A Tangent Plane** is tangent to the tooth surfaces at a point or line of contact (Figure 1.8).

- 1.22 **Circular Pitch** is the distance along the pitch circle or pitch line between corresponding addendums of adjacent teeth (Figure 1.9).

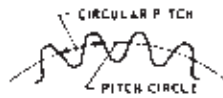

FIGURE 1.9 — CIRCULAR PITCH

- 1.23 **Normal Circular Pitch** is the circular pitch in the normal plane, and also the length of the arc along the normal helix between helical teeth or threads (Figure 1.10).
- 1.24 **Axial Pitch** is linear pitch in an axial plane and in a pitch surface. In helical gears and worms, axial pitch has the same value at all diameters. In gearing of other types, axial pitch may be confined to the pitch surface and may be a circular measurement (Figure 1.10). The term axial pitch is preferred to the term linear pitch. The axial pitch of a helical worm and the circular pitch of its wormgear are the same.
- 1.25 **Transverse Circular Pitch** is the circular pitch in the transverse plane (Figure 1.10).

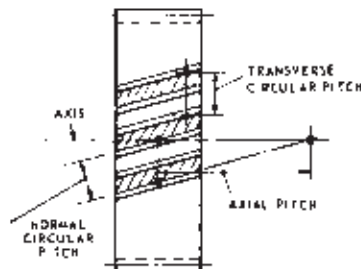

FIGURE 1.10 — NORMAL, TRANSVERSE & AXIAL PITCH

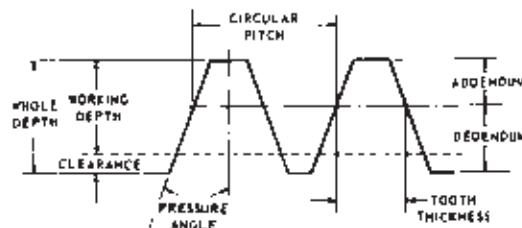

FIGURE 1.11 — BASIC RACK (NORMAL PLANE)

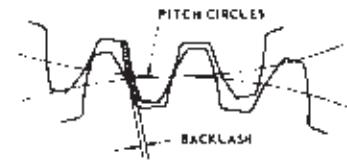

FIGURE 1.12 — BACKLASH

- 1.26 **Addendum** is the height by which a tooth projects beyond the pitch circle or pitch line, also, the radial distance between the pitch circle and the addendum circle (Figure 1.11).
- 1.27 **Dedendum** is the depth of a tooth space below the pitch circle or pitch line, also, the radial distance between the pitch circle and the root circle (Figure 1.11).
- 1.28 **Clearance** is the amount by which the dedendum in a given gear exceeds the addendum of its mating gear (Figure 1.11).
- 1.29 **Working Depth** is the depth of engagement of two gears that is the sum of their addendums (Figure 1.11).
- 1.30 **Whole Depth** is the total depth of a tooth space, equal to addendum plus dedendum, also equal to working depth plus clearance (Figure 1.11).
- 1.31 **Pitch Diameter** is the diameter of the pitch circle.
- 1.32 **Outside Diameter** is the diameter of the addendum tooth or profile.
- 1.33 **Backlash** is the amount by which the width of a tooth space exceeds the thickness of the engaging tooth on the operating pitch circles (Figure 1.12).

SPUR AND HELICAL GEARS

2.00 This section covers the recommended tooth proportions and design data for fine pitch spur and helical gears.

2.01 Basic Rack — The basic rack shown in Figure 2.1 is used to illustrate the tooth proportions covered by this standard. When small numbers of teeth, or special center distance situations are encountered, it is intended that long and short addendum proportions be used. This standard permits freedom of choice in making minor changes in the tooth proportions to meet special design conditions as long as the resulting gears are fully conjugate to the basic rack. Such changes may be indicated when a special contact ratio or top land is desired.

2.02 Spur Gears — The basic rack shown in Figure 2.1 and the tooth proportions shown in Table 2.1 provide the basic design data for spur gear teeth.

2.03 Helical Gears — The helical teeth covered by this standard are conjugated in the normal plane to the basic rack shown in Figure 2.1 and Table 2.1.

2.04 Standard Center Distance — Standard center distance is given by the equation shown in Table 2.1.

2.05 Center Distance Systems — There are two center distance systems in use. These are the Standard Center Distance System and the Enlarged Center Distance System. The choice of which is used will depend on the number of teeth in the meshing gears and on other design requirements. When an enlarged pinion is to be meshed with a gear at the center distance that is standard for the numbers of teeth, the gear diameter and tooth thickness must be decreased by the amount of the pinion enlargement. When two enlarged pinions or a 1 enlarged pinion and a standard diameter gear are meshed together, the center distance must be greater than standard.

2.06 Standard Center Distance System — (Long and short addendums.) In this system the center distance is made standard for the number of teeth, and the pressure angle remains constant. The outside diameter and root diameter of the gear is decreased the same amount; that the pinion diameter is increased.

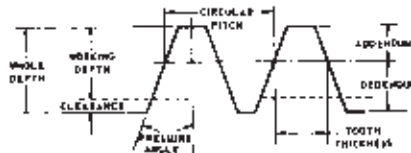

FIGURE 2.1 — BASIC RACK — (NORMAL PLANE)

2.07 Spur Pinion Enlargement — Enlargement of Spur Pinions of 20 Degree Pressure Angle and Diametral Pitches from 20 through 120. Spur pinions having fewer than the minimum numbers of teeth shown in Table 2.2 should be enlarged to avoid objectional undercut. Pinions of 20 degree pressure angle should be enlarged in accordance with the recommendations given in Table 2.3. The mating gear or the center distance should be adjusted as discussed in paragraph 2.06. Pinions of finer than 120 diametral pitch require special consideration since the proportionally larger clearance requires hobbs which tend to produce greater undercut. In general, pinions cut by the shaping process will not have as much undercut as those cut by hobbing.

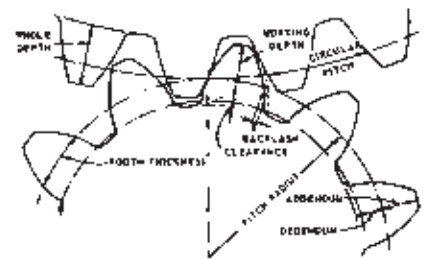

FIGURE 2.2 — SPUR, HELICAL, GEAR NOMENCLATURE

TABLE 2.1
TOOTH PROPORTIONS AND FORMULAS FOR
DIAMETERS AND STANDARD CENTER DISTANCE

(All values in millimeters)		
TOOTH PROPORTIONS		
Item	Spur	Helical
Addendum (a)	M	M _n
Dedendum (b)	M + c = 1.6M	M _n + c = 1.15M _n
Working Depth (h ₁)	2.000M	2.000M _n
Whole Depth (h ₂)	2.16M	2.16M _n
Clearance (c)	1M to 3M (1.66M typical)	1M to 3M _n (1.66M _n typical)
Tooth Thickness (t) at Pitch Diameter	$t = \frac{\pi M}{2}$	$t = \frac{\pi M_n}{2}$
FORMULAS		
Metric Module (M)	Dr _v	
Circular Pitch (p)	$p = \pi M$ or $\frac{\pi}{N}$	$p_n = \pi M_n$ or $\frac{\pi}{N}$
Pitch Diameter (D)	ψM	$\frac{N M_n}{\cos \psi}$
Outside Diameter (D _o)	$(N + 2)M$	$\left(\frac{N}{\cos \psi} + 2\right) M_n$
Center Distance (C)	$\frac{(N + n)M}{2}$	$\frac{(N + n)}{2 \cos \psi} M_n$

Where: M = Metric Module
M_n = Normal Metric Module
t = Normal Tooth Thickness at Pitch Diameter
p = Circular Pitch
p_n = Normal Circular Pitch
ψ = Helix Angle
N = Number of Gear Teeth
n = Number of Pinion Teeth
D = Pitch Diameter

(All values in inches)		
TOOTH PROPORTIONS		
Item	Spur	Helical
Addendum (a)	$\frac{1.000}{P}$	$\frac{1.000}{P_n}$
Dedendum (b)	$\frac{1.200}{P} + 0.002$ (min.)	$\frac{1.200}{P_n} + 0.002$ (min.)
Working Depth (h ₁)	$\frac{2.000}{P}$	$\frac{1.700}{P_n}$
Whole Depth (h ₂)	$\frac{2.200}{P} + 0.002$ (min.)	$\frac{2.200}{P_n} + 0.002$ (min.)
Clearance (c)	$\frac{0.200}{P} + 0.002$ (min.)	$\frac{0.200}{P_n} + 0.002$ (min.)
(Shaved or Ground Teeth)	$\frac{0.350}{P} + 0.002$ (min.)	$\frac{0.350}{P_n} + 0.002$ (min.)
Tooth Thickness (t) at Pitch Diameter	$t = \frac{1.5708}{P}$	$t = \frac{1.5708}{P_n}$
FORMULAS		
Circular Pitch (p)	$p = \frac{\pi}{N}$ or $\frac{d}{N}$	$P_n = \frac{\pi}{P_n}$
Pitch Diameter Pinion (d)	$\frac{n}{P}$	$\frac{n}{P_n \cos \psi}$
Pitch Diameter Gear (D)	$\frac{N}{P}$	$\frac{N}{P_n \cos \psi}$
Outside Diameter Pinion (d _o)	$\frac{n + 2}{P}$	$\frac{1}{P_n} \left(\frac{n}{\cos \psi} + 2 \right)$
Outside Diameter Gear (D _o)	$\frac{N + 2}{P}$	$\frac{1}{P_n} \left(\frac{N}{\cos \psi} + 2 \right)$
Center Distance (C)	$\frac{N + n}{2P}$	$\frac{N + n}{2P_n \cos \psi}$

Where: P = Transverse Diametral Pitch
P_n = Normal Diametral Pitch
t = Normal Tooth Thickness at Pitch Diameter
P_n = Normal Circular Pitch
ψ = Helix Angle
n = Number of Pinion Teeth
N = Number of Gear Teeth

TECHNICAL SECTION

SECTION 2. Basic Gear Formulas

SPUR AND HELICAL GEARS

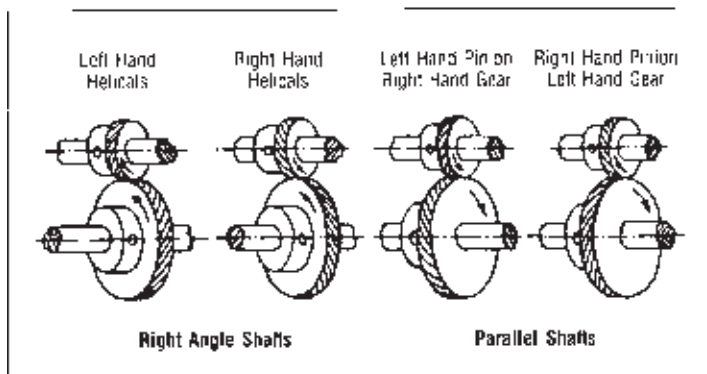

FIGURE 2.3 — HELICAL GEARS OF THE SAME HAND MESH AT RIGHT ANGLES
— HELICAL GEARS OF THE OPPOSITE HAND MESH ON PARALLEL SHAFTS

Any gear will mesh and run with any other gear of the same pitch. Recommend meshing stainless steel with aluminum gears for smoother running, longer life and silent operation. For best operation helical gears should run with thrust washers — see PIC standard stock thrust washers on page 6-11 and reference below.

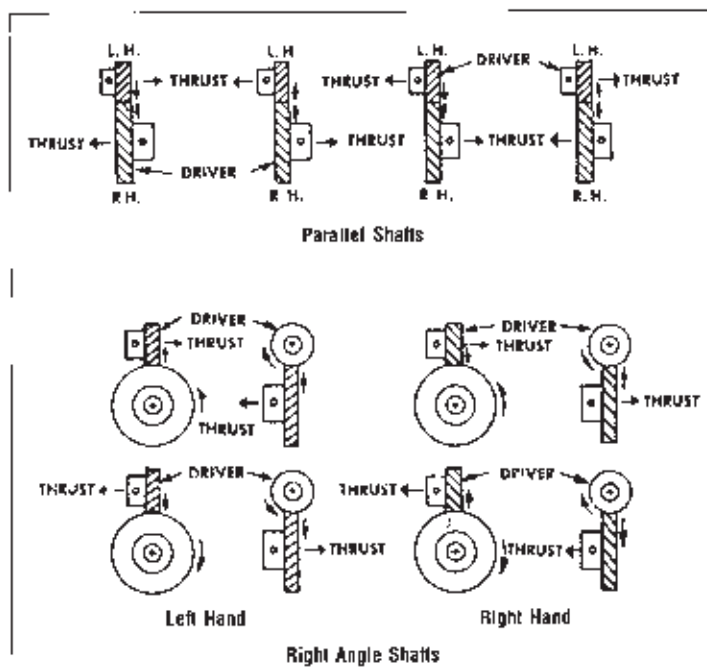

FIGURE 2.4 — THRUST LOADING DETAILS

TABLE 2.2
MINIMUM NUMBER OF PINION TEETH VS. PRESSURE ANGLE AND HELIX ANGLE
HAVING NO OBJECTIONABLE UNDERCUT

Helix Angle, Degrees	Minimum Number of Teeth to Avoid Undercut, Normal Pressure Angle, ϕ_n , degrees		
	14 1/2	20	25
0 (Spur Gears)	32	18	12
5	32	17	12
10	31	17	11
15	29	16	11
20	27	15	10
23	26	14	10
25	25	14	9
30	22	12	8
35	19	10	7
40	15	9	6
45	12	7	5

TABLE 2.3
20-DEGREE PRESSURE ANGLE INVOLUTE FINE-PITCH SYSTEM FOR MODIFIED
17 TEETH OR LESS SPUR PINIONS

(All tabular dimensions are given in inches for 1 diametral pitch. For other pitches divide tabular values by diametral pitch.)

Pinion Dimensions		Standard Center-Distance System (Long and Short Addendum) Gear Dimensions ¹				Enlarged Center-Distance System Standard Mating Gear Diameter ²		
Number of Teeth n	Outside Diameter	Cir. Tooth Thickness at Standard Pitch Diameter $\Delta t_p = \Delta d \tan \phi$	Decrease in Standard Outside Diameter	Cir. Tooth Thickness at Standard Pitch Diameter $\Delta t_p = \Delta d \tan \phi$	Recommended Minimum Number of Teeth (N)	Contact Ratio, n Mating With N ³	Increase Over Standard Center Distance	Contact Ratio Two Equal Pinions ³
10	12.8302	1.8736	0.8302	1.2686	33	1.419	0.4151	1.135
11	13.7132	1.8304	0.7132	1.2112	30	1.450	0.3556	1.186
12	14.5963	1.7878	0.5963	1.3536	27	1.473	0.2982	1.238
13	15.4793	1.7452	0.4793	1.3964	25	1.493	0.2397	1.290
14	16.3623	1.7027	0.3623	1.4389	23	1.508	0.1812	1.344
15	17.2453	1.6601	0.2453	1.4815	21	1.516	0.1227	1.398
16	18.1284	1.6175	0.1284	1.5241	19	1.519	0.0642	1.436
17	19.0114	1.5749	0.0114	1.5667	18	1.522	0.0057	1.511

The outside diameters of small pinions are enlarged to avoid undercut. Enlargements are based on addendum proportions of the basic rack. Figure 2.1, of $\frac{1.000}{P}$. When different proportions are used, the outside diameter must be adjusted accordingly.

- To maintain standard center distances when using enlarged pinions, the mating gear diameters must be decreased by the amount of the pinion enlargement.
- If mating gears are made with standard tooth proportions, the center distances must be increased as shown.
- Normal Values, will vary due to effects of tolerances.

STRAIGHT BEVEL GEARS

- 2.08** This section covers recommended proportions and dimensions of blanks for generated straight bevel gears of tooth ratios in general industrial use.
- 2.09 Bevel Gears** in this system have unequal addendums and unequal tooth thicknesses, except for pairs having equal numbers of teeth. This is different from the common practice for spur gearing. In bevel gear cutting, the tooth thickness is controlled by machine adjustments instead of by the tools, making it possible to obtain tooth thicknesses according to requirements for balance of strength in gear and pinion. Consideration has been given to both surface durability and beam strength in determining the tooth proportions.
- 2.10 An Advantage** in designing bevel gears according to this system is that tables are available giving tooth data and machine settings, thus minimizing calculations.* If other tooth designs are used, the data must be determined specially.
- 2.11 Angular Bevel Gears** are bevel gears whose shafts are set at an angle other than 90 degrees.
- 2.12 Backlash** — Table 2.4 gives the recommended backlash when the gear and pinion are finished and assembled ready to run. Quality numbers referred to in the Table are defined by the ASMA Gear Classification Manual, AGMA 390.02.

TABLE 2.4 RECOMMENDED BACKLASH

Diametral Pitch	Backlash	
	AGMA Quality Number	
	4 thru 6	7 thru 13
20 to 50	0.000 - 0.002	0.000 - 0.002
55 to 80	0.000 - 0.001	0.000 - 0.001
80 and finer	0.000 - 0.0007	0.000 - 0.0007

* These tables are available through Gleason Works, Rochester, New York.

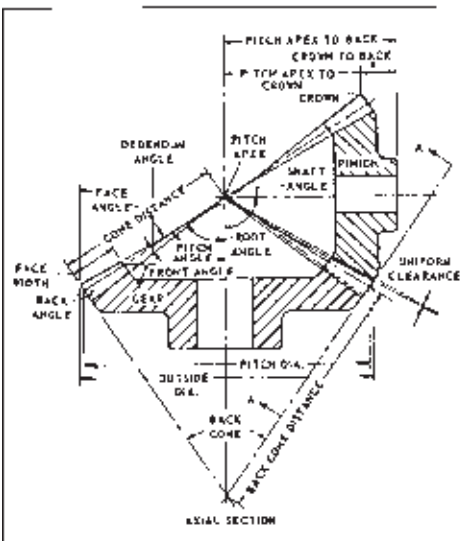

FIGURE 2.5 — BEVEL GEAR NOMENCLATURE

WORMGEARING

- 2.13 Wormgearing** is generally divided into two categories, fine-pitch worm gearing and coarse-pitch worm gearing. Fine-pitch worm gearing is segregated from coarse-pitch worm gearing for the following reasons:
- 2.14 Fine-Pitch Wormgears** are used largely to transmit motion rather than power. Tooth strength, except at the coarser end of the fine-pitch range, is seldom an important factor. Durability and accuracy, as they affect the transmission of uniform angular motion, are of greater importance. Housing constructions and lubricating methods are generally radically different in fine-pitch wormgearing.
- 2.15 Profile Deviations** and tooth bearings cannot be determined to the same degree of accuracy as those of coarse-pitch worms and wormgears, because of their small size.
- 2.16 Wormgear cutting equipment** generally available for fine-pitch gears has definite restrictions which limit the diameter and lead range, degree of accuracy and kind of tooth bearing obtainable.

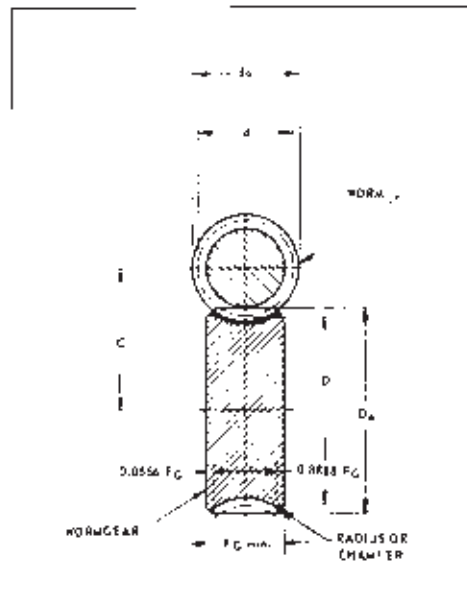

FIGURE 2.6 — WORM & WORMGEAR

- 2.17 Special Consideration** must be given to top lands in fine-pitch hardened worms and in gear cutting tools.
- 2.18 In Fine-Pitch Worms and Wormgears,** interchangeability and high production are important factors. Individual matching of the worm to the gear as is frequently practiced with coarse-pitch precision worms, is impractical in the case of worms of fine pitch.
- 2.19 The Methods** of production and inspection of fine-pitch wormgears are generally different from those of coarse pitch.
- 2.20 Proportions** of worms and wormgears are given in Table 2.5. The pitch relations are expressed by the following formulas:

TABLE 2.5 PROPORTIONS OF FINE PITCH WORMS AND WORMGEARS
Worm Dimensions

Term	Symbol	Formula (In.)
Lead	l	$1 P_1$
Pitch Diameter	d	$1 + (\pi \tan \lambda)$
Outside Diameter	d_o	$d + 2a$
Safe Minimum Length of Threaded Portion of Worm	l_w	$\sqrt{D_o^2 - D^2}$

* This formula gives a sufficient length for fine pitch worms.

Wormgear Dimensions

Pitch Diameter	D	$\lambda P_1 + \pi$
Outside Diameter	D_o	$2C + d + 2a$
Minimum Face Width of Wormgear	F_w	$1.25 \sqrt{(D_o + 2a)^2 - (d + 4a)^2}$

Data Relating to Worm and Wormgear

Addendum	a	$0.3183 P_1$
Whole Depth	h	$0.7003 P_1 + 0.002$
Working Depth	h_w	$0.6365 P_1$
Clearance	c	$h - h_w$
Tooth Thickness	t	$0.5 P_1$
Approximate Normal Pressure Angle	ψ	20 deg
Center Distance	C	$0.5 (d + D)$

Where p = Circular Pitch of Wormgear
 P_1 = Axial Pitch of Worm
 P_2 = Normal Circular Pitch of Worm and Wormgear
 $\lambda = P_2 \cos \lambda = p \cos \psi$
 λ = Lead Angle of Worm
 ψ = Helix Angle of Wormgear
 n = Number of Threads in Worm
 N = Number of Teeth in Wormgear

TECHNICAL SECTION

SECTION 3. Backlash Calculations

3.00 Backlash is the amount by which the width of a tooth space exceeds the thickness of the engaging tooth on the operating pitch circles. The following section contains a description of backlash sources and a method of calculating backlash in a gear train.

3.01 Sources of Backlash

For precision trains the backlash sources are many because of the significance of every contributor even if small. There are five major descriptive groupings.

3.02 Design Backlash Allowance

1. Gear size allowance — any specific reduction of gear size (tooth thickness or testing radius) below nominal value.
2. Center distance — any specific increase in center distance above nominal value.

3.03 Major Tolerance Backlash Sources

1. Gear size to tolerance (tooth thickness or testing radius).
2. Center distance tolerance.

3.04 Gear Center Shift Due to Secondary Sources

1. Fixed-bearing eccentricities
 - a. Outer-face eccentricity of ball bearings.
 - b. Sleeve bearings: inside-diameter and outside-diameter runout.
2. Radial clearances due to tolerances and allowances
 - a. Ball-bearing radial play.
 - b. Fit between shaft and bearing bore.
 - c. Fit between bearing outside diameter and housing bore.
3. Component error sources
 - a. Clearance between component-mounting pilot diameter and housing-mounting bore.
 - b. Component-mounting pilot eccentricity to shaft.
 - c. Component-mounting surface flatness and perpendicularity.
 - d. Component shaft radial play.

3.05 Backlash Sources Variable in Magnitude with Gear Rotation

1. Total composite error
 - a. Runout.
 - b. Tooth-to-tooth errors.
 - c. Lateral runout.
2. Clearance between gear bore and shaft.
3. Shaft runout at point of gear mounting:
 - a. Plain shafting.
 - b. Stepped stud or shaft.
4. Ball bearing rotating-face eccentricity.
5. Miscellaneous runouts
 - a. Component shaft.
 - b. Composite gear assembly.

3.06 Miscellaneous Sources:

1. Thermal dimensional changes.
2. Deflections: teeth, gear body, shaft, and housing.
3. Special environmental conditions — vibration, etc.

3.07 Example of Backlash Calculation

To illustrate procedures, an example of calculating gear-train backlash is given. Referring to Figure 3.1, backlash from the servomotor to the antenna azimuth shaft will be calculated. This illustrates a typical problem encountered in the design of small radar antenna drive gear trains in which backlash is important to a responsive and stable servo system. Additional design conditions not given in the figure and Table 3.1 are listed below (all dimensions in inches):

TABLE 3.1
DESIGN CONDITIONS FOR FIG. 3.1 GEAR TRAIN

Parameter	Mesh 1	Mesh 2	Mesh 3	Mesh 4
Gear size (testing radius)				
Allowance	0	0	.0005	.0005
Tolerance	+ .0003 - .0007	+ .0003 - .0012	+ .0006 - .0015	+ .0009 - .0015
Total composite error (max)	.0005	.001	.001	.001
Center distance				
Allowance	0	0	0	0
Tolerance	+ .001 - .000	+ .002 - .000	+ .002 - .000	+ .002 - .000

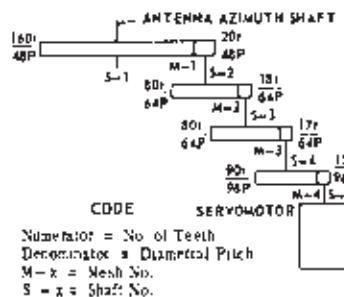

FIGURE 3.1 — GEARING SCHEMATIC AND DESIGN DETAILS FOR A SMALL RADAR ANTENNA DRIVE GEAR TRAIN

3.08 Entire TCE must be within Testing Radius Tolerance Bearings

All, except motor shafts, ABEC-5 ball bearings, 1/2 inch diameter. Radial clearance .0002 to .0005.

3.09 Housing Bore for Bearing Outside Diameter:

Allowance zero
tolerance + .0003
- .0000

3.10 Shaft Diameter:

Allowance .0001 from nominal diameter
tolerance + .0000
- .0002

3.11 Shaft Runout at Mounting of Gear .0002 max. TIR.

3.12 Gear Bore Diameter:

Nominal dimension + .0003
- .0000

3.13 Servomotor Details:

Pinion cut on shaft — testing radius reduced .0005 under runout, with — .0011 tolerance.
Shaft radial play .001 max.
Shaft runout .0008 max. TIR at mounting of gear.
Mounting diameter runout relative to shaft .001 TIR max.
Component-mounting design
Mounting pilot diameter tolerance: + .0000
- .0005
Mounting housing bore diameter tolerance: + .0005
- .0000
Allowance .0003

3.14 Pinion Design:

Mesh 1 — pinion to shaft

All other meshes — pinion is cut integral with shaft

3.15 All Gears 20° pressure angle

3.15 The Backlash contributors for each mesh are listed in Table 3.2. These are radial values (i.e., changes in center distance) and are converted to backlash by the factor $2 \tan \phi$, in this case .728. Thus, the angular values are

$$B_{\theta} = \frac{2 \tan \phi \Delta C}{R} \times \frac{180 \times 60}{\pi}$$

Mesh 1:

$$B_{\theta 1} = \frac{.728 (.0052)(34.38)}{1.6667} = .74 \text{ min of arc}$$

Mesh 2:

$$B_{\theta 2} = \frac{.728 (.0068)(34.38)}{6.250} = 27.1 \text{ min of arc}$$

Mesh 3:

$$B_{\theta 3} = \frac{.728 (.0084)(34.38)}{6.250} = 33.5 \text{ min of arc}$$

Mesh 4:

$$B_{\theta 4} = \frac{.728 (.0085)(34.38)}{4.688} = 46 \text{ min of arc}$$

Summing the mesh totals, with proper velocity ratio factors relative to reference shaft S-1, the gear train maximum backlashes

$$\left[\text{Backlash from S-1 to S-5 measured at S-1} \right] =$$

$$B_{\theta} = B_{\theta 1} + \frac{B_{\theta 2}}{v_2} + \frac{B_{\theta 3}}{v_3} + \frac{B_{\theta 4}}{v_4}$$

$$B_{\theta} = .74 + \frac{27.1}{8} + \frac{33.5}{35.6} + \frac{46}{16}$$

$$= 12.4 \text{ min of arc}$$

Note that 63 percent of the train backlash is in the first mesh because of the high velocity ratios of subsequent meshes. Calculation of the third mesh contribution is of questionable significance, and the fourth mesh is unnecessary.

The backlash value calculated is a maximum which will never be exceeded if parts are made according to design specification; it can be approached only if all backlash design tolerances are at their maximum values.

TECHNICAL SECTION

SECTION 3. Backlash Calculations

**TABLE 3.2
BACKLASH EXAMPLE CALCULATION**

Backlash Source	Design Data: Shaft No. → Pitch Dia. →	Maximum Backlash (Radial Value)							
		Mesh 1		Mesh 2		Mesh 3		Mesh 4	
		Gear	Pinion	Gear	Pinion	Gear	Pinion	Gear	Component Pinion
		S-1 3.333	S-2 .4157	S-2 1.250	S-3 .2812	S-3 1.250	S-4 .2656	S-4 .9375	S-5 .1562
Group I. Design Backlash Allowance									
* 1. Center distance allowance		0	—	0	—	0	—	0	—
2. Gear size allowance		0	0	0	0	.0005	.0005	.0005	.0005
Group II. Major Tolerances									
* 1. Center distance		.001	—	.002	—	.002	—	.002	—
2. Gear size		.0007	.0007	.0012	.0012	.0015	.0015	.0015	.0011
Group III. Secondary Sources									
1. Fixed-bearing eccentricities:									
a. Ball-bearing fixed race		.0001	.0001	.0001	.0001	.0001	.0001	.0001	
b. Sleeve-bearing runout									
2. Radial clearances:									
a. Ball-bearing radial play		.0003	.0003	.0003	.0003	.0003	.0003	.0003	
b. Clearance: Shaft and bearing bore:									
(1) Shaft diameter tolerance		.0001	.0001	.0001	.0001	.0001	.0001	.0001	
(2) Bearing bore tolerance		.0001	.0001	.0001	.0001	.0001	.0001	.0001	
(3) Allowance		.00005	.00005	.00005	.00005	.00005	.00005	.00005	
c. Clearance: Bearing OD and housing bore:									
(1) Bearing OD tolerance		.0001	.0001	.0001	.0001	.0001	.0001	.0001	
(2) Housing bore diameter tolerance		.00015	.00015	.00015	.00015	.00015	.00015	.00015	
(3) Allowance		0	0	0	0	0	0	0	
3. Component error sources:									
a. Clearance: component mounting:									
(1) Component-mounting pilot dia. tolerance									.00025
(2) Housing-mounting bore dia. tolerance									.00025
(3) Allowance									.00015
b. Component's mounting pilot eccentricity									.0005
c. Component mounting pilot flatness and perpendicularity									.0005
c. Component shaft radial play									
Group IV. Sources Variable with Rotation (one-half total value)									
1. Total composite error:									
a. Runout									
b. Tooth to tooth composite									
2. Clearance: Gear mounting to shaft:									
a. Gear bore diameter tolerance		.00015	.00015	.00015		.00015		.00015	
b. Shaft diameter tolerance		.0001	.0001	.0001		.0001		.0001	
c. Allowance		.00005	.00005	.00005		.00005		.00005	
3. Shaft runout at gear mounting		.0001	.0001	.0001		.0001		.0001	
4. Ball-bearing rotating-race eccentricity		.0001	.0001	.0001	.0001	.0001	.0001	.0001	
5. Miscellaneous runouts:									
a. Component shaft									
b. Composite gear assembly									
6. Other sources									
Group V. Miscellaneous Sources									
1. Thermal									
2. Deflections									
3. Other sources									
Sub-Total		.0031	.0021	.0046	.0022	.0054	.0030	.0054	.00325
Mesh Total		.0052		.0068		.0084		.00665	

* These are values for a pair and are arbitrarily put into gear columns.

TECHNICAL SECTION

SECTION 4. Gear Strength Calculations

4.00 In Fine-Pitch Gearing Applications, gear teeth are sometimes subject to high static loads. An example would be when a mechanism is driven into a mechanical stop. It is extremely important that the gears be capable of withstanding this maximum static torque. The following section contains a method by which static strength of gears can be calculated, in addition to a graphical representation of the strengths of different sizes of gears.

4.01 The Lewis Formula is used for determining the force which may safely be applied to spur gear teeth. This formula considers the gear as a cantilever beam with the full load applied to one tooth. It should be remembered that more than one tooth is actually in contact during engagement and therefore the load is partially shared with another pair of teeth. The amount of this load distribution is dependent upon the contact ratio of the particular gears in mesh. Typical values are from 1.2 to 1.8.

4.02 The Curves (Figure 4.1) are based on the Lewis Formula (using 303 Stainless Steel, $S = 30,000$ psi)

$$L = \frac{SFY}{P} \text{ where}$$

- L = Maximum safe tangential load at pitch diameter, lbs
- S = Allowable static unit stress for material, psi
- Y = Allowable unit stress for material at gear velocity

$$\left(S - S_0 \times \frac{600}{600 + V} \right) \text{ psi}$$

- V = Velocity, FPM at pitch diameter
- F = Face width of gear, in
- Y = Bending factor (machinery handbook, 16th ed., p.717)
- P = Diametral pitch

The curves represent static gear tooth strength, therefore

$$V = 0 \text{ and } S = S_0$$

Method 1. Using Lewis Formula

$$\text{Static torque capacity } T_s = \frac{L \times PD}{2} \text{ in. oz.}$$

$$PD = \frac{\text{No. Teeth}}{Pitch} = \frac{50}{48} = 1.0417 \text{ in.}$$

$$S = 40,000 \text{ psi (See Table 4.1)}$$

$$F = .87 \text{ in.}$$

$$v = .438$$

$$P = 48$$

$$L = \frac{SFY}{P} = \frac{(40,000) (.87) (1.408) (.16)}{48}$$

$$L = 1017.28 \text{ ounces}$$

$$T_s = \frac{(1017.28 \times 1.0417)}{2} = 529.85 \text{ in. oz.}$$

Method 2. Using Torque Curves

Start at 50 Teeth on our Graph

Go to 48 Pitch Curve

Read torque 132 in. oz. for 1/16" Face Width

Multiply by 3 for 3/16" Face Width = 396 in. oz.

Since the curves are based on 303 Stainless Steel with a yield strength of 30,000 psi, torque must be multiplied by strength factor 1.33 to determine capacity of 2024-T4 Aluminum Gear (40,000 psi)

$$T_s = 396 \times 1.33 = 528 \text{ in. oz.}$$

EXAMP. E Determine the Static Torque Capacity of a 48 Pitch, 50 Tooth, 2024-T4 Aluminum Gear (Face width 3/16 inch)

TABLE 4.1
YIELD STRENGTH FOR VARIOUS MATERIALS

Material	Yield Strength, PSI*	Strength Factor
416 Stainless Steel (Annealed)	40,000	1.33
415 Stainless Steel (RC22)	95,000	3.16
416 Stainless Steel (RC37)	134,000	4.46
303 Stainless Steel	30,000	1.00
17-4PH Stainless Steel (Cond. H900)	173,000	5.66
2024-T4 Aluminum Alloy	40,000	1.33
Bronze	26,000	.86
Phenolic	8,000	.27
Nylon, Delrin	6,000	.20

* Data approximate, subject to variations among suppliers

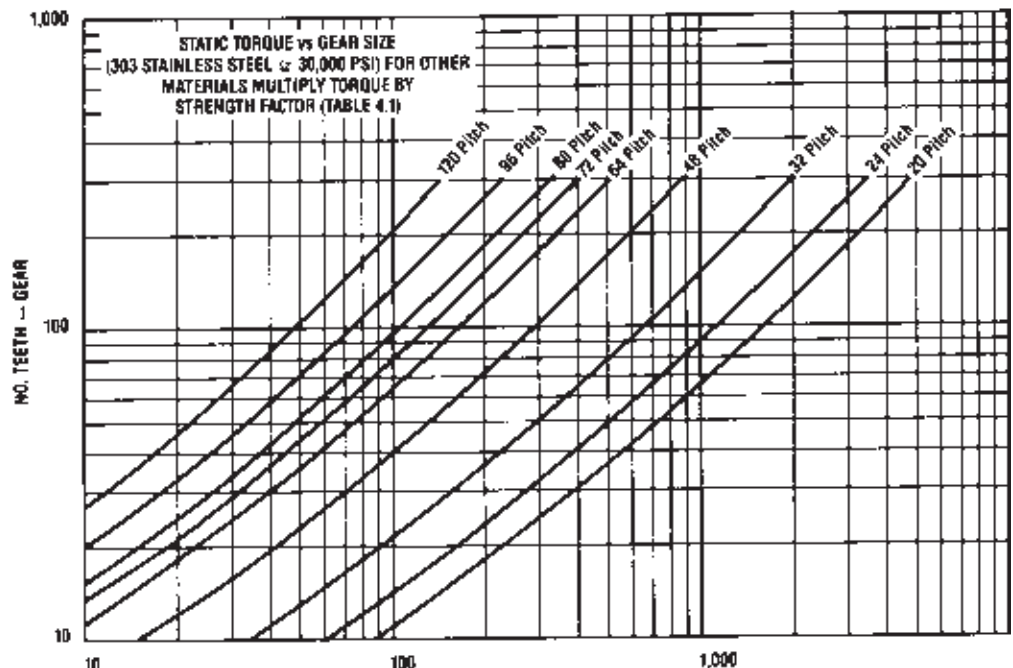

FIGURE 4.1 — STATIC TORQUE IN. OZ. (PER 1/16" FACE WIDTH GEAR)

COMPOSITE ERROR CHECK

5.00 PIC Gears are inspected on variable center distance equipment where they are meshed with a master gear under light checking pressure (tabulated below). As the gears rotate, center distance changes are greatly amplified and recorded on PIC "TRUE BLUE" Gear Tapes as shown in Figure 5.1.

5.01 Refer to Gear Tolerance Tables 5.2 and 5.3 for detailed gear tolerances. The value "True Blue" Tapes are available with PIC spur and bevel gears for a nominal additional charge based on the quantity involved.

GEAR TESTING RADIUS

5.02 Gear Size is controlled by specifying a maximum and a minimum gear testing radius. The inspection trace must lie between these limits. The maximum limit for PIC stock gears is set at the theoretical pitch radius. The minimum limit is determined by the class of gear being cut.

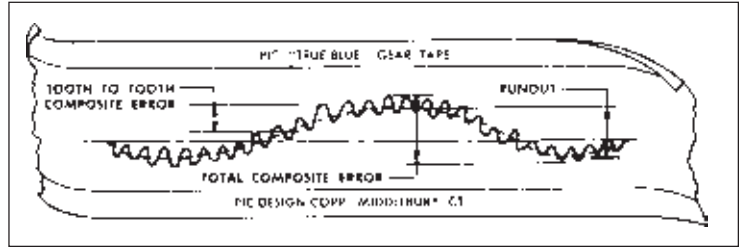

FIGURE 5.1 — "TRUE BLUE" GEAR TAPE

TABLE 5.1
AGMA 390.03 FINE-PITCH GEAR TOLERANCES TABLE

AGMA Quality No.	No. of Teeth and Pitch Diameter	Diametral Pitch Range	Tooth-to-Tooth Composite Tolerance	Total Composite Tolerance
10*	Up to 20 Teeth Incl	20 to 200	0007	0010
	Over 20 Teeth	20 to 200	0005	0010
	Up to 1.999"			
	Over 20 Teeth	20 to 200	0005	0012
2" to 3.999"				
11	Over 20 Teeth	20 to 200	0005	0014
	4" and over			
	Up to 20 Teeth Incl	20 to 200	0006	0007
	Over 20 Teeth			
Up to 1.999"	20 to 200	0004	0007	
Over 20 Teeth				
12**	Over 20 Teeth	20 to 200	0003	0006
	2" to 3.999"			
	Over 20 Teeth	20 to 200	0003	0007
	4" and over			
13	Up to 20 Teeth Incl	20 to 200	0003	0004
	Over 20 Teeth			
	Up to 1.999"	20 to 200	0002	0004
	Over 20 Teeth			
14***	Over 20 Teeth	20 to 200	0002	0004
	2" to 3.999"			
	Over 20 Teeth	20 to 200	0002	0005
	4" and over			
15	Up to 20 Teeth Incl	20 to 200	00014	00027
	Over 20 Teeth			
	Up to 1.999"	20 to 200	00010	00019
	Over 20 Teeth			
2" to 3.999"	20 to 200	00010	00023	
				Over 20 Teeth
4" and over	20 to 200	00010	00027	

TABLE 5.2
GEAR TOLERANCES

AGMA Class Gear	P.D. Tol.	O.D. Tol.	Bore Tol.	C.D. Fixed Centers	C.D. Adjustable Centers
D 10	- .001	- .002	+ .0005	+ .0005	+ .002
D 12	- .0007	- .0015	+ .0003	+ .0003	+ .0015
D 14	.0005	- .001	+ .0002	+ .0002	+ .0012

TABLE 5.3
AGMA 2015-2-A06 FINE-PITCH GEAR TOLERANCES TABLE

PIC Quality Number	DIN Δ Quality Number	Pitch Diameter	Metric Module Range	Tooth-to-Tooth Composite Tolerance μm	Total Composite Tolerance μm
T7	C7 / T7	Up to 12mm	Up to 0.6 Module	7	20
		Over 12 to 50mm		9	25
		Over 50 to 100mm		10	28
		Over 100mm		11	32
T6	C6 / T6	Up to 12mm	Up to 0.6 Module	8	22
		Over 12 to 50mm		10	28
		Over 50 to 100mm		11	32
		Over 100mm		12	36
T5	C5 / T5	Up to 12mm	Up to 0.6 Module	5	14
		Over 12 to 50mm		5.5	16
		Over 50 to 100mm		6	18
		Over 100mm		7	20
T5	C5 / T5	Up to 12mm	Up to 0.6 Module	5.5	16
		Over 12 to 50mm		6	18
		Over 50 to 100mm		7	20
		Over 100mm		8	22
T5	C5 / T5	Up to 12mm	Up to 0.6 Module	3.5	10
		Over 12 to 50mm		4	11
		Over 50 to 100mm		4.5	12
		Over 100mm		5	14
T5	C5 / T5	Up to 12mm	Up to 0.6 Module	3.5	11
		Over 12 to 50mm		4.5	12
		Over 50 to 100mm		5	14
		Over 100mm		5	16

Δ DIN, ISO, ANSI
All Dimensions in millimeters

Extracted from AGMA Gear Classification Manual for Spur, Helical and Herringbone Gears (AGMA 390.03), with the permission of the publisher, The American Gear Manufacturers Association, 1330 Massachusetts Avenue, N.W., Washington, D.C. 20005.

* AGMA 390.03/PIC Q10 = AGMA/ANSI 2015-2-A06 C7/ISO T7

** AGMA 390.03/PIC Q12 = AGMA/ANSI 2015-2-A06 C6/ISO T6

*** AGMA 390.03/PIC Q14 = AGMA/ANSI 2015-2-A06 C5/ISO T5

TECHNICAL SECTION

SECTION 5. Military Specifications — Shaft and Bearing Fits

**TABLE 6.1
MILITARY CROSS REFERENCES**

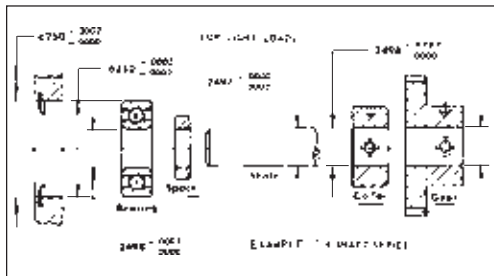

Materials			Finishes		Used On
PIC Catalog Designation	UNS Designation	Mil. or Fed. Specification	PIC Catalog Designation	Mil. or Fed. Specification	PIC Products
#303 Stainless Steel (Bar)	S30300	ASTM-A-582	**	**	Gears ⁽²⁾ , Shafts, Couplings
#303 Stainless Steel (Sheet)	S30300	ASTM-A-666	**	**	Gears ⁽²⁾
#303 Stainless Steel (Spring Temper)	S30200	ASTM-A-666	**	**	Springs, Washers
#416 Stainless Steel	S41600	ASTM-A-582	**	**	Racks, Gears, Shafts
#440 Stainless Steel	S44004	QQ-S-763 Class 10 Type A	**	**	Ball Bearings
#420 Stainless Steel	S42000	QQ-S-763	**	**	Retainer Rings
2024-T4/T351 Alum (Bar)	A92024	QQ-A-225/6	Anodized	MIL-A-8625	Gears ⁽²⁾ , Spacer Posts
2024-T3 Alum (Sheet)	A92024	QQ-A-250/4	Anodized	MIL-A-8625	Gears ⁽²⁾
2024-T4/T351 Alum (Bar)	A92024	QQ-A-225/6	Black Anodized	MIL-A-8625	Dials, Drum
2024-T3 Alum (Sheet)	A92024	QQ-A-250/4	Black Anodized	MIL-A-8625	Dials, Disc
#108 Cast Aluminum	—	ASTM-B26	Anodized	MIL-A-8625	Hangers, Breadboards
Bronze (Tobin)	C46400	ASTM-B-21 Alloy 464	—	—	Worm Wheels
Oil-Less Bronze	—	MIL-B-438 Type II Grade 1	Lubricated with SAE 30 Oil	—	Bearings Thrust Washers
Brass (Laminated)	—	MIL-S-22499 Comp. 2 Class 1	—	—	Shims
Beryllium Copper	—	QQ-C-533	Anodized	MIL-A-8625	Retainer Rings
Neoprene (Molded)	—	MIL-R-6855 Class II	—	—	Flex. Couplings Pulley Belts
Grease	—	MIL-G-23827	—	—	Gears, Bearings -65°F to +250°F
Oil	—	MIL-G-6085	—	—	Gears, Bearings -65°F to +250°F
A2 Stainless Steel (Type #304)	S30400	DIN 267 (QQ-S-763)	**	**	Fasteners
A4 Stainless Steel (Type #316)	S31600	DIN 267 (QQ-S-763)	**	**	Fasteners

STANDARD TOLERANCES

Inch

Unless otherwise specified, tolerances are as follows:

Two (2) place decimals $\pm .016$

Three (3) place decimals $\pm .005$

Fractional $\pm 1/32$

Angles $\pm 1^\circ$

Metric

(All dimensions in millimeters)

Unless otherwise specified, tolerances are as follows:

One (1) place decimals ± 0.8

Two (2) place decimals ± 0.13

Angles $\pm 1^\circ$

NOTES:

1. Brief description of the UNIFIED NUMBERING SYSTEM

The unified numbering system (UNS) provides a means of correlating many nationally used numbering systems currently administered by societies, trade associations, and individual users and producers of metal and alloys, thereby avoiding confusion caused by use of more than one identification number for the same material – and by the opposite situation of having the same number assigned to two or more entirely different materials

2. Refer to 12-4 for gear material specifications by product series.

**Clear passivate finish to military or federal specifications. Available upon request.

TECHNICAL SECTION

SECTION 7. Equivalent

TABLE 7.1
TABLE OF EQUIVALENT DIAMETER MODULE AND CIRCULAR PITCHES

Diametral Pitch	Circular Pitch (inches)	Circular Pitch (millimeters)	Module (millimeters)
20*	0.1571	3.990	1.2700
24*	0.1309	3.325	1.0583
25.4000	0.1237	3.142	1.0*
31.4159	0.1000*	2.540	0.8085
31.7500	0.0989	2.513	0.8*
32*	0.0982	2.494	0.7938
36.2857	0.0866	2.199	0.7*
42.3333	0.0742	1.885	0.6*
48*	0.0654	1.662	0.5292
50.8000	0.0618	1.571	0.5*
63.5000	0.0495	1.257	0.4*
64*	0.0491	1.247	0.3969
72*	0.0436	1.108	0.3528
80*	0.0393	0.997	0.3175
84.6667	0.0371	0.942	0.3*
96*	0.0327	0.831	0.2646
101.6000	0.0309	0.785	0.25*
120*	0.0262	0.665	0.2117
127.0000	0.0247	0.628	0.2*
200*	0.0157	0.399	0.1270

*Standard pitches and modules offered by PIC Design.

TABLE 7.2
SPUR GEAR DATA

Standard Stock Pitches	Addendum	Odendum	Whole Depth	Circular Pitch
20	0500	0579	1079	1571
24	.0417	0520	0937	1309
1/10	0318	0402	0720	1000
32	0313	0395	0708	0982
48	0208	0270	0478	0654
64	0156	0208	0364	0491
72	0139	0187	0326	0436
80	0125	0170	0295	0393
96	0104	0145	0249	0327
120	0083	0120	0203	0262
200	0050	0080	0136	0157

TABLE 7.3
SPUR GEAR DATA FOR STANDARD MODULES
(All dimensions in millimeters)

Standard Module M	Addendum M	Odendum* 1.16M	Whole Depth 2.16M	Circular Pitch πM
0.2	0.200	0.234	0.434	0.628
0.25	0.250	0.292	0.541	0.785
0.3	0.300	0.350	0.654	0.943
0.4	0.400	0.467	0.866	1.256
0.5	0.500	0.584	1.085	1.571
0.6	0.600	0.701	1.300	1.885
0.7	0.700	0.818	1.519	2.199
0.8	0.800	0.935	1.735	2.513
1.0	1.000	1.166	2.167	3.142

* Based on clearance equaling one-sixth module

NOTE:

To determine theoretical center distance of gears, add the total number of teeth in both gears, then determine the pitch diameter and divide by two.

EXAMPLE:

Using a 99 and 18 tooth gears, using 24 D.P. gears = $99 + 18 = 117$
 P.D. = teeth/pitch = $117/24 = 4.875$
 Theoretical Center Distance is $4.875 / 2 = 2.4378$.
 To allow for any variations add 0.001"

Set up P.D. = theoretical plus 0.001" = 2.4388"

$$DP = \frac{25.4}{\text{Module}} \quad \text{Module} = \frac{25.4}{\text{D.P.}}$$

ALPHABETICAL INDEX

PRODUCT	DESCRIPTION	CATALOG SERIES	SECTION-PAGE	PRODUCT	DESCRIPTION	CATALOG SERIES	SECTION-PAGE		
ACME Lead Screws	Adjustable Compliant Nut	ANR3	3-12	Blanks	Gear-Pin Hub	BP, BQ	12-53		
	Anti-Backlash Nuts	ANR2	3-11		Hubless	BU	12-53		
	Bearing Housing	S10, MS10, S12	3-14		Bore Reducers	Inch to Inch	R	7-14	
	Flanges	FL, LMB	3-13			Inch to Metric	MR	7-14	
	Power Nuts	ANR1	3-10		Brakes	Flange Mounted-Power On Brakes	RX1 to RX4	7-3	
	Screws	AR	3-9			Flange Mounted-Power Off Brakes	RY5 to RY8	7-3	
	Shim Pack	SP	3-4		Breadboard	Development Parts	BB	8-25	
	Balls	Precision, Hardened (Metric)	MBL1			6-18	Cams	Follower	P1
		Stainless Steel, Nylon (Inch)	AK, AL		6-18	Chain	.250 Pitch	EL25	5-41
	Ball Slides	Economy	PBE		2-5		Miniature Pitch-.1475 CP	EL	5-41
Positioners with Micrometers		P	2-12	Clamps	Hub-Split	L1-20 to -22	6-19		
Positioning Stage (Table)		PBC	1-12		-Split	L4-1 to -3	6-19		
Precision		PBO4 to PB3	2-4		-Screw	L4-13 to -15	6-19		
Recirculating Slide Guide	SEB	2-10	-Adjustable		L1-1 to -9	6-20			
Bearings (Inch)	Ball, Non-Corrosive	EG	6-10	Cleats	Synchro Mounting	L2	8-12		
	Ball, Precision, Flanged	E2,E4,E6 to E12	6-4,6-5		Adjustable-Miniature	L5 & L6	6-20		
	Ball, Precision,	E1,E3,E6 to E19	6-4,6-5	Clutches	Instant Nulling	L3	8-12		
	Bronze, Precision, Oil	AM	6-11		Motor Mount	L2	8-12		
	Impregnated Bronze, Oil Impregnated	B10	6-6	Collars	Synchro Mounting Clamps	L2	8-13		
	Extended Inner Ring	E1 to E4	6-3		Continuous Slip - Adjustable	T25	7-5		
	Extra Thin Ball	E5	6-3		Continuous Slip (Inch)	T17	7-4		
	Housing Block	S10,S12,MS10	3-14		Roller Clutches	EC	7-7		
	Housing Blocks	AA,AP,R1-R6	6-14,6-15	Components	Shaft Mounted Clutches	RW1 to RW4	7-4		
	Mounting Plate	AP	6-14		Slip Assembly	R3	7-6		
	Rod Ends	PE3 to PE16	6-12		Slip, Continuous Operation	MCH2	7-4		
	Sleeve & Flanged Non-Metallic	BS,BF	6-8		Slip, Intermittent Operation (Metric)	MCH3, 4	7-6		
	Sleeve-Bronze, Oil Impregnated	B10, B11	6-6	Couplings (Inch)	Set Screw-Precision (Inch)	C1-1 to -11	6-18		
	Sleeve-Teflon	B14, B15	6-10		Set Screw, Precision (Metric)	MSC1	6-18		
	Spherical	PE12	6-13		Bearing Mounting Plate	AP3	6-14		
	Tapered O.D.	E8	6-3		Breadboard Development Parts	BB	8-25		
	Bearings (Metric)	Thrust	ET	6-11	Breadboard-Kits	G, N, R	10-3		
Ball, Non-Corrosive		MEG	6-10	Chassis Handles	EF	8-20, 8-21			
Ball, Precision (Extra small series)		MBG1 to 4	6-5	Component Mounting Hangers	S1, S3	6-26			
Ball, Precision (Standard series)		MBG5 to 8	6-5	Bellows	T1	7-9			
Bronze, Oil-Impregnated		MBG9, 10	6-7	Bellows-Zero Adjustable	T9, T10	7-9			
Bearings (Linear)	Sleeve & Flanged Non-Metallic	MBS, MBF	6-9	Flexible-"K" Type	T21,T24	7-14			
	Ball, Recirculating	PL, PA	4-9	Flexible - Neoprene Center	T11, T12	7-10			
	Ball, Recirculating, Flanged	PL & MPL	4-7	Flexible-Zero Backlash	T22	7-13			
	Ball, Recirculating, Instrument	PLS	4-8	Multi-Jaw	N4, N5	7-11			
	Ball, Recirculating, Metric	MPL	4-9	Oldham-Miniature	T7, T8	7-11			
	Ball, Recirculating, Self-Aligning	PFL & MPFL	4-10	Shaft Extension	AU	6-21			
	Engineered Plastic	PL & MPL	4-11	Sleeve-Precision	D-1	7-12			
	Housings	S5,S8,MSC, MSA, MSO	4-13 & 4-14	Slip-Continuous Duty	T18	7-5			
	Belt	Ceramic Coated	BLC, BLO, MBL	4-12	Slip-Intermittent Duty	T14	7-6		
		Round	AF2-AF6	5-38 to 5-40	Spider	T13	7-7		
"No Slide"				Universal Joint-Stainless	BC-1	7-15			
40 DP		F8B	5-20	Universal Joint-Molded	BC-21	7-15			
1/5 Pitch		F20B	5-21	Universal Lateral	T16	7-10			
3/8 Pitch		F37B	5-22	Wafer Spring	T15	7-8			
Ferrules		FER	5-5	Bellows	MCU1, MCU2	7-9			
Splice Kit		F8,F20,F37	5-5	Bellows-Zero Adjustable	MCU3, MCU4	7-9			
"No Slip"				Flexible-Neoprene Center	MCU7, MCU8	7-10			
.1475 CP, Twin Core		FRA, FRS	5-12	Flexible-Zero Backlash	MT22	7-13			
20DP, Single & Triple Core		FLA, FLS	5-14	Multi-Jaw	MCU13, MCU14	7-11			
20DP, Twin Core		FMA, FMS	5-16	Oldham, Miniature	MCU9, MCU10	7-11			
24DP, Twin Core		F24CS	5-10	Sleeve, Precision	MCU5, MCU6, MCU20	7-12			
25CP, Twin Core		F25CS	5-18	Couplings (Metric)	Slip, Adjustable, Intermittent	MCU18, MCU19	7-6		
32DP, Single Core		FA, FS	5-6		Slip, Continuous	MCU17	7-5		
32DP, Twin Core		F32CS	5-8		Universal-Lateral	MUJ1	7-10		
32DP, Single Core (light)		F32BS	5-6		Universal Joint-Stainless	MUJ3, MUJ4	7-15		
Splice Kit	F_-SK	5-5	Universal Joint-Molded	MUJ2	7-15				
Tensioner	TE	5-3	Wafer Spring	MCU15	7-8				
Timing E*P*S			Hand, with Nameplate	W3	8-25				
-.080 Pitch	EPS-A	5-26	Cross Rollers	Aluminum, Steel	PNBT	2-6, 2-7			
-.0816 Pitch	EPS-C	5-28		Rails	PNB	2-9			
-1/5 Pitch	EPS-D	5-30		Economy	PRB	2-8			
-3/8 Pitch	EPS-J	5-33							
HTD*-3mm Pitch	EPS-F	5-34							
HTD*-5mm Pitch	EPS-G	5-36							

ALPHABETICAL INDEX

PRODUCT	DESCRIPTION	CATALOG SERIES	SECTION-PAGE	PRODUCT	DESCRIPTION	CATALOG SERIES	SECTION-PAGE
Dials	Disc-Precision Engraved	M1	8-22	Hub Clamps	For Split Hub Gears		
	Disc and Vernier Sets	AW	8-22		-Split Type	L1-20 to L1-22	6-19
	Drum-Precision Engraved	M2	8-23		-Screw Type	L4-1 to L4-3	6-19
	Drum and Vernier Sets	AX	8-23		-Adjustable	L4-13 to L4-15	6-19
Drive Belts (see Belts)	Locks & Indexes	M1,M4,M5	8-24	-Balanced	L1-1 to L1-6	6-20	
	Synchronous, Timing	Section 5		-Miniature,Standard	L1-7 to L1-9	6-20	
Extrusions	Accessories	SCA,SCE	9-9,9-10	-Miniature,Reduced Clearance	L5-1 to L5-5	6-20	
	Aluminum Framing Elements	SX	9-3	-Gear-Cluster	L6-1 to L6-5	6-20	
Gears (Inch)	Brackets	SCX,SCB	9-5,9-6	-Split Hub	BH-4 to BH-6	12-68	
	Hardware	SCH	9-6,9-7,9-8	Gear & Dial-Pin Type	K2-50 to K2-52A	12-68	
	Mounting Components	SCB,SCX	9-5,9-6	Gear & Dial-Split Type	K1-1 to K1-6	12-67	
	Anti-Backlash-Spur 24DP to 96DP	P2-1 to P70-4	12-36 to 12-44	Gear	K2-1 to K2-6	12-67	
	Bevel-48DP, 64DP, 72DP	N1-1 to N3-5	12-50, 12-51	Gear & Dial,Pin Type	MHU1 to MHU5	12-68	
	Bevel-Anti-Backlash-48DP, 64DP, 72DP	N1-1-AB	12-51	Geneva Mechanism	MHU6, MHU7	12-67	
	Blanks-Pin Hub, Hubless	N3-1-AB-S	12-51	Geneva Mechanism	MHU8, MHU9	12-67	
	Cluster-48DP & 64DP	BP to BU	12-53	Assembly	EU-1 to EU-4	11-7, 11-8	
	Helical-48DP & 64DP	CO, CN	12-35	Keys	EV	11-6	
		AC1 to AC8	12-45	Keys & Sets-Socket Head	CS-40 to CS-50	10-3	
		AD1 to AD8	12-45	Woodruff	CR	8-24	
		K1,K2,MHU	12-67,12-68	Breadboard	G,N,R	10-3	
	Hubs Inch & Metric	—	12-4	Educational	KE-121 to KE-150	10-1,10-2	
	Index-Spur Gear			Knurled Precision	BG-1 to BG-9	8-25	
	Miter & Bevel	N1-1 to N3-5	12-50, 12-51	Lead Screws	ARS	3-9	
	Non-Metallic-Delrin, Nylon,	AB13 to AB24	12-31 to 12-34	PS Style	PS	3-5	
	Pinion Shafts-24DP to 200DP	F4 to F9	12-28	Anti-backlash, Power	PZ,PK,PV,ANR	3-6 to 3-12	
	Racks-24DP to 120DP	AG-1 to AG-160	12-29,12-30	*SEE Bearings, Linear	BL,C,BL0,PL,PA	4-7 to 4-12	
	Spiral-Pin Hub, Hubless	EK1 to EK14	12-52		PO,PFL		
	Spiral Pinions	EJ1-A to EJ3-B	12-52	Linear Motion	Design Guide	LM	1-1
Spur Anti-Backlash	P2-1 to P70-4	12-36 to 12-44	Systems Assemblies	LS	1-5 to 1-11		
Spur-Hubless, 24DP to 120DP	J1 to J28	12-7 to 12-27	Ball Slide	PB	2-4		
Spur-Pin Hub, 20DP to 120DP	G1 to G83	12-6 to 12-27	Ball Slide Guide	SEB	2-10		
Spur-Pin Hub, 16DP	16T	12-5	Positioners with Micrometers	P101 to P2201	2-12		
Spur-Pin Hub, 24DP	24T	12-8	Rails	PNB1 to PNB6	2-9		
Spur-Pin Hub, 32DP	32T to 32HT	12-10 to 12-13	Aluminum Crossed Roller Slides	PNBT	2-6		
Spur-Split Hub, 24DP to 96DP	H1 to H60	12-7 to 12-27	Steel Crossed Roller Slides	PNBT	2-7		
Worm Wheel-Anti-Backlash, 48DP & 64DP	Q13 to Q20	12-49	Crossed Roller Slides - Economy	PRB	2-8		
Worms & Worm Wheels-48DP to 64DP	Q1 to Q12	12-46,12-48	Dial	M1	8-24		
Gears (Metric)	Spur, Hubless	MHS1 to MHS12	12-54 to 12-66	Flange Mounted-Power On Brakes	RX1 to RX4	7-3	
	Spur, Pin Hub	MSG3 to MSG34	12-54 to 12-66	Flange Mounted-Power Off Brakes	RY5 to RY8	7-3	
	Spur, Split Hub	MSG35 to MSG50	12-54 to 12-66	Shaft Mounted Clutches	RW1 to RW4	7-4	
Gear Assemblies	Bevel Gear-48DP	BA-11 to BA-13	11-5	Magnetic Door Latch Assembly	SCA	9-11	
	Gear Heads-Size 11 & 18	U7, U8	11-3				
	Helical Gear-48DP	DU-4 to DU-6	11-5	Mounting Accessories	Linear Bearing Housings	S5,S8,MSA, MSC & MSO	4-13 & 4-14
	Miter Gear-48DP	BA-3	11-5	Shaft Support Rails & Predrilled	PSR & MP SR	4-4 & 4-5	
Geneva Mechanism	Servo Gear Boxes-Ratios from 2:1 to 625:1	ES-1 to ES-41	11-4	Shaft Support Rails & Assemblies	A10-X-SR, A11-X-SR, A12-X-SR	4-4 & 4-5	
	Speed Reducers-Size 10,11 & 18	U1 to U4	11-1 & 11-2	Thumb, Knurled	4070 to 4094	8-17	
	Worm & Wheel-48DP & 64DP	DJ, DQ	11-4	Swivel, Knurled	3140 to 3145	8-18	
	Servo Gear Boxes (Metric)	MGB3	11-6	Thumb, Knurled	MTN1	8-18	
	Intermittent Motion	EU-1 to EU-4	11-7,11-8	Accessories	SCA,SCE	9-9 to 9-11	
	Intermittent Motion Ass'y	EV	11-6	Aluminum Framing Elements	SX	9-3, 9-4	
Hand Crank Handles	Crank	W3	8-25	Brackets	SCX,SCB	9-5 to 9-7	
	Chassis-Stainless Steel & Aluminum	EF	8-20,8-21	Hardware	SCH	9-7 to 9-9	
Hangers	Framing-Plastic, Aluminum	SCA	9-11	Mounting Components	SCB,SCX	9-5,9-6	
	Shaft	S7,SHA & MSHA	4-6	Spur Gears-24DP to 200DP	F4 to F9	12-28	
	Universal (Bearing Block)	R1,R2	6-15	Dowel-Stainless(Slip Fit)	D2 to D14	8-14	
	Double (Bearing Block)	R5,R6	6-15	-Hardened (Press Fit)	D15 to D22	8-16	
	Bearing Housings	AA1 to AA6	6-14	-Carbon Steel	D25 to D32	8-16	
Hinges	Bearing Housings	S10,S12 & MS10	3-14	-Stainless (Interference Fit)	D40 to D50	8-14	
	Framing-Plastic, Aluminum	SCA7	9-11	Dowel,Precision-Press Fit	MDP1 to MDP11	8-15	
				Dowel,Hardened-Press Fit	MDP13 to MDP20	8-15	

ALPHABETICAL INDEX

PRODUCT	DESCRIPTION	CATALOG SERIES	SECTION-PAGE	PRODUCT	DESCRIPTION	CATALOG SERIES	SECTION-PAGE
Plates	Bearing Mounting	AP-3	6-14	Rod	Threaded, Stainless	A9	6-21
Positioners	With Micrometers	P101 to P2201	2-12	Rod Ends	Nylon or Bronze Race	PE	6-12
Positioning Stage	Ball Slide Table	PBC	1-12	Rollers Rubber	Drive	RD	4-15
Posts	Spacer, Square Stock	F1,F2,F3	8-13	Covered	Idlers	RS	4-15
Pulleys	Threaded, Round Stock	EG1 to EG15	8-13	Screws (Inch)	Captive	Y9	8-9
	"No Slip"				Screws-Set-Brass Tip	CS	8-7
	32DP-Machined (Inch)	FC,FD,F32	5-7 & 5-9		Screws-Set-"No Mar"	CS-1 to CS-36	8-6
	32DP-Machined (Metric)	MGP1 to MGP4 & MF32	5-7 & 5-9		Screws-Set-"Silver Grip"	CS-51 to CS-67	8-5
	20DP-Single Core	FLG,FLH	5-15		Screws-Set-Cup Point	BE, Y11, C2-15	8-7
	20DP-Twin Core (Inch)	FMG,FMH	5-17		Shoulder-Slotted Head (303)	4310 to 4365	8-2
	20DP-Twin Core (Metric)	MFMG	5-17		Shoulder, Phillips Head (303)	4710 to 4754	8-4
	.1475CP (Inch)	FRG,FRH	5-13		Shoulder-Socket Head (303)	4410 to 4465	8-3
	.1475CP (Metric)	MFRG	5-13		Shoulder, Slotted Head (416)	4510 to 4565	8-2
	Grooved	AE	5-38 to 5-40		Shoulder, Socket Head (416)	4610 to 4665	8-3
	.25CP (inch)	F25	5-19	Screws (Metric)	Shoulder, Phillips Head (416)	4810 to 4854	8-4
	.25CP (metric)	MF25	5-19		Thumb, Knurled	4010 to 4058	8-17
	.24DP (inch & metric)	F24G & MF24	5-11		Captive-Slotted Head-Cup Point	MCS1	8-9
	"No Slide"				Set, "No-Mar", Hexagon Type	MSS2	8-6
	40DP (Inch & Metric)	F8P & MF8P	5-20		Set, "Silver-Grip" Hexagon Type	MSS3	8-5
	1/5 Pitch (Inch & Metric)	F20P & MF20P	5-21	Shaft	Set, Socket, Hexagon Type	MSS4	8-7
	3/8 Pitch (Inch & Metric)	F37P & MF37P	5-22		Shoulder, Phillips Head	MSB7 & MSB8	8-4
	Timing Belt E*P*S*				Shoulder, Slotted Head	MSB1 & MSB3	8-2
	-.080 Pitch	PT-A	5-26,5-27		Shoulder, Socket Head	MSB2 & MSB4	8-3
	-.0816 Pitch	PT-C	5-28,5-29		Shoulder, Phillips Head	MSB7 & MSB8	8-4
	-1/5 Pitch	PT-D	5-30 to 5-32		Thumb, Knurled	MTS1	8-18
	-3/8 Pitch	PT-J	5-33		Collars-Precision, Set Screw	C1-1 TO C1-11	6-18
	-3mm Pitch-HTD	PT-F	5-34,5-35		Extensions	AU	6-21
	-5mm Pitch-HTD	PT-G	5-36,5-37		Hangers-Double	R5, R6	6-15
R&D Parts	Component Mounting Data	S1	6-26		-Standard	S7	4-6
	Component Mounting Hangers	S1,S3,S4	6-26		-Universal	R1, R2	6-15
	Handles, Chassis	EF	8-20,8-21		Shaft Support Blocks, Hangers	SHA & MSHA	4-6
	Mounting Plate-Bearing	AP-3	6-14		Shaft Support Rails & Assemblies	A10-X-SR, A11-X-SR, A12-X-SR	4-5
	Nuts-Knurled Swivel	3140 to 3145	8-18		Shaft Support Rails & Predrilled	PSR & MPSR	4-4 & 4-5
	-Thumb, Knurled (Inch)	4070 to 4094	8-17	Shafting (Inch)	303 Ground Stainless Steel & Predrilled	A11	4-3,4-4 & 6-25
	-Thumb, Knurled (Metric)	MTN1	8-18		440 Hardened & Ground Stainless & Predrilled	A12	4-3,4-4 & 6-25
	Screws-Thumb, Knurled (Inch)	4010 to 4058	8-17		Ground-Precision 1/32" to 1"Dia	A8	6-22
	-Thumb, Knurled (Metric)	MTS1	8-18		-Precision 1/8"	A1	6-23
	Studs-Double Threaded	2040 to 2065	6-21		-Precision 3/16"	A2	6-23
	-Swivel	2100 to 2106	8-18		-Precision 1/4"	A3	6-23
	Washers-Precision	3150 to 3156	8-9		-Precision 3/8"	A7	6-23
	Washers-Swivel	3160 to 3176	8-18		-Ultra Precision 1/8"	A4	6-22
Racks	Data-Fine Pitch Racks	—	12-29		-Ultra Precision 3/16"	A5	6-22
	Fine Pitch-24 to 120 Pitch	AG	12-29,12-30		-Ultra Precision 1/4"	A6	6-22
	Rectangular-24 To 120 Pitch	AG-10 to AG-16	12-30		Hardened & Ground Steel	A10-A10L	4-3,4-4 & 6-25
	Round	AG-17 to AG-23	12-30		Predrilled	ACS - A12	4-8
Rails	Crossed Roller	PNB,PNBT,PRB	2-6 to 2-9		Instrument Series	AU	6-21
Reducers	Bevel Gear Box-1/4 Shaft	BA-11 to BA-13	11-5		Shaft Extension	—	6-23
	Bore	R & MR	7-14		Standard Shaft Modifications	MA11	4-3,4-4 & 6-25
	Gear Head-Size 11	U7	11-3	Shafting (Metric)	303 Ground Stainless Steel & Predrilled	MA12	4-3,4-4 & 6-25
	-Size 18	U8	11-3		440C Hardened & Ground	MA10	4-3,4-4 & 6-25
	Helical Gear Assembly	DU	11-5		Stainless & Predrilled		
	Miter Gear Box-1/4 Shaft	BA-3	11-5		Hardened & Ground Steel & Predrilled		
	Precision-Size 10	U1	11-1		Precision,Ground,Long Lengths	MSH7	6-24
	-Size 11	U2, U3	11-2		Precision,Ground,Precut	MSH1 to MSH4	6-24
	-Size 18	U4	11-2	Shims	Inner Race-.002" to .500"	B4, B6, B8, B12, B14, B15	6-17
	Servo Gear Box-1/4 Shaft(Inch)	ES	11-4		Laminated Brass	B1, B2	6-18
	Servo Gear Box (Metric)	MGB	11-6		Outer Race-.003" to .500"	B3	6-16
	Worm & Worm Assembly-1/4 Shaft	DJ & DQ	11-4				
Retaining Rings (Inch)	E-Ring, Plain & Bowed	Z3, Z4	8-10				
	External Gripping	Z5	8-11				
	Internal & External	Z1, Z2	8-10				
Retaining Rings (Metric)	Internal & External	MRR1 & MRR2	8-11				
	Plain	MRR3	8-11				

ALPHABETICAL INDEX

PRODUCT	DESCRIPTION	CATALOG SERIES	SECTION-PAGE	PRODUCT	DESCRIPTION	CATALOG SERIES	SECTION-PAGE
Shims (Metric)	Inner Race	MSP1 to MSP4	6-17	Thumb Nut	Knurled-Inch	4070 to 4094	8-17
	Outer Race	MSP6	6-16		Knurled-Metric	MTN1	8-18
Slides	Aluminum Crossed Roller Slides	PNBT-A	2-6	Thumb Screw	Knurled-Inch	4010 to 4058	8-17
	Ball Slide	PB04 to PB3	2-4		Knurled-Metric	MTS1	8-18
	Crossed Roller Slides	PRB	2-8	Timing Belts	E*P*S Synchronous-.080 Pitch	EPS-A	5-26
	Economy Ball Slide	PBE	2-5	(also see Belts)	-.0816 Pitch	EPS-C	5-28
	Positioners with Micrometers	P101 to P2201	2-12		-1/5 Pitch	EPS-D	5-30
	Rails	PNB1 to PNB6	2-9		-3/8 Pitch	EPS-J	5-33
	Recirculating Ball Slide Guide	SEB	2-10		-HTD -3mm Pitch	EPS-F	5-34
	Steel Crossed Roller Slides	PNBT	2-7		-HTD -5mm Pitch	EPS-G	5-36
Speed Reducers	Bevel Gear Boxes	BA-11 to BA-13	11-5	Universal Joints	Molded	BC-21 to BC-35	7-15
	Gear Heads-Size 11	U7	11-3		Stainless-Pin Hub	BC-1 to BC-3	7-15
	Gear Heads-Size 18	U8	11-3	Verniers	For Disc & Drum Dials	AW	8-22
	Helical Gear Assembly	DU	11-5			AX	8-23
	Miter Gear Boxes-1:1 Ratio	BA-3	11-5	Washers (Inch)	Belleville Spring	D6-20 to D6-27	8-8
	Precision-Size 10	U1, MSR1	11-1		Curved	D33	8-9
	-Size 11	U2, U3, MSR2	11-2		Precision	3150 to 3156	8-9
	-Size 18	U4, MSR3	11-2		Swivel	3160 to 3176	8-18
	Servo Gear Boxes	ES-1 to ES-41, MGB3	11-4		Thrust	AH, AJ-1	6-11
			11-6		Wave Spring	D6-1 to D6-6	6-14
	Specification Data	—	11-1	Washers (Metric)	Belleville Spring	MBW1	8-8
	Worm & Wheel Assembly	DJ, DQ	11-4	Worms	48 Pitch	Q8,Q10,Q12	12-46
Springs	Anti-Backlash Gears	BE-16,-66,-67	8-19		64 Pitch	Q2,Q4,Q6	12-48
	Compression	AY-20 to AY-82	8-19	Worm Wheels	Anti-Backlash-Miniature		
	Experimental	AY-1 to AY-13	8-19		48 Pitch	Q15,Q17,Q19	12-47
	Extension	AZ-22 to AZ-58	8-19		64 Pitch	Q16,Q18,Q20	12-49
Sprockets	for "No Slip" Belts-20DP	FLG,FLH,FMG, FMH,MF	5-15,5-17		Anti-Backlash-Standard		
(also see Pulleys)	"No Slip" 32DP	FC,FD,F32,MGP	5-7, 5-9		48 Pitch	Q14	12-47
	.1475CP	FRG, FRH	5-13		64 Pitch	Q13	12-49
	for Miniature Pitch Chain-.1475CP & .250 Pitch (Inch)	EM	5-41 & 5-42		Right Hand		
	for Miniature Pitch Chain-.1475CP (Metric)	MMS1 to MMS4	5-42		Pin Hub-48 Pitch	Q7,Q9,Q11	12-46
	'No-Slip' 24DP	F24G & MF24G	5-11		-64 Pitch	Q1,Q3,Q5	12-48
	'No-Slip' .25CP	F25G & MF25G	5-19		Split Hub-48 Pitch	Q7,Q9,Q11	12-46
Stand-Offs	Precision Posts	F1 to F3	8-13		-64 Pitch	Q1,Q3,Q5	12-48
	Threaded Type	EG-1 to EG-15	8-13				
Studs	Double Threaded	2040 to 2065	6-21				
	Swivel	2100 to 2106	8-18				
Technical Data	Technical Section	—	13-1 to 13-11				
Threaded Stock	Stainless-#2-56 to 3/8-16	A9	6-21				
Thrust	Bearings	ET	6-11				
	Washers	AH & AJ	6-11				

The High Volume Source For Catalog and "Build-to-Print" Parts and Assemblies

PIC DESIGN... A Recognized World Leader

Pioneers of off-the-shelf standardization, PIC Design has been supplying customers with precision drive train components for over fifty years. PIC's catalog offers a complete selection of gears, sprockets, pulleys, shafts, pins, shoulder screws, and other drive components in prototype or small production quantities and has earned a solid reputation for prompt, reliable service and the highest quality standards.

A Supplier of Volume Precision Components and Subassemblies

PIC Design can answer the needs of cost-conscious buyers of volume precision drive train parts or sub-assemblies. PIC combines the exacting standards of short run, highly individual production with the economics that larger quantities and automated manufacturing processes now yield.

Additionally, PIC offers the experience and skill of its assemblers to produce sub-assemblies at a variety of levels.

If you work to the stringent specifications of the military or NASA, assemble products of various origins of manufacture, or want precision parts in quantity at affordable prices, you should seriously consider PIC.

Why PIC?

■ **Application Engineering.** Our engineers, if requested, will optimize your design to assure manufacturing feasibility. They'll also advise you on methods to simplify manufacturing and hold the line on costs.

■ **Specification.** Our extensive experience with defense contractors makes us completely familiar with military specifications and standards

■ **Advanced program management.** Using advanced computer technology, we track your order throughout the cycle, so that we know its status at any time. Then we schedule suppliers to meet the deadlines on your work. You get your delivery on time!

■ **Experience with most materials, including difficult and exotic materials.** Experience includes nickel, titanium, engineered plastics, etc.

■ **Sourcing.** We locate specialized vendors and material for you

■ **Manufacturing.** Using our state-of-the-art volume production techniques, we can supply you fast turn-around on large-volume quantities.

■ **Testing.** We have a wide array of sophisticated testing equipment, capable of meeting the tightest specifications and standards.

■ **Quality assurance and inspection.** From incoming inspection, through work in progress, to the final stage, your work is rigorously examined as part of our quality assurance and inspection program.

■ **Packaging.** We know how to help you minimize handling and maximize product protection. We'll custom-pack your order so that it's ready for use from robotics to storage

■ **Traceability.** PIC's extensive and highly detailed record keeping guarantees our ability to quickly determine the supplier of any material or service we use in the production of individual parts or of sub-assemblies.

■ **Quality and precision.** By combining the practices and procedures that have served us for thirty years with the significant production capabilities of modern technologies and equipment, PIC can deliver the best of both concepts

Here's a sampling of what we can do for you.



Processes

Primary Machining

CNC Milling and turning, conventional and Swiss screw machining

Secondary Machining

Honing, Precision grinding: double disc, centerless, surface and cylindrical. Precision milling, turning, boring, reaming, drilling and tapping. Gear capability: CNC & conventional hobbing, shaping and bevel generating.

Precision Assembly

Mechanical and electromechanical requiring exacting fitting and adjustment from very small watch movement sizes on up.



Materials

Steels

Low, medium carbon and alloy.

Stainless Steels

300 and 400 series and precipitation hardening.

Aluminum

2024, 6061, 7075 in T4 and T6 condition.

Brass, Copper, Bronze, Phosphor and Aluminum Bronze

Nickel silver, Waspaloy, Kovar and Nitralloy

Exotic and Specialty Alloys

Can be quoted on request

Plastics

Filled and non-filled including delrin, nylon, polyurethane, polycarbonate, phenolic, Vespel and Teflon.



Finishes/Treatments

Passivating, Anodizing (chromic & sulphuric)

Plating

Chromium, hard chromium, cadmium, nickel (including electroless), Zinc, Gold, Silver

Alodine, Irilac

Heat Treating

Conventional and nitriding

Post Finish Treatments Including Dry Lube



Sizes

PIC Design

Works up to the following diameters on a wide variety of products.

Turning

Up to 16" diameter

Milling

Up to 16" X 50"

Shoulder Screws

3/4 in. (20 mm).

Pins and Shafts

2 in (50 mm)

Coupling Collars/Spacers

4 in (100mm)

Gears

From 8 to 200 Diametral Pitch (from 0.20 to 2.5 module). From 1/8 in. to 151/2 in. Outside Diameters (3.0 mm to 400.0 mm)

Worms and Wheels

48 and 64 Diametral Pitch

Racks

From 8 to 120 Diametral Pitch (from .2 to 2.5 module). Lengths up to 48 in. (1220 mm).



Tolerances

Machining

To 0.0001 in (0.0025 mm)

Surface finishes

To 4 microinch (0.10 micrometer).

Straightness

To 0.0001 in. per in. (0.001 mm /cm).



Quality

Standards

Besides our own rigid standards, PIC Design regularly works to MIL-I-45208A and to the ISO 9001:2000 Standard.

Calibration.

To MIL-STD-45662 and ISO 10012 Standards including full documentation and tractability

Gears and Racks

Up to AGMA Quality Q14 (in.) And up to DIN standard class T5 (metric).

Special requirements.

PIC Design's familiarity with various Federal, ANSI, MIL and AS9102 First Article Inspection Standards and industry specifications allows us to certify conformance to your particular requirements.

E-MAIL, MAIL OR FAX US YOUR BUILD-TO-PRINT REQUIREMENTS TODAY!



For fifty years PIC Design has been the gold standard for manufacturers of precision industrial components. Our quality service and integrity are appreciated by our vast number of repeat customers and envied by our competitors. If you are new to PIC Design, we look forward to working with you on your next requirement as well as through the next 50 years.



PIC Design is located in the Naugatuck Valley of Connecticut – famous as the precision machining center of the country. Our size allows us to respond quickly with the solution to most any problem. Our location provides a wealth of backup skills and services unique to this area. As the pioneer and leader in the field of precision industrial component catalog sales, PIC has always maintained a very high standard of quality and service commanding good will, respect and loyalty of over 20,000 active customers.

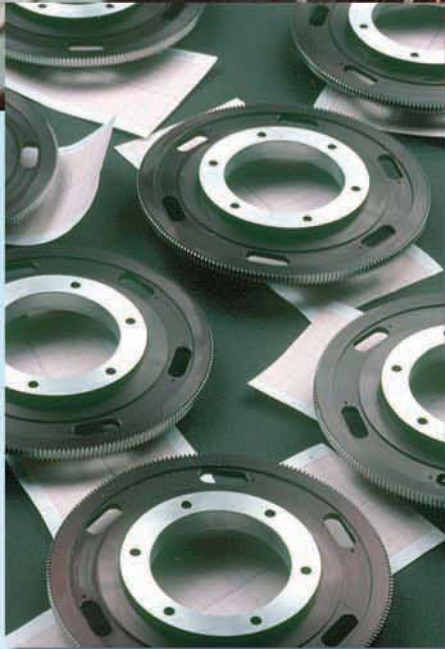
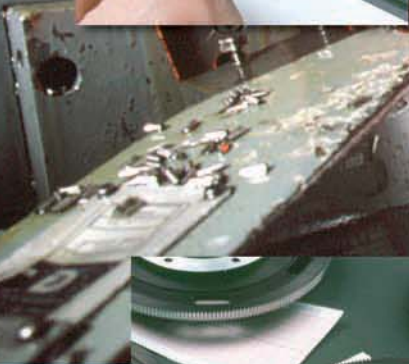

Let's discuss your volume parts or sub-assembly requirements.

Call PIC's headquarters between 8 A.M. and 5 P.M. Eastern Time.

Phone: 800-243-6125
203-758-8272

Fax: 203-758-8271

E-Mail: sales@pic-design.com

Web: www.pic-design.com

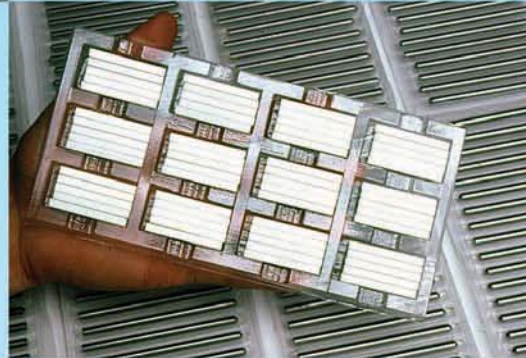

PIC Design's catalog is available on the web at www.pic-design.com not only as presented in this catalog, but also in a complete interactive version. It contains calculations, design selections (wizards), pull downs and CAD drawings. Also available is the ability to get a price, inventory status/lead time and place your order.

Get The Same PIC DESIGN High Quality
For Your Volume & Build-To-Print
Parts And Assemblies!

See Last Page For Details



Call **PIC**
Phone: 800-243-6125
203-758-8272
Fax: 203-758-8271
E-Mail: sales@pic-design.com
Web: www.pic-design.com



Bulk Rate
U.S. Postage
PAID
Permit #14
Middlebury, CT
06762

PIC[®]
DESIGN

Precision Industrial Components LLC
86 Benson Road, P.O. Box 1004
Middlebury, CT 06762-1004



For fifty years PIC Design has been the gold standard for manufacturers of precision industrial components. Our quality service and integrity are appreciated by our vast number of repeat customers and envied by our competitors. If you are new to PIC Design, we look forward to working with you on your next requirement as well as through the next 50 years.



PIC Design is located in the Naugatuck Valley of Connecticut – famous as the precision machining center of the country. Our size allows us to respond quickly with the solution to most any problem. Our location provides a wealth of backup skills and services unique to this area. As the pioneer and leader in the field of precision industrial component catalog sales, PIC has always maintained a very high standard of quality and service commanding good will, respect and loyalty of over 20,000 active customers.

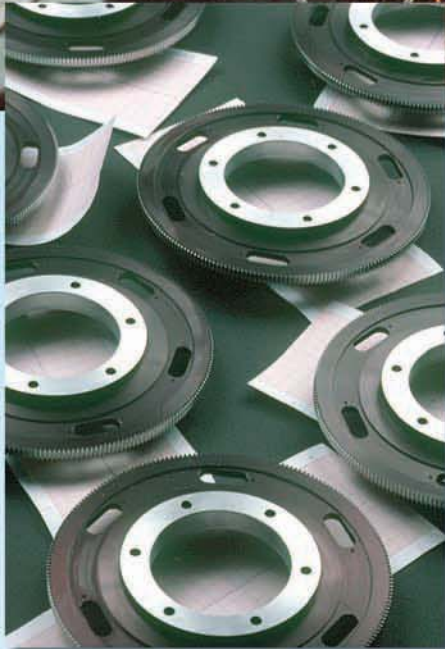
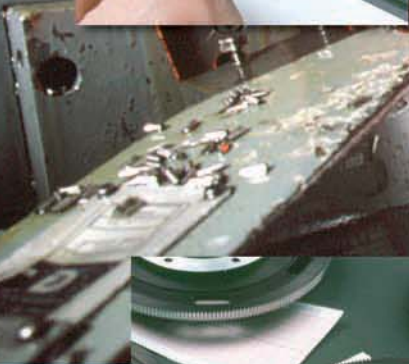

Let's discuss your volume parts or sub-assembly requirements.

Call PIC's headquarters between 8 A.M. and 5 P.M. Eastern Time.

Phone: 800-243-6125
203-758-8272

Fax: 203-758-8271

E-Mail: sales@pic-design.com

Web: www.pic-design.com

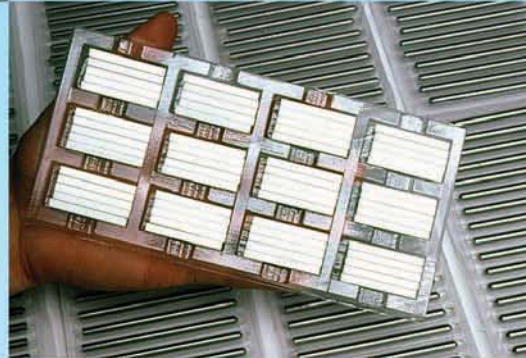

PIC Design's catalog is available on the web at www.pic-design.com not only as presented in this catalog, but also in a complete interactive version. It contains calculations, design selections (wizards), pull downs and CAD drawings. Also available is the ability to get a price, inventory status/lead time and place your order.

Get The Same PIC DESIGN High Quality
For Your Volume & Build-To-Print
Parts And Assemblies!

See Last Page For Details



Call **PIC**

Phone: 800-243-6125
203-758-8272

Fax: 203-758-8271

E-Mail: sales@pic-design.com

Web: www.pic-design.com



Bulk Rate
U.S. Postage
PAID
Permit #14
Middlebury, CT
06762

PIC[®]
DESIGN

Precision Industrial Components LLC
86 Benson Road, P.O. Box 1004
Middlebury, CT 06762-1004