

RBC Aerospace Applications

Titanium Bearings

Originally designed and qualified in the late 1980s, RBC Aerospace Bearings offers a variety of **titanium plain spherical bearings, rod end bearings, and journal bearings** for applications requiring maximum strength, light weight, and reduced maintenance.

Featured in applications throughout the aerospace and defense industry, these bearings are proven for use in engine hangers, trunnion bearings, helicopter rotor head bearings, landing gear bearings, and a variety of additional custom-engineered solutions.

Titanium has excellent inherent corrosion resistance due to a thin oxide surface film, eliminating the need for cadmium plating; unlike other materials such as 4340 steel. This results in a much “greener” product. Titanium is especially resistant to salt solutions, making it an ideal material for sea water applications.

RBC Aerospace Bearings offers a variety of titanium plain spherical bearings, rod end bearings, and journal bearings.

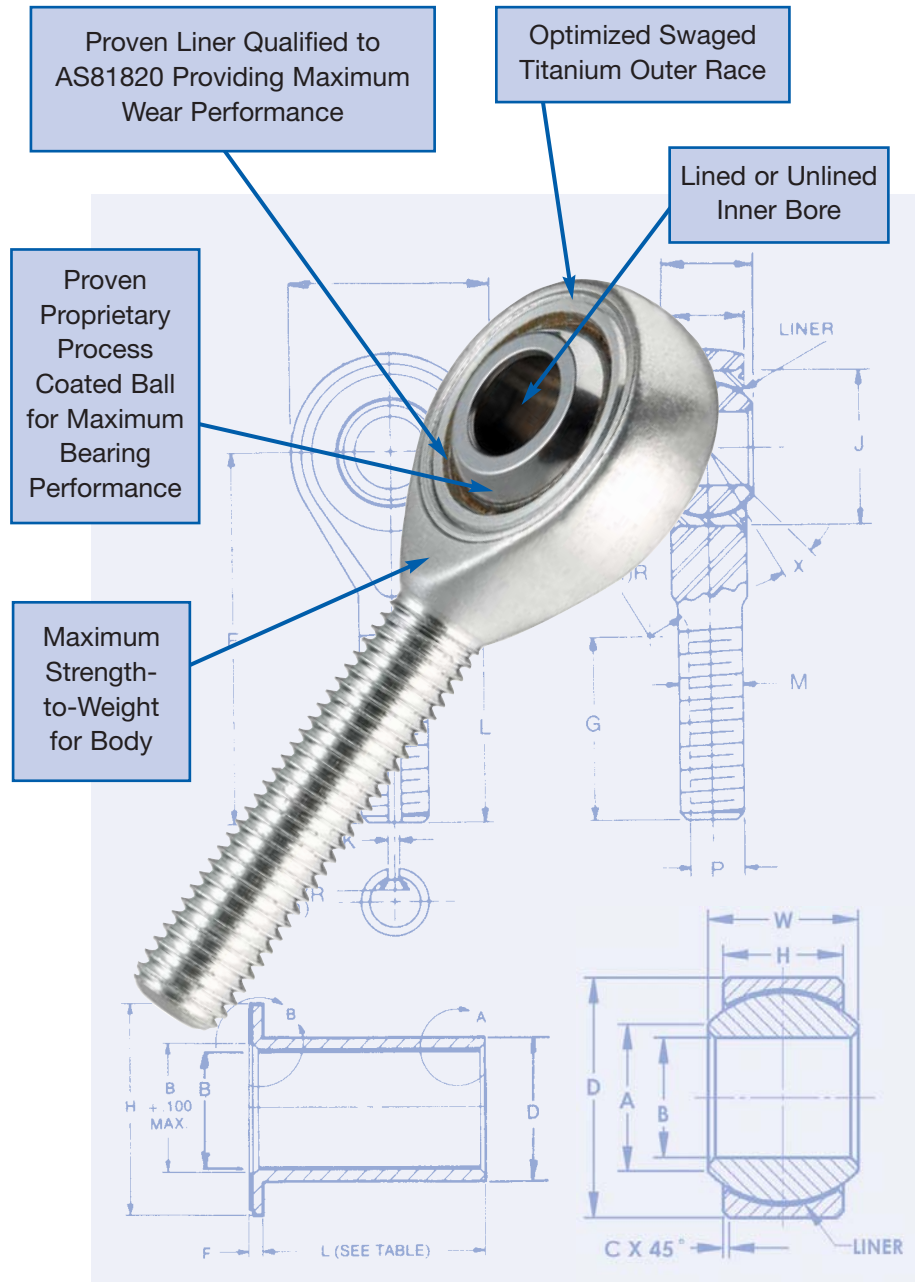

Current Production Applications

- Engine Hangers
- Landing Gear Bearings
- Trunnion Bearings
- Flight Control Bearings
- Helicopter Rotor Head Bearings
- Reverse Thrust Mounts
- Duct Support Bearings
- Gear Box Support Bearings

RBC Aerospace Applications

Titanium Bearings

Highest Strength-to-Weight Ratio

Titanium bearings provide excellent strength-to-weight properties for applications that require a strong material without weight penalty.

Superior Corrosion Resistance

Titanium has excellent inherent corrosion resistance due to a thin oxide surface film, eliminating the need for cadmium plating; unlike other materials such as 4340 steel. This results in a much “greener” product. Titanium is especially resistant to salt solutions making it an ideal material for sea water applications.

Temperature Capability

Titanium bearings are recommended for a wider range of operating temperatures. Useful temperature range is -320°F to +750°F. Ti-6Al-4V alloy will retain above 60% of its tensile properties at 750°F.

Proven Wear Performance

RBC Aerospace Bearings provides a variety of self-lubricated liner materials depending upon the application. Extensive material testing has developed a proprietary hard coat for the titanium ball. Wear characteristics are equivalent to the standard 440C CRES ball material.

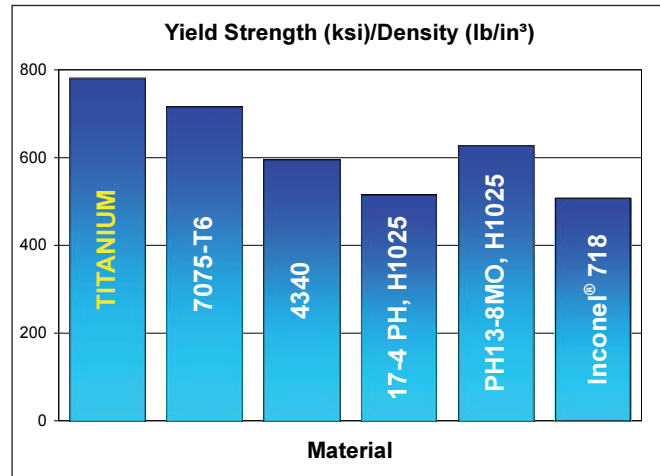

Inconel® is a registered trademark of Special Metals Corp

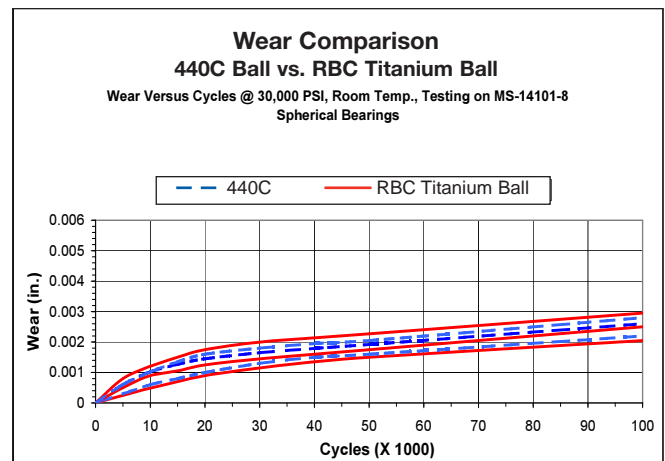
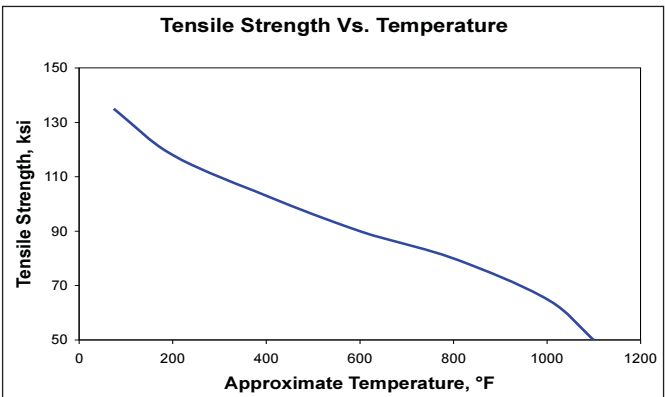

This document contains a general overview of the products and features described herein. It is solely for informational purposes, does not represent a warranty of the information contained herein, and is not to be construed as an offer to sell or a solicitation to buy. Contact RBC Bearings Incorporated for detailed information suitable to your specific applications. RBC Bearings Incorporated reserves the right to modify its products and related product information at any time without prior notice.

Some of the products listed herein may be covered by one or more issued and pending U.S. or foreign patents. Contact RBC Bearings for product specific information.

© 2007 RBC Bearings Incorporated

RBC 4/07